

This obsolete manual file is provided as a courtesy to you by Ten-Tec, Inc.

Ten-Tec's service department can repair and service virtually everything we have built going back to our first transceivers in the late 1960's. It is our ability to continue offering service on these rigs that has led to their re-sale value remaining high and has made a major contribution to our legendary service reputation.

Printed and bound copies of all manuals are available for purchase through our service department if you would prefer not to use this copy as your transceiver manual.

We can repair or service your Ten-Tec equipment at our facility in Sevierville, TN. We also offer support via telephone for all products via during usual business hours of 8 a.m. to 5 p.m. USA Eastern time, Monday through Friday. We have a large supply of parts for obsolete products. Repairing a transceiver or amplifier yourself? Contact us for parts pricing information.

**Service department direct line: (865) 428-0364
Ten-Tec office line: (865) 453-7172
Service department email: service@tentec.com
Address: 1185 Dolly Parton Parkway, Sevierville, TN 37862 USA**

We have found it is most effective for us to help you troubleshoot or repair equipment with a consultation via telephone rather than by email.

Suggested contact methods are:

**Troubleshooting or repairing equipment – call (865) 428-0364
Other inquiries – call (865) 428-0364 or email service@tentec.com**

THANK YOU AND 73 FROM ALL OF US AT TEN-TEC

TEN-TEC

**OWNER'S
MANUAL**

Corair



CONTENTS

SECTION		PAGE
I	INTRODUCTION	1- 1
	CONDENSED OPERATING INSTRUCTIONS	1- 1
	SPECIFICATIONS	1- 2
II	DETAILED OPERATING INSTRUCTIONS	2- 1
	Rear Panel Connections	2- 1
	Front Panel Controls	2- 3
	Operating Hints	2- 7
	An Important Message	2- 8
III	ALIGNMENT AND SERVICE	3- 1
	Internal Adjustments	3- 1
	Disassembly	3- 1
	Pilot Lamp Replacement	3- 1
	Fuse Replacement	3- 2
	Rotary Switch Care	3- 2
	Semiconductor Identifications	3- 3
	SIGNAL BLOCK DIAGRAM	3- 4
	MAIN CHASSIS WIRING	3- 5
	TOP VIEW	3- 6
	BOTTOM VIEW	3- 6
	PTO 81038	3- 7
	OSCILLATOR MIXER 80975	3- 8
	RF MIXER 80987	3-10
	NOISE BLANKER 80977	3-11
	PBT, PASS BAND TUNING 80979	3-13
	IF-AF 80984	3-15
	VOX-PROCESSOR 80981	3-18
	DOUBLE SIDEBAND GENERATOR 80980	3-20
	LOW LEVEL DRIVER 81037	3-21
	FINAL AMPLIFIER 80565	3-23
	BANDPASS FILTER 80976	3-24
	LOWPASS FILTER 80969	3-25
	SWR BOARD 80970	3-25
	DIGITAL READOUT 80973-80974-80547	3-27
	CONTROL BOARD 80978	3-29
	LED DISPLAY 80983	3-31
	SWITCH BOARDS 80971-80972-80982	3-31
	PARTS LISTS	3-32



SECTION I INTRODUCTION

Carefully remove your Model 560 CORSAIR from the packing carton and examine it for signs of shipping damage. Should any shipping damage be apparent, notify the delivering carrier or dealer immediately, stating the full extent of the damage. It is recommended that you keep the shipping cartons. In the event that storage, moving, or reshipment becomes necessary, they come in handy. An accessory packet, warranty card and manual are packed with the CORSAIR. Make sure that you have not overlooked anything.

The CORSAIR is a medium power transceiver employing the latest techniques in solid state technology. It features digital frequency readout which inherently contains a crystal oscillator for accuracy.

As shipped from the factory, the CORSAIR contains all necessary crystals for transceiver operation in the 160, 80, 40, 30, 20, 17, 15, 12 and 10 meter bands.

The CORSAIR is extremely versatile. Although essentially a fixed station, it is equally at home when used mobile or portable. It operates from 12-14 volts dc or from 115/230 volts ac with an external power supply.

As you become familiar with the operation of your CORSAIR, you will value the built-in operating conveniences more and more. Broad band circuitry eliminates tuneup. The normal sideband is selected, whether it be upper or lower, according to the band in use. Indicator light emitting diodes (LEDs) are provided for the

RECEIVE-TRANSCIVE SWITCH - For normal transceiver operation, position this switch in the TRANSCEIVE position. If an external amplifier or a separate receiving antenna is to be used, refer to the detailed instructions in SECTION II. (Use a small probe to actuate switch. Raised bezel prevents accidental throwing of switch.)

KEY - For cw operation, connect a straight key, bug, or electronic keyer such as Model 645 ULTRAMATIC to this jack. When using other electronic keyers, they should be configured for positive keying - not "grid block" or negative.

FRONT PANEL CONTROLS

INITIAL RECEIVER CONTROL SETTINGS

- 1.) Select desired band and frequency.
- 2.) Rotate RF control fully clockwise and push knob in.
- 3.) Advance AF control to suitable audio level.
- 4.) Rotate NOTCH control fully clockwise.
- 5.) Set XTAL switch to position 3.
- 6.) Set MODE switch to CW or SB-N.

DIMENSIONS: HWD 5- $\frac{1}{2}$ " x 15" x 14" (13 x 38 x 36 cm), bail retracted.

NET WEIGHT: 14 lbs (6.4 kg).

RECEIVER

SENSITIVITY: 0.25 μ V for 10 dB S+N/N, all bands. 0.8 μ V typical with RF amplifier off.

SELECTIVITY: 12-pole crystal ladder filtering. 2.4 kHz bandwidth, 1.7 to 1 shape factor at 6/60 dB. Three position switch selects standard ssb filter, optional 1.8 kHz ssb filter, 500 Hz cw filter, or 250 Hz cw filter.

NOTCH FILTER: Greater than 50 dB notch tunable between 200 Hz and 3.5 kHz.

CW SPOT: With 750 Hz reference tone.

I-F FREQUENCIES: 9 MHz and 6.3 MHz.

ANTENNA INPUT: Low impedance, unbalanced.

AUDIO OUTPUT: 1 watt @ 8 ohms with less than 2% distortion. Built-in speaker.

SPURIOUS RESPONSES: All below equivalent 10 dB S+N/N signal except 1.838 MHz (less than 15 dB S+N/N), 21.300 MHz (less than 20 dB S-N/N), and 28.980 MHz (which can be eliminated by using low end of 29.0-29.5 MHz band segment).

NOISE BLANKER: Built-in, adjustable blanking threshold.

I-F REJECTION: Greater than 60 dB.

S-METER: Automatically switched on when receiving. Calibrated to 50 μ V at S9, \pm 3 dB.

DYNAMIC RANGE: 90 dB, typical.

OFFSET TUNING: Dual range, MAX \pm 4 kHz; MIN \pm 500 Hz, typical.

TRANSMITTER

DC POWER INPUT: Maximum 200 watts @ 14 V dc cw and ssb. 100% duty cycle for up to 20 minutes.

RF POWER OUTPUT: 85-100 watts, typical.

OUTPUT IMPEDANCE: 50 ohms, unbalanced.

MICROPHONE INPUT: High impedance. Accepts high or low impedance microphones with 5 mV output. Polarizing voltage available for electrets.

T/R SWITCHING: VOX or PTT on ssb. Instant break-in or semi-break-in on cw.

CW SIDETONE: Internally generated. Adjustable tone and volume independent of af gain control. Operates only in cw mode.

SSB GENERATION: 9 MHz, 4-pole crystal ladder filter. Balanced modulator.

CARRIER SUPPRESSION: 60 dB typical.

UNWANTED SIDEBAND SUPPRESSION: 45 dB typical at 1.5 kHz tone.

SPURIOUS OUTPUT: Better than -45 dB relative to full output.

METER: Forward power, collector current, SWR, processing level. Selectible 4 position switch.

CW OFFSET: 750 Hz, automatic.

ALC CONTROL: Front panel adjustable. 30 to 100 Watts output, LED indicator.

FRONT PANEL CONNECTIONS AND CONTROLS

PBT; OFFSET; AF-RF AMP; RF-POWER; NOTCH; DRIVE; Bandswitch; Main Tuning Knob; MODE; METER switch; VOX GAIN; VOX DELAY; PROCESS level; N.B. LEVEL; ALC threshold; QSK/VOX

SECTION II
DETAILED OPERATING INSTRUCTIONS
REAR PANEL CONNECTIONS



HF TRANSCEIVER
MODEL 5900R5A1R

AUDIO IN
EXT. T/R

GROUND STRAP

To reduce the possibility of stray rf pickup on interconnecting cables which may cause parasitic oscillations, all station equipment should be well grounded to earth. It is also important to strap all equipment chassis together with short, heavy leads, preferably with braid. The strap between the power supply and the transceiver also serves to reduce voltage drop on the negative 12 volt lead caused by resistance in the wire and connector contacts. In mobile installations, connect a ground strap between the rear panel ground lug and the automobile chassis.

ANTENNA

Any antenna presenting 50 to 75 ohms impedance will load satisfactorily. Random length antennas and open wire feed systems will require a matching system such as Model 227 Antenna Tuner. Most popular mobile antennas will operate at their resonant frequency without special matching. When they are used as portable antennas, a good ground system or counterpoise should be provided. The CORSAIR is designed for use with an unbalanced feed system. Coaxial shield is connected to the shell and the center conductor to the pin of the PL-259 connector.

EXT T/R

This jack is intended to actuate a high power linear amplifier. It is derived from a set of normally open contacts on the auxiliary relay located on the Control Board. One side of this switch is also at ground potential and therefore should not be used to switch the 115/230 volt line. When operating cw, a drop-out delay is incorporated in the relay circuit and is adjustable with a thumb potentiometer located on the CONTROL BOARD. When operating sfb, this drop out delay is switched out of the circuit. Since this relay does not control any of the internal

RECEIVE ANTENNA

This jack provides an antenna connection directly to the receiver input at all times by placing the RECEIVE-TRANSCIVE switch to the RECEIVE position. This also allows for the use of an external receiver when the switch on the rear panel is placed in the TRANSCEIVE position and the external receive antenna input is connected to the jack.

RECEIVE-TRANSCIVE SWITCH

This switch, in the RECEIVE position, connects the receiver antenna terminal to the RECEIVE ANTENNA jack directly. It is used when an instant break-in linear or separate receiving antenna is used. In the TRANSCEIVE position, the receiver input is connected to the ANTENNA socket for normal transceiver operation.

VFO IN-OUT

These jacks provide means to switch the internal PTO signal on and off when using Model 263 Remote VFO accessory. As shipped from the factory, these two jacks are connected externally with a U shaped jumper pin.

PTT

This jack is in parallel with the push-to-talk line on the microphone jack. It may be used as an external transmit/receive station switch and is operable only in the ssb mode.

EXTERNAL SPEAKER

Phone jack, for connecting external speaker. Using this jack disconnects the internal speaker.

FRONT PANEL CONTROLS

METER SWITCH

In receive mode, the meter will automatically read S units when the METER switch is in any position except IC. When transmitting the meter indicates the following:

IC position measures the current drawn by the final amplifier module. Use the scale marked 0 to 20 amperes.

SWR position provides a reading of power reflected from the antenna. When the forward power is 100 watts, the SWR can be read from the scale marked SWR.

OFFSET TUNING

The OFFSET control allows independent control of the receive or transmit frequency, through two selectable excursion ranges, as determined by the position of the OFFSET SELECT switches. Clockwise rotation from the center position increases the frequency, counterclockwise rotation decreases the frequency.

Offset tuning is advantageous when several stations are being worked in a roundtable, and all are not exactly on the same frequency. The received stations can be "zeroed in" with the OFFSET control without upsetting your transmit frequency. This is termed RECEIVE offset tuning and is engaged by placing the OFFSET SELECT switch in the RX position. Transmit offset is useful when a station calling CQ says "listening 2 kHz up". Without changing the VFO, select RX offset, tune OFFSET control 2 kHz higher than select TX offset. The original frequency will be returned and the transmit frequency will be 2 kHz higher than that indicated during receive. Transceiver offset, TRX on the OFFSET SELECT switch, permits excursions away from a set frequency. For instance, moving away from a net frequency for traffic to a specific station.

The offset tuning has two selectable range choices, MIN and MAX, plus an OFF position. In the MAX position, excursion is about ± 4 kHz. In the MIN position, excursion is about ± 500 Hz, for fine tuning. No matter what position the OFFSET control is in or what type of offset is selected, moving the selector switch to the OFF position will defeat all OFFSET functions.

The OFFSET LED indicator lights whenever the offset circuitry is on. For instance, if TX offset is selected the OFFSET LED will be on only during transmit. Also, the digital frequency display will show the actual frequency including the offset when in use.

NOTCH

The NOTCH filter control adjusts the frequency of the audio notch across the passband. The NOTCH depth is at least 50 dB and will reduce carrier interference by this amount or more since the notch is inside the AGC loop. The notch circuit is effectively removed by turning the control fully cw.

VOX-QSK SWITCH

This switch selects either the internal VOX (voice operated transmitter) or manual PTT (push-to-talk) circuitry. Also controlled is the recovery speed of the receiver. In the VOX position, the VOX circuit

PROCESS

The PROCESS control/switch activates the speech processor and determines the processing level. The processor increases the average speech power and allows a greater range of voice levels to attain peak ALC level. When the processor is on, the PROCESS LED indicator will light and the process level will be displayed on the

meter when the METER switch is in the process position. Proper level is indicated with a half scale reading on the meter. The level of processing will affect the DRIVE to some extent. To set the processor, turn it off and while speaking into the mic in a normal voice, advance the drive until the ALC LED lights on voice peaks. Turn the PROCESS control on and advance it until the ALC LED again lights on voice peaks. This should be approximately at mid-rotation of the control. More processing can be had by further clockwise rotation but the DRIVE control must be reduced to keep the ALC action constant. Severe voice distortion, objectionable background noise and transmitted splatter will occur if the DRIVE control is not kept just to the point where the ALC LED lights on voice peaks.

NOISE BLANKER LEVEL

This control sets the blanking threshold. When fully CCW, the blanker is essentially off. CW rotation increases the blanker sensitivity. This permits fine adjustment of blanking and prevents the blanker from overloading.

SPOT

When this pushbutton is pressed, the offset circuit is placed in its selected transmit condition, i.e., if receive offset is being used, pressing the SPOT button will turn it off. Also, a 750 Hz audio tone will be generated which can be beat against the desired cw signal. The tuning is then adjusted so the signal is the same as the tone. This will place the transmitted signal exactly on top of the desired signal, zero beat.

DRIVE

Both microphone gain and cw level are adjusted with the DRIVE control. For ssb, advance control under normal speech operation until ALC indicator lights on voice peaks. For cw, advance the control until ALC is

WWV

Broadcasts of WWV may be received on 10 MHz for checking the accuracy of the time base oscillator in the CORSAIR. In addition, WWV broadcasts propagation reports and time verification.

- 1.) Set BAND switch to 10.0 MHz.
- 2.) Rotate Main Tuning Knob so that frequency readout is 10.0000 MHz.
- 3.) Set XTAL switch to 2.4.
- 4.) Set MODE switch to SB-N.
- 5.) Zero beat the WWV signal. The digital readout should read 10.0000. If it does not, the time base oscillator may be adjusted as outlined in SECTION II.

MOBILE OPERATION

The CORSAIR is ideally suited for mobile operation in a car, boat, plane, or other vehicle. It operates directly from a 12 volt battery source and is self-contained except for key, microphone, and antenna. When operating from any power source other than a TEN-TEC power supply, the protective circuitry for the final amplifier is not present. Model 1140 Circuit Breaker is required in series with the +12 volt supply line. The Model 1140 Circuit Breaker will function as both an external on-off switch and an over-current protection device for the final amplifier.

The SWR meter is especially useful in setting mobile whip antenna lengths to the operating frequency.

When using an alternator charged battery, start and stop the vehicle's engine with the CORSAIR turned off. This prevents any high voltage transients, caused by momentarily open regulator contacts, from being applied to the transceiver circuits.

FIXED STATIONS

The CORSAIR, with conventional antennas, will perform with distinction in any ham shack. With a linear, power can be increased to any value desired up to the legal limit. For an emergency or stand-by station it will operate for long periods of time with a 12 volt automobile storage battery. In most cases

ating time can be achieved by setting the ALC control down from its maximum position.

BAIL STAND

The movable bail is primarily intended to raise the front panel to a convenient slanting position. In this position, the speaker output is effectively radiated forward due to the "V" formed by the transceiver bottom and the table top.

The bail may also be used as a carrying handle, but care should be taken to prevent deforming it.

OPERATING HINTS

- 7.) In the cw mode, the indicated frequency is the received frequency. To accurately read an incoming frequency, therefore, it is necessary to zero beat the signal, not peak it on the S Meter. This holds true no matter where the OFFSET control is set. When transmitting cw, the indicated frequency will be 750 Hz removed from the true transmitted frequency due to the BFO shift to bring the oscillator into the filter pass band. This shift will be in the same direction as the shift when working the SB-R mode, i.e. the indicated frequency will be higher than the transmitted frequency for the frequencies below 14 MHz, and lower for frequencies of 14 MHz and above. Due to the 750 Hz switch in frequency, every time the key is actuated when using the CORSAIR, an accurate transmitted frequency count cannot be made while sending code. To accurately determine the transmitted frequency, make the reading in LOCK or key-down condition and either add or subtract 750 Hz from the reading, depending on the band in use. (Example: To set up a transmitting frequency of 3.545 0 MHz, place MODE switch in LOCK position and adjust tuning for a reading of 3.545 7 MHz. For 14.062 0 MHz, set readout to 14.061 3 MHz.)
- 8.) Increasing the DRIVE setting over that required to just light ALC indicator will not result in any appreciable increase in power out. However, overdrive may increase ssb distortion products and destroy cw keying characteristics.
- 9.) In order to eliminate the internal, spurious 28.980 MHz signal found in the 28.5 to 29.0 band segment, change BAND switch to 29.0 to 29.5 band segment and tune below the lower edge of this band segment for 28.980 MHz.
- 10.) The VFO oscillator, like any LC tuned oscillator, may be adversely affected by ac magnetic fields cutting the coil turns. The oscillator output is frequency modulated at the line frequency, causing a "dirty" cw note and/or poor ssb quality in both transmit and receive modes. When installing the CORSAIR, locate any ac operated equipment which may generate magnetic fields, such as power supplies, electric clocks, keyers, rotator controls, and other station accessories as far as possible from it. Since the VFO is located front and center, the most common cause of FMing is from placing these accessories on top of the unit. A check of purity of a received cw signal should be made at the time of installation.
- 11.) Due to the possibility of high voltage transients being generated in the output rf amplifier during bandswitching, changing bands should not be done while transmitting power to the load. Either place the CORSAIR in the receive mode or be certain of a key-up condition in cw. **YOU RISK THE POSSIBILITY OF DESTROYING THE OUTPUT TRANSISTORS IF THIS PRECAUTION IS NOT OBSERVED.**
- 12.) Although improper antennas will not damage the final, we suggest an SWR below 2 to 1 be obtained for maxi-

- 9.) If the breaker repeatedly trips, it is an indication that the load is enough removed from optimum so as to cause high transistor dissipation.
- 10.) It is possible for the power supply regulator to drop out of regulation just prior to its tripping the breaker with low ac line voltages, (brown-outs or long ac power runs). Under these conditions, hum modulation will appear on the transmitted signal. With proper load and line voltage, the current drain will be considerably below the tripping point so no hum should appear on the carrier.

Technical Facts of Life

Although vacuum tubes and transistors both can be made to amplify rf power, there are some fundamental differences in how this is accomplished. A better understanding of what we can expect under various operating

Protective Circuitry and ALC - ALC serves three major functions. It assures the maximum power from the transmitter without careful adjustment of the input drive. It prevents the amplifier from being over-

SECTION III
ALIGNMENT AND SERVICE

GENERAL

This section covers maintenance and service of the CORSAIR transceiver. It includes information on trouble analysis, signal tracing and alignment procedures. Connector and transistor voltages are given for each unit. Readings should be within 15% of the listed value when measured with a dc voltmeter with at least 20,000 ohms-per-volt impedance. All readings are dc and positive with respect to the chassis ground unless stated otherwise. Adjust for occasional touch up to compensate for possible component aging, alignment normally will be necessary only if frequency determining components have been replaced.

When removing a particular assembly, note the orientation of the board in the chassis so that it can be replaced correctly. Many assemblies can be inadvertently inserted incorrectly if care is not taken. Figures 3-1

To replace the dial shift cipher, install the dial shift cipher...

SEMICONDUCTOR PIN IDENTIFICATION

PINS VIEWED FROM TOP
OF PC BOARD.

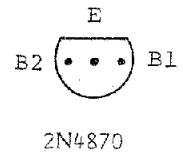
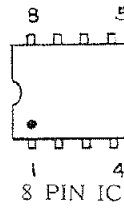
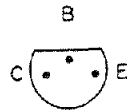
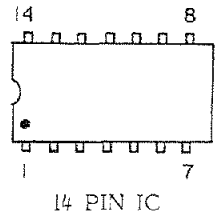
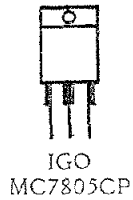
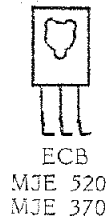
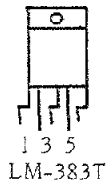
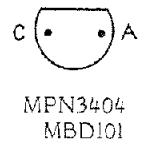
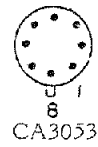
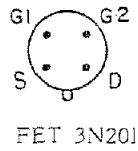
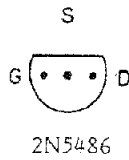
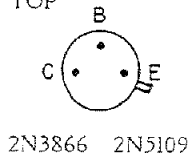

MODEL 560 CORSAIR MAIN SCHEMATIC

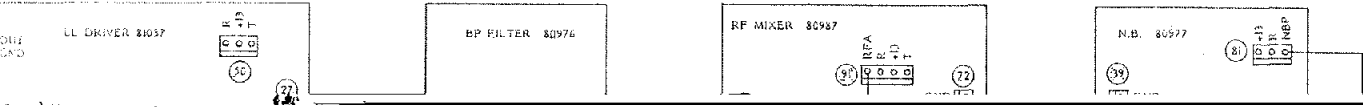



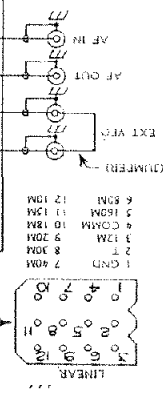
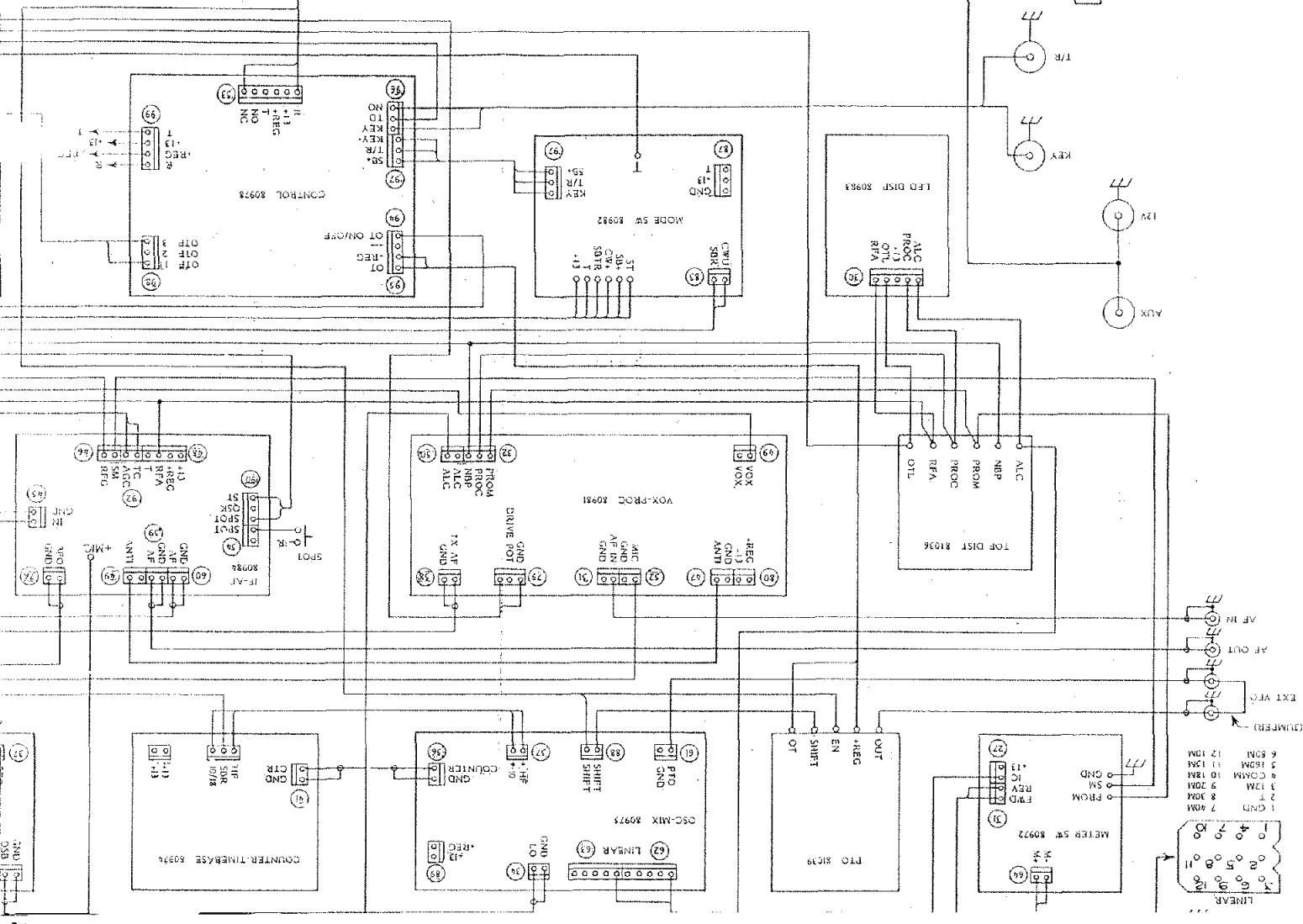
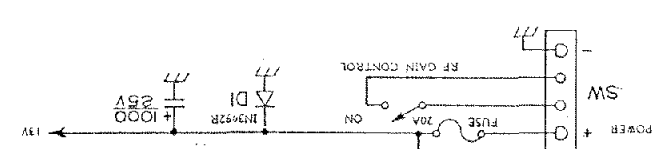
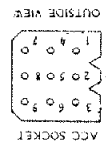
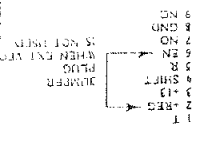

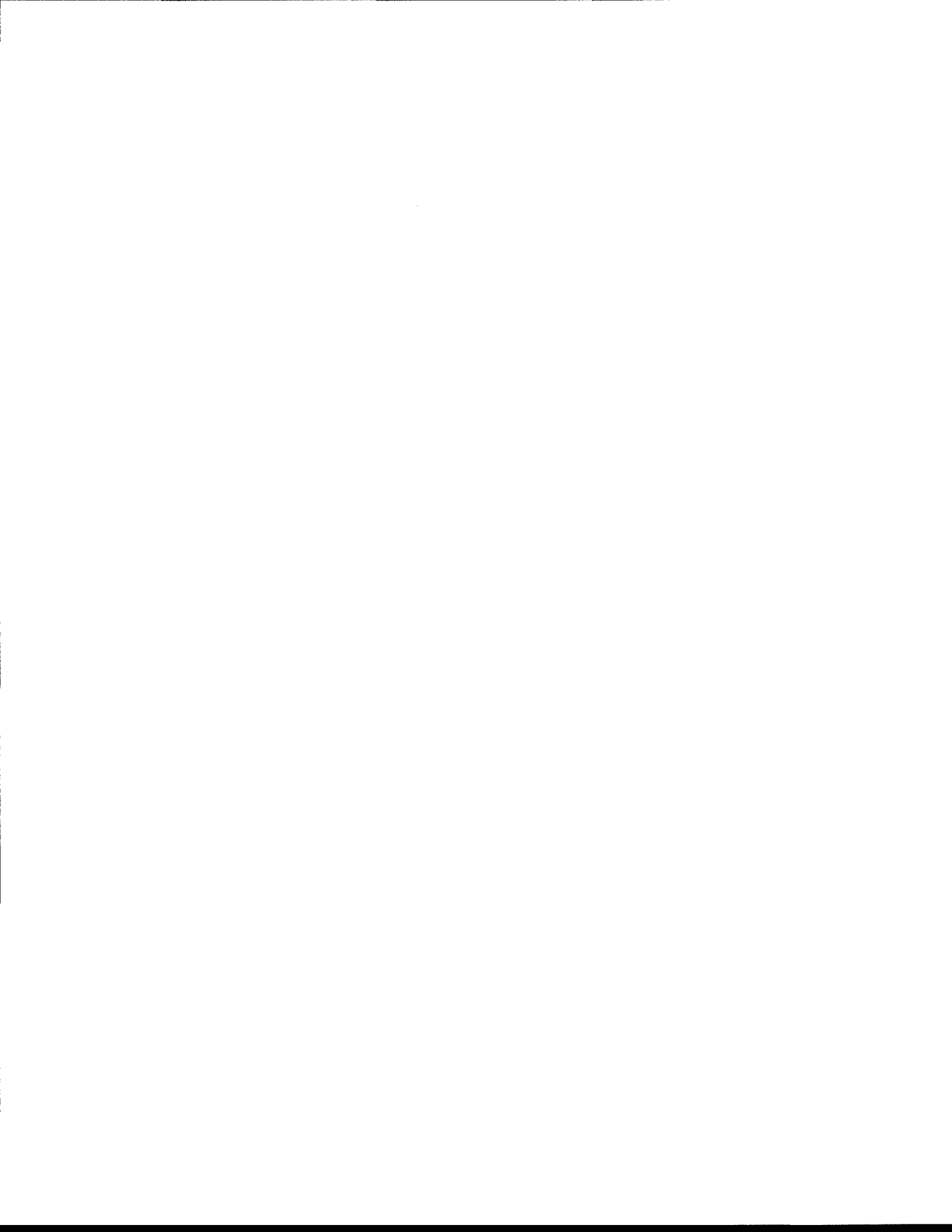

BLOCK DIAGRAM - MODEL 560

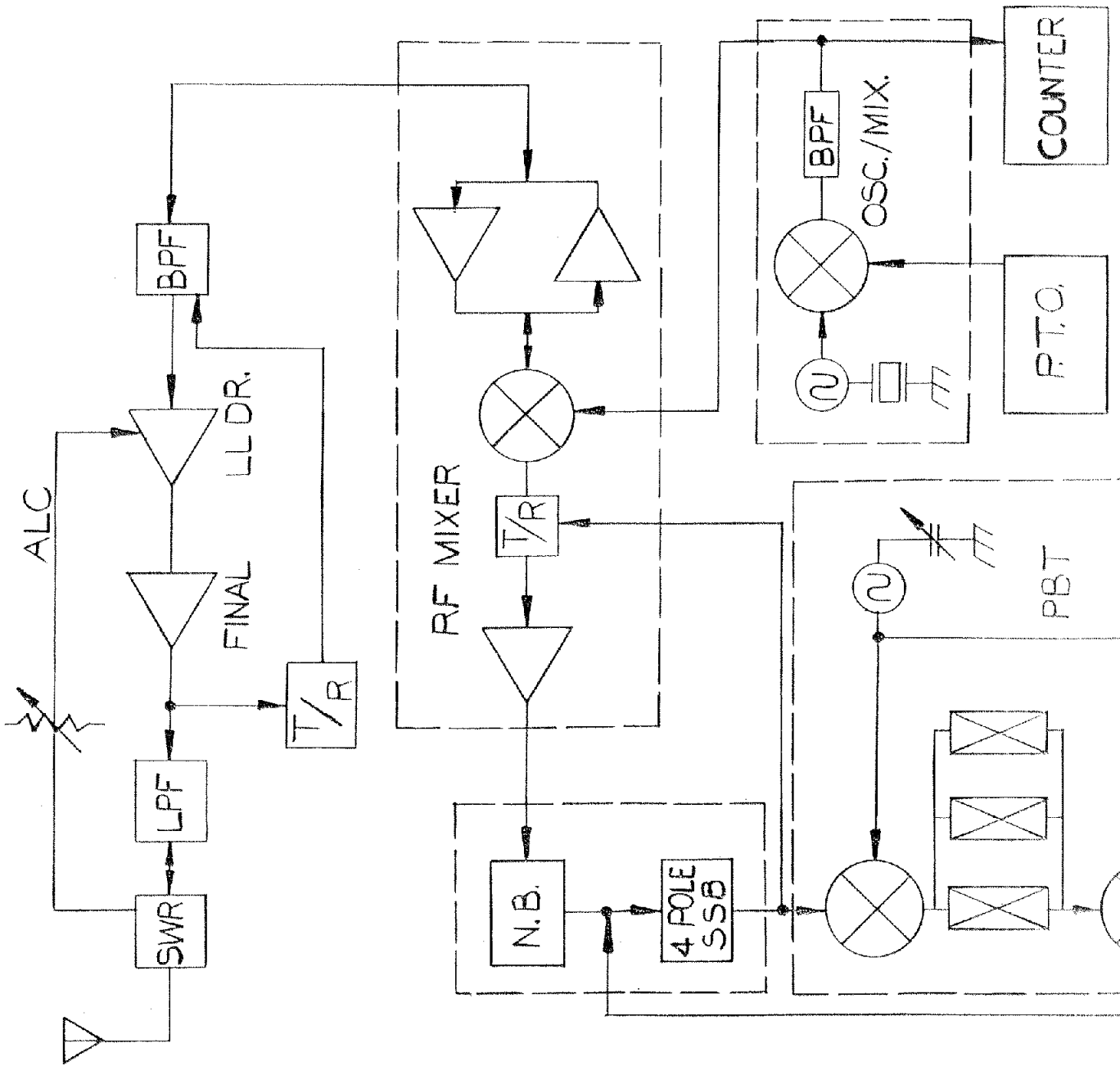

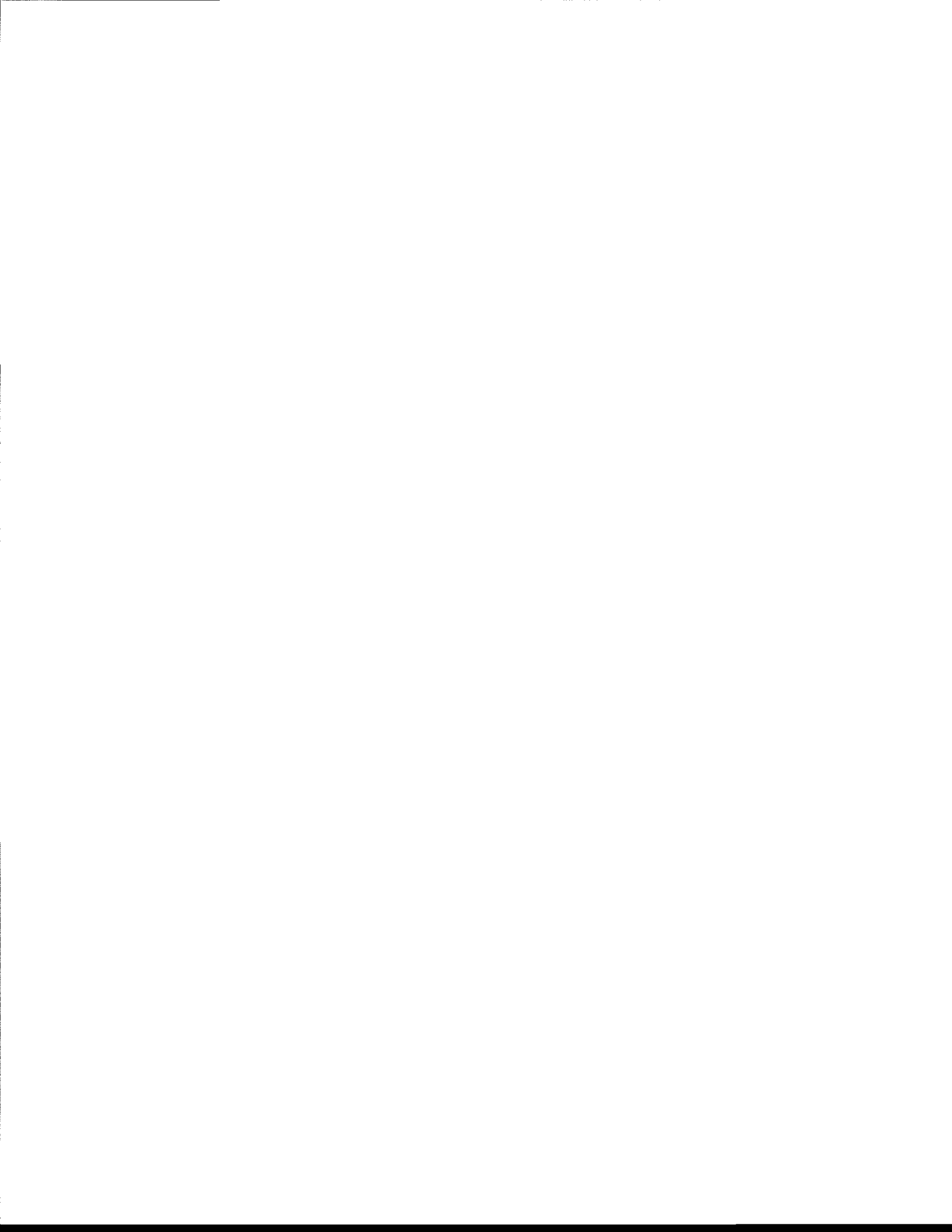

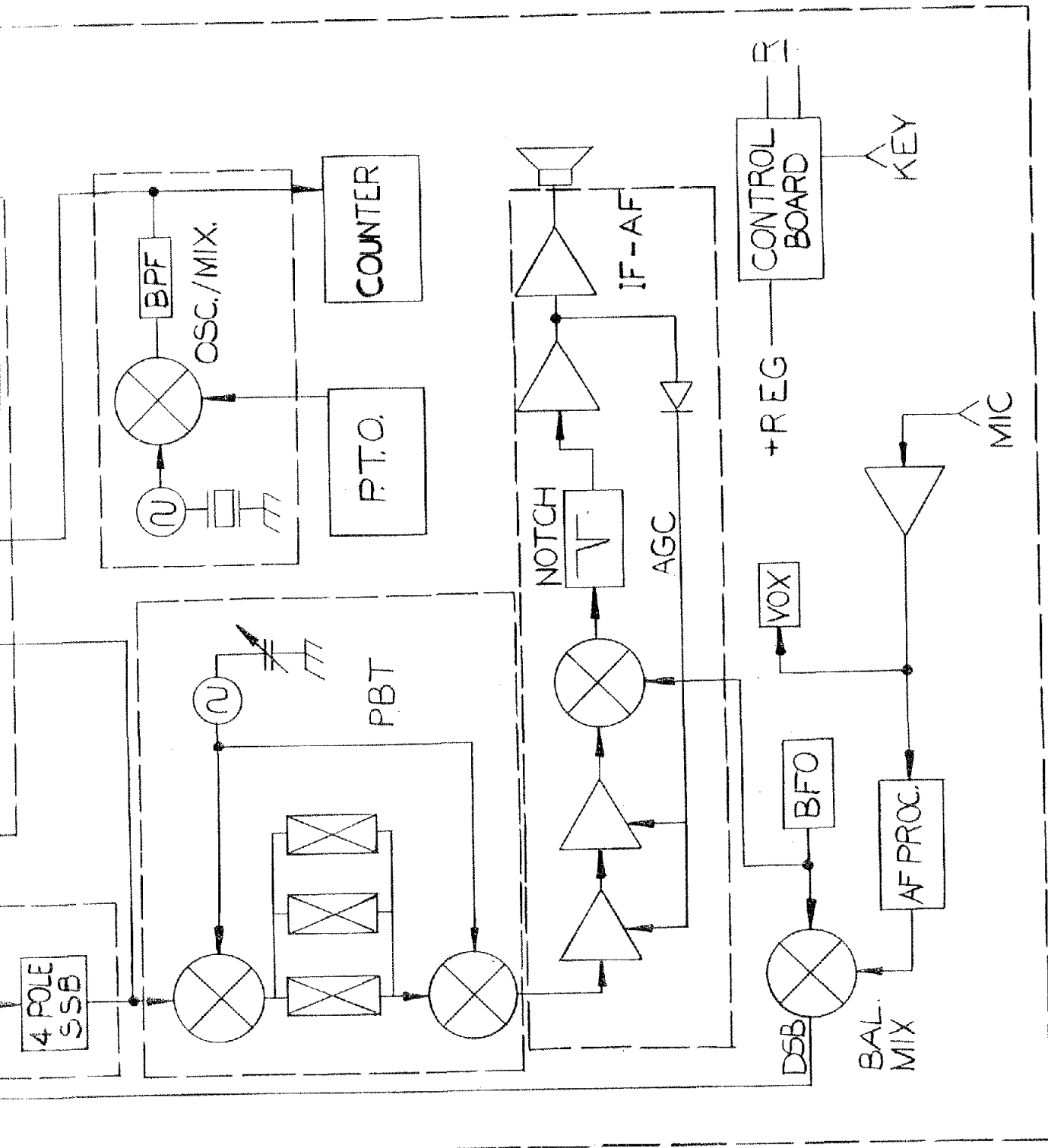



More than just a radio.



Ten-Tec is more than just a manufacturer of Amateur Radio equipment. Our legendary service department repairs almost everything we've ever built. Customer support representatives are active hams that can provide the advice you need to obtain the right equipment and set up your station the way it should be. No one in the industry matches our risk-free trial period for new equipment. When you buy Ten-Tec, you get our entire company in the box with your new radio. Ask a friend who owns "us". Proudly MADE IN USA!

1185 Dolly Parton Pkwy., Sevierville, TN 37862 Sales: 800-833-7373

We accept Visa, MC, American Express and Discover. Office (865) 453-7172. FAX (865) 428-4483.
Sales: Mon-Fri 8:00-5:30 (Eastern Time), sales@tentec.com. Service: Mon-Fri 8:00-5:00 (Eastern Time),
service@tentec.com, (865) 428-0364. Shipping is additional. TN residents add 9.5% sales tax

www.tentec.com

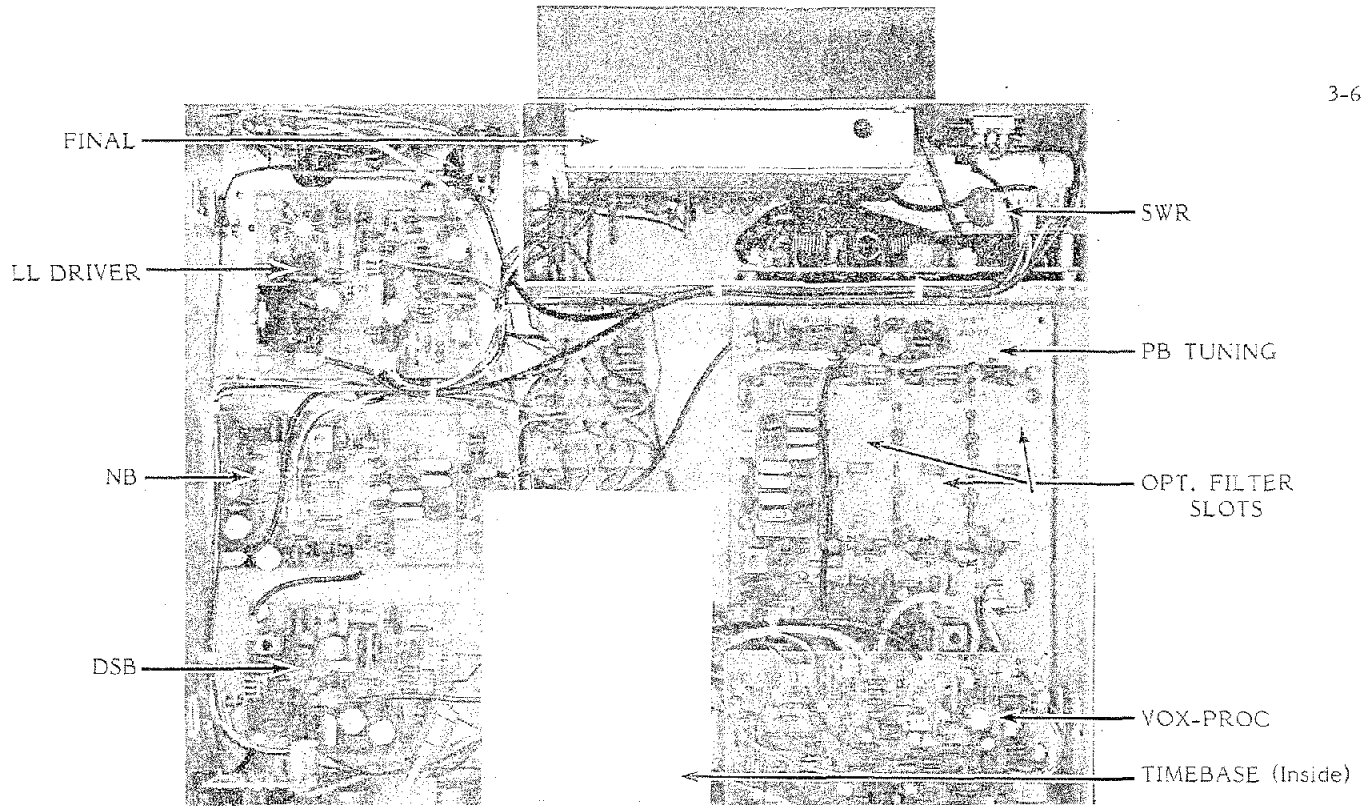

OSCILLATOR MIXER 80975

The circuits on this assembly produce proper injection frequencies for the transmitter and receiver circuits using a 9 MHz i-f system. This is accomplished by using the PTO 5.0 to 5.5 MHz master oscillator for all bands. The PTO is mixed in an integrated circuit double balanced mixer, UI, with signals from a crystal oscillator. Crystal frequencies are selected by the bandswitch. The 14 MHz band uses

mixer output on all but the 14 MHz band. They are overcoupled resonant circuits that are best aligned using a sweep oscillator system. Because they are wide band, realignment is seldom necessary except when a tuned circuit component is replaced.

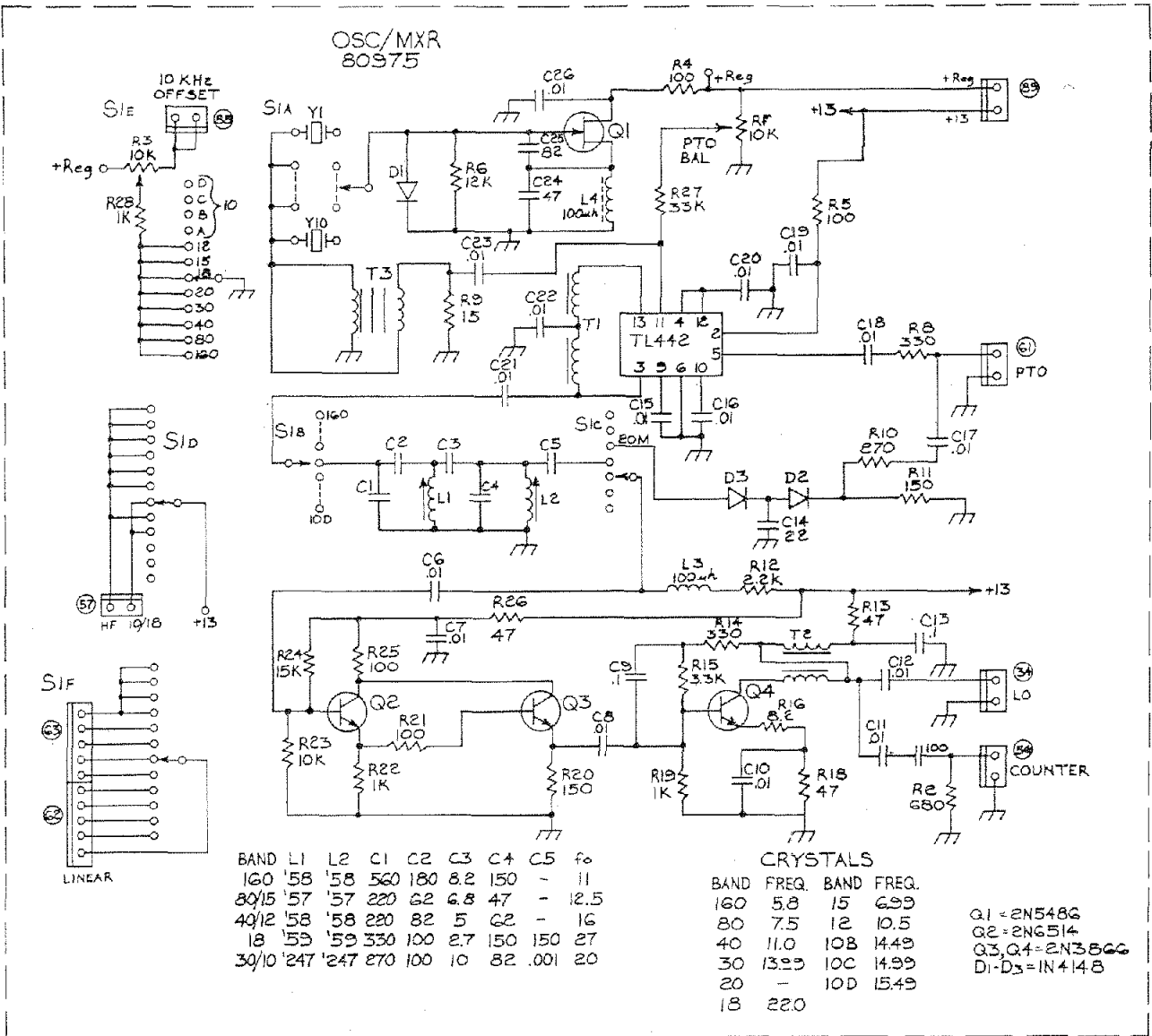

UI

PIN	VOLTAGE	
	RECEIVE	TRANSMIT
1	4.9	4.8
2	12.5	12.0
3	10.0	10.0
4	6.1	6.1
5	4.1	4.1
6	0	0
7	0	0
8	0	0
9	4.2	4.2
10	6.2	6.2
11	6.2	6.2
12	6.3	6.3
13	10.0	10.0
14	10.0	10.0

TRANSISTOR	COLLECTOR (drain)		BASE (gate)		EMITTER (source)	
	Receive	Transmit	Receive	Transmit	Receive	Transmit
Q1	7.4	7.4	.2	.2	0	0
Q2	9.2	9.2	4.4	4.4	4.1	4.1
Q3	9.2	9.2	3.9	3.8	3.2	3.2
Q4	11.75	11.75	2.2	2.2	1.5	1.5

RF MIXER 80987

This assembly contains the rf section of the receiver, its mixer and the first i-f amplifier, the transmitter mixer and its first low level amplifier stage. The selection of these amplifiers and the direction in which the signals flow is determined by the R and T voltages applied to the pin diodes. Amplifiers Q1 and Q3 are used on receive, and Q2 is used on transmit. Transistors Q4 and Q5 are switches which determine whether the rf amplifier or the attenuator is switched in on receive.

The mixer balance controls are adjusted as follows: 1.) Set the band switch to 21 MHz and dial to 21.200

2.) Center the balance control C1, C2 and R1. Terminate the antenna jack with a 50 ohm dummy load. 3.) Adjust in order R1, C1 and C2 to reduce the strength of any birdie that is received at this frequency.

Coil L1 is peaked on receive for maximum received signal.



RF MIXER 80987

TRANSISTOR	COLLECTOR		BASE		EMITTER	
	Receive	Transmit	Receive	Transmit	Receive	Transmit
Q1	5.8	0	1.0	0	.3	0
Q2	13.0	13.0	0	2.1	0	1.35
Q3	11.0	13.0	1.8	0	1.3	0
Q4						
Q5						

NOISE BLANKER 80977

The noise blanker is inserted in the receive i-f channel ahead of the high selectivity crystal filter. The signal is split into two paths, one for noise detection, the other for noise processing. Coils L2 and L3 form a bandpass filter which reject out of band signals and provide some signal delay for equalizing the noise detector delay characteristics. The filter feeds the signal input of a balanced noise gate formed by T1, D3, D4 and T2. The noise is detected and shaped by Q1 and U1 and transistor Q4 drives the blanker gate. Threshold action is obtained by varying the bias on transistor Q4. Transistors Q2 and Q3 comprise a direct coupled AGC amplifier whose control voltage is applied to Pin 5 and U1.

The bandpass filter can be aligned by tuning in the receive birdie at $27.980 \pm$ MHz. With the blanker control turned fully counterclockwise, peak C1 and C2 for maximum S-meter reading. With the blanker control turned fully clockwise, tune L1 for maximum AGC voltage at Pin 5 of U1.

This board also contains the first i-f crystal filter. As supplied by the factory, this filter is a 4 pole lattice

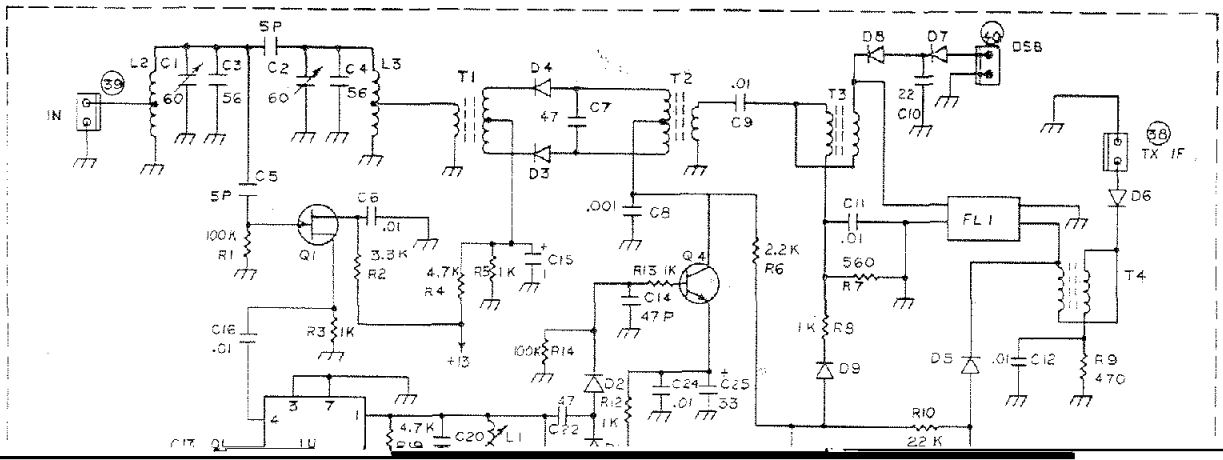

PBT, PASS BAND TUNING 80979

This board allows the operator to move one of the filters mounted on this board across the passband of the receiver. The filters are electronically switched. Each filter has an associated matching pad which keeps the attenuation through this board at a constant level. Coils L1, L2 and L3 are adjusted for maximum signal as monitored on the S-meter. Coil L4 determines the passband centering. To adjust this, turn the PBT control on the front panel to the center detent. While switching from sideband normal to sideband reverse, adjust coil L4 so the background hiss is approximately the same in either case. The adjustment of this coil is not critical.

When installing the Model 288, 1.8 kHz optional filter, be sure to remove the jumper on the top of the board. This jumper is located in the center of the 1.8 kHz socket.

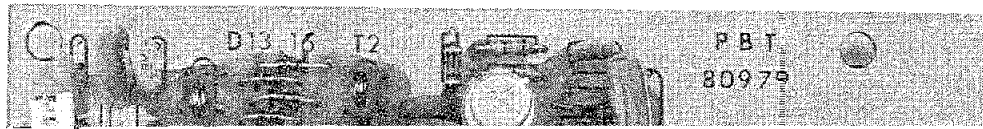

IF-AF BOARD 80984

This board contains only receive functions: The i-f amplifier Q1, Q2 and Q3, the product detector Q4, the notch filter U1, the audio pre-amp circuit U3, audio power amplifier U4, AGC detector U2, and the spot and sidetone circuits. There are three adjustments on this board. First, L1 and L2 are peaked for maximum receive signal on the S-meter. This should be done with as low an input signal level as possible. S-meter calibration is accomplished by adjusting R1 for an S9 reading on the meter when a 50 μ V, 14.0 MHz signal is applied to the antenna terminal with the RF AMP control on. With an audio frequency counter connected at the speaker, adjust R2 for 750 Hz indicated when the spot button is depressed. Adjust R3 for a comfortable listening level. R5 and R4 set the pitch and level of the sidetone on cw. These controls can be adjusted through the hole in the bottom cover.



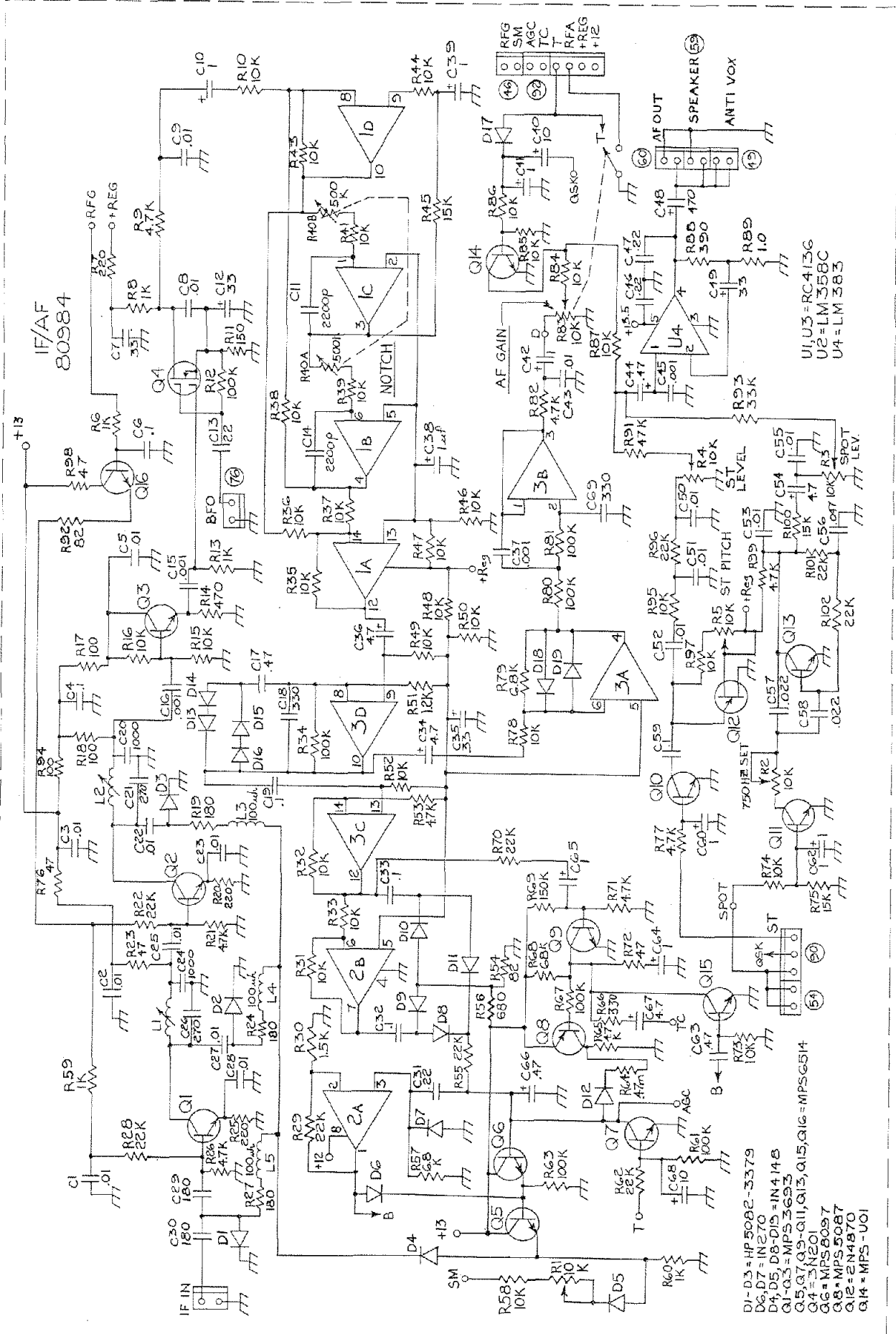

U1, U3 = RC413G
 U2 = LM 358C
 U4 = LM 385

- D1-D3 = HP 5082-3379
- D6, D7 = IN 270
- D4, D5, D8-D10 = IN 414B
- Q1-Q3 = MPS 3693
- Q5, Q7, Q9-Q11, Q13, Q15, Q16 = MPS 6514
- Q4 = 2N201
- Q6 = MPS 6057
- Q8 = MPS 5087
- Q12 = 2N4870
- Q14 = MPS-U01

U1

PIN	VOLTAGE	
	RECEIVE	TRANSMIT
1	3.8	3.8
2	3.7	3.7
3	3.8	3.8
4	3.8	3.8
5	3.7	3.7
6	3.8	3.8
7	0	0
8	3.8	3.8
9	3.5	3.5
10	3.8	3.8
11	7.5	7.5
12	3.8	3.8
13	3.7	3.7
14	3.8	3.8

U3

PIN	VOLTAGE	
	RECEIVE	TRANSMIT
1	3.8	3.8
2	2.0	2.0
3	3.8	3.8
4	3.8	3.8
5	3.7	3.7
6	3.8	3.8
7	0	0
8	3.8	3.8
9	3.4	3.4
10	7.5	7.5
11	3.8	3.8
12	3.8	3.8
13	3.7	3.7
14	3.8	3.8

U2

PIN	VOLTAGE	
	RECEIVE	TRANSMIT
1	0	0
2	0	0
3	0	0
4	0	0
5	3.7	3.7
6	3.8	3.8
7	3.8	3.8
8	7.5	7.5

U4

PIN	VOLTAGE	
	RECEIVE	TRANSMIT
1	.4	.4
2	.55	.55
3	0	0
4	6.5	6.5
5	13.0	13.0

TRANSISTOR	COLLECTOR		BASE		EMITTER	
	Receive	Transmit	Receive	Transmit	Receive	Transmit
Q1	12.0	12.5	1.7	0	1.0	0
Q2	10.5	11.5	1.7	0	1.0	0
Q3	10.0	10.5	4.5	4.8	3.9	4.2
Q5	13.0	13.0	.4	0	0	0
Q6	13.0	13.0	.65	0	.4	0
Q7	.65	0	0	.65	0	0
Q8	0	0	12.5	12.5	13.0	13.0
Q9	12.0	12.0	.35	.35	0	0
Q10	0	0	0	0	0	0
Q11	0	0	0	.25	0	0
Q13	1.0	1.0	.65	.65	0	0
Q14	0	0	0	.65	0	0
Q15	12.2	12.2	0	0	0	0
Q16	13.0	13.0	11.5	0	11.0	0

TRANSISTOR	SOURCE		DRAIN		GATE 1		GATE 2	
	Receive	Transmit	Receive	Transmit	Receive	Transmit	Receive	Transmit
Q4	.35	.35	4.7	4.7	.1	.1	0	0

TRANSISTOR	EMITTER		BASE 1		BASE 2	
	Receive	Transmit	Receive	Transmit	Receive	Transmit
Q12	1	1	0	0	1.8	1.8

VOX - PROCESSOR 80981

This board provides amplification of the microphone or patch-TU audio signal for the transmitter. U2A is the input buffer which drives both the VOX circuits (UI A,B,D) and the processor. The VOX produces a positive voltage signal from the microphone and a negative voltage signal from the ANTI VOX (speaker) input. Each is applied to the summing point and compared in UID with a fixed reference. When the reference is exceeded, the VOX is activated.

When adjusting the VOX, always start with the minimum VOX GAIN necessary to assure reliable switching, and use a moderate level of audio gain for the receiver. The ANTI VOX, R3, is set for a typical installation and should not need further adjustment. If speaker signals tripping the VOX occur too frequently, decrease the AF gain, move the microphone further away from the speaker, or decrease the VOX gain slightly. If this fails to produce proper VOX action, increase R3 slightly. Keep in mind that VOX GAIN, AF GAIN and ANTI all interact and changing one affects the others.

The speech processor is an AF peak clipper and compressor. This combination permits a higher processing level than either method by itself. The processor is switched in and out electronically by a two diode switch. Transistor Q3 is the shunt element of the compressor, and D11 and D12 are the clipping elements.

To adjust the internal processing level controls:

1. With the processor off and using a normal voice, adjust the DRIVE control for proper ALC action.
2. Turn the PROCESSOR on and advance it to center position.
3. Using the same voice, adjust R2 for equal ALC action.
4. Then adjust R1 for a reading in the center of the PROCESS area of the meter (meter switch in PROCESS position).



VOX-PROC 80981

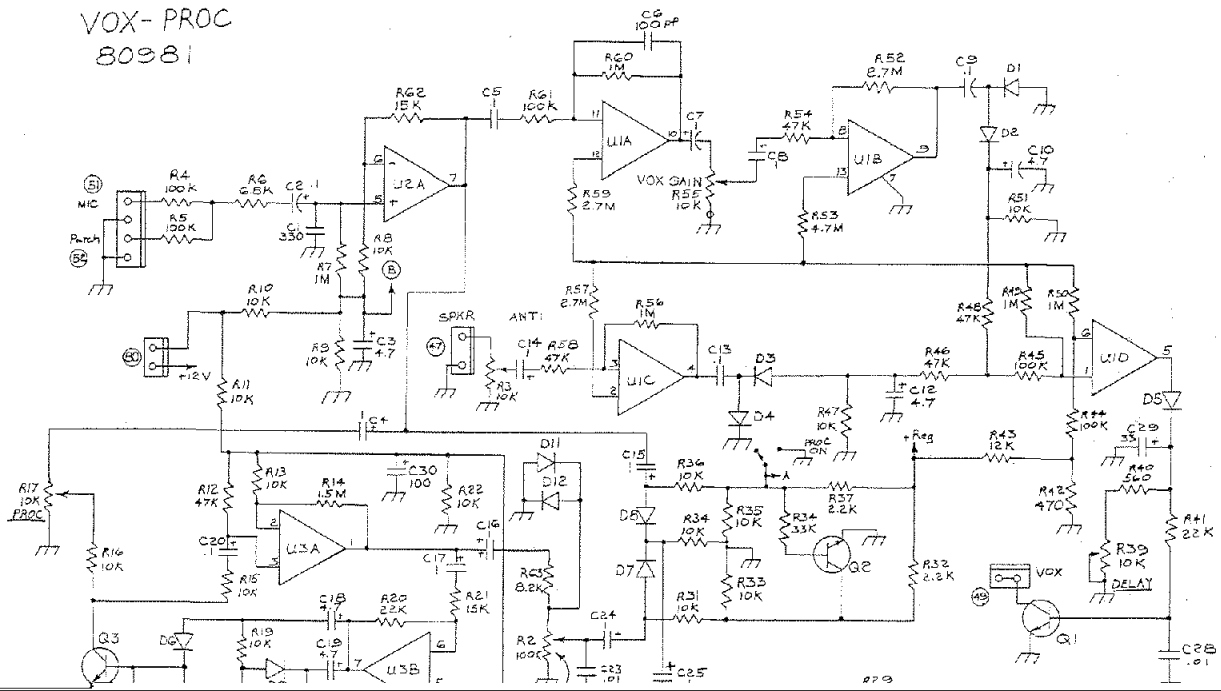

TEN-TEC KITS



QRP? Ten-Tec of course!

Single-band QRP CW rigs for 20, 30, 40, 80 meters. Single-conversion superhet receiver, full QSK operation, sidetone with matching offset, 3W output, 50 kHz of band coverage. Comes with all parts to build the rig and easy to follow instructions.

\$99 plus shipping.

Model 1056 single band direct conversion receiver kit. Build it for any 1 ham band from 10-160 meters. NE612 mixer. RF gain, main tuning, bandspread controls. MUTE input for use with a QRP TX. 12 VDC operation.

\$32 plus shipping.



1185 Dolly Parton Pkwy., Sevierville, TN 37862

Sales: 800-833-7373 www.tentec.com

Office (865) 453-7172. FAX (865) 428-4483.

Sales: Mon-Fri 8-5:30 EST sales@tentec.com.

Service: Mon-Fri 8-5 EST service@tentec.com (865) 428-0364.

TEN-TEC

DOUBLE SIDEBAND GENERATOR 80980

This assembly contains the carrier (BFO) crystal oscillator and a balanced modulator for double sideband generation. Transistor Q1 is the carrier oscillator at approximately 9 MHz. Its exact frequency is determined by which of the three trimmer capacitors C1, C2 or C3, are placed in the crystal circuit. C1 is in the circuit at all times and sets the carrier to the desired frequency on the high side of the crystal filter skirt. This position is used in the SB-R mode. In this mode, both C2 and C3 are removed from the crystal circuit by the transistor switches Q4 and Q3 respectively.

In the SB-N mode, both of these capacitors are inserted into the circuit by the MODE switch, and the three capacitors in parallel set the oscillator frequency down to the opposite (low frequency) side of the passband filter skirt. In the CW mode, C3 is removed by switch Q3 so that the carrier frequency increases by 750 Hz into the filter passband. The settings of C1 and C2 together determine this frequency.

Output from the carrier oscillator is fed to the BFO socket and to the balanced modulator U1 where it is mixed with the audio signal from the VOX board 80981. Output in the ssb mode is a double sideband, suppressed carrier signal, whose unwanted sideband is removed by the ladder filter on the noise blanker module.

For CW transmit operation, the balance of U1 is upset when the terminal CWU receives T voltage through the MODE switch. This is also the case in the LOCK mode. Audio from the microphone channel is eliminated by the same shorting procedure. The amount of T voltage, which is controlled by the setting of the DRIVE control in CW mode and applied to Pin 7 of the balanced modulator integrated circuit

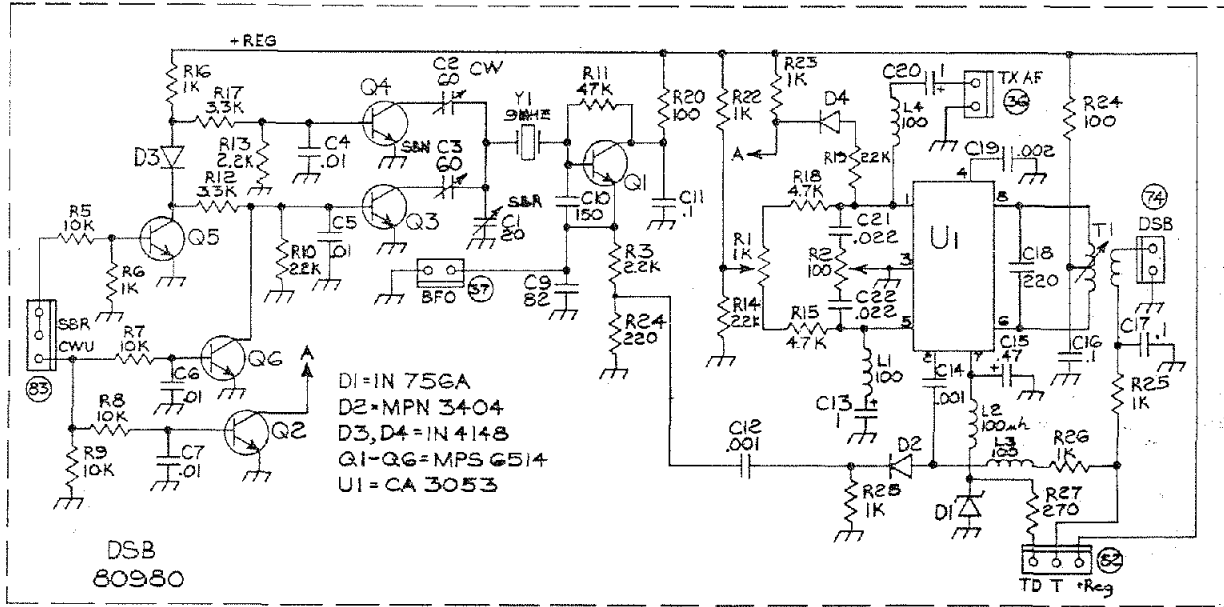

UI

PIN	RECEIVE	TRANSMIT
1	5.0	1.0
2	0	.25
3	0	0
4	0	0
5	3.0	4.5
6	7.5	7.5
7	0	.7
8	7.5	7.5

TRANSISTOR	COLLECTOR (drain)		BASE (gate)		EMITTER (source)	
	Receive	Transmit	Receive	Transmit	Receive	Transmit
Q1	7.4	7.4	4.5	5.0	4.95	5.0
Q2	7.5	0	0	.7	0	0
Q3	0	1.2	.65	0	0	0
Q4	0	0	.7	.7	0	0

LOW LEVEL DRIVER 81037

This assembly contains the transmit low level amplifier and the ALC circuit. Also, the signal into the bandpass filter is determined by the switching of PIN diodes D1 and D2. To adjust the action of the ALC LED indicator, place the MODE switch in the LOCK position and DRIVE control at full counterclockwise. Adjust R15 to a point just below where the LED begins to light. Using a wattmeter and dummy load, advance the DRIVE control until 100 watts is indicated on 14.05 MHz. Adjust the front panel ALC control for full clockwise rotation and then adjust R11 so that the LED is fully bright with 100 watts output.



The high power rf amplifier and its push-pull drive stage are housed in a metal box which is an integral part of the heat sink assembly. The unit is attached to the back panel with four screws.

Q1 and Q2 constitute a Class AB linear push-pull driver stage of wide band design. Impedance matching into and out of this stage is by means of transformers T1 and T2. Bias is applied whenever "T" voltage is applied to the terminal so marked, and quiescent current in the collector circuit is adjusted to a value of between 4 and 8 mA with potentiometer R11. Access to this control is by means of the small hole in the brass box as shown on Figure 1 of this section. To adjust bias, unsolder the small jumper red wire connecting the second small feed through terminal to the large +12 volt lug. Insert a dc milliammeter between the two, set DRIVE control fully CCW and MODE switch to LOCK position. If driver collector current is not between the recommended limits, readjust trimpot (clockwise to increase current) by rotating the trimpot plastic serrated knob through the shield box hole with the aid of a small awl type probe.

Power amplifier transistors Q3 and Q4 are also in a Class AB push-pull arrangement. Bias is applied to the bases in a shunt feed system through L2 and L3. Bias is fed to this stage from a regulated and controlled supply on the cover of the amplifier box.

Bias for both stages is temperature compensated to maintain a relatively constant operating point by mounting the bias diodes in direct contact with the heat sink. D1 controls the driver stage and D2 the output stage.

Final amplifier bias is adjusted by R23. To adjust bias, place a DC ammeter in the +13 V dc supply lead. Load into a dummy load, set MODE switch to LOCK position and DRIVE control fully counterclockwise. Note the current reading and then slowly rotate R23 in the direction that decreases the current reading. After determining which direction decreases current, set the control fully in this direction. This will cut off the final transistors. Note the current reading and then advance R23 so that the reading increases by $\frac{1}{2}$ ampere-no more. This value should be approximately $1\frac{1}{2}$ amperes total. Too low a bias setting will cause distorted audio in sideband due to amplifier operating class C. Too high a quiescent current will increase power dissipation in the output transistors.

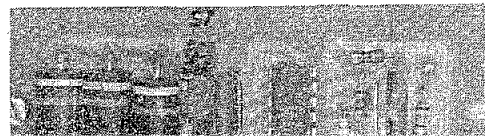

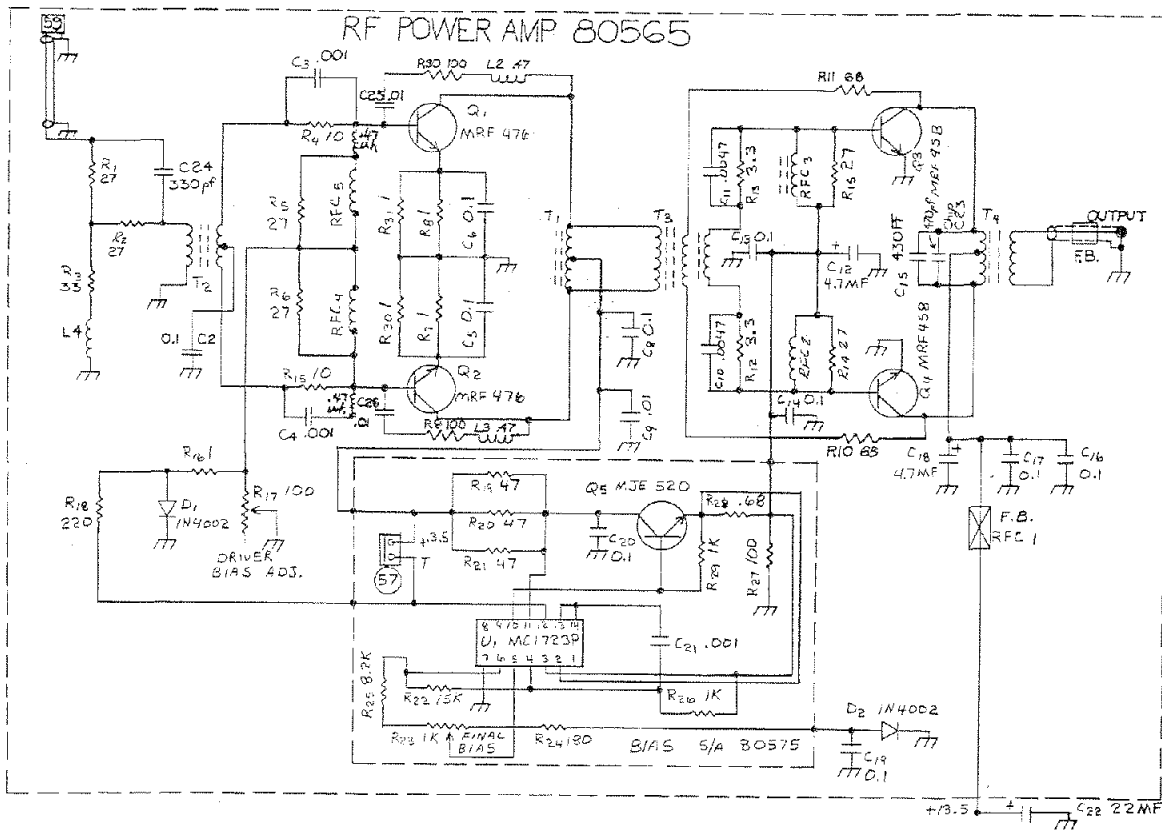

BANDPASS FILTER 80976

This assembly contains individual bandpass filters for each band. They consist of critically or over-coupled tuned circuits, 3 poles on each band except 10 and 15 meters. Because the tuning of these circuits is critical and they are used both when receiving and transmitting, these resonant circuits are best aligned using a sweep oscillator system. Realignment is seldom necessary except when a tuned circuit component has been replaced. Since all of the components are passive, no voltage measurements are required.



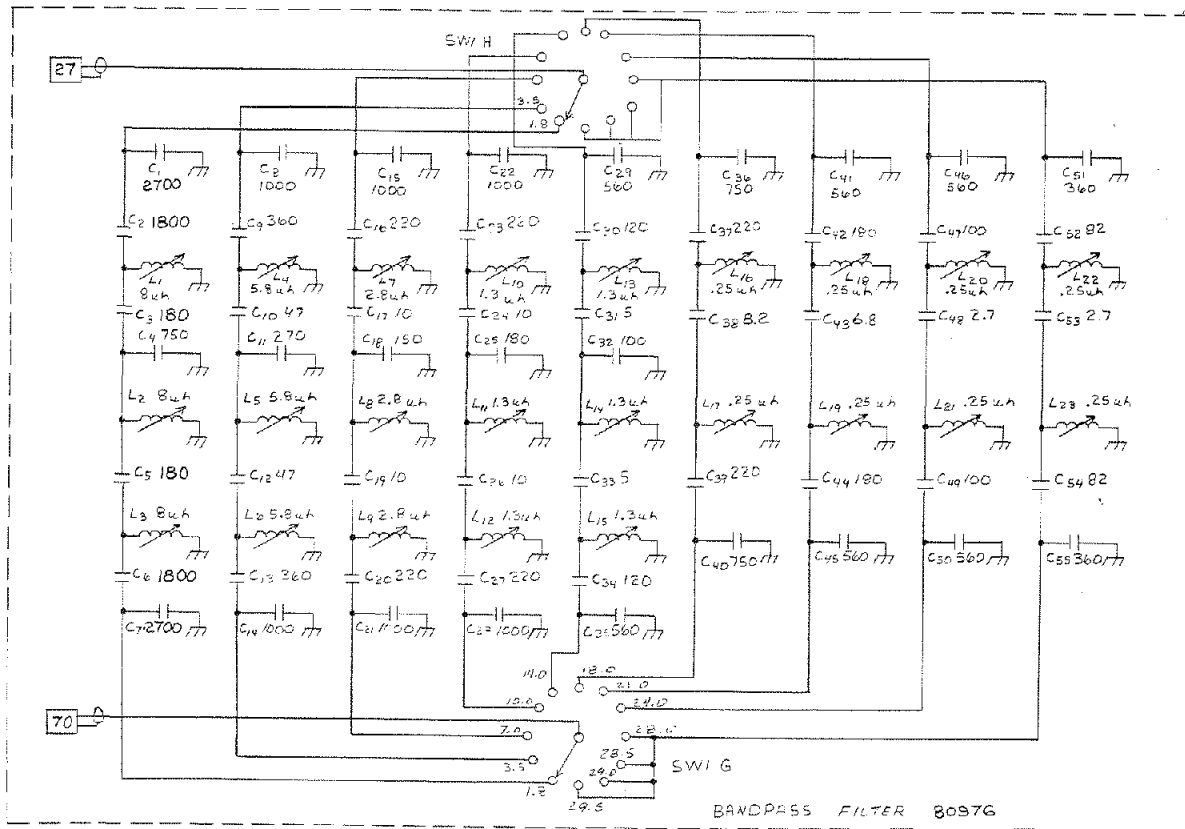

LOW PASS FILTER 80969

This assembly contains the low pass output filters and the electronic TR switch. The output signal from the final rf amplifier contains harmonic components above the desired level. To attenuate these harmonics to a suitable level, the signal is passed through a 5 pole low pass filter before being radiated. The proper filter is selected by the bandswitch. The final amplifier is disconnected from the antenna circuit during receive by relay K1. Switching of the receive antenna is performed by switch Q1 and diodes D1, and D2. This allows extremely fast switching of the antenna and permits full break-in operation on cw. PIN diodes D1 and D2 connect the antenna to the receiver input when receiving, and are back biased by a voltage rectified by D3 through D6 on transmit. There are no user adjustments on this board.

SWR BOARD 80970

This board contains the SWR, power, and ALC sensing circuits. The bridge balance control, C1, is adjusted through an access hole on the right side panel. The SWR meter is calibrated by placing an additional 50 ohm load in parallel with an existing 50 ohm load and adjusting R1 for an SWR meter reading of 2:1. With the meter switch in the forward power setting, adjust R2 to agree with an external calibrated wattmeter.

TRANSISTOR	COLLECTOR		BASE		EMITTER	
	Receive	Transmit	Receive	Transmit	Receive	Transmit
Q1 2N6519	7.80	-.15	7.96	.35	8.71	.72
Q2 2N6514	.05	0	0	.79	0	0

DIGITAL READOUT

The frequency counter and digital display section of the CORSAIR consists of two interconnected printed circuit assemblies located in an aluminum enclosure which is secured to the front subpanel. The large scale integrated circuit, display interface circuitry, a 10-1 prescaler, and a 5 volt regulator are mounted on the counter logic board 80973. The remaining circuits for the counter timebase and pre-amp are mounted on the pre-amp board 80974.

This portion of the transceiver is highly complex and contains MOS and CMOS integrated circuits that are susceptible to damage from static burnout if improperly handled. There are no user servicable components inside.

The counter counts the actual VFO frequency being applied to the first mixer, and assumes that the RFQ frequency is either 9 or 9.003 MHz. This is the case for sideband normal and sideband reverse re-

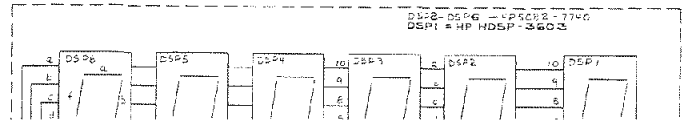
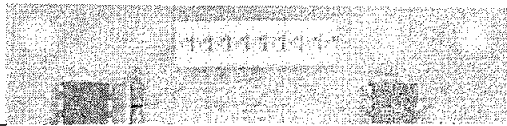
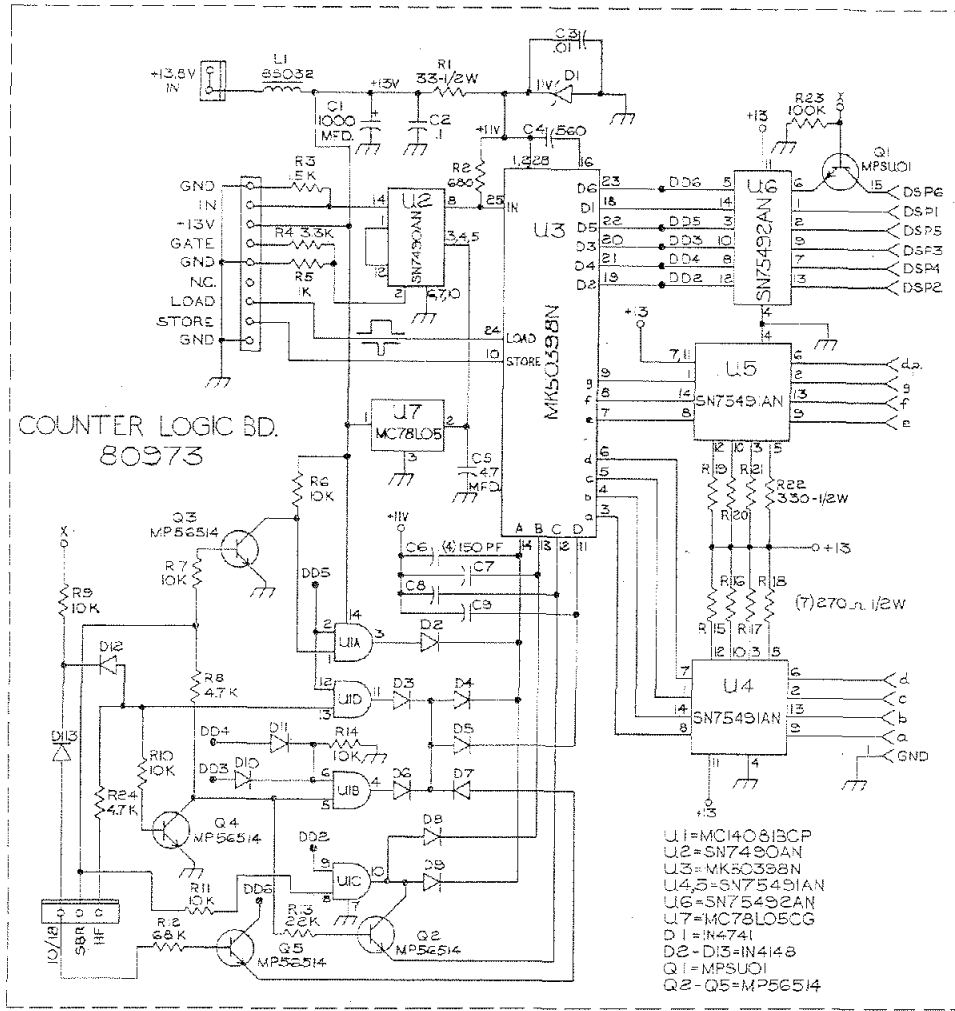

Kings of Shortwave Radio



RX-340 "The Ultimate"

The Ultimate HF SWL receiver. 50 kHz–30 MHz. IF stage DSP. Sync AM/selectable sideband, SAM, AM, SSB, ISB, CW, FM. 57 bandwidth filters, programmable AGC, built-in high stability TCVCXO. Completely remote controllable via RS-232 interface. DRM reception capable with no modification needed. 115/230 VAC operation.

\$3,950



1185 Dolly Parton Parkway

Sevierville, TN 37862

Sales Dept: 800-833-7373

Monday - Friday 8:00 - 5:30 EST

We accept VISA, Mastercard,

American Express, and Discover

Office: (865) 453-7172 • FAX: (865) 428-4483

Repair Dept.: (865) 428-0364 (8 - 5 EST)

www.tentec.com



RX-320D PC Radio

New model RX-320D adds a 12 kHz I-F output for decoding DRM transmissions to the world famous RX-320 PC Radio. General coverage HF from 100 kHz–30 MHz. "Black box" receiver connects to your PC via one serial port. Your PC provides the operation horsepower. Download the actual operating software from our web site for a pre-purchase test drive.

\$329

**Call
Toll-Free
(800) 833-7373**

Europe: All Ten-Tec shortwave receivers are CE marked.



RX-350

RX-350 is a full-featured HF DSP receiver for today's demanding shortwave listener. 100 kHz–30 MHz. Modern IF-DSP architecture accommodates 34 built-in bandwidth filters, DSP automatic notch, and DSP noise reduction. Flash ROM updateable via Internet file downloads. Large LCD graphics panel for display of all receiver functions. Selectable sideband/Sync AM, SAM, AM, FM, CW, and SSB modes. Momentary SWEEP function shows band activity on LCD screen. 1024 memories. Timer and squelch activation circuitry. 12/24-hour clock. Hi Z and Lo Z antenna inputs. 115/230 VAC or 13.8 VDC operation.

\$1,199

302 REMOTE/ENCODER KEYPAD

Allows armchair tuning of the RX-350. Function buttons allow operation of various receiver controls. Direct frequency entry via keypad.

\$139



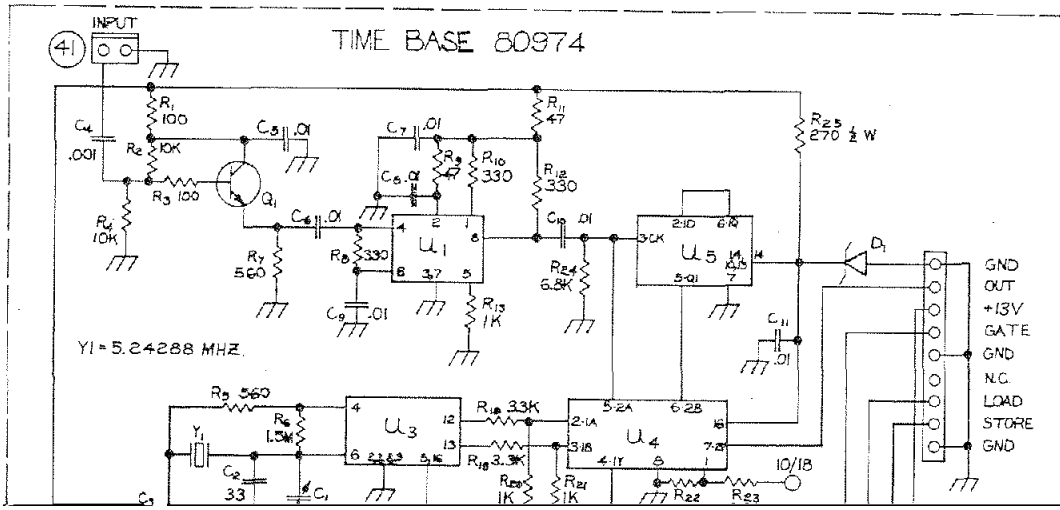

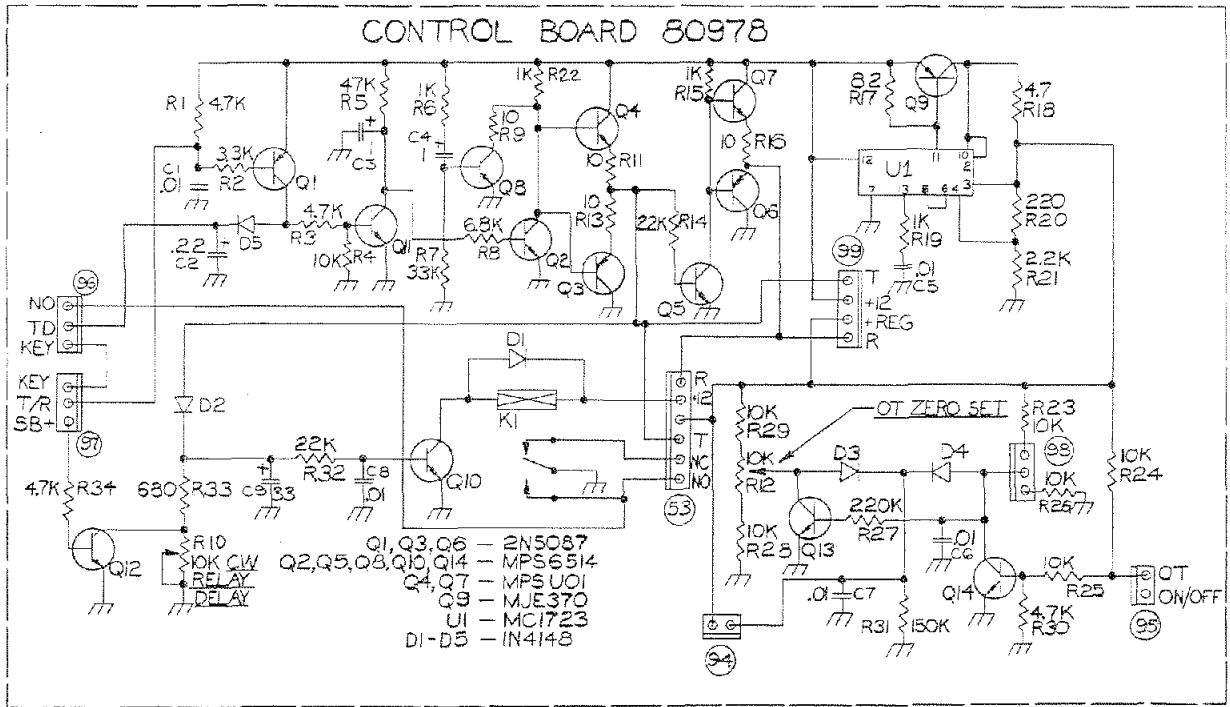

U1

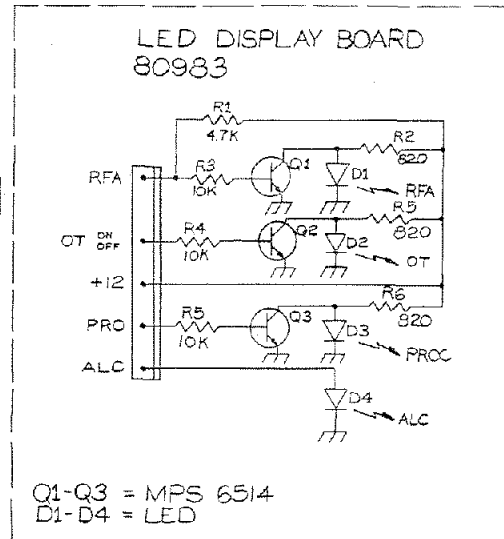
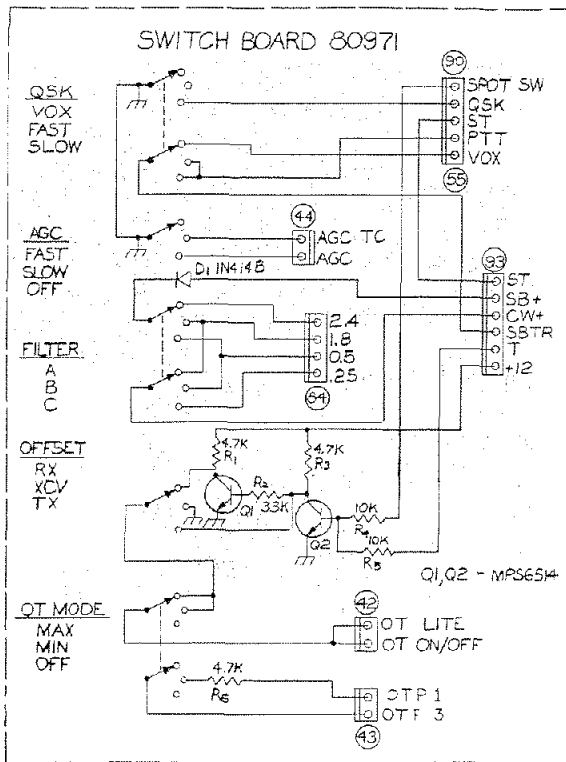
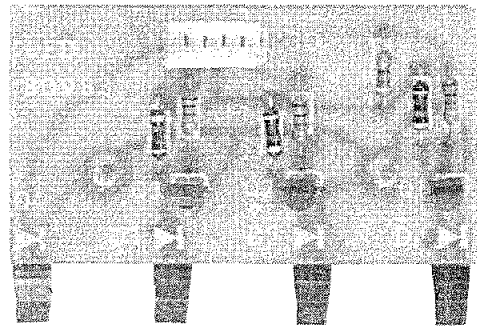
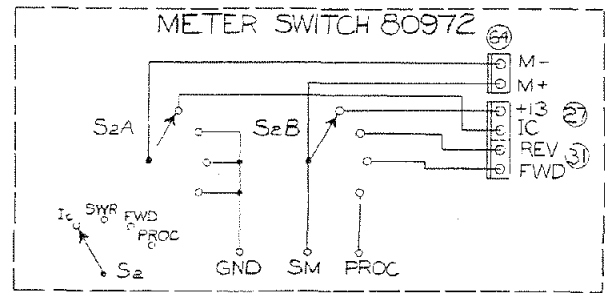
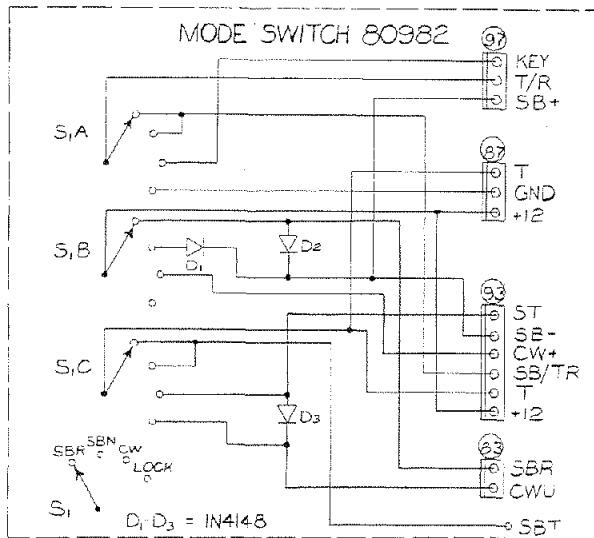

SW-2 80971

TRANSISTOR	COLLECTOR		BASE		EMITTER	
	Receive	Transmit	Receive	Transmit	Receive	Transmit
Q1	0	13	.7	0	0	0
Q2	9	0	0	.1	0	0

PARTS LISTS

PARTS LISTS contd.

<u>Circuit Board</u>	<u>Ten-Tec Part #</u>	<u>Description</u>
----------------------	-----------------------	--------------------

<u>80547</u>		
<u>COUNTER DISPLAY</u>		
DISP1-DISP6	28028	HP-7740

<u>80978</u>		
<u>CONTROL BOARD</u>		
Q1,Q3,Q6	25001	2N5087
Q2,Q5,Q10-		
Q14	25054	MPS-6514
Q4,Q7,Q8	25053	MPS-U01
Q9	25105	MJE-370
U1	25050	MC1723P
D1-D5	28001	IN4148

<u>80983</u>		
<u>LED DISPLAY</u>		
Q1-Q3	25054	MPS-6514
D1-D4	28036	HMLP-3033 LED

Ten-Tec, Inc.

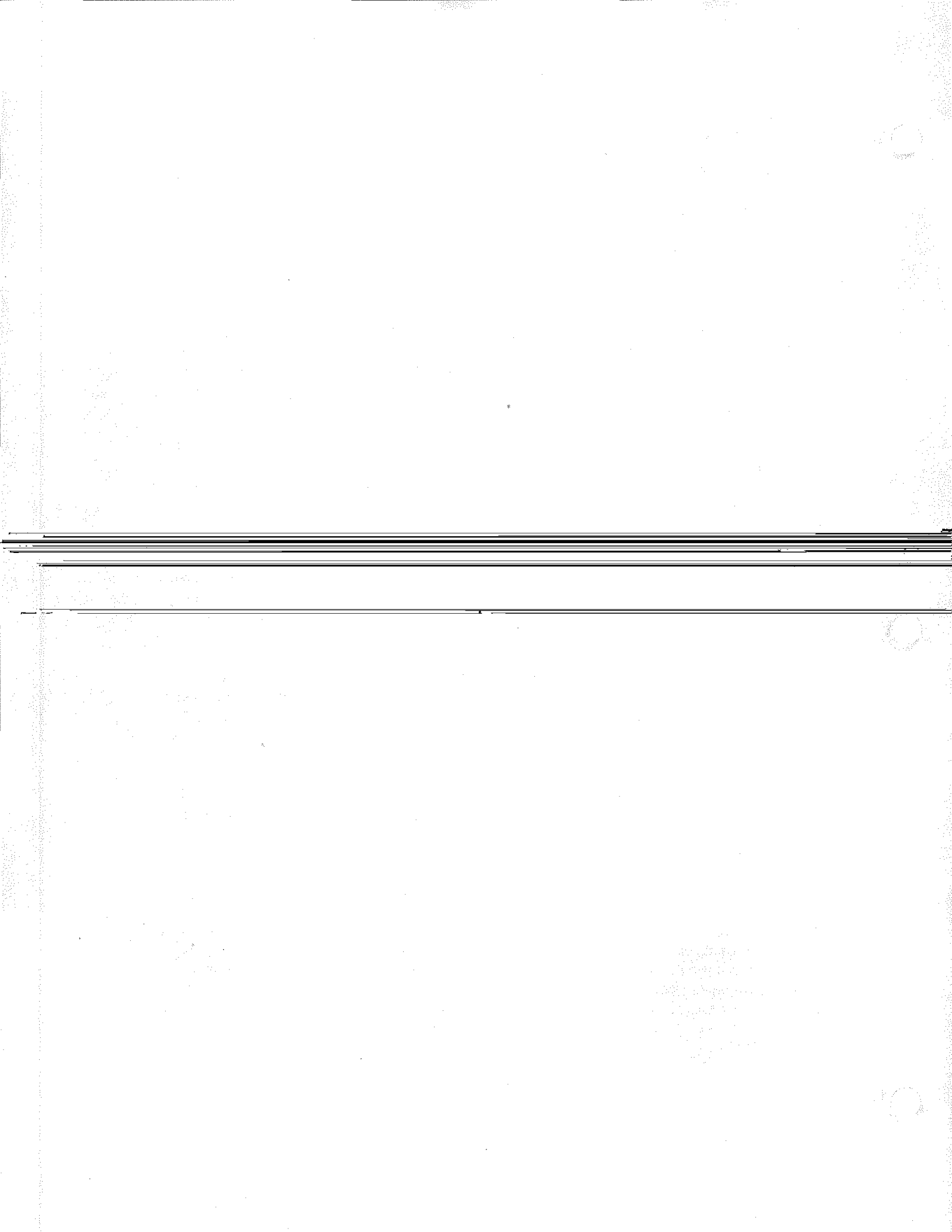

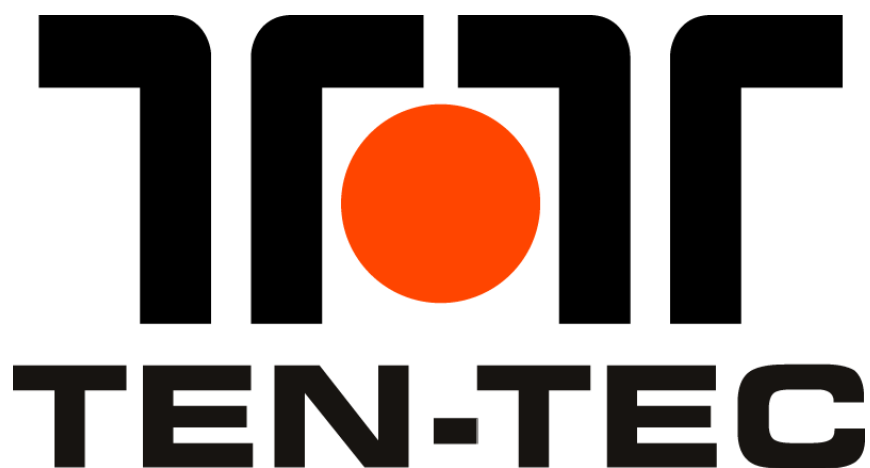

This obsolete manual file is provided as a courtesy to you by Ten-Tec, Inc.

Ten-Tec's service department can repair and service virtually everything we have built going back to our first transceivers in the late 1960's. It is our ability to continue offering service on these rigs that has led to their re-sale value remaining high and has made a major contribution to our legendary service reputation.

Printed and bound copies of all manuals are available for purchase through our service department if you would prefer not to use this copy as your transceiver manual.

We can repair or service your Ten-Tec equipment at our facility in Sevierville, TN. We also offer support via telephone for all products via during usual business hours of 8 a.m. to 5 p.m. USA Eastern time, Monday through Friday. We have a large supply of parts for obsolete products. Repairing a transceiver or amplifier yourself? Contact us for parts pricing information.

**Service department direct line: (865) 428-0364
Ten-Tec office line: (865) 453-7172
Service department email: service@tentec.com
Address: 1185 Dolly Parton Parkway, Sevierville, TN 37862 USA**

We have found it is most effective for us to help you troubleshoot or repair equipment with a consultation via telephone rather than by email.

Suggested contact methods are:

**Troubleshooting or repairing equipment – call (865) 428-0364
Other inquiries – call (865) 428-0364 or email service@tentec.com**

THANK YOU AND 73 FROM ALL OF US AT TEN-TEC