

HF & V/UHF Band
All Mode Mobile Transceiver

FT-100/-100D

Technical Supplement

©2003 VERTEX STANDARD CO., LTD. E089890A

VERTEX STANDARD CO., LTD.
4-8-8 Nakameguro, Meguro-Ku, Tokyo 153-8644, Japan
VERTEX STANDARD
US Headquarters
10900 Walker Street, Cypress, CA 90630, U.S.A.
International Division
8350 N.W. 52nd Terrace, Suite 201, Miami, FL 33166, U.S.A.
YAESU EUROPE B.V.
P.O. Box 75525, 1118 ZN Schiphol, The Netherlands
YAESU UK LTD.
Unit 12, Sun Valley Business Park, Winnall Close
Winchester, Hampshire, SO23 0LB, U.K.
VERTEX STANDARD HK LTD.
Unit 5, 20/F., Seaview Centre, 139-141 Hoi Bun Road,
Kwun Tong, Kowloon, Hong Kong

Introduction

This manual provides technical information necessary for servicing the Yaesu FT-100/-100D HF & V/UHF-Band Transceiver. It does not include information on installation and operation, which are described in the FT-100/-100D Operating Manual provided with the transceiver, or on accessories which are described in their manuals.

The FT-100/-100D is carefully designed to allow the knowledgeable operator to make nearly all adjustments required for various station conditions, modes and operator preferences simply from the controls on the panels, without opening the case of the transceiver. The FT-100/-100D Operating Manual describes these adjustments, plus certain internal settings.

Servicing this equipment requires expertise in handling surface mount chip components. Attempts by unqualified persons to service this equipment may result in permanent damage not covered by warranty. For the major circuit boards, each side of the board is identified by the type of the majority of components installed on that side. In most cases one side has only chip components, and the other has either a mixture of both chip and lead compo-

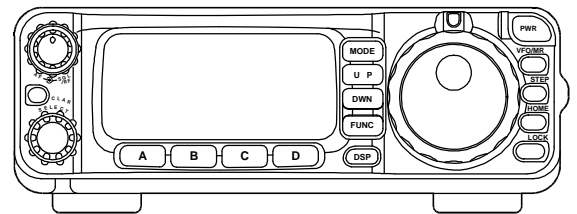

nents (trimmers, coils, electrolytic capacitors, packaged ICs, etc.), or lead components only.

While we believe the technical information in this manual is correct, VERTEX STANDARD assumes no liability for damage that may occur as a result of typographical or other errors that may be present. Your cooperation in pointing out any inconsistencies in the technical information would be appreciated. VERTEX STANDARD reserves the right to make changes in this transceiver and the alignment procedures, in the interest of technological improvement, without notification of owners.

Contents

Specification	2	LOCAL Unit	63
Exploded View & Miscellaneous Parts	3	REF Unit	75
Alignment	5	PA Unit	77
Block Diagram	17	LPF Unit.....	89
Interconnection Diagram	18	DISPLAY Unit.....	99
Board Unit (Schematics, Layouts & Parts)		CNTL Unit.....	107
MAIN Unit.....	19	CONNECT-1 Unit	117
6m-FILTER Unit	49	VR Unit	118
BPF Unit	51	CONNECT-2 Unit	119
HPF Unit	55	Option	120
AUDIO-FILTER Unit.....	59	TCXO-8	120
		FTS-27	121

Specifications

General

Frequency Range:

Receive 100 kHz – 970 MHz (European version)
100 kHz – 824 MHz, 849 – 864 MHz,
and 894 – 961 MHz (U.S.A version)

Transmit 160 – 6 Meters
2 Meters
70 Centimeters (Amateur bands only)
5167.5 kHz: Alaska Emergency Frequency
(U.S.A. version only)

Emission Modes:

A1 (CW), A3 (AM), A3J (LSB/USB),
F1 (9600 bps Packet), F2 (1200 bps Packet), F3 (FM)

Synthesizer Steps (Min.):

1.25 Hz (CW/SSB), 100 Hz (AM), 100 Hz (FM),
1 kHz (FM)

Antenna Impedance:

50Ω, Unbalanced

Operating Temp. Range:

-10 °C to +60 °C (14 °F to 122 °F)

Frequency Stability:

Better than ±4 ppm (-10 °C to +50 °C) (SSB/CW/AM)
Better than ±{1 kHz +4 ppm} (FM)

Power Requirements:

DC 13.8V ± 10%, Negative Ground

Current Consumption:

Receive (Squelched): 1.2A, Receive (Max. Audio): 1.6A
Transmit: 22A (@ 100W RF output)

Case Size:

160(W) x 54(H) x 205(D) mm (6.3" x 2.2" x 8.0" WHD)

Weight:

3 kg. (6.6 lb.)

Transmitter

Power Output:

160 – 6m: 100 Watts (25 Watts AM carrier)
2m: 50 Watts (12.5 Watts AM carrier)
70cm: 20 Watts (5 Watts AM carrier)

Modulation Types:

SSB: Balanced Modulator
FM: Variable Reactance
AM: Early Stage (Low Level)

FM Maximum Deviation:

±5 kHz (±2.5 kHz on FM-N)

Spurious Radiation:

Harmonics: At least 40 dB down (1.8 – 29.7 MHz)
At least 60 dB down (50/144/430 MHz)
Non-harmonic: At least 50 dB down (1.8 – 29.7 MHz)
At least 60 dB down (50/144/430 MHz)

Carrier Suppression:

At least 40 dB

Opp. Sideband Suppression:

At least 50 dB

SSB Frequency Response:

400 Hz – 2600 Hz (-6 dB)

Microphone Impedance:

200Ω – 10kΩ (Supplied microphone: 2kΩ)

Receiver

Sensitivity:

	SSB/CW	AM-N	FM
100 kHz – 150 kHz:	–	–	–
150 kHz – 250 kHz*:	5 μV	40 μV	–
250 kHz – 1.8 MHz*:	4 μV	32 μV	–
1.8 – 28 MHz*:	0.25 μV	2 μV	–
28 – 30 MHz:	0.25 μV	2 μV	0.50 μV
50 – 54 MHz:	0.20 μV	2 μV	0.50 μV
144/430 MHz:	0.125 μV	2 μV	0.20 μV

Above specifications are worst-case.

SSB/CW/AM-N figures are for 10 dB S/N, 12 dB SINAD on FM.

**: IPO off*

Squelch Sensitivity:

	SSB/CW/AM	FM
1.8 – 28 MHz:	2.5 μV	–
28 – 30 MHz:	2.5 μV	0.32 μV
50 – 54 MHz:	1.12 μV	0.20 μV
144/430 MHz:	0.8 μV	0.16 μV

Intermediate Frequencies:

1st IF: 68.985 MHz (SSB/CW/FM/Digital)
67.980 MHz (W-FM)
2nd IF: 11.705 MHz (SSB/CW/FM/Digital)
10.700 MHz (W-FM)
3rd IF: 455 kHz (FM)

Image Rejection:

Better than 70 dB (1.8 – 30 MHz, 50 – 54 MHz)
Better than 60 dB (144 – 148 MHz, 430 – 440 MHz)

IF Rejection:

Better than 70 dB (1.8 – 30 MHz)
Better than 60 dB (50 – 54 MHz, 144 – 148 MHz,
430 – 440 MHz)

Selectivity (-6/-60 dB):

SSB/CW: 2.2 kHz/5.2 kHz
CW: 450 Hz/1.8 kHz
(FT-100: Optional XF-117C installed)
CW-N: 250 Hz/1.2 kHz
(Optional XF-117CN installed)
AM: 5.2 kHz/18 kHz
(Optional XF-117A installed)
FM: 15 kHz /25 kHz (-6/-50 dB)

Audio Output:

At least 1.5W into 8Ω @ 10% THD

Audio output impedance:

4Ω – 8Ω

Specifications are subject to change without notice, and are guaranteed within amateur bands only.

Exploded View & Miscellaneous Parts

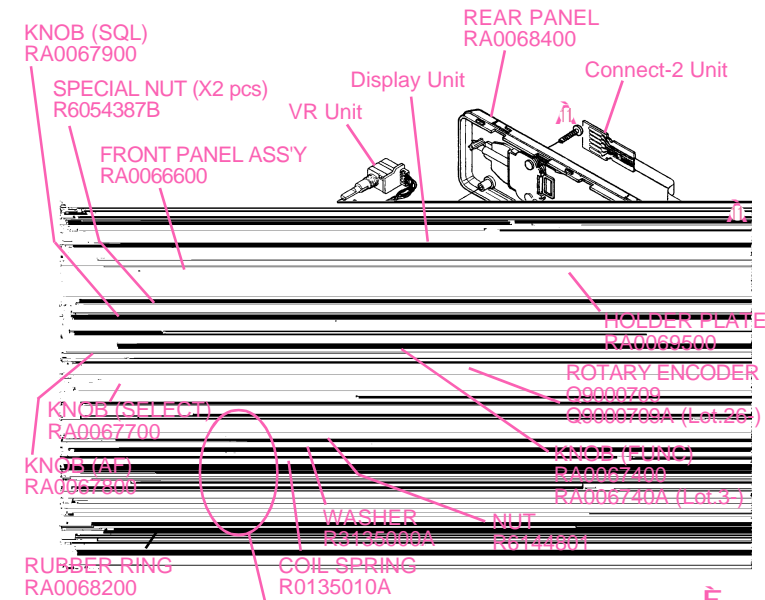

REF.	VXSTD P/N	Description	Qty.
A	U02308001	SEMS SCREW SM3x8	10
A	U03306001	SEMS SCREW ASM3x6	1
A	U07430107	PAN HEAD SCREW M2.6x3B	1
A	U20318007	BINDING HEAD SCREW M3x18B	8
A	U20406007	BINDING HEAD SCREW M4x6B	2
A	U24204001	TAPTITE SCREW M2.6x4	3
E	U24206001	TAPTITE SCREW M2.6x6	25
C	U31203007	OVAL HEAD SCREW M2.6x3B	4
E	U31206007	OVAL HEAD SCREW M2.6x6B	12
E	U34206001	TAPTITE SCREW M2.6x6	4
A	U43112007	TAPTITE SCREW M2x12B	2

Non-designated parts are available only as part of a designated assembly.

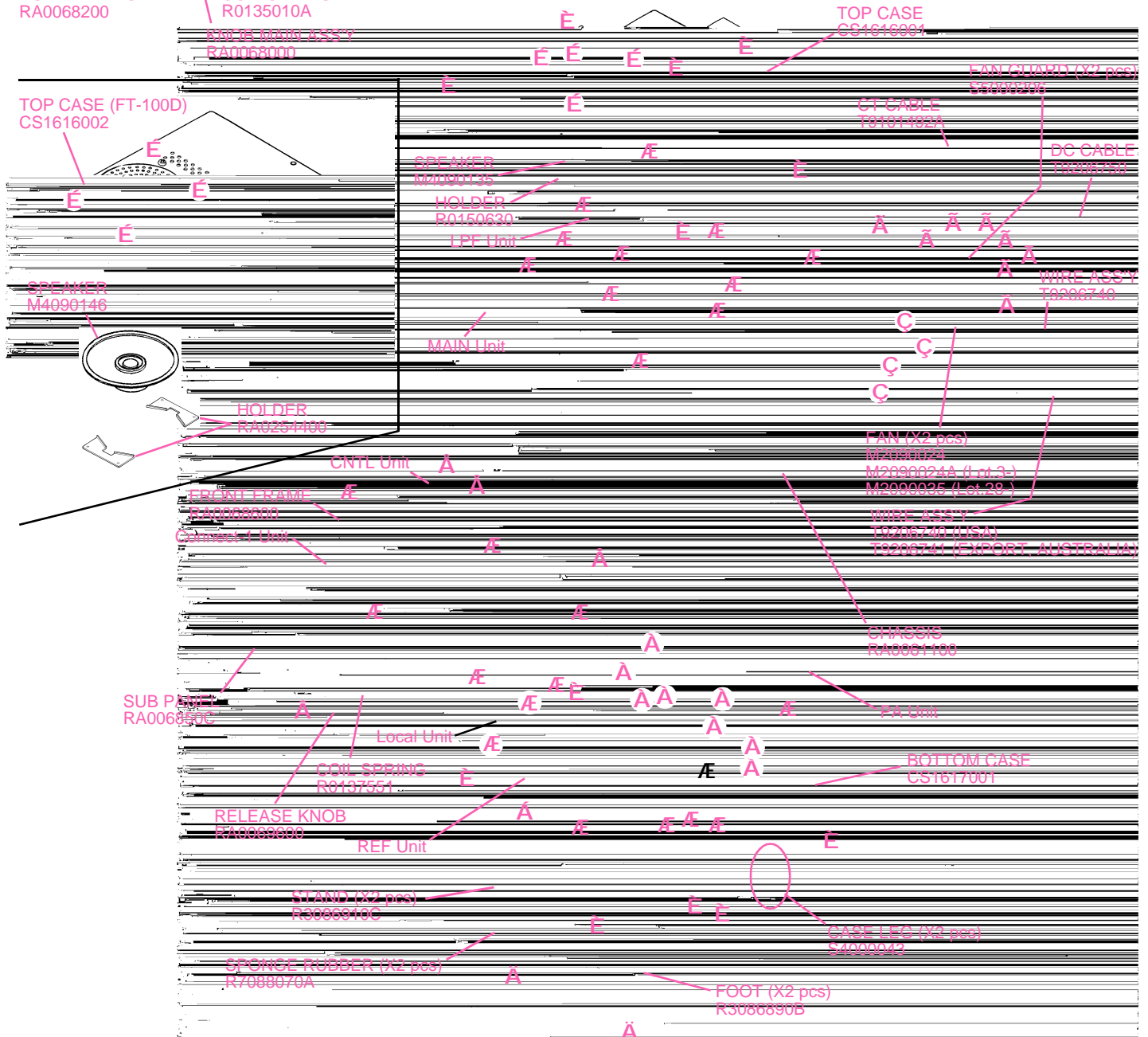

Exploded View & Miscellaneous Parts

REF.	DESCRIPTION	VALUE	V/W	TOL.	MFR'S DESIG	YAESU P/N	VERS.	LOT.	SIDE
*** MAIN ASSY ***									
C 0001	AL.ELECTRO.CAP.	100uF	16V		SMG1CVB101M 100UF	K40129060		2-	
FN0001	FAN				JF0410S1HB-086 DC12V	M2090024		1-	
FN0001	FAN				JF0410S1HB-175 DC12V	M2090024A		3-	
FN0001	FAN				KF0410S1H-175 DC12V	M2090035		28-	
FN0002	FAN				JF0410S1HB-086 DC12V	M2090024		1-	
FN0002	FAN				JF0410S1HB-175 DC12V	M2090024A		3-	
FN0002	FAN				KF0410S1H-175 DC12V	M2090035		28-	
L 0001	TOROIDAL CORE				ESD-R-12C	L9190069		2-	
L 0002	FERRITE BEADS				FSOC171RT01B	L9190116		2-	
L 0003	FERRITE BEADS				ESD-FPL-13	L9190114		2-	
P 0001	WIRE ASSY				A0898 #241890	T9206734		1-	
P 0003	WIRE ASSY				A0898 #241891	T9206735		1-	
P 0005	WIRE ASSY				A0898 #241892	T9206736		1-	
P 0007	WIRE ASSY				A0898 #241888	T9206732		1-	
P 0009	WIRE ASSY				A0898 #241887	T9206731		1-	
P 0011	WIRE ASSY				A0898 #241889	T9206733		1-	
P 0013	WIRE ASSY				A0898	T9206744		1-	
P 0014	CT CABLE				8P-4PX2 530MM	T9101492		1-	
P 0014	CT CABLE				8P-4PX2 530MM	T9101492A		2-	
P 0016	WIRE ASSY				A0898 M	T9206740	USA	1-	
P 0016	WIRE ASSY				A0898 N	T9206741	EXPORT	1-	
P 0016	WIRE ASSY				A0898 N	T9206741	AUSTRALIA	1-	
P 0017	WIRE ASSY				A0898 M	T9206740		1-	
P 0018	WIRE ASSY				A0898	T9206750		1-	
P 0101	WIRE ASSY				GRA 240 TMP/TMP	T9309401		1-	
P 0101	WIRE ASSY				GRA 235 TMP/TMP	T9318095		2-	
P 0103	WIRE ASSY				RED 290 TMP/TMP	T9311404		1-	
P 0103	WIRE ASSY				RED 265 TMP/TMP	T9318096		2-	
P 0105	WIRE ASSY				GRA 200 TMP/TMP	T9311403		1-	
P 0107	WIRE ASSY				ORG 210 TMP/TMP	T9317850		1-	
P 0109	WIRE ASSY				RED 300 TMP/TMP	T9311408		1-	
P 0111	WIRE ASSY				RED 170 TMP/TMP	T9318092		2-	
P 0113	WIRE ASSY				GRA 138 TMP/TMP	T9318097		2-	
S 0001	ROTARY ENCODER				RES20D50-201-1D	Q9000709		1-	
SP0001	SPEAKER				VS-50-0827B 1.5W/8-OHM	M4090135		2-	

Alignment

Introduction and Precautions

m Ω

m Ω

m

Ω

m

m

m

m

Alignment Preparation & Precautions

Ω

m AF

m SQL/RF

A B C

FUNC

FUNC

Required Test Equipment

m

Ω

m

m

m

m

m

m Ω

Notes: Signal levels in dB referred to in alignment are based on
0 dBμ = 0.5 μV (closed circuit).

Table Note: DC voltages should be within ±10 % of those listed
in the voltage tables.

Alignment

Local Oscillator Adjustments

Reference Frequency Adjustment

m

m

m

2nd Local Adjustment

m Ω

m

m

3rd Local Adjustment

m Ω

m

m

m

PLL Adjustments

VCO VCV Adjustment

m

Tune to:	Adjust/Confirm	For

1st Local Output Level

m Ω

Tune to:	For

PA Unit Adjustments

Ω

HF/50MHz Driver Section Idling Current

m Ω

m

m

m

m

m

m

HF/50 MHz Final Idling Current Adjustment

m Ω

m

m

m

VHF/UHF Driver Section Idling Current

m Ω

m

m

m

m

m

VHF/UHF Final Idling Current Adjustment

144/430 MHz Band RX IF Sensitivity

m

m

Ω

Ω

m

m

m

144 MHz Band Front End Gain (Preset)

m

m

TX and RX IF Adjustments

430 MHz Band Front End Gain (Preset)

HF Band RX IF Sensitivity (Coarse Adjust)

m

m

HF Band RX IF Gain Adjustment

m

m

Ω

m

m

m

m

m

DIAL

1st Mixer Balance

50 MHz Band RX Gain Adjustment

m

m

m

m

m

HF/50 MHz Band RX IF Sensitivity

m

DIAL

m

Ω

144 MHz Band RX Gain Adjustment

m

m

m

m

m

Alignment

m

DIAL

430 MHz Band RX Gain Adjustment

m

m

m

m

DIAL

S-meter Full Scale Alignment

m

m

m

m

DIAL

Squelch Threshold Level Adjustment

m

m

DIAL

m

DIAL

m

DIAL

Noise Blanker Alignment

m

m

NB

NB

m

TX Adjustments

HF/50 MHz band TX IF Transformers

m

Ω

m

m

144/430 MHz band TX IF Transformers

m

Ω

m

m

Trap Adjustment

m

m

m

CM Coupler Balance

m

Ω

m

m

Ω

m

m

Alignment

m

144 MHz band Output Power Adjustment

m Ω

HF/ 50 MHz Band Over-Current ALC Adjustment

m Ω

m

DIAL

m

DIAL

430 MHz band Output Power Adjustment

m Ω

VHF/UHF Band Over-Current ALC Adjustment

m Ω

m

DIAL

m

DIAL

HF band Output Power Adjustment

m Ω

TX Gain Adjustment

m Ω

m

DIAL

m

m

DIAL

DIAL

m

DIAL

50 MHz band Output Power Adjustment

m Ω

m

DIAL

m

DIAL

m

DIAL

Tune to	Menu #	For

Alignment

ALC Meter Sensitivity

m Ω

m

m

m

DIAL

PO Meter Sensitivity

m Ω

m

Tune to	Menu	For

REV ALC Adjustment

m Ω Ω

m

m

DIAL

Tune to:	Menu	For

m

m

DIAL

Tune to:	Menu	For

SWR Meter Adjustment

m Ω Ω

m

m

DIAL

CW Carrier Level Adjustment

m Ω

m

m

DIAL

AM Carrier Level Adjustment

m Ω

m

minimum

m

DIAL

FM Maximum Deviation

m Ω

m

m

m

Alignment

m

m

m

m

DIAL

m

m

m

m

m

Ω

m

m

m

m

DIAL

m

DIAL

m

m

TX and RX Carrier Point Adjustment

m

Ω

BEEP Level

m

m

m

fre-

quency

level

Alignment

Note:

MAIN-Unit Alignment Points

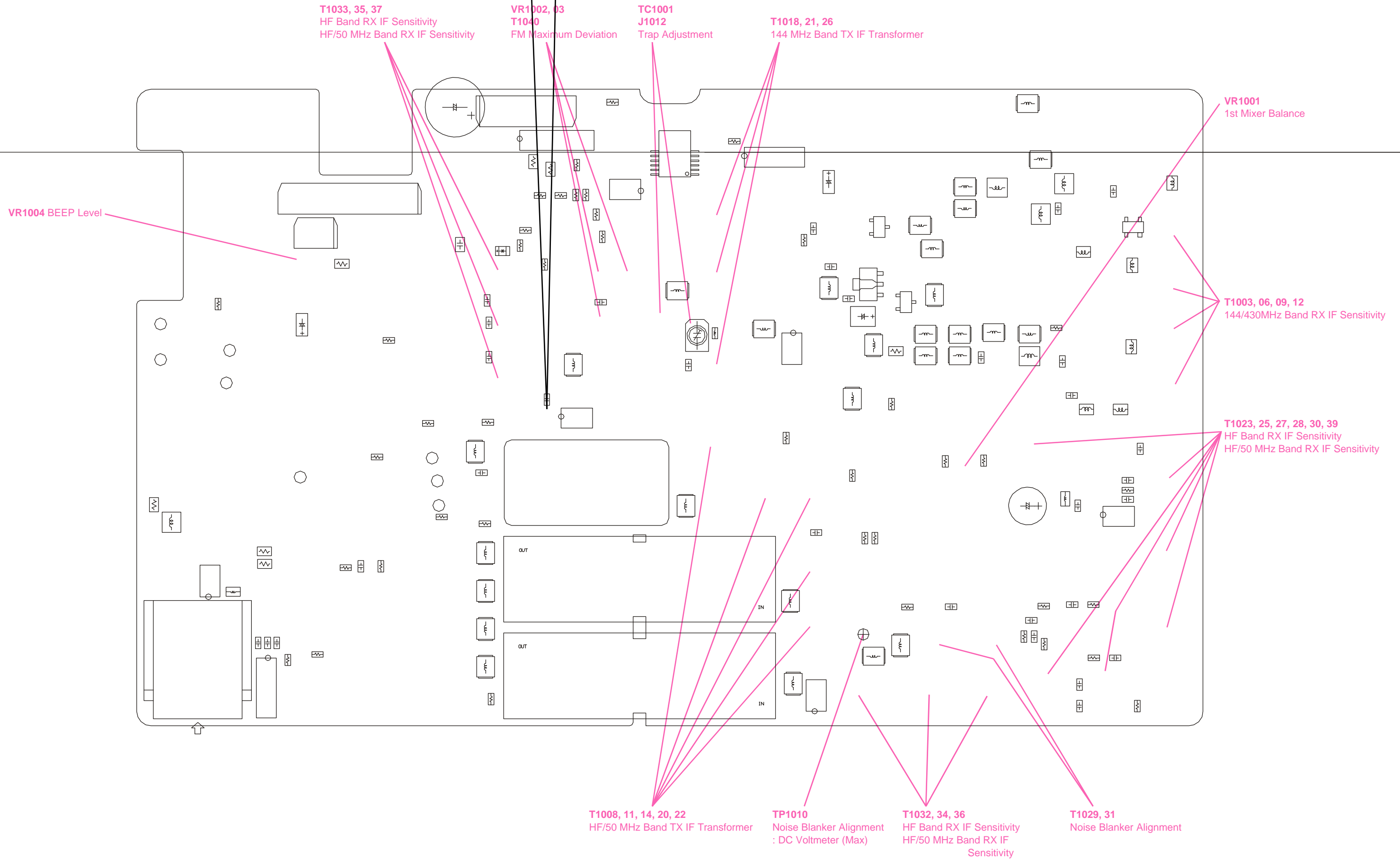

Alignment

Local-Unit Alignment Points

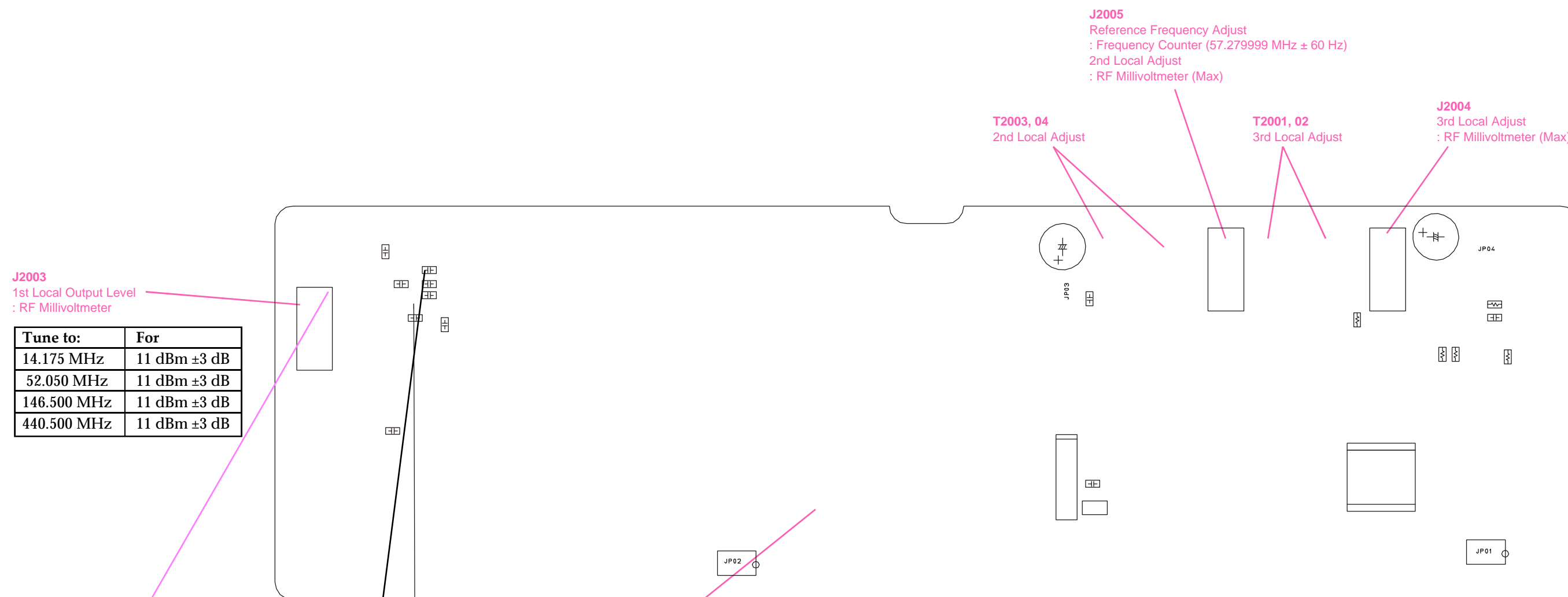

J2003
1st Local Output Level
: RF Millivoltmeter

Tune to:	For
14.175 MHz	11 dBm \pm 3 dB
52.050 MHz	11 dBm \pm 3 dB
146.500 MHz	11 dBm \pm 3 dB
440.500 MHz	11 dBm \pm 3 dB

J2005
Reference Frequency Adjust
: Frequency Counter (57.279999 MHz \pm 60 Hz)
2nd Local Adjust
: RF Millivoltmeter (Max)

T2003, 04
2nd Local Adjust

T2001, 02
3rd Local Adjust

J2004
3rd Local Adjust
: RF Millivoltmeter (Max)

TP2001
VCO VCV Adjust
: DC Voltmeter

Tune to:	Adjust/Confirm	For
449.99999 MHz	Adjust TC2005	7.4 V \pm 0.1 V
420.00000 MHz	Confirm	2.0 V ~ 4.8 V
381.99999 MHz	Adjust TC2006	7.4 V \pm 0.1 V
108.00000 MHz	Confirm	1.2 V ~ 4.0 V
245.99999 MHz	Adjust TC2004	7.4 V \pm 0.1 V
60.00000 MHz	Confirm	0.8 V ~ 4.0 V
197.99999 MHz	Adjust TC2003	7.4 V \pm 0.1 V
33.00000 MHz	Confirm	1.2 V ~ 4.0 V
170.99999 MHz	Adjust TC2002	7.4 V \pm 0.1 V
15.00000 MHz	Confirm	1.4 V ~ 4.2 V
14.99999 MHz	Adjust TC2001	5.0 V \pm 0.1 V
0.03000 MHz	Confirm	0.8 V ~ 4.0 V

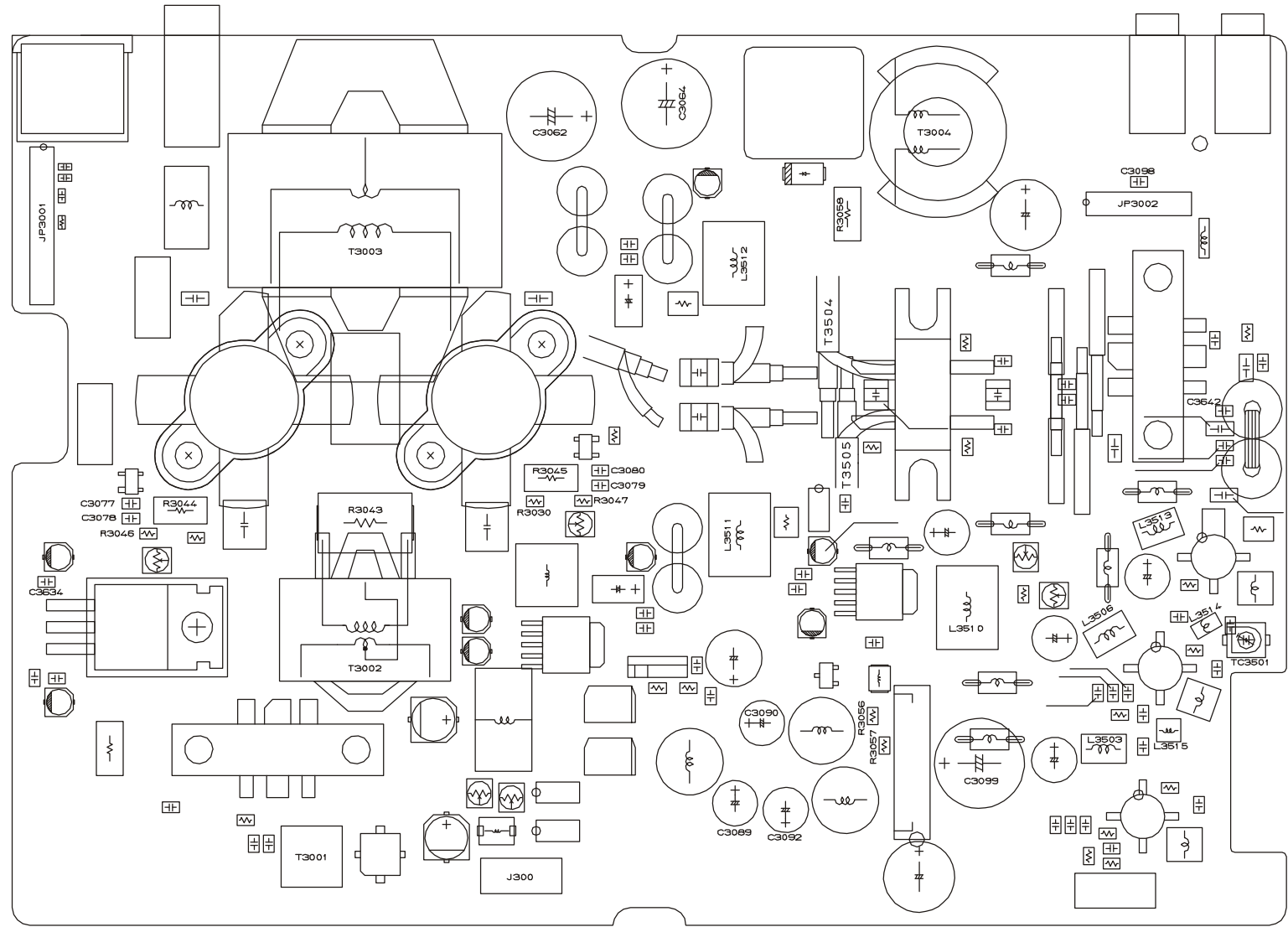

Alignment

LPF-Unit Alignment Points

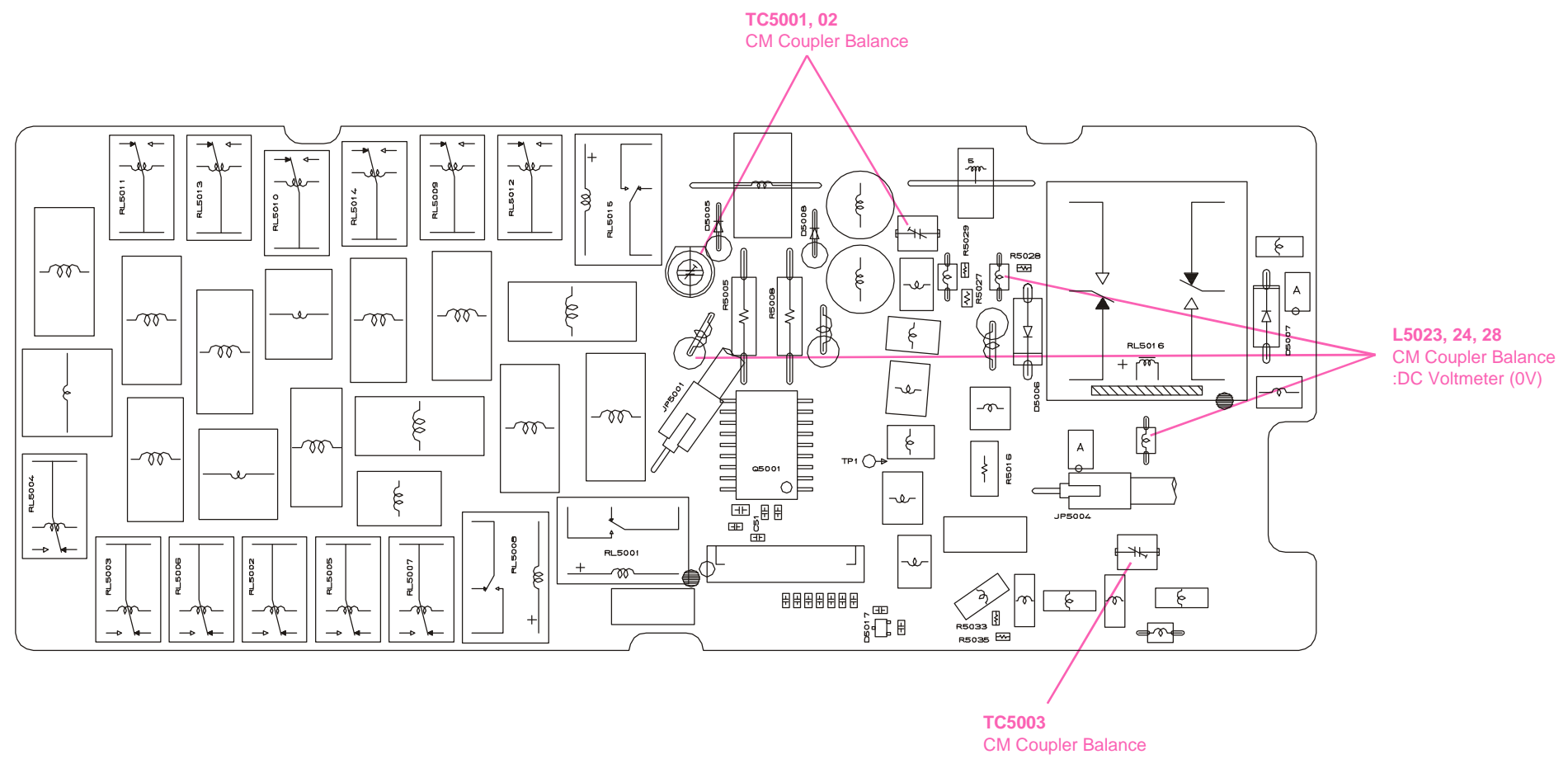



Interconnection Diagram

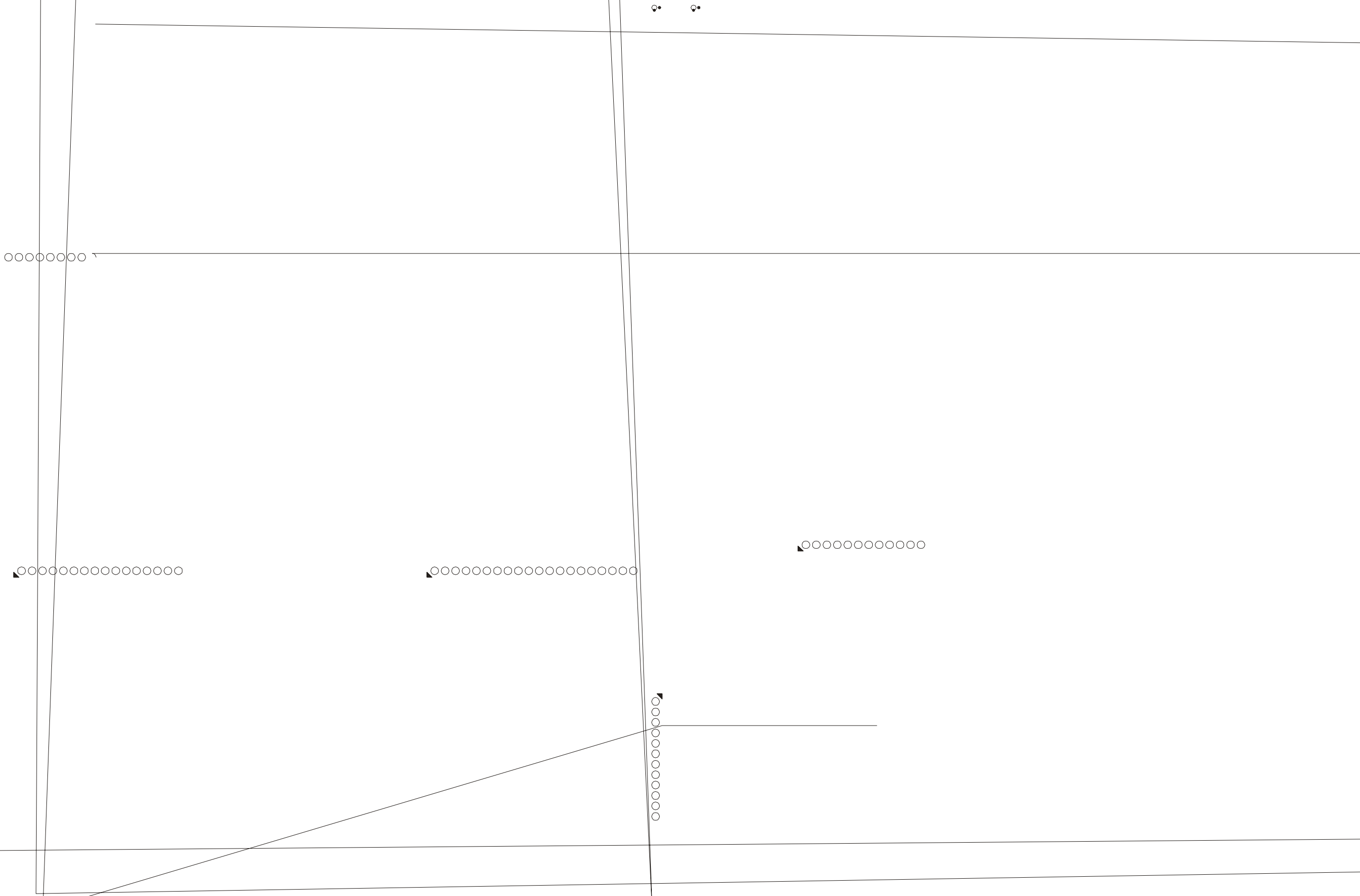

Circuit Diagram

MAIN Unit (Lot. 1~4)

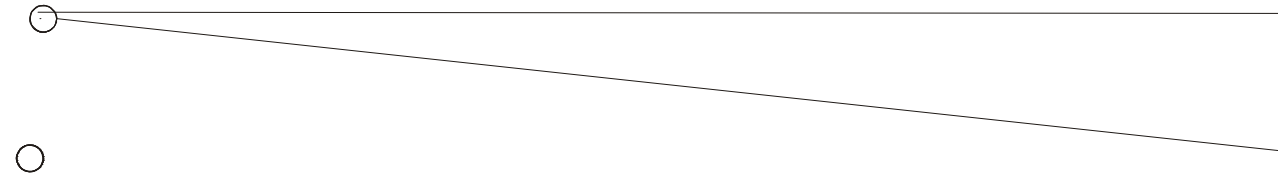
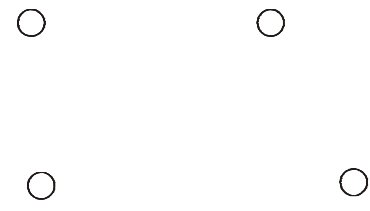

MAIN Unit (Lot. 1~4)

Note:

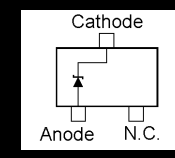
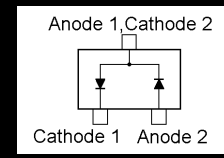
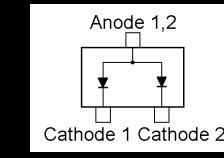
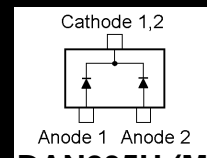
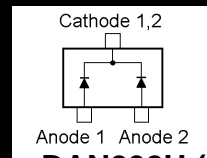
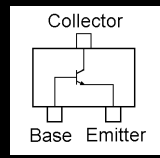
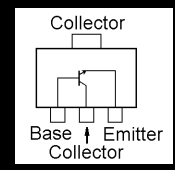
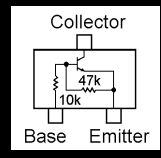
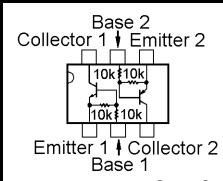
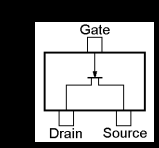
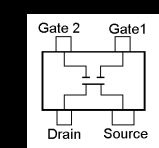
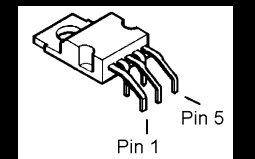
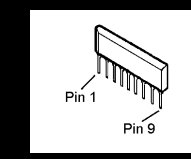
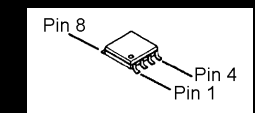
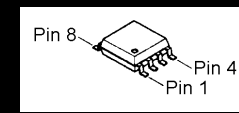
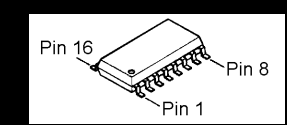
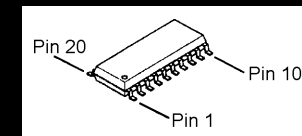
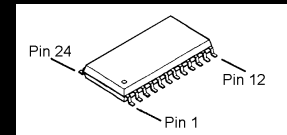
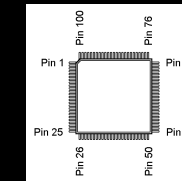
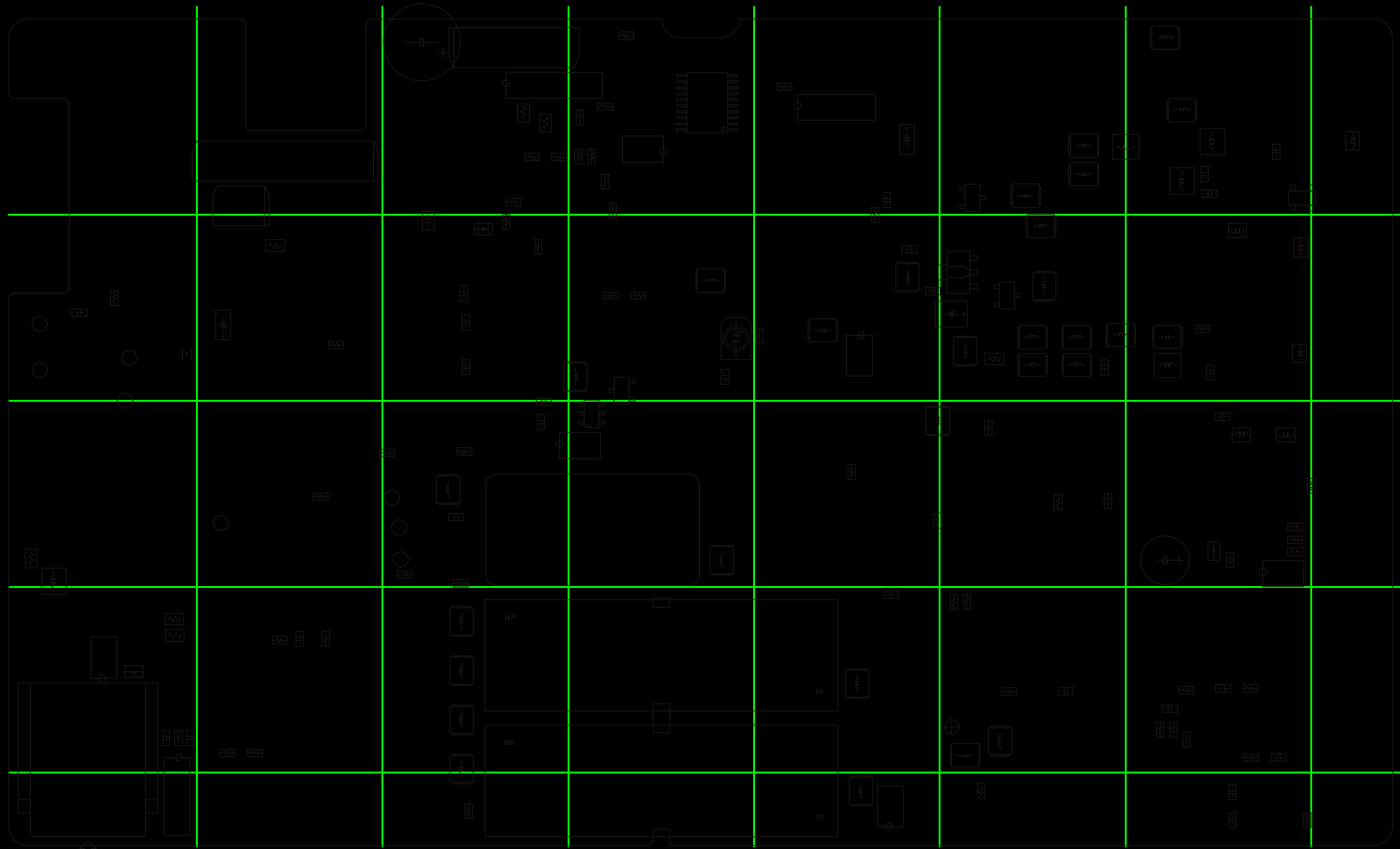

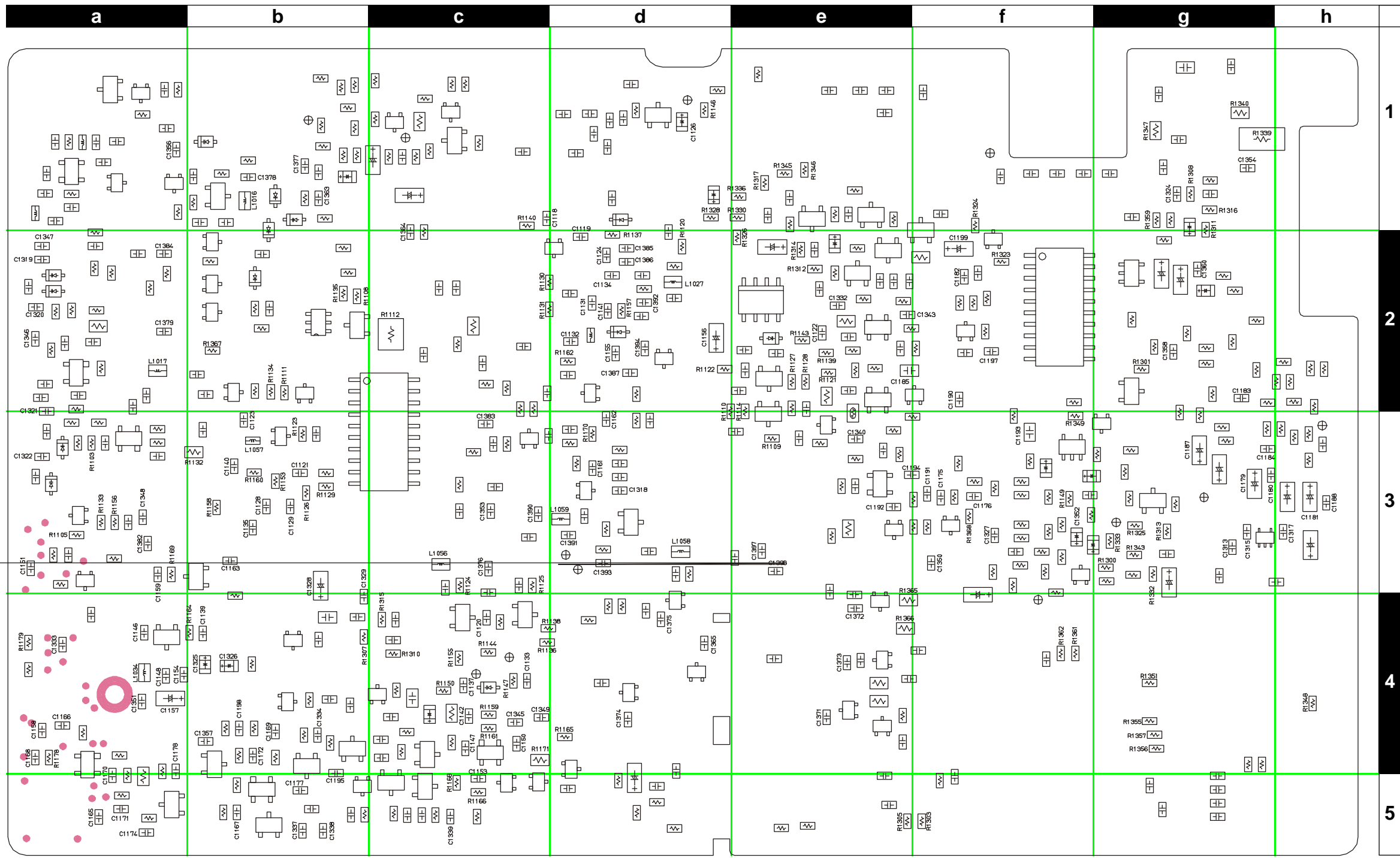

CXP2005M (Lot. 1), NJU3714G (Lot. 2-) (Q1001, 1010) **TC4W53F** (Q1030)

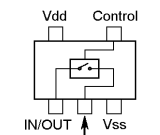

TC4S66F (C9) (Q1044, 1051) **TC7S32FU (E4)** (Q1083)

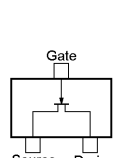

2SK160 (K6) (Q1057, 1061) **SST310 (Z0)** (Q1013)

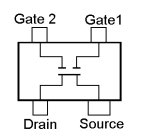

3SK131 (V12) (Q1012, 1031, 1035, 1042, 1045, 1049), **SGM2016M (M-)** (Q1005, 1011)

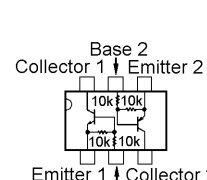

IMD3 (D3) (Q1019)

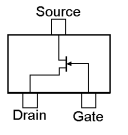

2SK302GR (TG) (Q1037, 1038, 1040), **2SK302Y (TY)** (Q1026, 1027)

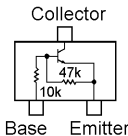

2SC4047 (ZY) (Q1002, 1024, 1034, 1059)

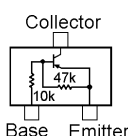

2SA1563B (RL) (Q1048)

Side B

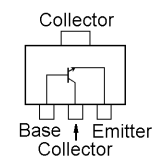

2SC3444 (DE) (Q1072)

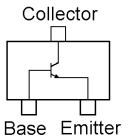

2SC2812 (L6) (Q1007, 1021, 1025, 1046, 1047, 1052, 1053, 1073, 1084), **2SC3356 (R25)** (Q1008)

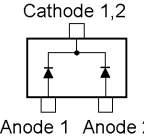

DAN202U (N) (D1002, 1003, 1011, 1048, 1051, 1052, 1059, 1063, 1070, 1072, 1074, 1075, 1096, 1097, 1098, 1099, 1064, 1065, 1066, 1067, 1068, 1069, 1032, 1033, 1034, 1037, 1041, 1043, 1061, 1079)

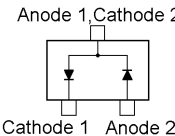

1SS302 (C3)

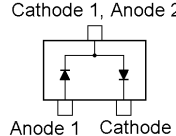

HSM198S (C6) (D1050, 1060, 1062)

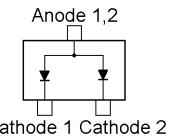

DAP202U (P) (D1065)

MAIN Unit (Lot. 5~)

Note:

MAIN Unit (Lot. 5~)

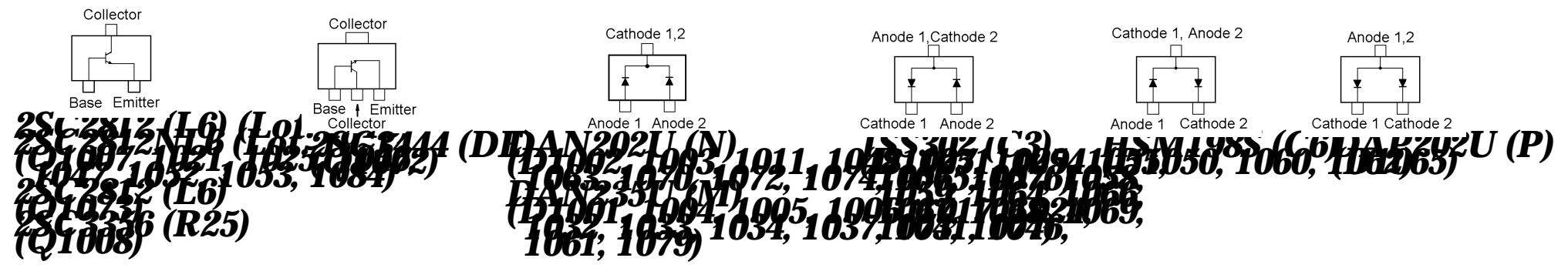
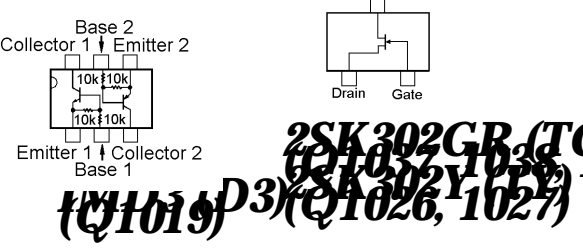
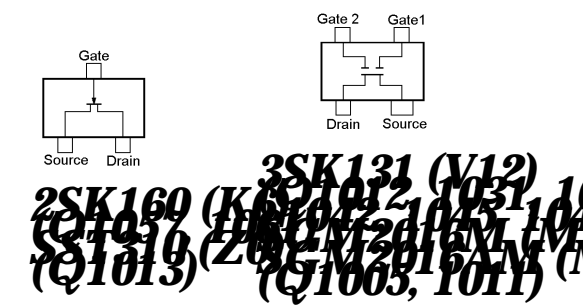
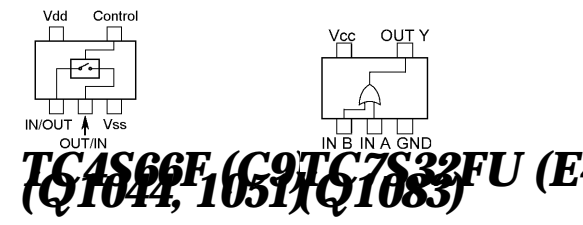
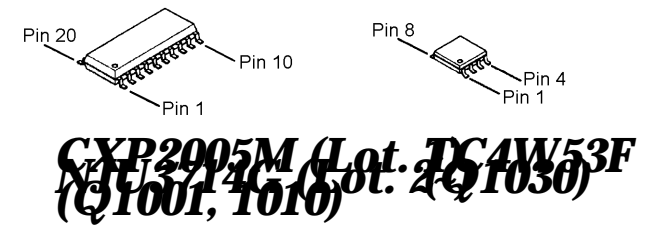
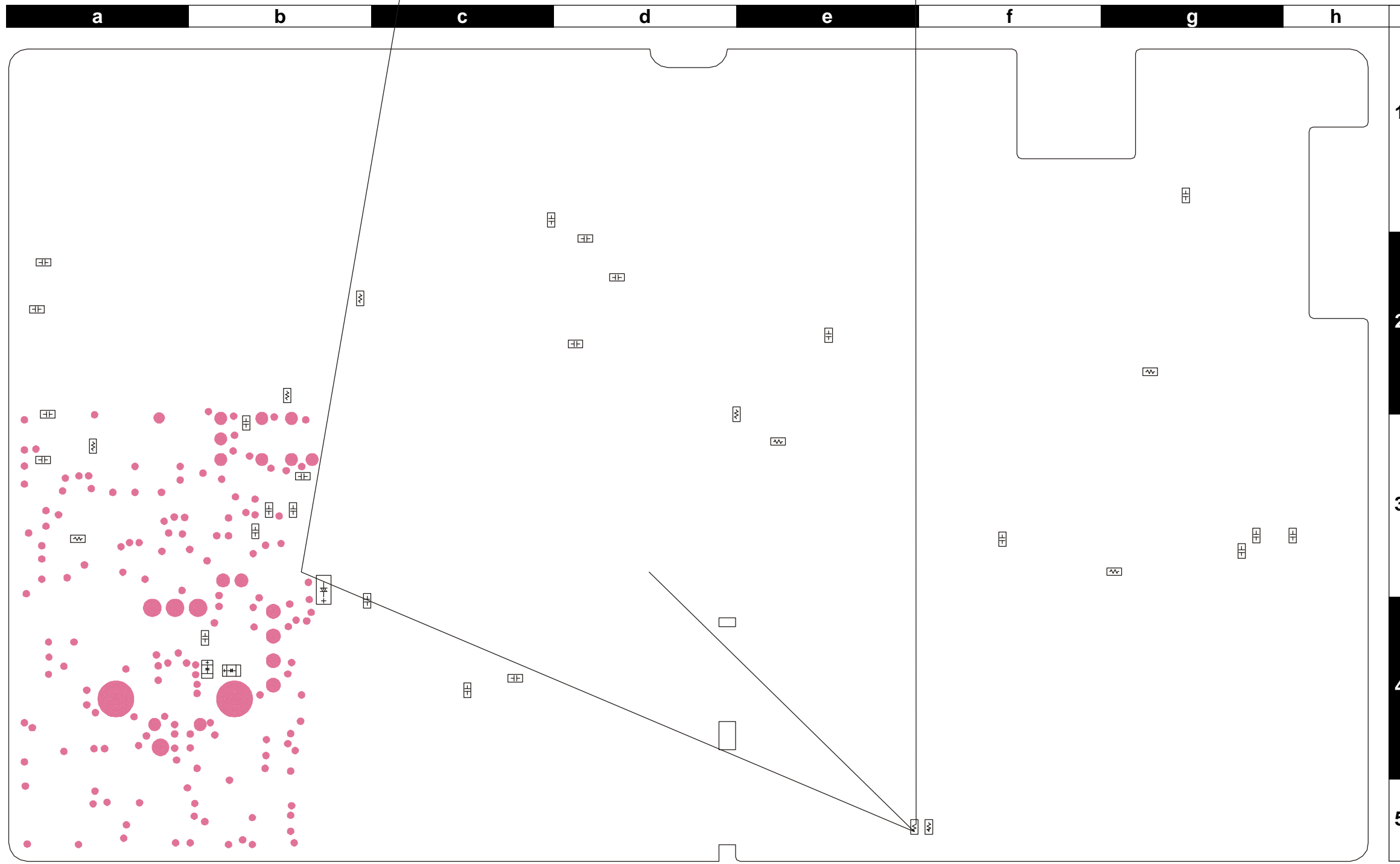

Parts List

REF.	DESCRIPTION	VALUE	V/W		MFR'S DESIG	VXSTD P/N	VERS.	LOT.	SIDE	LAY ADR
*** MAIN-UNIT ***										
	PCB with Components						CP6070003			
	PCB with Components (w/ XF-117C)						CP6070006			
	PCB with Components (w/ XF-117C, XF-117CN)						CP6070008			
	Printed Circuit Board						FR001630E			
	Printed Circuit Board						FR001630F	5-		
C 1001	CHIP CAP.	0.01uF	25V	B	GRM39B103K25PT	K22144803		1-	B	a4
C 1002	CHIP CAP.	0.001uF	50V	B	GRM39B102K50PT	K22174821		1-	B	c2
C 1003	CHIP TA.CAP.	10uF	16V		TEMSVB21C106M-8R	K78120025		1-	A	F2
C 1004	CHIP CAP.	0.01uF	25V	B	GRM39B103K25PT	K22144803		1-	A	E2
C 1005	CHIP CAP.	0.001uF	50V	B	GRM39B102K50PT	K22174821		1		
C 1006	CHIP CAP.	0.047uF	16V	B	GRM39B473K16PT	K22124804		1-	A	E2
C 1007	CHIP CAP.	0.01uF	25V	B	GRM39B103K25PT	K22144803		1-	B	a1
C 1008	CHIP CAP.	0.001uF	50V	B	GRM39B102K50PT	K22174821		1-	A	G1
C 1009	CHIP CAP.	0.001uF	50V	B	GRM39B102K50PT	K22174821		1	A	G1
C 1009	CHIP CAP.	2pF	50V	CK	GRM39CK020C50PT	K22174203		2-	A	G1
C 1010	CHIP CAP.	0.001uF	50V	B	GRM39B102K50PT	K22174821		1	B	a1
C 1010	CHIP CAP.	5pF	50V	CH	GRM39CH050C50PT	K22174206		2-	B	a1
C 1011	CHIP TA.CAP.	0.68uF	10V		TESVSP1A684M-8R	K78100025		1-	B	b1
C 1012	CHIP CAP.	0.001uF	50V	B	GRM39B102K50PT	K22174821		1	A	G1
C 1012	CHIP CAP.	5pF	50V	CH	GRM39CH050C50PT	K22174206		2-	A	G1
C 1013	CHIP CAP.	0.001uF	50V	B	GRM39B102K50PT	K22174821		1-	A	G1
C 1014	CHIP CAP.	0.01uF	25V	B	GRM39B103K25PT	K22144803		1-	A	E3
C 1015	CHIP CAP.	0.001uF	50V	B	GRM39B102K50PT	K22174821		1-	B	a1
C 1016	CHIP CAP.	0.01uF	25V	B	GRM39B103K25PT	K22144803		1-	B	c1
C 1017	CHIP CAP.	0.001uF	50V	B	GRM39B102K50PT	K22174821		1-	B	d3
C 1018	CHIP CAP.	0.001uF	50V	B	GRM39B102K50PT	K22174821		1-	B	c3
C 1019	CHIP CAP.	0.001uF	50V	B	GRM39B102K50PT	K22174821		1-	A	G1
C 1020	CHIP CAP.	100pF	50V	CH	GRM39CH101J50PT	K22174235		1	B	b1
C 1020	CHIP CAP.	22pF	50V	CH	GRM39CH220J50PT	K22174219		2-	B	b1
C 1021	CHIP CAP.	0.001uF	50V	B	GRM39B102K50PT	K22174821		1-	B	a2
C 1022	CHIP CAP.	0.01uF	25V	B	GRM39B103K25PT	K22144803		1-	B	c3
C 1023	CHIP CAP.	0.001uF	50V	B	GRM39B102K50PT	K22174821		1-	B	d2
C 1024	CHIP TA.CAP.	10uF	10V		TEMSVA1A106M-8R	K78100028		1-	B	c1
C 1025	CHIP CAP.	0.001uF	50V	B	GRM39B102K50PT	K22174821		1-	B	a1
C 1026	CHIP CAP.	0.01uF	25V	B	GRM39B103K25PT	K22144803		1-	B	c2
C 1027	CHIP CAP.	0.001uF	50V	B	GRM39B102K50PT	K22174821		1-	A	G2
C 1028	CHIP CAP.	5pF	50V	CH	GRM39CH050C50PT	K22174206		1	B	a1
C 1028	CHIP CAP.	0.001uF	50V	B	GRM39B102K50PT	K22174821		2-	B	a1
C 1029	CHIP CAP.	0.001uF	50V	B	GRM39B102K50PT	K22174821		1-	A	H1
C 1030	CHIP CAP.	3pF	50V	CJ	GRM39CJ030C50PT	K22174204		1	A	G2
C 1030	CHIP CAP.	5pF	50V	CH	GRM39CH050C50PT	K22174206		2-	A	G2
C 1031	CHIP CAP.	0.01uF	25V	B	GRM39B103K25PT	K22144803		1	A	F2
C 1031	CHIP CAP.	0.1uF	16V	B	GRM39B104K16PT	K22124805		2-	A	F2
C 1032	CHIP CAP.	0.047uF	16V	B	GRM39B473K16PT	K22124804		1-	A	F2
C 1033	CHIP CAP.	0.1uF	16V	B	GRM39B104K16PT	K22124805		1-	B	a1
C 1034	CHIP CAP.	0.001uF	50V	B	GRM39B102K50PT	K22174821		1-	A	G2
C 1035	CHIP CAP.	1pF	50V	CK	GRM39CK010C50PT	K22174202		1	B	a1
C 1035	CHIP CAP.	22pF	50V	CH	GRM39CH220J50PT	K22174219		2-	B	a1
C 1036	CHIP CAP.	0.001uF	50V	B	GRM39B102K50PT	K22174821		1-	B	a2
C 1037	CHIP CAP.	0.01uF	25V	B	GRM39B103K25PT	K22144803		1-	A	F2
C 1038	CHIP CAP.	2pF	50V	CK	GRM39CK020C50PT	K22174203		1	B	b1
C 1038	CHIP CAP.	33pF	50V	CH	GRM39CH330J50PT	K22174223		2-	B	b1
C 1039	CHIP CAP.	0.1uF	16V	B	GRM39B104K16PT	K22124805		1-	A	F1
C 1040	CHIP TA.CAP.	10uF	10V		TEMSVA1A106M-8R	K78100028		1-	B	c1
C 1041	CHIP CAP.	0.0068uF	50V	B	GRM39B682M50PT	K22174819		1-	A	F2
C 1042	CHIP CAP.	2pF	50V	CK	GRM39CK020C50PT	K22174203		1	B	b1
C 1042	CHIP CAP.	33pF	50V	CH	GRM39CH330J50PT	K22174223		2-	B	b1
C 1043	CHIP CAP.	0.01uF	25V	B	GRM39B103K25PT	K22144803		1-	A	F1
C 1044	CHIP CAP.	47pF	50V	CH	GRM39CH470J50PT	K22174227		1	A	G1
C 1044	CHIP CAP.	82pF	50V	CH	GRM39CH820J50PT	K22174233		2-	A	G1
C 1046	CHIP CAP.	15pF	50V	CH	GRM39CH150J50PT	K22174215		1	A	G1
C 1046	CHIP CAP.	22pF	50V	CH	GRM39CH220J50PT	K22174219		2-	A	G1
C 1048	CHIP CAP.	82pF	50V	CH	GRM39CH820J50PT	K22174233		1	A	G1
C 1048	CHIP CAP.	100pF	50V	CH	GRM39CH101J50PT	K22174235		2-	A	G1
C 1049	CHIP CAP.	0.001uF	50V	B	GRM39B102K50PT	K22174821		1-	B	a2
C 1050	CHIP CAP.	0.047uF	16V	B	GRM39B473K16PT	K22124804		1-	A	F1
C 1051	CHIP CAP.	0.5pF	50V	CK	GRM39CK0R5C50PT	K22174201		1	B	a2

MAIN Unit

REF.	DESCRIPTION	VALUE	V/W	TOL.	MFR'S DESIG	VXSTD P/N	VERS.	LOT.	SIDE	LAY ADR
C 1051	CHIP CAP.	1pF	50V	CK	GRM39CK010C50PT	K22174202		2-	B	a2
C 1052	CHIP CAP.	33pF	50V	CH	GRM39CH330J50PT	K22174223		1	A	F1
C 1052	CHIP CAP.	82pF	50V	CH	GRM39CH820J50PT	K22174233		2-	A	F1
C 1053	CHIP CAP.	0.01uF	25V	B	GRM39B103K25PT	K22144803		1-	B	c3
C 1054	CHIP CAP.	0.001uF	50V	B	GRM39B102K50PT	K22174821		1-	B	a2
C 1055	CHIP CAP.	56pF	50V	CH	GRM39CH560J50PT	K22174229		1	A	F1
C 1055	CHIP CAP.	68pF	50V	CH	GRM39CH680J50PT	K22174231		2-	A	F1
C 1056	CHIP CAP.	33pF	50V	CH	GRM39CH330J50PT	K22174223		1	A	F1
C 1056	CHIP CAP.	56pF	50V	CH	GRM39CH560J50PT	K22174229		2-	A	F1
C 1058	CHIP CAP.	56pF	50V	CH	GRM39CH560J50PT	K22174229		1	A	F1
C 1058	CHIP CAP.	22pF	50V	CH	GRM39CH220J50PT	K22174219		2-	A	F1
C 1059	CHIP CAP.	82pF	50V	CH	GRM39CH820J50PT	K22174233		1	A	F1
C 1059	CHIP CAP.	100pF	50V	CH	GRM39CH101J50PT	K22174235		2-	A	F1
C 1060	CHIP CAP.	0.001uF	50V	B	GRM39B102K50PT	K22174821		1-	B	d3
C 1061	CHIP CAP.	0.001uF	50V	B	GRM39B102K50PT	K22174821		1-	B	a3
C 1062	CHIP CAP.	15pF	50V	CH	GRM39CH150J50PT	K22174215		1	A	F1
C 1062	CHIP CAP.	68pF	50V	CH	GRM39CH680J50PT	K22174231		2-	A	F1
C 1063	CHIP CAP.	0.1uF	16V	B	GRM39B104K16PT	K22124805		1-	A	F1
C 1064	CHIP CAP.	47pF	50V	CH	GRM39CH470J50PT	K22174227		1	B	b1
C 1064	CHIP CAP.	56pF	50V	CH	GRM39CH560J50PT	K22174229		2-	B	b1
C 1065	CHIP CAP.	0.001uF	50V	B	GRM39B102K50PT	K22174821		1-	B	a2
C 1066	CHIP CAP.	0.001uF	50V	B	GRM39B102K50PT	K22174821		1	B	a2
C 1066	CHIP CAP.	22pF	50V	CH	GRM39CH220J50PT	K22174219		2-	B	a2
C 1067	CHIP CAP.	0.01uF	25V	B	GRM39B103K25PT	K22144803		1-	B	d3
C 1068	CHIP CAP.	0.001uF	50V	B	GRM39B102K50PT	K22174821		1-	A	G3
C 1069	CHIP CAP.	10pF	50V	CH	GRM39CH100D50PT	K22174211		1	A	G3
C 1069	CHIP CAP.	6pF	50V	CH	GRM39CH060D50PT	K22174207		2-	A	G3
C 1070	CHIP CAP.	0.001uF	50V	B	GRM39B102K50PT	K22174821		1-	A	G3
C 1071	CHIP CAP.	0.01uF	25V	B	GRM39B103K25PT	K22144803		1-	B	d3
C 1072	CHIP CAP.	0.001uF	50V	B	GRM39B102K50PT	K22174821		1-	B	a2
C 1073	CHIP CAP.	0.01uF	25V	B	GRM39B103K25PT	K22144803		1-	B	d3
C 1074	CHIP CAP.	3pF	50V	CJ	GRM39CJ030C50PT	K22174204		1	B	a2
C 1074	CHIP CAP.	22pF	50V	CH	GRM39CH220J50PT	K22174219		2-	B	a2
C 1076	CHIP CAP.	0.001uF	50V	B	GRM39B102K50PT	K22174821		1-	A	H2
C 1077	CHIP CAP.	0.0018uF	50V	B	GRM39B182M50PT	K22174812		1-	B	d2
C 1079	CHIP CAP.	5pF	50V	CH	GRM39CH050C50PT	K22174206		1		
C 1080	CHIP CAP.	0.01uF	25V	B	GRM39B103K25PT	K22144803		1		
C 1081	CHIP CAP.	0.047uF	16V	B	GRM39B473K16PT	K22124804		1-	B	b2
C 1084	CHIP CAP.	0.001uF	50V	B	GRM39B102K50PT	K22174821		1		
C 1085	CHIP CAP.	0.5pF	50V	CK	GRM39CK0R5C50PT	K22174201		1	B	a3
C 1085	CHIP CAP.	0.5pF	50V	CK	GRM39CK0R5C50PT	K22174201		2-	B	a3
C 1087	CHIP CAP.	10pF	50V	CH	GRM39CH100C50PT	K22174248		1	B	e3
C 1087	CHIP CAP.	22pF	50V	CH	GRM39CH220J50PT	K22174219		2-	B	e3
C 1088	CHIP CAP.	0.01uF	25V	B	GRM39B103K25PT	K22144803		1-	A	D2
C 1089	CHIP CAP.	0.001uF	50V	B	GRM39B102K50PT	K22174821		1-	B	a3
C 1091	CHIP CAP.	10pF	50V	CH	GRM39CH100C50PT	K22174248		1-	B	e2
C 1092	CHIP CAP.	5pF	50V	CH	GRM39CH050C50PT	K22174206		1	A	E3
C 1092	CHIP CAP.	7pF	50V	CH	GRM39CH070D50PT	K22174208		2-	A	E3
C 1093	CHIP CAP.	5pF	50V	CH	GRM39CH050C50PT	K22174206		1	B	c3
C 1093	CHIP CAP.	1pF	50V	CK	GRM39CK010C50PT	K22174202		2-	B	c3
C 1094	CHIP CAP.	0.001uF	50V	B	GRM39B102K50PT	K22174821		1-	B	a3
C 1095	CHIP CAP.	0.01uF	25V	B	GRM39B103K25PT	K22144803		1-	A	F2
C 1096	CHIP CAP.	0.0018uF	50V	B	GRM39B182M50PT	K22174812		1-	B	d2
C 1098	CHIP CAP.	0.01uF	25V	B	GRM39B103K25PT	K22144803		1-	B	e3
C 1099	CHIP CAP.	0.001uF	50V	B	GRM39B102K50PT	K22174821		1-	A	G3
C 1100	CHIP CAP.	10pF	50V	CH	GRM39CH100C50PT	K22174248		1-	B	e2
C 1101	CHIP CAP.	0.0018uF	50V	B	GRM39B182M50PT	K22174812		1-	B	d2
C 1102	CHIP CAP.	0.01uF	25V	B	GRM39B103K25PT	K22144803		1-	B	e2
C 1103	CHIP CAP.	15pF	50V	CH	GRM39CH150J50PT	K22174215		1	B	c4
C 1103	CHIP CAP.	7pF	50V	CH	GRM39CH070D50PT	K22174208		2-	B	c4
C 1104	CHIP CAP.	0.01uF	25V	B	GRM39B103K25PT	K22144803		1-	A	F2
C 1106	CHIP CAP.	100pF	50V	CH	GRM39CH101J50PT	K22174235		1-	B	e2
C 1108	CHIP CAP.	0.047uF	16V	B	GRM39B473K16PT	K22124804		1-	B	b2
C 1109	CHIP CAP.	0.01uF	25V	B	GRM39B103K25PT	K22144803		1-	A	E4
C 1110	CHIP CAP.	0.01uF	25V	B	GRM39B103K25PT	K22144803		1-	B	b3
C 1111	CHIP CAP.	180pF	50V	CH	GRM39CH181J50PT	K22174241		1	B	e2
C 1111	CHIP CAP.	22pF	50V	CH	GRM39CH220J50PT	K22174219		2-	B	e2
C 1112	CHIP CAP.	0.001uF	50V	B	GRM39B102K50PT	K22174821		1-	B	a3

REF.	DESCRIPTION	VALUE	V/W	TOL.	MFR'S DESIG	VXSTD P/N	VERS.	LOT.	SIDE	LAY ADR
C 1113	CHIP CAP.	0.01uF	25V	B	GRM39B103K25PT	K22144803		1-	B	c3
C 1114	CHIP CAP.	0.01uF	25V	B	GRM39B103K25PT	K22144803		1-	B	c3
C 1115	CHIP CAP.	1pF	50V	CK	GRM39CK010C50PT	K22174202		1-1	A	G3
C 1115	CHIP CAP.	10pF	50V	CH	GRM39CH100D50PT	K22174211		3	A	G3
C 1116	CHIP CAP.	0.001uF	50V	B	GRM39B102K50PT	K22174821		1-	B	d2
C 1117	CHIP CAP.	0.01uF	25V	B	GRM39B103K25PT	K22144803		1-	B	b3
C 1118	CHIP CAP.	0.001uF	50V	B	GRM39B102K50PT	K22174821		1-	B	c1
C 1118	CHIP CAP.	33pF	50V	CH	GRM39CH330J50PT	K22174223		4-	B	c1
C 1119	CHIP CAP.	0.001uF	50V	B	GRM39B102K50PT	K22174821		1-	B	d2
C 1120	CHIP CAP.	0.01uF	25V	B	GRM39B103K25PT	K22144803		1	B	c4
C 1120	CHIP CAP.	0.1uF	16V	B	GRM39B104K16PT	K22124805		2-	B	c4
C 1121	CHIP CAP.	0.01uF	25V	B	GRM39B103K25PT	K22144803		1	B	b3
C 1121	CHIP CAP.	0.047uF	16V	B	GRM39B473K16PT	K22124804		2-	B	b3
C 1122	CHIP CAP.	0.01uF	25V	B	GRM39B103K25PT	K22144803		1-	B	e2
C 1123	CHIP CAP.	0.01uF	25V	B	GRM39B103K25PT	K22144803		1-	B	b3
C 1124	CHIP CAP.	47pF	50V	CH	GRM39CH470J50PT	K22174227		1	B	d2
C 1124	CHIP CAP.	22pF	50V	UJ	GRM39UJ220J50PT	K22174316		2-	B	d2
C 1125	CHIP CAP.	1pF	50V	CK	GRM39CK010C50PT	K22174202		1	A	H3
C 1126	CHIP TA.CAP.	10uF	10V		TEMSVA1A106M-8R	K78100028		1	B	d1
C 1126	CHIP TA.CAP.	10uF	6.3V		TESVSP0J106M-8R	K78080055		2-	B	d1
C 1127	CHIP CAP.	0.001uF	50V	B	GRM39B102K50PT	K22174821		1-	A	E1
C 1128	CHIP CAP.	0.01uF	25V	B	GRM39B103K25PT	K22144803		1-	B	b3
C 1129	CHIP CAP.	0.01uF	25V	B	GRM39B103K25PT	K22144803		1-	B	b3
C 1130	CHIP CAP.	0.01uF	25V	B	GRM39B103K25PT	K22144803		1-	A	D2
C 1131	CHIP CAP.	0.001uF	50V	B	GRM39B102K50PT	K22174821		1	B	d2
C 1131	CHIP CAP.	18pF	50V	CH	GRM39CH180J50PT	K22174217		2-	B	d2
C 1132	CHIP CAP.	0.001uF	50V	B	GRM39B102K50PT	K22174821		1-	B	d2
C 1133	CHIP CAP.	0.01uF	25V	B	GRM39B103K25PT	K22144803		1-	B	c4
C 1134	CHIP CAP.	0.5pF	50V	CK	GRM39CK0R5C50PT	K22174201		1	B	d2
C 1134	CHIP CAP.	0.5pF	50V	CK	GRM39CK0R5C50PT	K22174201		2-	B	d2
C 1135	CHIP CAP.	0.01uF	25V	B	GRM39B103K25PT	K22144803		1-	B	b3
C 1136	CHIP CAP.	15pF	50V	CH	GRM39CH150J50PT	K22174215		1	A	F3
C 1136	CHIP CAP.	8pF	50V	UJ	GRM39UJ080D50PT	K22174308		2-	A	F3
C 1137	CHIP CAP.	0.01uF	25V	B	GRM39B103K25PT	K22144803		1-	B	c4
C 1138	CHIP CAP.	0.001uF	50V	B	GRM39B102K50PT	K22174821		1-	A	G3
C 1139	CHIP CAP.	0.01uF	25V	B	GRM39B103K25PT	K22144803		1-	B	b4
C 1140	CHIP CAP.	0.01uF	25V	B	GRM39B103K25PT	K22144803		1-	B	b3
C 1141	CHIP CAP.	47pF	50V	CH	GRM39CH470J50PT	K22174227		1	B	d2
C 1141	CHIP CAP.	22pF	50V	UJ	GRM39UJ220J50PT	K22174316		2-	B	d2
C 1142	CHIP CAP.	0.01uF	25V	B	GRM39B103K25PT	K22144803		1-	B	c4
C 1143	CHIP CAP.	100pF	50V	CH	GRM39CH101J50PT	K22174235		1-	A	G3
C 1144	CHIP CAP.	10pF	50V	CH	GRM39CH100D50PT	K22174211		1		
C 1145	CHIP CAP.	47pF	50V	CH	GRM39CH470J50PT	K22174227		1		
C 1146	CHIP CAP.	0.01uF	25V	B	GRM39B103K25PT	K22144803		1-	B	a4
C 1147	CHIP CAP.	0.01uF	25V	B	GRM39B103K25PT	K22144803		1-	B	c4
C 1148	CHIP CAP.	10pF	50V	CH	GRM39CH100D50PT	K22174211		1	B	a4
C 1148	CHIP CAP.	3pF	50V	CJ	GRM39CJ030C50PT	K22174204		2	B	a4
C 1148	CHIP CAP.	4pF	50V	CH	GRM39CH040C50PT	K22174205		3-	B	a4
C 1149	CHIP CAP.	100pF	50V	CH	GRM39CH101J50PT	K22174235		1	A	G3
C 1149	CHIP CAP.	220pF	50V	CH	GRM39CH221J50PT	K22174243		2-	A	G3
C 1150	CHIP CAP.	0.01uF	25V	B	GRM39B103K25PT	K22144803		1-	B	c4
C 1151	CHIP CAP.	9pF	50V	CH	GRM39CH090D50PT	K22174210		1	B	a3
C 1151	CHIP CAP.	10pF	50V	UJ	GRM39UJ100D50PT	K22174301		2-	B	a3
C 1152	CHIP CAP.	100pF	50V	CH	GRM39CH101J50PT	K22174235		1-	A	G4
C 1153	CHIP CAP.	0.01uF	25V	B	GRM39B103K25PT	K22144803		1-	B	c5
C 1154	CHIP CAP.	0.01uF	25V	B	GRM39B103K25PT	K22144803		1-	B	a4
C 1155	CHIP CAP.	0.5pF	50V	CK	GRM39CK0R5C50PT	K22174201		1	B	d2
C 1155	CHIP CAP.	3pF	50V	CJ	GRM39CJ030C50PT	K22174204		2-	B	d2
C 1156	CHIP TA.CAP.	10uF	10V		TEMSVA1A106M-8R	K78100028		1-	B	d2
C 1157	CHIP TA.CAP.	10uF	10V		TEMSVA1A106M-8R	K78100028		1-	B	a4
C 1158	CHIP CAP.	15pF	50V	CH	GRM39CH150J50PT	K22174215		1	B	a4
C 1158	CHIP CAP.	4pF	50V	UJ	GRM39UJ040C50PT	K22174304		2-	B	a4
C 1159	CHIP CAP.	0.01uF	25V	B	GRM39B103K25PT	K22144803		1-	B	a3
C 1160	AL.ELECTRO.CAP.	47uF	16V		RE2-16V470M 47UF	K40129054		1-	A	G3
C 1161	CHIP CAP.	0.001uF	50V	B	GRM39B102K50PT	K22174821		1-	B	d3
C 1162	CHIP CAP.	0.001uF	50V	B	GRM39B102K50PT	K22174821		1-	B	d3
C 1163	CHIP CAP.	0.01uF	25V	B	GRM39B103K25PT	K22144803		1-	B	b3
C 1164	CHIP CAP.	47pF	50V	CH	GRM39CH470J50PT	K22174227		1		

MAIN Unit

REF.	DESCRIPTION	VALUE	V/W	TOL.	MFR'S DESIG	VXSTD P/N	VERS.	LOT.	SIDE	LAY ADR
C 1165	CHIP CAP.	0.01uF	25V	B	GRM39B103K25PT	K22144803		1-	B	a5
C 1165	CHIP CAP.	0.1uF	16V	B	GRM39B104K16PT	K22124805		4-	B	a5
C 1166	CHIP CAP.	47pF	50V	CH	GRM39CH470J50PT	K22174227		1	B	a4
C 1166	CHIP CAP.	33pF	50V	CH	GRM39CH330J50PT	K22174223		2-	B	a4
C 1167	CHIP CAP.	100pF	50V	CH	GRM39CH101J50PT	K22174235		1-	B	b5
C 1168	CHIP CAP.	0.01uF	25V	B	GRM39B103K25PT	K22144803		1-	B	a4
C 1169	CHIP CAP.	0.01uF	25V	B	GRM39B103K25PT	K22144803		1-	B	b4
C 1170	CHIP CAP.	0.01uF	25V	B	GRM39B103K25PT	K22144803		1-	B	a5
C 1171	CHIP CAP.	15pF	50V	CH	GRM39CH150J50PT	K22174215		1	B	a5
C 1171	CHIP CAP.	8pF	50V	UJ	GRM39UJ080D50PT	K22174308		2-	B	a5
C 1172	CHIP CAP.	0.01uF	25V	B	GRM39B103K25PT	K22144803		1-	B	b4
C 1173	CHIP CAP.	0.01uF	25V	B	GRM39B103K25PT	K22144803		1-	A	G4
C 1174	CHIP CAP.	0.001uF	50V	B	GRM39B102K50PT	K22174821		1-	B	a5
C 1175	CHIP CAP.	0.01uF	25V	B	GRM39B103K25PT	K22144803		1-	B	f3
C 1176	CHIP CAP.	0.01uF	25V	B	GRM39B103K25PT	K22144803		1-	B	f3
C 1177	CHIP CAP.	0.01uF	25V	B	GRM39B103K25PT	K22144803		1-	B	b5
C 1178	CHIP CAP.	0.01uF	25V	B	GRM39B103K25PT	K22144803		1-	B	a4
C 1179	CHIP TA.CAP.	10uF	10V		TEMSVA1A106M-8R	K78100028		1-	B	g3
C 1180	CHIP CAP.	0.1uF	16V	B	GRM39B104K16PT	K22124805		1-	B	g3
C 1181	CHIP TA.CAP.	10uF	10V		TEMSVA1A106M-8R	K78100028		1-	B	h3
C 1182	CHIP CAP.	0.01uF	25V	B	GRM39B103K25PT	K22144803		1-	B	f2
C 1183	CHIP CAP.	0.0015uF	50V	B	GRM39B152M50PT	K22174811		1-	B	g2
C 1184	CHIP CAP.	0.0015uF	50V	B	GRM39B152M50PT	K22174811		1-	B	g3
C 1185	CHIP TA.CAP.	10uF	10V		TEMSVA1A106M-8R	K78100028		1	B	e2
C 1185	CHIP CAP.	0.33uF	16V	B	GRM40B334K16PT	K22120807		2-	B	e2
C 1186	CHIP CAP.	0.01uF	25V	B	GRM39B103K25PT	K22144803		1-	A	F4
C 1187	CHIP TA.CAP.	10uF	10V		TEMSVA1A106M-8R	K78100028		1-	B	g3
C 1188	CHIP CAP.	0.1uF	16V	B	GRM39B104K16PT	K22124805		1-	B	h3
C 1189	CHIP TA.CAP.	10uF	10V		TEMSVA1A106M-8R	K78100028		1	A	C3
C 1189	AL.ELECTRO.CAP.	100uF	10V		RE2-10V101M 100UF	K40109024		2-	A	C3
C 1190	CHIP CAP.	0.01uF	25V	B	GRM39B103K25PT	K22144803		1-	B	f2
C 1191	CHIP CAP.	0.01uF	25V	B	GRM39B103K25PT	K22144803		1-	B	f3
C 1192	CHIP CAP.	0.01uF	25V	B	GRM39B103K25PT	K22144803		1-	B	e3
C 1193	CHIP TA.CAP.	1uF	10V		TESVSP1A105M-8R	K78100032		1	B	f3
C 1193	CHIP CAP.	1uF	10V	B	GRM40B105K10PT	K22100802		2-	B	f3
C 1194	CHIP CAP.	0.01uF	25V	B	GRM39B103K25PT	K22144803		1-	B	e3
C 1195	CHIP CAP.	22pF	50V	CH	GRM39CH220J50PT	K22174219		1-	B	b4
C 1196	CHIP CAP.	0.01uF	25V	B	GRM39B103K25PT	K22144803		1-	A	C2
C 1197	CHIP CAP.	0.01uF	25V	B	GRM39B103K25PT	K22144803		1-	B	f2
C 1198	CHIP CAP.	0.01uF	25V	B	GRM39B103K25PT	K22144803		1-	B	b4
C 1199	CHIP TA.CAP.	10uF	10V		TEMSVA1A106M-8R	K78100028		1-	B	f2
C 1200	CHIP CAP.	10pF	50V	CH	GRM39CH100D50PT	K22174211		1	B	b5
C 1200	CHIP CAP.	12pF	50V	CH	GRM39CH120J50PT	K22174213		2-	B	b5
C 1201	CHIP CAP.	0.01uF	25V	B	GRM39B103K25PT	K22144803		1-	B	e3
C 1202	CHIP CAP.	0.01uF	25V	B	GRM39B103K25PT	K22144803		1-	B	f2
C 1203	CHIP CAP.	0.01uF	25V	B	GRM39B103K25PT	K22144803		1-	B	f2
C 1204	CHIP TA.CAP.	1uF	10V		TESVSP1A105M-8R	K78100032		1-	A	C2
C 1205	CHIP CAP.	220pF	50V	CH	GRM39CH221J50PT	K22174243		1-	B	c4
C 1206	CHIP CAP.	0.01uF	25V	B	GRM39B103K25PT	K22144803		1-	A	C3
C 1207	CHIP CAP.	0.01uF	25V	B	GRM39B103K25PT	K22144803		1-	B	b5
C 1208	CHIP TA.CAP.	10uF	10V		TEMSVA1A106M-8R	K78100028		1-	B	g3
C 1209	CHIP CAP.	220pF	50V	CH	GRM39CH221J50PT	K22174243		1-	B	c4
C 1210	CHIP CAP.	0.01uF	25V	B	GRM39B103K25PT	K22144803		1-	A	C3
C 1211	CHIP CAP.	0.01uF	25V	B	GRM39B103K25PT	K22144803		1-	B	e3
C 1212	CHIP TA.CAP.	1uF	10V		TESVSP1A105M-8R	K78100032		1-	B	c4
C 1213	CHIP CAP.	0.01uF	25V	B	GRM39B103K25PT	K22144803		1-	A	F5
C 1214	CHIP TA.CAP.	1uF	10V		TESVSP1A105M-8R	K78100032		1-	A	A2
C 1215	CHIP TA.CAP.	1uF	10V		TESVSP1A105M-8R	K78100032		1		
C 1216	CHIP CAP.	0.01uF	25V	B	GRM39B103K25PT	K22144803		1-	B	c5
C 1217	CHIP CAP.	0.01uF	25V	B	GRM39B103K25PT	K22144803		1-	B	e2
C 1218	CHIP TA.CAP.	10uF	10V		TEMSVA1A106M-8R	K78100028		1-	B	d5
C 1219	CHIP CAP.	0.01uF	25V	B	GRM39B103K25PT	K22144803		1		
C 1220	CHIP CAP.	0.01uF	25V	B	GRM39B103K25PT	K22144803		1-	B	h3
C 1221	CHIP CAP.	0.01uF	25V	B	GRM39B103K25PT	K22144803		1-	A	C2
C 1222	CHIP TA.CAP.	10uF	10V		TEMSVA1A106M-8R	K78100028		1		
C 1223	CHIP TA.CAP.	10uF	10V		TEMSVA1A106M-8R	K78100028		1-	B	h3
C 1224	CHIP CAP.	0.01uF	25V	B	GRM39B103K25PT	K22144803		1-	A	E5
C 1225	CHIP CAP.	0.01uF	25V	B	GRM39B103K25PT	K22144803		1-	A	C2

REF.	DESCRIPTION	VALUE	V/W	TOL.	MFR'S DESIG	VXSTD P/N	VERS.	LOT.	SIDE	LAY ADR
C 1226	CHIP TA.CAP.	1uF	10V		TESVSP1A105M-8R	K78100032		1	B	f3
C 1226	CHIP TA.CAP.	10uF	6.3V		TESVSP0J106M-8R	K78080055		2-	B	f3
C 1227	CHIP CAP.	0.01uF	25V	B	GRM39B103K25PT	K22144803		1-	B	e2
C 1228	CHIP CAP.	0.0068uF	50V	B	GRM39B682M50PT	K22174819		1-	B	f3
C 1229	CHIP CAP.	0.01uF	25V	B	GRM39B103K25PT	K22144803		1-	B	e2
C 1230	CHIP TA.CAP.	10uF	10V		TEMSVA1A106M-8R	K78100028		1-	B	h3
C 1231	CHIP TA.CAP.	1uF	10V		TESVSP1A105M-8R	K78100032		1		
C 1232	CHIP CAP.	10pF	50V	CH	GRM39CH100C50PT	K22174248		1	B	h3
C 1232	CHIP CAP.	33pF	50V	CH	GRM39CH330J50PT	K22174223		2-	B	h3
C 1232	CHIP CAP.	18pF	50V	CH	GRM39CH180J50PT	K22174217		34-	B	h3
C 1233	CHIP CAP.	10pF	50V	CH	GRM39CH100C50PT	K22174248		1	B	g3
C 1233	CHIP CAP.	33pF	50V	CH	GRM39CH330J50PT	K22174223		2-	B	g3
C 1233	CHIP CAP.	18pF	50V	CH	GRM39CH180J50PT	K22174217		34-	B	g3
C 1237	CHIP TA.CAP.	1uF	10V		TESVSP1A105M-8R	K78100032		1		
C 1238	CHIP CAP.	10pF	50V	CH	GRM39CH100D50PT	K22174211		1-	B	e2
C 1239	CHIP CAP.	0.01uF	25V	B	GRM39B103K25PT	K22144803		1	A	C2
C 1239	CHIP CAP.	0.1uF	16V	B	GRM39B104K16PT	K22124805		2-	A	C2
C 1240	CHIP TA.CAP.	1uF	10V		TESVSP1A105M-8R	K78100032		1-	A	A2
C 1241	CHIP CAP.	0.01uF	25V	B	GRM39B103K25PT	K22144803		1-	B	d4
C 1242	CHIP CAP.	0.01uF	25V	B	GRM39B103K25PT	K22144803		1-	B	d5
C 1243	CHIP CAP.	0.01uF	25V	B	GRM39B103K25PT	K22144803		1-	A	E4
C 1244	CHIP CAP.	0.01uF	25V	B	GRM39B103K25PT	K22144803		1-	B	d3
C 1245	CHIP CAP.	0.01uF	25V	B	GRM39B103K25PT	K22144803		1-	B	d5
C 1246	CHIP CAP.	0.01uF	25V	B	GRM39B103K25PT	K22144803		1-	B	d4
C 1247	CHIP CAP.	0.0047uF	50V	B	GRM39B472M50PT	K22174817		1-	B	f1
C 1248	CHIP CAP.	0.01uF	25V	B	GRM39B103K25PT	K22144803		1-	B	e4
C 1249	CHIP CAP.	10pF	50V	CH	GRM39CH100D50PT	K22174211		1-	B	e2
C 1250	CHIP TA.CAP.	1uF	10V		TESVSP1A105M-8R	K78100032		1	A	B3
C 1250	CHIP TA.CAP.	10uF	6.3V		TESVSP0J106M-8R	K78080055		2-	A	B3
C 1251	CHIP CAP.	0.1uF	16V	B	GRM39B104K16PT	K22124805		1	B	c4
C 1251	CHIP CAP.	0.33uF	16V	B	GRM40B334K16PT	K22120807		2-	B	c4
C 1252	CHIP CAP.	0.01uF	25V	B	GRM39B103K25PT	K22144803		1-	B	e2
C 1253	CHIP TA.CAP.	1uF	10V		TESVSP1A105M-8R	K78100032		1-	B	f3
C 1254	CHIP CAP.	100pF	50V	CH	GRM39CH101J50PT	K22174235		1-	B	e2
C 1255	CHIP CAP.	0.001uF	50V	B	GRM39B102K50PT	K22174821		1-	B	c4
C 1256	CHIP CAP.	0.0047uF	50V	B	GRM39B472M50PT	K22174817		1-	A	C3
C 1257	CHIP CAP.	0.0047uF	50V	B	GRM39B472M50PT	K22174817		1-	B	f3
C 1258	CHIP TA.CAP.	1uF	10V		TESVSP1A105M-8R	K78100032		1	B	g2
C 1258	CHIP TA.CAP.	10uF	6.3V		TESVSP0J106M-8R	K78080055		2-	B	g2
C 1259	CHIP CAP.	220pF	50V	CH	GRM39CH221J50PT	K22174243		1-	B	e1
C 1260	CHIP TA.CAP.	10uF	10V		TEMSVA1A106M-8R	K78100028		1-	B	f4
C 1261	CHIP CAP.	0.01uF	25V	B	GRM39B103K25PT	K22144803		1-	B	b4
C 1262	CHIP CAP.	68pF	50V	CH	GRM40CH680J50PT	K22170231		1-	B	b4
C 1263	CHIP CAP.	0.01uF	25V	B	GRM39B103K25PT	K22144803		1-	B	e4
C 1264	CHIP CAP.	0.01uF	25V	B	GRM39B103K25PT	K22144803		1-	B	e5
C 1265	CHIP CAP.	0.01uF	25V	B	GRM39B103K25PT	K22144803		1-	B	e4
C 1267	CHIP CAP.	330pF	50V	CH	GRM39CH331J50PT	K22174253		1-	B	b4
C 1268	CHIP TA.CAP.	1uF	10V		TESVSP1A105M-8R	K78100032		1		
C 1269	CHIP CAP.	0.01uF	25V	B	GRM39B103K25PT	K22144803		1-	B	f4
C 1270	CHIP CAP.	0.01uF	25V	B	GRM39B103K25PT	K22144803		1-	B	e5
C 1271	CHIP CAP.	0.01uF	25V	B	GRM39B103K25PT	K22144803		1-	B	e4
C 1272	CHIP TA.CAP.	1uF	10V		TESVSP1A105M-8R	K78100032		1-	B	f3
C 1273	CHIP CAP.	0.1uF	16V	B	GRM39B104K16PT	K22124805		1-	B	b4
C 1274	CHIP TA.CAP.	1uF	10V		TESVSP1A105M-8R	K78100032		1-	B	e2
C 1275	CHIP CAP.	0.1uF	16V	B	GRM39B104K16PT	K22124805		1-	B	c4
C 1276	CHIP TA.CAP.	1uF	10V		TESVSP1A105M-8R	K78100032		1-	B	g1
C 1277	CHIP TA.CAP.	10uF	10V		TEMSVA1A106M-8R	K78100028		1-	B	g2
C 1278	CHIP TA.CAP.	10uF	10V		TEMSVA1A106M-8R	K78100028		1-	B	g2
C 1279	CHIP CAP.	0.047uF	16V	B	GRM39B473K16PT	K22124804		1-	B	e2
C 1280	CHIP CAP.	0.1uF	16V	B	GRM39B104K16PT	K22124805		1-	B	b4
C 1281	CHIP CAP.	100pF	50V	CH	GRM39CH101J50PT	K22174235		1-	B	c4
C 1282	CHIP CAP.	470pF	50V	CH	GRM39CH471J50PT	K22174249		1-	A	F4
C 1283	CHIP CAP.	470pF	50V	CH	GRM39CH471J50PT	K22174249		1-	A	F4
C 1287	CHIP TA.CAP.	1uF	10V		TESVSP1A105M-8R	K78100032		1	A	D1
C 1287	CHIP CAP.	1uF	10V	B	GRM40B105K10PT	K22100802		2-	A	D1
C 1288	CHIP TA.CAP.	1uF	10V		TESVSP1A105M-8R	K78100032		1	B	g1
C 1288	CHIP CAP.	1uF	10V	B	GRM40B105K10PT	K22100802		2-	B	g1
C 1289	CHIP CAP.	0.0022uF	50V	B	GRM39B222M50PT	K22174813		1-	A	C1

MAIN Unit

REF.	DESCRIPTION	VALUE	V/W	TOL.	MFR'S DESIG	VXSTD P/N	VERS.	LOT.	SIDE	LAY ADR
C 1290	CHIP CAP.	0.0033uF	50V	B	GRM39B332M50PT	K22174815		1	B	g1
C 1290	CHIP CAP.	0.0047uF	50V	B	GRM39B472M50PT	K22174817		2-	B	g1
C 1291	CHIP CAP.	0.01uF	25V	B	GRM39B103K25PT	K22144803		1-	B	e1
C 1292	CHIP CAP.	0.01uF	25V	B	GRM39B103K25PT	K22144803		1-	B	g1
C 1293	CHIP TA.CAP.	1uF	10V		TESVSP1A105M-8R	K78100032		1-	B	d1
C 1294	CHIP CAP.	0.001uF	50V	B	GRM39B102K50PT	K22174821		1	B	e1
C 1294	CHIP CAP.	0.01uF	25V	B	GRM39B103K25PT	K22144803		2-	B	e1
C 1295	CHIP TA.CAP.	10uF	10V		TEMSVA1A106M-8R	K78100028		1-	B	e2
C 1296	CHIP CAP.	0.0047uF	50V	B	GRM39B472M50PT	K22174817		1-	A	D1
C 1297	AL.ELECTRO.CAP.	470uF	16V		RE3-16V471M 470UF	K40129066		1-	A	A1
C 1298	CHIP CAP.	0.0047uF	50V	B	GRM39B472M50PT	K22174817		1-	A	C2
C 1299	CHIP TA.CAP.	1uF	10V		TESVSP1A105M-8R	K78100032		1	A	C1
C 1299	CHIP TA.CAP.	10uF	10V		TEMSVA1A106M-8R	K78100028		2-	A	C1
C 1300	CHIP TA.CAP.	1uF	10V		TESVSP1A105M-8R	K78100032		1-	A	D1
C 1301	CHIP TA.CAP.	1uF	10V		TESVSP1A105M-8R	K78100032		1-	A	A4
C 1302	CHIP TA.CAP.	10uF	10V		TEMSVA1A106M-8R	K78100028		1-	B	g3
C 1303	AL.ELECTRO.CAP.	100uF	16V		SMG1CVB101M 100UF	K40129060		1		
C 1304	CHIP TA.CAP.	1uF	10V		TESVSP1A105M-8R	K78100032		1	A	A4
C 1304	CHIP TA.CAP.	10uF	6.3V		TESVSP0J106M-8R	K78080055		2-	A	A4
C 1305	AL.ELECTRO.CAP.	470uF	16V		RE3-16V471M 470UF	K40129066		1-	A	A1
C 1306	CHIP CAP.	0.015uF	25V	B	GRM39B153K25PT	K22144805		1-	A	C1
C 1308	CHIP CAP.	0.01uF	25V	B	GRM39B103K25PT	K22144803		1-	B	f1
C 1309	CHIP CAP.	0.1uF	16V	B	GRM39B104K16PT	K22124805		1-	B	g1
C 1310	AL.ELECTRO.CAP.	470uF	16V		RE3-16V471M 470UF	K40129066		1-	A	C1
C 1311	CHIP CAP.	10pF	50V	CH	GRM39CH100C50PT	K22174248		1		
C 1312	CHIP CAP.	10pF	50V	CH	GRM39CH100C50PT	K22174248		1-	A	A4
C 1313	CHIP CAP.	10pF	50V	CH	GRM39CH100C50PT	K22174248		1-	B	g3
C 1314	CHIP CAP.	10pF	50V	CH	GRM39CH100C50PT	K22174248		1-	A	A4
C 1315	CHIP CAP.	10pF	50V	CH	GRM39CH100C50PT	K22174248		1-	B	g3
C 1316	CHIP CAP.	10pF	50V	CH	GRM39CH100C50PT	K22174248		1-	A	A4
C 1317	CHIP CAP.	10pF	50V	CH	GRM39CH100C50PT	K22174248		1-	B	h3
C 1318	CHIP CAP.	15pF	50V	CH	GRM39CH150J50PT	K22174215		1	B	d3
C 1318	CHIP CAP.	18pF	50V	CH	GRM39CH180J50PT	K22174217		2-	B	d3
C 1319	CHIP CAP.	22pF	50V	CH	GRM39CH220J50PT	K22174219		1	B	a2
C 1319	CHIP CAP.	22pF	50V	UJ	GRM39UJ220J50PT	K22174316		2-	B	a2
C 1320	CHIP CAP.	22pF	50V	CH	GRM39CH220J50PT	K22174219		1	B	a2
C 1320	CHIP CAP.	22pF	50V	UJ	GRM39UJ220J50PT	K22174316		2-	B	a2
C 1321	CHIP CAP.	22pF	50V	CH	GRM39CH220J50PT	K22174219		1	B	a3
C 1321	CHIP CAP.	22pF	50V	UJ	GRM39UJ220J50PT	K22174316		2-	B	a3
C 1322	CHIP CAP.	22pF	50V	CH	GRM39CH220J50PT	K22174219		1	B	a3
C 1322	CHIP CAP.	22pF	50V	UJ	GRM39UJ220J50PT	K22174316		2-	B	a3
C 1323	CHIP CAP.	0.047uF	16V	B	GRM39B473K16PT	K22124804		1-	A	F2
C 1323	CHIP CAP.	0.0015uF	50V	B	GRM39B152M50PT	K22174811		6-	A	F2
C 1324	CHIP CAP.	0.1uF	16V	B	GRM39B104K16PT	K22124805		1-	B	g1
C 1325	CHIP TA.CAP.	1uF	10V		TESVSP1A105M-8R	K78100032		1-	B	b4
C 1326	CHIP TA.CAP.	1uF	10V		TESVSP1A105M-8R	K78100032		1-	B	b4
C 1327	CHIP CAP.	0.0033uF	50V	B	GRM39B332M50PT	K22174815		1-	B	f3
C 1328	CHIP TA.CAP.	10uF	10V		TEMSVA1A106M-8R	K78100028		1-	B	b3
C 1329	CHIP CAP.	0.01uF	25V	B	GRM39B103K25PT	K22144803		1-	B	b4
C 1330	CHIP CAP.	0.01uF	25V	B	GRM39B103K25PT	K22144803		1-	A	G5
C 1331	CHIP CAP.	0.01uF	25V	B	GRM39B103K25PT	K22144803		1-	A	G4
C 1332	CHIP CAP.	0.01uF	25V	B	GRM39B103K25PT	K22144803		1-	B	e2
C 1333	CHIP CAP.	15pF	50V	CH	GRM39CH150J50PT	K22174215		1	B	a4
C 1333	CHIP CAP.	5pF	50V	UJ	GRM39UJ050C50PT	K22174305		2-	B	a4
C 1334	CHIP CAP.	82pF	50V	CH	GRM39CH820J50PT	K22174233		1-	B	b4
C 1335	CHIP CAP.	82pF	50V	CH	GRM39CH820J50PT	K22174233		1-	A	G4
C 1336	CHIP CAP.	82pF	50V	CH	GRM39CH820J50PT	K22174233		1	A	G5
C 1336	CHIP CAP.	68pF	50V	CH	GRM39CH680J50PT	K22174231		2-	A	G5
C 1337	CHIP CAP.	82pF	50V	CH	GRM39CH820J50PT	K22174233		1-	B	b5
C 1338	CHIP CAP.	82pF	50V	CH	GRM39CH820J50PT	K22174233		1-	B	b5
C 1339	CHIP CAP.	82pF	50V	CH	GRM39CH820J50PT	K22174233		1-	B	c5
C 1340	CHIP CAP.	82pF	50V	CH	GRM39CH820J50PT	K22174233		1-	B	e3
C 1341	CHIP CAP.	82pF	50V	CH	GRM39CH820J50PT	K22174233		1-	A	C2
C 1342	CHIP CAP.	82pF	50V	CH	GRM39CH820J50PT	K22174233		1-	A	C2
C 1343	CHIP CAP.	0.047uF	16V	B	GRM39B473K16PT	K22124804		1-	B	e2
C 1344	CHIP CAP.	68pF	50V	CH	GRM39CH680J50PT	K22174231		1-	A	E4
C 1345	CHIP CAP.	82pF	50V	CH	GRM39CH820J50PT	K22174233		1-	B	c4
C 1346	CERAMIC CAP.	1pF	50V	CH	UP050CH010M-A-B	K28179056		1	B	a2

REF.	DESCRIPTION	VALUE	V/W	TOL.	MFR'S DESIG	VXSTD P/N	VERS.	LOT.	SIDE	LAY ADR
C 1347	CERAMIC CAP.	2.2pF	50V	CH	UP050CH2R2K-A-B	K28179005		1	B	a2
C 1347	CHIP CAP.	3pF	50V	CJ	GRM39CJ030C50PT	K22174204		2-	B	a2
C 1348	CERAMIC CAP.	0.01uF	16V	Y	EP050Y103N-A	K28129001		1	B	a3
C 1348	CHIP CAP.	0.01uF	25V	B	GRM39B103K25PT	K22144803		2-	B	a3
C 1349	CERAMIC CAP.	0.01uF	16V	Y	EP050Y103N-A	K28129001		1	B	c4
C 1349	CHIP CAP.	0.01uF	25V	B	GRM39B103K25PT	K22144803		2	B	c4
C 1349	CHIP CAP.	0.1uF	16V	B	GRM39B104K16PT	K22124805		3-	B	c4
C 1351	CHIP CAP.	0.047uF	16V	B	GRM39B473K16PT	K22124804		2-	B	a4
C 1352	CHIP TA.CAP.	2.2uF	6.3V		TESVSP0J225M-8R	K78080051		2-	B	f3
C 1353	CHIP CAP.	0.047uF	16V	B	GRM39B473K16PT	K22124804		2-	B	c3
C 1354	CHIP CAP.	0.047uF	16V	B	GRM39B473K16PT	K22124804		2-	B	g1
C 1355	CHIP CAP.	0.047uF	16V	B	GRM39B473K16PT	K22124804		2-	A	A1
C 1356	CHIP CAP.	0.047uF	16V	B	GRM39B473K16PT	K22124804		2-	B	a1
C 1357	CHIP CAP.	0.047uF	16V	B	GRM39B473K16PT	K22124804		2-	B	b4
C 1358	CHIP CAP.	100pF	50V	CH	GRM39CH101J50PT	K22174235		2-	B	g2
C 1360	CHIP CAP.	0.1uF	16V	B	GRM39B104K16PT	K22124805		2-	B	g2
C 1361	CHIP CAP.	0.01uF	25V	B	GRM39B103K25PT	K22144803		2-	A	C3
C 1362	CHIP TA.CAP.	0.22uF	20V		TEMSVA21D224M-8R	K78130022		2-	A	E1
C 1363	CERAMIC CAP.	0.01uF	16V	Y	EP050Y103N-A	K28129001		2-	B	b1
C 1363	CHIP CAP.	0.01uF	25V	B	GRM39B103K25PT	K22144803		5-	B	b1
C 1364	CHIP CAP.	0.01uF	25V	B	GRM39B103K25PT	K22144803		2-	B	c2
C 1365	CHIP CAP.	10pF	50V	CH	GRM39CH100D50PT	K22174211		2-	B	d4
C 1371	CHIP CAP.	10pF	50V	CH	GRM39CH100D50PT	K22174211		2-	B	e4
C 1372	CHIP CAP.	10pF	50V	CH	GRM39CH100D50PT	K22174211		2-	B	e4
C 1373	CHIP CAP.	10pF	50V	CH	GRM39CH100D50PT	K22174211		2-	B	e4
C 1374	CHIP CAP.	10pF	50V	CH	GRM39CH100D50PT	K22174211		2-	B	d4
C 1375	CHIP CAP.	10pF	50V	CH	GRM39CH100D50PT	K22174211		2-	B	d4
C 1376	CHIP CAP.	47pF	50V	CH	GRM39CH470J50PT	K22174227		2-	B	c3
C 1377	CHIP CAP.	0.1uF	16V	B	GRM39B104K16PT	K22124805		2-	B	b1
C 1378	CHIP CAP.	0.001uF	50V	B	GRM39B102K50PT	K22174821		2-	B	b1
C 1379	CHIP CAP.	1pF	50V	CK	GRM39CK010C50PT	K22174202		2-	B	a2
C 1380	CHIP CAP.	10pF	50V	CH	GRM39CH100D50PT	K22174211		2-	A	G3
C 1381	CHIP CAP.	22pF	50V	CH	GRM39CH220J50PT	K22174219		2-	A	G2
C 1382	CHIP CAP.	4pF	50V	CH	GRM39CH040C50PT	K22174205		2-	B	a3
C 1383	CHIP CAP.	15pF	50V	CH	GRM39CH150J50PT	K22174215		2-	B	c3
C 1384	CHIP CAP.	0.1uF	16V	B	GRM39B104K16PT	K22124805		2-	B	a2
C 1385	CHIP CAP.	3pF	50V	CJ	GRM39CJ030C50PT	K22174204		2-	B	d2
C 1386	CHIP CAP.	3pF	50V	CJ	GRM39CJ030C50PT	K22174204		2-	B	d2
C 1387	CHIP CAP.	12pF	50V	CH	GRM39CH120J50PT	K22174213		2-	B	d2
C 1388	CHIP TA.CAP.	10uF	10V		TEMSVA1A106M-8R	K78100028		2-	A	B2
C 1389	CHIP CAP.	1uF	10V	B	GRM40B105K10PT	K22100802		2-	A	C2
C 1390	CHIP CAP.	33pF	50V	CH	GRM39CH330J50PT	K22174223		2-	B	c3
C 1391	CHIP CAP.	33pF	50V	CH	GRM39CH330J50PT	K22174223		2-	B	d3
C 1393	CHIP CAP.	0.001uF	50V	B	GRM39B102K50PT	K22174821		2-	B	d3
C 1394	CHIP CAP.	0.001uF	50V	B	GRM39B102K50PT	K22174821		2-	B	d2
C 1395	CHIP CAP.	0.001uF	50V	B	GRM39B102K50PT	K22174821		2-	A	D2
C 1400	CHIP CAP.	0.047uF	16V	B	GRM39B473K16PT	K22124804		3-	B	e4
C 1407	CHIP CAP.	0.1uF	16V	B	GRM39B104K16PT	K22124805		2-	B	c5
C 1408	CHIP CAP.	0.1uF	16V	B	GRM39B104K16PT	K22124805		2-	B	e3
C 1409	CHIP CAP.	0.001uF	50V	B	GRM39B102K50PT	K22174821		2-	B	d3
C 1410	CHIP CAP.	0.001uF	50V	B	GRM39B102K50PT	K22174821		2-	B	c1
C 1411	CHIP CAP.	0.001uF	50V	B	GRM39B102K50PT	K22174821		2-	A	E1
C 1412	CHIP CAP.	100pF	50V	CH	GRM39CH101J50PT	K22174235		2-	A	E1
C 1413	CHIP CAP.	0.001uF	50V	B	GRM39B102K50PT	K22174821		2-	B	d1
C 1414	CHIP CAP.	100pF	50V	CH	GRM39CH101J50PT	K22174235		2-	B	d1
C 1415	CHIP CAP.	0.001uF	50V	B	GRM39B102K50PT	K22174821		2-	B	d1
C 1416	CHIP CAP.	100pF	50V	CH	GRM39CH101J50PT	K22174235		2-	A	E1
C 1417	CHIP CAP.	0.001uF	50V	B	GRM39B102K50PT	K22174821		2-	B	d1
C 1418	CHIP CAP.	100pF	50V	CH	GRM39CH101J50PT	K22174235		2-	A	E1
C 1419	CHIP CAP.	0.001uF	50V	B	GRM39B102K50PT	K22174821		2-	B	e1
C 1420	CHIP CAP.	0.001uF	50V	B	GRM39B102K50PT	K22174821		2-	B	e1
C 1421	CHIP CAP.	0.001uF	50V	B	GRM39B102K50PT	K22174821		2-	B	e1
C 1422	CHIP CAP.	0.001uF	50V	B	GRM39B102K50PT	K22174821		2-	B	e1
C 1423	CHIP CAP.	0.001uF	50V	B	GRM39B102K50PT	K22174821		2-	B	f1
C 1424	CHIP CAP.	0.001uF	50V	B	GRM39B102K50PT	K22174821		2-	B	g1
C 1425	CHIP CAP.	0.001uF	50V	B	GRM39B102K50PT	K22174821		2-	B	g1
C 1426	CHIP CAP.	0.001uF	50V	B	GRM39B102K50PT	K22174821		2-	B	g1
C 1427	CHIP CAP.	0.001uF	50V	B	GRM39B102K50PT	K22174821		2-	B	g5

MAIN Unit

REF.	DESCRIPTION	VALUE	V/W	TOL.	MFR'S DESIG	VXSTD P/N	VERS.	LOT.	SIDE	LAY ADR
C 1428	CHIP CAP.	0.001uF	50V	B	GRM39B102K50PT	K22174821		2-	B	g5
C 1429	CHIP CAP.	0.001uF	50V	B	GRM39B102K50PT	K22174821		2-	B	g5
C 1430	CHIP CAP.	0.001uF	50V	B	GRM39B102K50PT	K22174821		2-	B	g5
C 1431	CHIP CAP.	0.001uF	50V	B	GRM39B102K50PT	K22174821		2-	A	C4
C 1432	CHIP CAP.	0.001uF	50V	B	GRM39B102K50PT	K22174821		2-	A	B4
C 1433	CHIP CAP.	0.001uF	50V	B	GRM39B102K50PT	K22174821		2-	A	B4
C 1434	CHIP CAP.	0.001uF	50V	B	GRM39B102K50PT	K22174821		2-	A	B4
C 1435	CHIP CAP.	0.001uF	50V	B	GRM39B102K50PT	K22174821		2-	B	f4
C 1436	CHIP CAP.	0.001uF	50V	B	GRM39B102K50PT	K22174821		2-	B	d1
C 1437	CHIP CAP.	100pF	50V	CH	GRM39CH101J50PT	K22174235		2-	B	d1
C 1438	CHIP CAP.	0.001uF	50V	B	GRM39B102K50PT	K22174821		2-	B	g1
C 1439	CHIP CAP.	6pF	50V	CH	GRM39CH060D50PT	K22174207		2-	A	F1
C 1440	CHIP CAP.	22pF	50V	CH	GRM39CH220J50PT	K22174219		2-	B	c2
C 1441	CHIP CAP.	22pF	50V	CH	GRM39CH220J50PT	K22174219		2-	B	c2
C 1442	CHIP CAP.	220pF	50V	CH	GRM39CH221J50PT	K22174243		2-	A	E1
C 1443	CHIP CAP.	220pF	50V	CH	GRM39CH221J50PT	K22174243		2-	B	d1
C 1444	CHIP CAP.	0.001uF	50V	B	GRM39B102K50PT	K22174821		2-	A	E2
C 1445	CHIP CAP.	100pF	50V	CH	GRM39CH101J50PT	K22174235		2-	A	E1
C 1446	CHIP CAP.	100pF	50V	CH	GRM39CH101J50PT	K22174235		2-	B	c2
C 1447	CHIP CAP.	0.001uF	50V	B	GRM39B102K50PT	K22174821		2-	B	d1
C 1448	CHIP CAP.	0.001uF	50V	B	GRM39B102K50PT	K22174821		2-	B	d2
C 1450	CHIP CAP.	0.001uF	50V	B	GRM39B102K50PT	K22174821		2-	B	f1
C 1451	CHIP CAP.	0.001uF	50V	B	GRM39B102K50PT	K22174821		2-	B	d1
C 1452	CHIP TA.CAP.	0.47uF	20V		TEMSVA21D474M-8R	K78130023		2-	A	B5
C 1453	CHIP CAP.	3pF	50V	CJ	GRM39CJ030C50PT	K22174204		2-	B	c3
C 1454	CHIP CAP.	220pF	50V	CH	GRM39CH221J50PT	K22174243		2-	A	B3
C 1455	CHIP CAP.	100pF	50V	CH	GRM39CH101J50PT	K22174235		2-	B	g3
C 1456	CHIP CAP.	2pF	50V	CK	GRM39CK020C50PT	K22174203		2-	A	H1
C 1457	CHIP CAP.	0.001uF	50V	B	GRM39B102K50PT	K22174821		2-	B	a1
C 1458	CHIP CAP.	4pF	50V	CH	GRM39CH040C50PT	K22174205		2-	B	a1
C 1459	CHIP CAP.	3pF	50V	CJ	GRM39CJ030C50PT	K22174204		2-	B	a2
C 1460	CHIP CAP.	5pF	50V	CH	GRM39CH050C50PT	K22174206		2-	B	a1
C 1461	CHIP CAP.	5pF	50V	CH	GRM39CH050C50PT	K22174206		2-	B	a3
C 1462	CHIP CAP.	0.001uF	50V	B	GRM39B102K50PT	K22174821		2-	A	A4
C 1463	CHIP CAP.	0.001uF	50V	B	GRM39B102K50PT	K22174821		2-	A	A4
C 1464	CHIP CAP.	0.001uF	50V	B	GRM39B102K50PT	K22174821		2-	B	f1
C 1465	CHIP CAP.	100pF	50V	CH	GRM39CH101J50PT	K22174235		2-	B	f1
C 1466	CHIP CAP.	0.01uF	25V	B	GRM39B103K25PT	K22144803		2-	B	c2
C 1467	CERAMIC CAP.	0.047uF	50V	F	UP050F473Z-A-B	K28179002		2-	B	d4
C 1467	CHIP CAP.	0.047uF	16V	B	GRM39B473K16PT	K22124804		5-	B	d4
C 1468	CERAMIC CAP.	0.001uF	50V	B	UP050B102K-A-B	K28179001		4-		
C 1469	CHIP CAP.	0.001uF	50V	B	GRM39B102K50PT	K22174821		3-		
C 1470	CHIP CAP.	0.001uF	50V	B	GRM39B102K50PT	K22174821		3-		
C 1471	CHIP CAP.	0.1uF	16V	B	GRM39B104K16PT	K22124805		3-		
C 1472	CERAMIC CAP.	0.1uF	50V	F	UP050F104Z-A-B	K28179003		3-		
C 1472	CHIP CAP.	0.1uF	16V	B	GRM39B104K16PT	K22124805		5-		
C 1473	CERAMIC CAP.	0.1uF	50V	F	UP050F104Z-A-B	K28179003		3-		
C 1473	CHIP CAP.	0.1uF	16V	B	GRM39B104K16PT	K22124805		5-		
C 1474	CERAMIC CAP.	0.1uF	50V	F	UP050F104Z-A-B	K28179003		3-		
C 1474	CHIP CAP.	0.1uF	16V	B	GRM39B104K16PT	K22124805		5-		
C 1475	CERAMIC CAP.	0.01uF	16V	Y	EP050Y103N-A	K28129001		6-		
C 1476	CERAMIC CAP.	0.01uF	16V	Y	EP050Y103N-A	K28129001		6-		
C 1477	CHIP CAP.	0.001uF	50V	B	GRM39B102K50PT	K22174821		34-		
CD1001	CERAMIC DISC				CDA10.7MG1-A	H7900890		1-	A	G4
CD1002	CERAMIC DISC				CDB455C16	H7900740		1-	A	F4
CF1001	CERAMIC FILTER				SFE10.7MA5-A	H3900408		1-	A	G4
CF1002	CERAMIC FILTER				KBF-455R-15A	H3900394		1-	A	G4
CO1001	CERAMIC OSC	16MHz			CSA16.00MXZ040	H7901090		1		
CV1001	HELICAL RESONATOR	440MHZ			H5T KE-07259 440M	L4020146		1-	A	G2
CV1001	HELICAL RESONATOR	440MHZ			H5T-440 440M	L4020161		5-	A	G2
CV1002	HELICAL RESONATOR	440MHZ			H5T KE-07259 440M	L4020146		1-	A	E2
CV1002	HELICAL RESONATOR	440MHZ			H5T-440 440M	L4020161		5-	A	E2
D 1001	DIODE				DAN235U TL	G2070176		1-	B	a3
D 1002	DIODE				DAN202U T106	G2070162		1-	B	b2
D 1003	DIODE				DAN202U T106	G2070162		1-	B	a1
D 1004	DIODE				DAN235U TL	G2070176		1-	B	a1
D 1005	DIODE				DAN235U TL	G2070176		1-	B	a1
D 1006	DIODE				DAN235U TL	G2070176		1-	B	c3

REF.	DESCRIPTION	VALUE	V/W	TOL.	MFR'S DESIG	VXSTD P/N	VERS.	LOT.	SIDE	LAY ADR
D 1007	DIODE				1SV271 TPH3	G2070476		1-	B	b1
D 1008	DIODE				D1N60-4070	G2060013		1-	A	G1
D 1009	DIODE				HSB88WSTR	G2070290		1-	A	E3
D 1010	DIODE				HSB88WSTR	G2070290		1-	A	E3
D 1011	DIODE				DAN202U T106	G2070162		1-	B	c1
D 1013	DIODE				1SV230 TPH3	G2070126		1-	B	a2
D 1015	DIODE				1SV230 TPH3	G2070126		1-	B	a2
D 1016	DIODE				DAN235U TL	G2070176		1-	A	F2
D 1017	DIODE				DAN235U TL	G2070176		1-	B	d3
D 1018	DIODE				02CZ5.1Y TE85R	G2070062		1-	A	F1
D 1019	DIODE				DAP202U T106	G2070160		1-	A	F1
D 1020	DIODE				1SV271 TPH3	G2070476		1-	B	b1
D 1021	DIODE				1SV271 TPH3	G2070476		1-	B	b1
D 1022	DIODE				1SV271 TPH3	G2070476		1-	B	b2
D 1023	DIODE				1SV271 TPH3	G2070476		1-	B	b2
D 1024	DIODE				DAN235U TL	G2070176		1-	B	c5
D 1026	DIODE				1SV230 TPH3	G2070126		1-	B	a3
D 1027	DIODE				1SS302 TE85R	G2070088		1-	B	b2
D 1028	DIODE				DAN235U TL	G2070176		1-	A	G3
D 1029	DIODE				1SS302 TE85R	G2070088		1-	B	e3
D 1031	DIODE				1SV230 TPH3	G2070126		1-	B	a3
D 1032	DIODE				DAN235U TL	G2070176		1-	B	b2
D 1033	DIODE				DAN235U TL	G2070176		1-	B	a3
D 1034	DIODE				DAN235U TL	G2070176		1-	B	d2
D 1035	DIODE				HSB88WSTR	G2070290		1-	A	G3
D 1036	DIODE				02CZ5.1Y TE85R	G2070062		1-	B	d1
D 1037	DIODE				DAN235U TL	G2070176		1-	B	b3
D 1038	DIODE				1SV229 TPH3	G2070256		1-	B	d1
D 1039	DIODE				HVU306A5TRF	G2070132		1-	B	e2
D 1040	DIODE				1SV271 TPH3	G2070476		1-	B	c4
D 1041	DIODE				DAN235U TL	G2070176		1-	B	d2
D 1042	DIODE				1SV229 TPH3	G2070256		1-	B	d2
D 1043	DIODE				DAN235U TL	G2070176		1-	A	G3
D 1044	DIODE				1SV229 TPH3	G2070256		1		
D 1045	DIODE				DAN235U TL	G2070176		1-	A	G3
D 1046	DIODE				DAN235U TL	G2070176		1-	B	c5
D 1047	DIODE				1SV229 TPH3	G2070256		1		
D 1048	DIODE				DAN202U T106	G2070162		1		
D 1050	DIODE				HSM198S-TR	G2070570		1-	B	b4
D 1051	DIODE				DAN202U T106	G2070162		1-	B	f2
D 1052	DIODE				1SS302 TE85R	G2070088		1-	A	F5
D 1053	DIODE				1SS302 TE85R	G2070088		1-	A	F5
D 1054	DIODE				DAN202U T106	G2070162		1-	B	b5
D 1055	DIODE				1SS302 TE85R	G2070088		1-	B	e3
D 1056	DIODE				1SS302 TE85R	G2070088		1-	B	d4
D 1057	DIODE				1SS302 TE85R	G2070088		1-	B	d4
D 1058	DIODE				1SS302 TE85R	G2070088		1-	B	d4
D 1059	DIODE				1SS302 TE85R	G2070088		1-	B	d4
D 1060	DIODE				HSM198S-TR	G2070570		1-	B	f2
D 1061	DIODE				DAN235U TL	G2070176		1-	B	b4
D 1062	DIODE				HSM198S-TR	G2070570		1-	B	e2
D 1063	DIODE				DAN202U T106	G2070162		1-	B	f3
D 1064	DIODE				1SS302 TE85R	G2070088		1-	B	c4
D 1065	DIODE				DAP202U T106	G2070160		1-	B	f2
D 1066	DIODE				1SS302 TE85R	G2070088		1-	B	e4
D 1067	DIODE				1SS302 TE85R	G2070088		1-	B	e4
D 1068	DIODE				1SS302 TE85R	G2070088		1-	B	e4
D 1069	DIODE				1SS302 TE85R	G2070088		1-	B	e4
D 1070	DIODE				DAN202U T106	G2070162		1	B	g3
D 1070	DIODE				DAP202U T106	G2070160		2-	B	g3
D 1071	DIODE				DAN235U TL	G2070176		1-	A	C5
D 1072	DIODE				DAN202U T106	G2070162		1-	B	c1
D 1073	DIODE				1SS302 TE85R	G2070088		2-	B	f3
D 1074	DIODE				DAN202U T106	G2070162		2-	B	f2
D 1075	DIODE				DAN202U T106	G2070162		2-	B	b4
D 1076	DIODE				DAN202U T106	G2070162		2-	B	b2
D 1077	DIODE				1SS302 TE85R	G2070088		2-	B	b2
D 1078	DIODE				DAN202U T106	G2070162		2-	A	E1

MAIN Unit

REF.	DESCRIPTION	VALUE	V/W	TOL.	MFR'S DESIG	VXSTD P/N	VERS.	LOT.	SIDE	LAY ADR
D 1079	DIODE				DAN235U TL	G2070176		2-	B	d2
D 1080	DIODE				1SS400 TE61	G2070634		2-	A	B2
D 1080	DIODE				MA2S111-(TX)	G2070614		13-	A	B2
D 1081	DIODE				1SS270TJ	G2060004		41-		
J 1001	CONNECTOR				TMP-J01X-A2	P1090255		1-	A	G4
J 1002	CONNECTOR				TMP-J01X-A2	P1090255		1-	A	G1
J 1003	CONNECTOR				TMP-J01X-A2	P1090255		1-	A	G1
J 1004	CONNECTOR				TMP-J01X-A2	P1090255		1-	A	G4
J 1005	CONNECTOR				TMP-J01X-A2	P1090255		1-	A	E2
J 1007	CONNECTOR				12FMZ-BT	P1090901		1-	A	A1
J 1008	CONNECTOR				20FMZ-BT	P1090903		1-	A	B4
J 1010	CONNECTOR				9230B-1-08Z009-T	P0090684		1	A	G2
J 1011	CONNECTOR				12FMZ-BT	P1090901		1-	A	E1
J 1012	CONNECTOR				TMP-J01X-A2	P1090255		1-	A	D2
J 1014	CONNECTOR				9230B-1-08Z009-T	P0090684		1	A	G2
J 1015	CONNECTOR				9230B-1-08Z009-T	P0090684		1	A	F2
J 1016	CONNECTOR				TMP-J01X-A2	P1090255		1-	A	C2
J 1017	CONNECTOR				20FMZ-BT	P1090903		1-	A	B5
J 1018	CONNECTOR				16FMZ-BT	P1090902		1-	A	B4
J 1019	CONNECTOR				SB20-08WS	P0090615		1-	A	C4
J 1020	CONNECTOR				R41-4863J	P1090894		1-	A	A5
J 1020	CONNECTOR				R41-4863J	P1090894		5-	A	A5
J 1021	CONNECTOR				SB20-06WS	P0090613		1-	A	C1
J 1022	CONNECTOR				SB20-09WS	P0090616		1-	A	B1
J 1023	CONNECTOR				SB20-02WS	P0090609		1-	A	B2
JP1001	WIRE ASSY				A0898 #241897	T9206721		1-		
JP1001	WIRE ASSY				BLK 90 **	T9318110		5-		
JP1003	WIRE ASSY				A0898 #241899	T9206723		1-		
JP1005	WIRE ASSY				A0898 #241899	T9206723		1-		
JP1007	WIRE ASSY				A0898 #241899	T9206723		1-		
JP1009	WIRE ASSY				A0898 #241899	T9206723		1-		
JP1011	WIRE ASSY				A0898 #241900	T9206724		1-		
JP1013	WIRE ASSY				A0898 #241901	T9206725		1-		
JP1015	WIRE ASSY				A0898 #241902	T9206726		1-		
JP1016	WIRE ASSY				GRN 70 2/2	T50507000		41-		
L 1001	M.RFC	100uH			FLC32T-101J	L1690227		1-	A	G1
L 1002	M.RFC	100uH			FLC32T-101J	L1690227		1	A	F2
L 1002	M.RFC	120uH			FLC32T-121J	L1690228		2-	A	F2
L 1003	M.RFC	100uH			FLC32T-101J	L1690227		1	A	E2
L 1003	M.RFC	120uH			FLC32T-121J	L1690228		2-	A	E2
L 1004	M.RFC	100uH			FLC32T-101J	L1690227		1-	A	F3
L 1005	M.RFC	10uH			FLC32T-100J	L1690215		1-	A	E2
L 1006	CHIP COIL	0.033uH			LQN21A33NJ04	L1690615		1	A	G1
L 1006	CHIP COIL	0.1uH			LQN21AR10J04	L1690620		2-	A	G1
L 1007	CHIP COIL	0.22uH			LQN21AR22J04	L1690600		1	A	G1
L 1007	CHIP COIL	3.3uH			C2520F-3R3K	L1690590		2-	A	G1
L 1008	M.RFC	0.068uH			HK2125 68NK-T	L1690387		1	A	H1
L 1008	M.RFC	0.022uH			HK2125 22NK-T	L1690381		2-	A	H1
L 1009	CHIP COIL	1.5uH			C2520C-1R5K	L1690729		1-	A	G1
L 1010	M.RFC	100uH			FLC32T-101J	L1690227		1-	A	F2
L 1011	CHIP COIL	0.018uH			LQN21A18NJ04	L1690612		1-	A	G2
L 1012	CHIP COIL	0.22uH			LQN21AR22J04	L1690600		1-	A	H1
L 1013	M.RFC	100uH			FLC32T-101J	L1690227		1-	A	F2
L 1014	M.RFC	100uH			FLC32T-101J	L1690227		1-	A	G1
L 1015	CHIP COIL	0.22uH			LQN21AR22J04	L1690600		1-	A	G2
L 1016	M.RFC	0.0082uH			HK2125 8N2K-T	L1690376		1	B	b1
L 1016	M.RFC	0.18uH			LK2125 R18K-T	L1690310		2-	B	b1
L 1017	M.RFC	0.047uH			HK2125 47NK-T	L1690385		1-	B	a2
L 1018	M.RFC	1.8uH			FLC32T-1R8K	L1690206		1-	A	F1
L 1019	CHIP COIL	0.1uH			C2520C-R10J	L1690544		1	A	G1
L 1019	CHIP COIL	0.15uH			C2520C-R15J	L1690546		2-	A	G1
L 1020	CHIP COIL	0.082uH			C2520C-82NK	L1690543		1-	A	G1
L 1021	CHIP COIL	0.082uH			C2520C-82NK	L1690543		1	A	F1
L 1021	CHIP COIL	0.15uH			C2520C-R15J	L1690546		2-	A	F1
L 1022	CHIP COIL	0.1uH			C2520C-R10J	L1690544		1	A	F1
L 1022	CHIP COIL	0.082uH			C2520C-82NK	L1690543		2-	A	F1
L 1023	CHIP COIL	0.018uH			LQN21A18NJ04	L1690612		1-	A	G3
L 1024	CHIP COIL	0.033uH			LQN21A33NJ04	L1690615		1-	A	G3

REF.	DESCRIPTION	VALUE	V/W	TOL.	MFR'S DESIG	VXSTD P/N	VERS.	LOT.	SIDE	LAY ADR
L 1025	CHIP COIL	0.22uH			LQN21AR22J04	L1690600		1-	A	G2
L 1027	M.RFC	0.33uH			LK2125 R33K-T	L1690313		1-	B	d2
L 1028	M.RFC	100uH			FLC32T-101J	L1690227		1-	A	F2
L 1029	M.RFC	10uH			FLC32T-100J	L1690215		1-	A	D2
L 1031	M.RFC	100uH			FLC32T-101J	L1690227		1-	A	G2
L 1032	CHIP COIL	5.6uH			C2520F-5R6K	L1690593		1-	A	G2
L 1034	M.RFC	0.47uH			LK2125 R47K-T	L1690315		1-	B	a4
L 1035	M.RFC	10uH			LK2125 100K-T	L1690331		1-	A	G3
L 1036	M.RFC	470uH			FLC32T-471J	L1690235		1-	A	F4
L 1037	M.RFC	100uH			FLC32T-101J	L1690227		1-	A	F4
L 1038	M.RFC	100uH			FLC32T-101J	L1690227		1-	A	D3
L 1039	M.RFC	100uH			FLC32T-101J	L1690227		1-	A	E5
L 1040	M.RFC	100uH			FLC32T-101J	L1690227		1-	A	E4
L 1041	M.RFC	100uH			FLC32T-101J	L1690227		1-	A	C4
L 1043	M.RFC	100uH			FLC32T-101J	L1690227		1-	A	C4
L 1044	M.RFC	100uH			FLC32T-101J	L1690227		1-	A	C5
L 1045	M.RFC	100uH			FLC32T-101J	L1690227		1-	A	C4
L 1046	M.RFC	220uH			FLC32T-221J	L1690231		1-	A	F1
L 1047	M.RFC	220uH			FLC32T-221J	L1690231		1-	A	F1
L 1048	M.RFC	220uH			FLC32T-221J	L1690231		1-	A	F2
L 1048	M.RFC	6.8uH			FLC32T-6R8K	L1690213		6-	A	F2
L 1049	M.RFC	220uH			FLC32T-221J	L1690231		1-	A	F2
L 1050	M.RFC	220uH			FLC32T-221J	L1690231		1-	A	F2
L 1050	M.RFC	6.8uH			FLC32T-6R8K	L1690213		6-	A	F2
L 1051	M.RFC	220uH			FLC32T-221J	L1690231		1-	A	F2
L 1052	M.RFC	22uH			LK2125 220M-T	L1690335		1-	A	A4
L 1053	M.RFC	100uH			FLC32T-101J	L1690227		1-	A	D2
L 1054	M.RFC	100uH			FLC32T-101J	L1690227		1-	A	C3
L 1055	CHIP COIL	10uH			C2520F-100K	L1690596		2-	A	A4
L 1056	M.RFC	0.27uH			LK2125 R27K-T	L1690312		2-	B	c3
L 1057	M.RFC	0.27uH			LK1608 R27K-T	L1690411		2-	B	b3
L 1058	M.RFC	3.3uH			LK2125 3R3K-T	L1690325		2-	B	d3
L 1059	M.RFC	0.18uH			LK2125 R18K-T	L1690310		2-	B	d3
L 1060	M.RFC	0.022uH			ELJ-RE22NJF2	L1690718		2-	A	E2
L 1061	M.RFC	220uH			FLC32T-221J	L1690231		2-	A	A4
L 1062	M.RFC	220uH			FLC32T-221J	L1690231		2-	A	A4
L 1063	M.RFC	220uH			FLC32T-221J	L1690231		2-	A	A1
L 1064	M.RFC	0.1uH			LK1608 R10K-T	L1690407		2-	A	E2
L 1065	M.RFC	0.01uH			HK1608 10NJ-T	L1690516		2-	B	d2
L 1066	M.RFC	0.1uH			LK1608 R10K-T	L1690407		2-	B	a1
L 1067	M.RFC	0.22uH			LK1608 R22K-T	L1690410		2-	B	a1
Q 1001	IC				CXP2005M-T6	G1091846		1	B	c3
Q 1001	IC				NJU3714G-TE1	G1092768		2-	B	c3
Q 1002	TRANSISTOR				2SC4047-TA	G3340477		1-	B	a1
Q 1003	TRANSISTOR				2SC2954-T2	G3329547		1-	A	F2
Q 1004	FET				SGM2016M-T7	G4070005		1-	A	G1
Q 1004	FET				SGM2016AM-T7	G4070012		5-	A	G1
Q 1005	FET				SGM2016M-T7	G4070005		1-	B	a1
Q 1005	FET				SGM2016AM-T7	G4070012		5-	B	a1
Q 1006	TRANSISTOR				2SC3356-T2B R25	G3333567E		1-	A	F2
Q 1007	TRANSISTOR				2SC2812L6-TA	G3328127F		1-	B	c1
Q 1007	TRANSISTOR				2SC2812NL6-TB	G3328128F		19-	B	c1
Q 1008	TRANSISTOR				2SC3356-T2B R25	G3333567E		1-	B	b1
Q 1009	TRANSISTOR				2SC2714YTE85R	G3327147Y		1-	A	F1
Q 1010	IC				CXP2005M-T6	G1091846		1	B	f2
Q 1010	IC				NJU3714G-TE1	G1092768		2-	B	f2
Q 1011	FET				SGM2016M-T7	G4070005		1-	B	a3
Q 1011	FET				SGM2016AM-T7	G4070012		5-	B	a3
Q 1012	FET				3SK131-T2B V12	G4801317B		1-	B	a2
Q 1013	FET				SST310-T1	G4070009		1-	B	d3
Q 1014	IC				M62352GP-70EC	G1092689		1-	A	D1
Q 1016	TRANSISTOR				2SC4047-TA	G3340477		1-	A	D3
Q 1018	TRANSISTOR				IMD3 T108	G3070053		1-	A	D3
Q 1019	TRANSISTOR				IMD3 T108	G3070053		1-	B	b2
Q 1020	IC				UPC1679G-E(TAPING)	G1092714		1-	A	D2
Q 1021	TRANSISTOR				2SC2812L6-TA	G3328127F		1-	B	e3
Q 1021	TRANSISTOR				2SC2812NL6-TB	G3328128F		19-	B	e3
Q 1023	FET				SST310-T1	G4070009		1-	A	G2

MAIN Unit

REF.	DESCRIPTION	VALUE	V/W	TOL.	MFR'S DESIG	VXSTD P/N	VERS.	LOT.	SIDE	LAY ADR
Q 1024	TRANSISTOR				2SC4047-TA	G3340477		1-	B	b2
Q 1025	TRANSISTOR				2SC2812L6-TA	G3328127F		1-	B	e2
Q 1025	TRANSISTOR				2SC2812NL6-TB	G3328128F		19-	B	e2
Q 1026	FET				2SK302Y TE85R	G3803027Y		1-	B	c4
Q 1027	FET				2SK302Y TE85R	G3803027Y		1-	B	c4
Q 1028	FET				SST310-T1	G4070009		1-	A	F3
Q 1029	FET				SST310-T1	G4070009		1-	A	F3
Q 1030	IC				TC4W53F TE12L	G1091340		1-	B	e2
Q 1031	FET				3SK131-T2B V12	G4801317B		1-	B	c4
Q 1032	TRANSISTOR				2SC4047-TA	G3340477		1-	B	b5
Q 1033	IC				CXA1611N-T4	G1092695		1-	A	G4
Q 1034	TRANSISTOR				2SC4047-TA	G3340477		1-	B	b3
Q 1035	FET				3SK131-T2B V12	G4801317B		1-	B	a4
Q 1036	FET				3SK131-T2B V12	G4801317B		1-	B	b5
Q 1037	FET				2SK302GR TE85R	G3803027G		1-	B	b4
Q 1038	FET				2SK302GR TE85R	G3803027G		1-	B	a5
Q 1039	IC				AN6041-(NT)	G1092691		1-	A	C3
Q 1040	FET				2SK302GR TE85R	G3803027G		1-	B	b4
Q 1041	IC				AK7712VT	G1092699		1-	A	A3
Q 1042	FET				3SK131-T2B V12	G4801317B		1-	B	e3
Q 1043	IC				TC4W53F TE12L	G1091340		1-	A	B3
Q 1044	IC				TC4S66F TE85R	G1090893		1-	B	f3
Q 1045	FET				3SK131-T2B V12	G4801317B		1-	B	e2
Q 1046	TRANSISTOR				2SC2812L6-TA	G3328127F		1-	B	c4
Q 1046	TRANSISTOR				2SC2812NL6-TB	G3328128F		19-	B	c4
Q 1047	TRANSISTOR				2SC2812L6-TA	G3328127F		1-	B	c5
Q 1047	TRANSISTOR				2SC2812NL6-TB	G3328128F		19-	B	c5
Q 1048	TRANSISTOR				2SA1563-TB	G3115638		1-	B	c5
Q 1049	FET				3SK131-T2B V12	G4801317B		1-	B	e2
Q 1050	IC				TC4W53F TE12L	G1091340		1-	A	B2
Q 1051	IC				TC4S66F TE85R	G1090893		1-	B	g2
Q 1052	TRANSISTOR				2SC2812L6-TA	G3328127F		1-	B	e2
Q 1052	TRANSISTOR				2SC2812NL6-TB	G3328128F		19-	B	e2
Q 1053	TRANSISTOR				2SC2812L6-TA	G3328127F		1-	B	e1
Q 1053	TRANSISTOR				2SC2812NL6-TB	G3328128F		19-	B	e1
Q 1054	IC				MC3372SVMEL	G1091654		1-	A	F4
Q 1055	IC				CXA1846N-T4	G1092690		1-	A	A2
Q 1056	IC				TC4W53F TE12L	G1091340		1-	A	B3
Q 1057	FET				2SK160-T2B K6	G3801607F		1-	B	e1
Q 1058	IC				TC4W53F TE12L	G1091340		1-	A	C1
Q 1059	TRANSISTOR				2SC4047-TA	G3340477		1-	B	g2
Q 1060	IC				NJM2904V-TE1	G1091677		1-	A	F1
Q 1061	FET				2SK160-T2B K6	G3801607F		1-	B	g3
Q 1062	IC				NJM2904V-TE1	G1091677		1-	A	F1
Q 1063	IC				NJM2904V-TE1	G1091677		1-	A	A2
Q 1064	IC				NJM2904V-TE1	G1091677		1-	A	A2
Q 1065	IC				NJM2904V-TE1	G1091677		1-	A	F1
Q 1066	IC				NJM2904V-TE1	G1091677		1-	A	D1
Q 1067	IC				NJM2904V-TE1	G1091677		1-	A	A2
Q 1068	IC				NJM2904V-TE1	G1091677		1-	A	B3
Q 1069	IC				TDA2003H	G1090815		1-	A	B1
Q 1070	IC				NJM2904V-TE1	G1091677		1-	A	B3
Q 1071	IC				NJM2904V-TE1	G1091677		1-	A	B3
Q 1072	TRANSISTOR				2SC3444-T11-1E	G3334448E		1		
Q 1073	TRANSISTOR				2SC2812L6-TA	G3328127F		1		
Q 1074	IC				NJM2904V-TE1	G1091677		1-	A	A2
Q 1076	IC				NJM2904V-TE1	G1091677		1-	A	C1
Q 1078	IC				NJM2904V-TE1	G1091677		1-	A	B3
Q 1081	IC				NJM2904V-TE1	G1091677		1-	A	D2
Q 1081	IC				NJM2904V-TE1	G1091677		5-	A	D2
Q 1082	TRANSISTOR				2SC4047-TA	G3340477		1-	A	F3
Q 1083	IC				TC7S32FU TE85R	G1091529		2-	B	g3
Q 1084	TRANSISTOR				2SC2812L6-TA	G3328127F		2-	B	a4
Q 1084	TRANSISTOR				2SC2812NL6-TB	G3328128F		19-	B	a4
R 1001	CHIP RES.	1k	1/16W	5%	RMC1/16 102JATP	J24185102		1-	B	a3
R 1002	CHIP RES.	150	1/16W	5%	RMC1/16 151JATP	J24185151		1-	B	c2
R 1003	CHIP RES.	150	1/16W	5%	RMC1/16 151JATP	J24185151		1-	B	a3
R 1004	CHIP RES.	150k	1/16W	5%	RMC1/16 154JATP	J24185154		1	B	b1

REF.	DESCRIPTION	VALUE	V/W	TOL.	MFR'S DESIG	VXSTD P/N	VERS.	LOT.	SIDE	LAY ADR
R 1004	CHIP RES.	56k	1/16W	5%	RMC1/16 563JATP	J24185563		2-	B	b1
R 1005	CHIP RES.	1k	1/16W	5%	RMC1/16 102JATP	J24185102		1-	B	c2
R 1006	CHIP RES.	47	1/16W	5%	RMC1/16 470JATP	J24185470		1-	B	c2
R 1006	CHIP RES.	0	1/16W	5%	RMC1/16 000JATP	J24185000		2-	B	c2
R 1007	CHIP RES.	15k	1/16W	5%	RMC1/16 153JATP	J24185153		1-	B	b1
R 1008	CHIP RES.	150	1/16W	5%	RMC1/16 151JATP	J24185151		1-	B	c2
R 1009	CHIP RES.	39k	1/16W	5%	RMC1/16 393JATP	J24185393		1		
R 1010	CHIP RES.	39k	1/16W	5%	RMC1/16 393JATP	J24185393		1		
R 1011	CHIP RES.	150k	1/16W	5%	RMC1/16 154JATP	J24185154		1		
R 1012	CHIP RES.	150k	1/16W	5%	RMC1/16 154JATP	J24185154		1	B	c1
R 1012	CHIP RES.	56k	1/16W	5%	RMC1/16 563JATP	J24185563		2-	B	c1
R 1013	CHIP RES.	150	1/16W	5%	RMC1/16 151JATP	J24185151		1-	A	G1
R 1014	CHIP RES.	150	1/16W	5%	RMC1/16 151JATP	J24185151		1-	A	G1
R 1015	CHIP RES.	1k	1/16W	5%	RMC1/16 102JATP	J24185102		1		
R 1016	CHIP RES.	100	1/2W	5%	RMC1/2 101JCTP	J24275101		1-	A	E2
R 1017	CHIP RES.	10k	1/16W	5%	RMC1/16 103JATP	J24185103		1-	B	b1
R 1018	CHIP RES.	47	1/16W	5%	RMC1/16 470JATP	J24185470		1-	A	F2
R 1019	CHIP RES.	100k	1/16W	5%	RMC1/16 104JATP	J24185104		1-	A	G1
R 1020	CHIP RES.	150	1/16W	5%	RMC1/16 151JATP	J24185151		1-	B	c3
R 1021	CHIP RES.	100k	1/16W	5%	RMC1/16 104JATP	J24185104		1-	B	b1
R 1022	CHIP RES.	100k	1/16W	5%	RMC1/16 104JATP	J24185104		1-	B	a1
R 1023	CHIP RES.	100k	1/16W	5%	RMC1/16 104JATP	J24185104		1		
R 1024	CHIP RES.	150	1/16W	5%	RMC1/16 151JATP	J24185151		1-	A	G1
R 1025	CHIP RES.	4.7k	1/16W	5%	RMC1/16 472JATP	J24185472		1	B	d3
R 1025	CHIP RES.	470	1/16W	5%	RMC1/16 471JATP	J24185471		2-	B	d3
R 1026	CHIP RES.	560	1/16W	5%	RMC1/16 561JATP	J24185561		1-	A	F2
R 1027	CHIP RES.	1M	1/16W	5%	RMC1/16 105JATP	J24185105		1-	B	b1
R 1028	CHIP RES.	4.7k	1/16W	5%	RMC1/16 472JATP	J24185472		1	B	c1
R 1028	CHIP RES.	1k	1/16W	5%	RMC1/16 102JATP	J24185102		2-	B	c1
R 1029	CHIP RES.	100	1/16W	5%	RMC1/16 101JATP	J24185101		1-	B	a2
R 1030	CHIP RES.	100	1/16W	5%	RMC1/16 101JATP	J24185101		1-	B	a1
R 1031	CHIP RES.	10k	1/16W	5%	RMC1/16 103JATP	J24185103		1-	B	b1
R 1031	CHIP RES.	22k	1/16W	5%	RMC1/16 223JATP	J24185223		2-	B	b1
R 1032	CHIP RES.	560	1/16W	5%	RMC1/16 561JATP	J24185561		1-	B	a2
R 1033	CHIP RES.	2.2k	1/16W	5%	RMC1/16 222JATP	J24185222		1-	A	F2
R 1034	CHIP RES.	560	1/16W	5%	RMC1/16 561JATP	J24185561		1	A	H1
R 1034	CHIP RES.	330	1/16W	5%	RMC1/16 331JATP	J24185331		2-	A	H1
R 1035	CHIP RES.	100	1/16W	5%	RMC1/16 101JATP	J24185101		1-	A	G2
R 1037	CHIP RES.	47	1/16W	5%	RMC1/16 470JATP	J24185470		1-	A	F2
R 1038	CHIP RES.	68	1/16W	5%	RMC1/16 680JATP	J24185680		1-	B	a1
R 1039	CHIP RES.	12k	1/16W	5%	RMC1/16 123JATP	J24185123		1-	B	c1
R 1040	CHIP RES.	100	1/16W	5%	RMC1/16 101JATP	J24185101		1-	A	H1
R 1041	CHIP RES.	2.2k	1/16W	5%	RMC1/16 222JATP	J24185222		1-	A	F2
R 1042	CHIP RES.	10k	1/16W	5%	RMC1/16 103JATP	J24185103		1-	A	E1
R 1043	CHIP RES.	47k	1/16W	5%	RMC1/16 473JATP	J24185473		1-	B	c1
R 1044	CHIP RES.	150k	1/16W	5%	RMC1/16 154JATP	J24185154		1	B	b1
R 1044	CHIP RES.	56k	1/16W	5%	RMC1/16 563JATP	J24185563		2-	B	b1
R 1045	CHIP RES.	150	1/16W	5%	RMC1/16 151JATP	J24185151		1-	B	a1
R 1046	CHIP RES.	470	1/16W	5%	RMC1/16 471JATP	J24185471		1-	A	F2
R 1047	CHIP RES.	1k	1/16W	5%	RMC1/16 102JATP	J24185102		1-	B	b1
R 1048	CHIP RES.	47	1/16W	5%	RMC1/16 470JATP	J24185470		1-	A	G2
R 1048	CHIP RES.	0	1/16W	5%	RMC1/16 000JATP	J24185000		2-	A	G2
R 1049	CHIP RES.	100	1/16W	5%	RMC1/16 101JATP	J24185101		1	B	a2
R 1049	CHIP RES.	220	1/16W	5%	RMC1/16 221JATP	J24185221		2-	B	a2
R 1050	CHIP RES.	150	1/16W	5%	RMC1/16 151JATP	J24185151		1-	A	F2
R 1051	CHIP RES.	100	1/16W	5%	RMC1/16 101JATP	J24185101		1	B	a2
R 1052	CHIP RES.	47	1/16W	5%	RMC1/16 470JATP	J24185470		1		
R 1053	CHIP RES.	150k	1/16W	5%	RMC1/16 154JATP	J24185154		1-	B	c1
R 1053	CHIP RES.	82k	1/16W	5%	RMC1/16 823JATP	J24185823		4-	B	c1
R 1054	CHIP RES.	100k	1/16W	5%	RMC1/16 104JATP	J24185104		1-	B	b1
R 1055	CHIP RES.	150	1/16W	5%	RMC1/16 151JATP	J24185151		1-	A	F1
R 1056	CHIP RES.	2.2k	1/16W	5%	RMC1/16 222JATP	J24185222		1	A	F1
R 1056	CHIP RES.	3.9k	1/16W	5%	RMC1/16 392JATP	J24185392		2-	A	F1
R 1057	CHIP RES.	2.2k	1/16W	5%	RMC1/16 222JATP	J24185222		1	A	E1
R 1057	CHIP RES.	100k	1/16W	5%	RMC1/16 104JATP	J24185104		2-	A	E1
R 1058	CHIP RES.	47k	1/16W	5%	RMC1/16 473JATP	J24185473		1-2	A	E1
R 1058	CHIP RES.	47k	1/16W	5%	RMC1/16 473JATP	J24185473		3-	A	E1
R 1059	CHIP RES.	100k	1/16W	5%	RMC1/16 104JATP	J24185104		1-2	B	c1

MAIN Unit

REF.	DESCRIPTION	VALUE	V/W	TOL.	MFR'S DESIG	VXSTD P/N	VERS.	LOT.	SIDE	LAY ADR
R 1059	CHIP RES.	100k	1/16W	5%	RMC1/16 104JATP	J24185104		3-	B	c1
R 1060	CHIP RES.	2.2k	1/16W	5%	RMC1/16 222JATP	J24185222		1-	A	F1
R 1061	CHIP RES.	1k	1/16W	5%	RMC1/16 102JATP	J24185102		1-	A	F1
R 1062	CHIP RES.	100k	1/16W	5%	RMC1/16 104JATP	J24185104		1-	B	a2
R 1063	CHIP RES.	150	1/16W	5%	RMC1/16 151JATP	J24185151		1-	B	c3
R 1064	CHIP RES.	150k	1/16W	5%	RMC1/16 154JATP	J24185154		1	B	c1
R 1064	CHIP RES.	220k	1/16W	5%	RMC1/16 224JATP	J24185224		2-	B	c1
R 1065	CHIP RES.	100k	1/16W	5%	RMC1/16 104JATP	J24185104		1-	B	a2
R 1066	CHIP RES.	100k	1/16W	5%	RMC1/16 104JATP	J24185104		1-	B	a3
R 1067	CHIP RES.	100k	1/16W	5%	RMC1/16 104JATP	J24185104		1-	B	a3
R 1069	CHIP RES.	100	1/16W	5%	RMC1/16 101JATP	J24185101		1	B	a3
R 1069	CHIP RES.	330	1/16W	5%	RMC1/16 331JATP	J24185331		2-	B	a3
R 1070	CHIP RES.	47k	1/16W	5%	RMC1/16 473JATP	J24185473		1	A	E1
R 1070	CHIP RES.	100k	1/16W	5%	RMC1/16 104JATP	J24185104		2-	A	E1
R 1071	CHIP RES.	100k	1/10W	5%	RMC1/10T 104J	J24205104		1-	B	c1
R 1072	CHIP RES.	68	1/16W	5%	RMC1/16 680JATP	J24185680		1-	B	b2
R 1073	CHIP RES.	4.7k	1/16W	5%	RMC1/16 472JATP	J24185472		1	B	d3
R 1073	CHIP RES.	470	1/16W	5%	RMC1/16 471JATP	J24185471		2-	B	d3
R 1074	CHIP RES.	560	1/16W	5%	RMC1/16 561JATP	J24185561		1	A	G3
R 1074	CHIP RES.	1k	1/16W	5%	RMC1/16 102JATP	J24185102		2-	A	G3
R 1075	CHIP RES.	150	1/16W	5%	RMC1/16 151JATP	J24185151		1	B	b1
R 1075	CHIP RES.	470	1/16W	5%	RMC1/16 471JATP	J24185471		2-	B	b1
R 1076	CHIP RES.	22k	1/16W	5%	RMC1/16 223JATP	J24185223		1	B	c1
R 1077	CHIP RES.	100	1/16W	5%	RMC1/16 101JATP	J24185101		1-	A	H3
R 1078	CHIP RES.	1k	1/16W	5%	RMC1/16 102JATP	J24185102		1-	B	d3
R 1079	CHIP RES.	100k	1/16W	5%	RMC1/16 104JATP	J24185104		1-	B	a2
R 1080	CHIP RES.	100k	1/16W	5%	RMC1/16 104JATP	J24185104		1-	B	a2
R 1081	CHIP RES.	100	1/16W	5%	RMC1/16 101JATP	J24185101		1-	A	G3
R 1082	CHIP RES.	100	1/16W	5%	RMC1/16 101JATP	J24185101		1-	B	d3
R 1083	CHIP RES.	47k	1/16W	5%	RMC1/16 473JATP	J24185473		1	A	F1
R 1083	CHIP RES.	1k	1/16W	5%	RMC1/16 102JATP	J24185102		2-	A	F1
R 1084	CHIP RES.	100	1/16W	5%	RMC1/16 101JATP	J24185101		1	B	a2
R 1084	CHIP RES.	470	1/16W	5%	RMC1/16 471JATP	J24185471		2-	B	a2
R 1085	CHIP RES.	560	1/16W	5%	RMC1/16 561JATP	J24185561		1	B	a2
R 1085	CHIP RES.	1k	1/16W	5%	RMC1/16 102JATP	J24185102		2-	B	a2
R 1086	CHIP RES.	100	1/16W	5%	RMC1/16 101JATP	J24185101		1-	A	G2
R 1087	CHIP RES.	150k	1/16W	5%	RMC1/16 154JATP	J24185154		1-	B	d4
R 1088	CHIP RES.	39	1/16W	5%	RMC1/16 390JATP	J24185390		1	B	b2
R 1088	CHIP RES.	10	1/16W	5%	RMC1/16 100JATP	J24185100		2-	B	b2
R 1089	CHIP RES.	100k	1/16W	5%	RMC1/16 104JATP	J24185104		1	B	d4
R 1089	CHIP RES.	100k	1/16W	5%	RMC1/16 104JATP	J24185104		2-	B	d4
R 1091	CHIP RES.	10	1/16W	5%	RMC1/16 100JATP	J24185100		1	B	b2
R 1091	CHIP RES.	150	1/16W	5%	RMC1/16 151JATP	J24185151		2-	B	b2
R 1092	CHIP RES.	150	1/16W	5%	RMC1/16 151JATP	J24185151		1		
R 1093	CHIP RES.	39	1/16W	5%	RMC1/16 390JATP	J24185390		1	B	b2
R 1093	CHIP RES.	10	1/16W	5%	RMC1/16 100JATP	J24185100		2-	B	b2
R 1095	CHIP RES.	100k	1/16W	5%	RMC1/16 104JATP	J24185104		1-	B	a3
R 1097	CHIP RES.	10k	1/16W	5%	RMC1/16 103JATP	J24185103		1-	B	e3
R 1099	CHIP RES.	100k	1/16W	5%	RMC1/16 104JATP	J24185104		1-	B	a3
R 1103	CHIP RES.	100	1/16W	5%	RMC1/16 101JATP	J24185101		1-	B	a3
R 1104	CHIP RES.	1k	1/16W	5%	RMC1/16 102JATP	J24185102		1-	A	G2
R 1105	CHIP RES.	1k	1/16W	5%	RMC1/16 102JATP	J24185102		1-	B	a3
R 1108	CHIP RES.	10k	1/16W	5%	RMC1/16 103JATP	J24185103		1-	B	b2
R 1109	CHIP RES.	220	1/16W	5%	RMC1/16 221JATP	J24185221		1-	B	e3
R 1110	CHIP RES.	220	1/16W	5%	RMC1/16 221JATP	J24185221		1	B	d3
R 1110	CHIP RES.	470	1/16W	5%	RMC1/16 471JATP	J24185471		2-	B	d3
R 1111	CHIP RES.	0	1/16W	5%	RMC1/16 000JATP	J24185000		1-	B	b2
R 1112	CHIP RES.	150	1/4W	5%	RMC1/4 151JATP	J24245151		1-	B	c2
R 1114	CHIP RES.	2.2k	1/16W	5%	RMC1/16 222JATP	J24185222		1	B	e3
R 1114	CHIP RES.	100k	1/16W	5%	RMC1/16 104JATP	J24185104		2-	B	e3
R 1115	CHIP RES.	150	1/10W	5%	RMC1/10T 151J	J24205151		1-	A	F2
R 1118	CHIP RES.	100	1/16W	5%	RMC1/16 101JATP	J24185101		1-	A	F3
R 1120	CHIP RES.	1k	1/16W	5%	RMC1/16 102JATP	J24185102		1-	B	d2
R 1121	CHIP RES.	1k	1/16W	5%	RMC1/16 102JATP	J24185102		1	B	e2
R 1121	CHIP RES.	2.7k	1/16W	5%	RMC1/16 272JATP	J24185272		2-	B	e2
R 1122	CHIP RES.	470	1/16W	5%	RMC1/16 471JATP	J24185471		1-	B	d2
R 1123	CHIP RES.	1k	1/16W	5%	RMC1/16 102JATP	J24185102		1-	B	b3
R 1124	CHIP RES.	1k	1/16W	5%	RMC1/16 102JATP	J24185102		1	B	c3

REF.	DESCRIPTION	VALUE	V/W	TOL.	MFR'S DESIG	VXSTD P/N	VERS.	LOT.	SIDE	LAY ADR
R 1124	CHIP RES.	1.5k	1/16W	5%	RMC1/16 152JATP	J24185152		2-	B	c3
R 1125	CHIP RES.	1k	1/16W	5%	RMC1/16 102JATP	J24185102		1	B	c3
R 1125	CHIP RES.	1.5k	1/16W	5%	RMC1/16 152JATP	J24185152		2-	B	c3
R 1126	CHIP RES.	100k	1/16W	5%	RMC1/16 104JATP	J24185104		1-	B	b3
R 1127	CHIP RES.	2.2k	1/16W	5%	RMC1/16 222JATP	J24185222		1	B	e2
R 1127	CHIP RES.	22k	1/16W	5%	RMC1/16 223JATP	J24185223		2-	B	e2
R 1128	CHIP RES.	10k	1/16W	5%	RMC1/16 103JATP	J24185103		1-	B	e2
R 1129	CHIP RES.	150k	1/16W	5%	RMC1/16 154JATP	J24185154		1-	B	b3
R 1130	CHIP RES.	4.7k	1/16W	5%	RMC1/16 472JATP	J24185472		1-	B	c2
R 1131	CHIP RES.	150	1/16W	5%	RMC1/16 151JATP	J24185151		1-	B	c2
R 1132	CHIP RES.	47	1/10W	5%	RMC1/10T 470J	J24205470		1-	B	b3
R 1133	CHIP RES.	4.7k	1/16W	5%	RMC1/16 472JATP	J24185472		1-	B	a3
R 1134	CHIP RES.	0	1/16W	5%	RMC1/16 000JATP	J24185000		1-	B	b2
R 1135	CHIP RES.	150	1/16W	5%	RMC1/16 151JATP	J24185151		1-	B	b2
R 1136	CHIP RES.	82k	1/16W	5%	RMC1/16 823JATP	J24185823		1	B	c4
R 1136	CHIP RES.	68k	1/16W	5%	RMC1/16 683JATP	J24185683		2-	B	c4
R 1137	CHIP RES.	1M	1/16W	5%	RMC1/16 105JATP	J24185105		1-	B	d2
R 1138	CHIP RES.	100k	1/16W	5%	RMC1/16 104JATP	J24185104		1-	B	c4
R 1139	CHIP RES.	1.5k	1/16W	5%	RMC1/16 152JATP	J24185152		1	B	e2
R 1139	CHIP RES.	12k	1/16W	5%	RMC1/16 123JATP	J24185123		2-	B	e2
R 1140	CHIP RES.	4.7k	1/16W	5%	RMC1/16 472JATP	J24185472		1-	B	c1
R 1141	CHIP RES.	470	1/16W	5%	RMC1/16 471JATP	J24185471		1-	A	F3
R 1142	CHIP RES.	470	1/16W	5%	RMC1/16 471JATP	J24185471		1-	A	F3
R 1143	CHIP RES.	100k	1/16W	5%	RMC1/16 104JATP	J24185104		1-	B	e2
R 1144	CHIP RES.	22k	1/16W	5%	RMC1/16 223JATP	J24185223		1	B	c4
R 1144	CHIP RES.	6.8k	1/16W	5%	RMC1/16 682JATP	J24185682		2-3	B	c4
R 1144	CHIP RES.	6.8k	1/16W	5%	RMC1/16 682JATP	J24185682		4-	B	c4
R 1145	CHIP RES.	150	1/16W	5%	RMC1/16 151JATP	J24185151		1-	A	E2
R 1146	CHIP RES.	1k	1/16W	5%	RMC1/16 102JATP	J24185102		1-	B	d1
R 1147	CHIP RES.	1k	1/16W	5%	RMC1/16 102JATP	J24185102		1-	B	c4
R 1148	CHIP RES.	10k	1/16W	5%	RMC1/16 103JATP	J24185103		1	A	B3
R 1148	CHIP RES.	1k	1/16W	5%	RMC1/16 102JATP	J24185102		2-	A	B3
R 1149	CHIP RES.	10k	1/16W	5%	RMC1/16 103JATP	J24185103		1-	B	f3
R 1150	CHIP RES.	10k	1/16W	5%	RMC1/16 103JATP	J24185103		1	B	c4
R 1150	CHIP RES.	2.2k	1/16W	5%	RMC1/16 222JATP	J24185222		2-	B	c4
R 1151	CHIP RES.	4.7k	1/16W	5%	RMC1/16 472JATP	J24185472		1		
R 1152	CHIP RES.	150	1/16W	5%	RMC1/16 151JATP	J24185151		1	A	E2
R 1152	CHIP RES.	4.7k	1/16W	5%	RMC1/16 472JATP	J24185472		2-	A	E2
R 1153	CHIP RES.	100	1/16W	5%	RMC1/16 101JATP	J24185101		1-	B	b3
R 1154	CHIP RES.	10k	1/16W	5%	RMC1/16 103JATP	J24185103		1	A	D2
R 1154	CHIP RES.	2.7k	1/16W	5%	RMC1/16 272JATP	J24185272		2-	A	D2
R 1155	CHIP RES.	150	1/16W	5%	RMC1/16 151JATP	J24185151		1	B	c4
R 1155	CHIP RES.	5.6k	1/16W	5%	RMC1/16 562JATP	J24185562		2-	B	c4
R 1156	CHIP RES.	4.7k	1/16W	5%	RMC1/16 472JATP	J24185472		1-	B	a3
R 1157	CHIP RES.	1M	1/16W	5%	RMC1/16 105JATP	J24185105		1-	B	d2
R 1158	CHIP RES.	150	1/16W	5%	RMC1/16 151JATP	J24185151		1-	B	b3
R 1159	CHIP RES.	100	1/16W	5%	RMC1/16 101JATP	J24185101		1-	B	c4
R 1160	CHIP RES.	150	1/16W	5%	RMC1/16 151JATP	J24185151		1-	B	b3
R 1161	CHIP RES.	22k	1/16W	5%	RMC1/16 223JATP	J24185223		1	B	c4
R 1161	CHIP RES.	5.6k	1/16W	5%	RMC1/16 562JATP	J24185562		2-	B	c4
R 1162	CHIP RES.	1k	1/16W	5%	RMC1/16 102JATP	J24185102		1-	B	d2
R 1163	CHIP RES.	1M	1/16W	5%	RMC1/16 105JATP	J24185105		1		
R 1164	CHIP RES.	10k	1/16W	5%	RMC1/16 103JATP	J24185103		1	B	b4
R 1164	CHIP RES.	10k	1/16W	5%	RMC1/16 103JATP	J24185103		2-	B	b4
R 1165	CHIP RES.	100	1/16W	5%	RMC1/16 101JATP	J24185101		1-	B	d4
R 1166	CHIP RES.	3.3k	1/16W	5%	RMC1/16 332JATP	J24185332		1	B	c5
R 1166	CHIP RES.	1.5k	1/16W	5%	RMC1/16 152JATP	J24185152		2-	B	c5
R 1167	CHIP RES.	2.2k	1/16W	5%	RMC1/16 222JATP	J24185222		1-	A	G3
R 1168	CHIP RES.	10k	1/16W	5%	RMC1/16 103JATP	J24185103		1-	B	c5
R 1169	CHIP RES.	10k	1/16W	5%	RMC1/16 103JATP	J24185103		1	B	a3
R 1169	CHIP RES.	0	1/16W	5%	RMC1/16 000JATP	J24185000		2-	B	a3
R 1170	CHIP RES.	4.7k	1/16W	5%	RMC1/16 472JATP	J24185472		1-	B	d3
R 1171	CHIP RES.	150	1/16W	5%	RMC1/16 151JATP	J24185151		1	B	c4
R 1171	CHIP RES.	220	1/10W	5%	RMC1/10T 221J	J24205221		2-	B	c4
R 1172	CHIP RES.	100	1/16W	5%	RMC1/16 101JATP	J24185101		1-	A	G4
R 1173	CHIP RES.	1M	1/16W	5%	RMC1/16 105JATP	J24185105		1		
R 1174	CHIP RES.	100k	1/16W	5%	RMC1/16 104JATP	J24185104		1	A	G4
R 1174	CHIP RES.	47k	1/16W	5%	RMC1/16 473JATP	J24185473		2-	A	G4

MAIN Unit

REF.	DESCRIPTION	VALUE	V/W	TOL.	MFR'S DESIG	VXSTD P/N	VERS.	LOT.	SIDE	LAY ADR
R 1175	CHIP RES.	150	1/16W	5%	RMC1/16 151JATP	J24185151		1-	A	E3
R 1176	CHIP RES.	560k	1/16W	5%	RMC1/16 564JATP	J24185564		1-	A	G5
R 1177	CHIP RES.	330	1/16W	5%	RMC1/16 331JATP	J24185331		1-	A	F4
R 1178	CHIP RES.	33k	1/16W	5%	RMC1/16 333JATP	J24185333		1-	B	a4
R 1179	CHIP RES.	100k	1/16W	5%	RMC1/16 104JATP	J24185104		1-	B	a4
R 1179	CHIP RES.	82k	1/16W	5%	RMC1/16 823JATP	J24185823		4-	B	a4
R 1180	CHIP RES.	150k	1/16W	5%	RMC1/16 154JATP	J24185154		1-	B	a4
R 1181	CHIP RES.	10k	1/16W	5%	RMC1/16 103JATP	J24185103		1-	B	b5
R 1182	CHIP RES.	100	1/16W	5%	RMC1/16 101JATP	J24185101		1-	B	b4
R 1183	CHIP RES.	39k	1/16W	5%	RMC1/16 393JATP	J24185393		1-	B	b5
R 1184	CHIP RES.	150	1/16W	5%	RMC1/16 151JATP	J24185151		1-	B	a5
R 1185	CHIP RES.	22k	1/16W	5%	RMC1/16 223JATP	J24185223		1-	B	a5
R 1186	CHIP RES.	150	1/16W	5%	RMC1/16 151JATP	J24185151		1	B	b4
R 1186	CHIP RES.	100	1/16W	5%	RMC1/16 101JATP	J24185101		2-	B	b4
R 1187	CHIP RES.	15k	1/16W	5%	RMC1/16 153JATP	J24185153		1-	A	G4
R 1188	CHIP RES.	100	1/16W	5%	RMC1/16 101JATP	J24185101		1-	A	G4
R 1189	CHIP RES.	100	1/16W	5%	RMC1/16 101JATP	J24185101		1-	A	G4
R 1190	CHIP RES.	150	1/16W	5%	RMC1/16 151JATP	J24185151		1-	B	f3
R 1191	CHIP RES.	470	1/16W	5%	RMC1/16 471JATP	J24185471		1-	B	a5
R 1192	CHIP RES.	150	1/16W	5%	RMC1/16 151JATP	J24185151		1-	B	a4
R 1193	CHIP RES.	150	1/16W	5%	RMC1/16 151JATP	J24185151		1-	B	f2
R 1194	CHIP RES.	100	1/16W	5%	RMC1/16 101JATP	J24185101		1	A	C3
R 1194	CHIP RES.	220	1/16W	5%	RMC1/16 221JATP	J24185221		2-	A	C3
R 1195	CHIP RES.	100	1/10W	5%	RMC1/10T 101J	J24205101		1-	A	A3
R 1196	CHIP RES.	10k	1/16W	5%	RMC1/16 103JATP	J24185103		1	B	f2
R 1196	CHIP RES.	4.7k	1/16W	5%	RMC1/16 472JATP	J24185472		2-	B	f2
R 1197	CHIP RES.	220	1/16W	5%	RMC1/16 221JATP	J24185221		1	B	f3
R 1197	CHIP RES.	390	1/16W	5%	RMC1/16 391JATP	J24185391		2-	B	f3
R 1198	CHIP RES.	10k	1/16W	5%	RMC1/16 103JATP	J24185103		1-	B	b4
R 1199	CHIP RES.	1k	1/16W	5%	RMC1/16 102JATP	J24185102		1-	B	f2
R 1200	CHIP RES.	100	1/16W	5%	RMC1/16 101JATP	J24185101		1-	A	G5
R 1201	CHIP RES.	10k	1/16W	5%	RMC1/16 103JATP	J24185103		1		
R 1202	CHIP RES.	100	1/16W	5%	RMC1/16 101JATP	J24185101		1-	B	b4
R 1203	CHIP RES.	330	1/16W	5%	RMC1/16 331JATP	J24185331		1-	B	h2
R 1204	CHIP RES.	330	1/16W	5%	RMC1/16 331JATP	J24185331		1-	B	h2
R 1205	CHIP RES.	330	1/16W	5%	RMC1/16 331JATP	J24185331		1-	B	h3
R 1206	CHIP RES.	330	1/16W	5%	RMC1/16 331JATP	J24185331		1-	B	g3
R 1207	CHIP RES.	10k	1/16W	5%	RMC1/16 103JATP	J24185103		1	B	g3
R 1207	CHIP RES.	68k	1/16W	5%	RMC1/16 683JATP	J24185683		2-	B	g3
R 1208	CHIP RES.	470	1/16W	5%	RMC1/16 471JATP	J24185471		1-	B	f3
R 1209	CHIP RES.	150k	1/16W	5%	RMC1/16 154JATP	J24185154		1	B	e3
R 1209	CHIP RES.	120k	1/16W	5%	RMC1/16 124JATP	J24185124		2-	B	e3
R 1210	CHIP RES.	10k	1/16W	5%	RMC1/16 103JATP	J24185103		1-	B	h2
R 1211	CHIP RES.	10k	1/16W	5%	RMC1/16 103JATP	J24185103		1-	B	h2
R 1212	CHIP RES.	10k	1/16W	5%	RMC1/16 103JATP	J24185103		1		
R 1213	CHIP RES.	1k	1/16W	5%	RMC1/16 102JATP	J24185102		1-	A	C2
R 1214	CHIP RES.	330	1/16W	5%	RMC1/16 331JATP	J24185331		1-	B	b4
R 1215	CHIP RES.	680	1/16W	5%	RMC1/16 681JATP	J24185681		1-	B	e3
R 1216	CHIP RES.	100k	1/16W	5%	RMC1/16 104JATP	J24185104		1	B	f3
R 1216	CHIP RES.	82k	1/16W	5%	RMC1/16 823JATP	J24185823		2-	B	f3
R 1216	CHIP RES.	68k	1/16W	5%	RMC1/16 683JATP	J24185683		4-	B	f3
R 1217	CHIP RES.	100	1/16W	5%	RMC1/16 101JATP	J24185101		1-	B	e3
R 1218	CHIP RES.	10k	1/16W	5%	RMC1/16 103JATP	J24185103		1-	B	g3
R 1219	CHIP RES.	100	1/16W	5%	RMC1/16 101JATP	J24185101		1-	B	e3
R 1220	CHIP RES.	10k	1/16W	5%	RMC1/16 103JATP	J24185103		1-	B	h2
R 1221	CHIP RES.	10k	1/16W	5%	RMC1/16 103JATP	J24185103		1-	B	h2
R 1222	CHIP RES.	15k	1/16W	5%	RMC1/16 153JATP	J24185153		1-	B	e3
R 1223	CHIP RES.	560	1/16W	5%	RMC1/16 561JATP	J24185561		1-	B	c5
R 1224	CHIP RES.	150	1/16W	5%	RMC1/16 151JATP	J24185151		1-	B	f2
R 1225	CHIP RES.	1k	1/16W	5%	RMC1/16 102JATP	J24185102		1-	B	f2
R 1226	CHIP RES.	470	1/16W	5%	RMC1/16 471JATP	J24185471		1-	B	b5
R 1227	CHIP RES.	100	1/16W	5%	RMC1/16 101JATP	J24185101		1-	A	C3
R 1228	CHIP RES.	10k	1/16W	5%	RMC1/16 103JATP	J24185103		1-	B	g2
R 1229	CHIP RES.	10k	1/16W	5%	RMC1/16 103JATP	J24185103		1-	B	g2
R 1230	CHIP RES.	33k	1/16W	5%	RMC1/16 333JATP	J24185333		1	A	C2
R 1230	CHIP RES.	82k	1/16W	5%	RMC1/16 823JATP	J24185823		2-	A	C2
R 1230	CHIP RES.	47k	1/16W	5%	RMC1/16 473JATP	J24185473		4-	A	C2
R 1231	CHIP RES.	10k	1/16W	5%	RMC1/16 103JATP	J24185103		1-	A	C2

REF.	DESCRIPTION	VALUE	V/W	TOL.	MFR'S DESIG	VXSTD P/N	VERS.	LOT.	SIDE	LAY ADR
R 1232	CHIP RES.	10k	1/16W	5%	RMC1/16 103JATP	J24185103		1-	B	g3
R 1233	CHIP RES.	10k	1/16W	5%	RMC1/16 103JATP	J24185103		1		
R 1234	CHIP RES.	10k	1/16W	5%	RMC1/16 103JATP	J24185103		1		
R 1235	CHIP RES.	10k	1/16W	5%	RMC1/16 103JATP	J24185103		1	B	c4
R 1235	CHIP RES.	100k	1/16W	5%	RMC1/16 104JATP	J24185104		2-	B	c4
R 1236	CHIP RES.	100	1/16W	5%	RMC1/16 101JATP	J24185101		1-	B	e3
R 1237	CHIP RES.	10k	1/16W	5%	RMC1/16 103JATP	J24185103		1-	B	g3
R 1238	CHIP RES.	150	1/16W	5%	RMC1/16 151JATP	J24185151		1-	B	e2
R 1239	CHIP RES.	47k	1/16W	5%	RMC1/16 473JATP	J24185473		1	B	c4
R 1239	CHIP RES.	1k	1/16W	5%	RMC1/16 102JATP	J24185102		2-	B	c4
R 1240	CHIP RES.	15k	1/16W	5%	RMC1/16 153JATP	J24185153		1-	B	e2
R 1241	CHIP RES.	100k	1/16W	5%	RMC1/16 104JATP	J24185104		1-	B	d5
R 1242	CHIP RES.	1k	1/16W	5%	RMC1/16 102JATP	J24185102		1-	B	c5
R 1243	CHIP RES.	100	1/16W	5%	RMC1/16 101JATP	J24185101		1-	A	C2
R 1244	CHIP RES.	150	1/16W	5%	RMC1/16 151JATP	J24185151		1-	A	E5
R 1245	CHIP RES.	10k	1/16W	5%	RMC1/16 103JATP	J24185103		1-	B	d5
R 1246	CHIP RES.	33k	1/16W	5%	RMC1/16 333JATP	J24185333		1-	A	C2
R 1247	CHIP RES.	10k	1/16W	5%	RMC1/16 103JATP	J24185103		1		
R 1248	CHIP RES.	10k	1/16W	5%	RMC1/16 103JATP	J24185103		1	B	h3
R 1248	CHIP RES.	8.2k	1/16W	5%	RMC1/16 822JATP	J24185822		2-	B	h3
R 1249	CHIP RES.	10k	1/16W	5%	RMC1/16 103JATP	J24185103		1		
R 1250	CHIP RES.	10k	1/16W	5%	RMC1/16 103JATP	J24185103		1	A	A2
R 1250	CHIP RES.	12k	1/16W	5%	RMC1/16 123JATP	J24185123		2-	A	A2
R 1251	CHIP RES.	10k	1/16W	5%	RMC1/16 103JATP	J24185103		1-	A	C2
R 1252	CHIP RES.	100	1/16W	5%	RMC1/16 101JATP	J24185101		1-	B	e2
R 1253	CHIP RES.	150	1/16W	5%	RMC1/16 151JATP	J24185151		1-	B	e2
R 1254	CHIP RES.	10k	1/16W	5%	RMC1/16 103JATP	J24185103		1	B	f3
R 1254	CHIP RES.	18k	1/16W	5%	RMC1/16 183JATP	J24185183		2-	B	f3
R 1255	CHIP RES.	12k	1/16W	5%	RMC1/16 123JATP	J24185123		1-	B	f3
R 1256	CHIP RES.	10k	1/16W	5%	RMC1/16 103JATP	J24185103		1-	B	e2
R 1257	CHIP RES.	10k	1/16W	5%	RMC1/16 103JATP	J24185103		1-	B	f3
R 1258	CHIP RES.	10	1/16W	5%	RMC1/16 100JATP	J24185100		1-	B	f3
R 1259	CHIP RES.	100	1/16W	5%	RMC1/16 101JATP	J24185101		1-	A	C2
R 1260	CHIP RES.	12k	1/16W	5%	RMC1/16 123JATP	J24185123		1-	B	f3
R 1261	CHIP RES.	2.2k	1/10W	5%	RMC1/10T 222J	J24205222		1-	B	f2
R 1262	CHIP RES.	150k	1/16W	5%	RMC1/16 154JATP	J24185154		1	B	f3
R 1262	CHIP RES.	10k	1/16W	5%	RMC1/16 103JATP	J24185103		2-	B	f3
R 1263	CHIP RES.	10k	1/16W	5%	RMC1/16 103JATP	J24185103		1	B	f3
R 1263	CHIP RES.	1M	1/16W	5%	RMC1/16 105JATP	J24185105		2-	B	f3
R 1264	CHIP RES.	3.3M	1/16W	5%	RMC1/16 335JATP	J24185335		1	B	f3
R 1264	CHIP RES.	220k	1/16W	5%	RMC1/16 224JATP	J24185224		2-	B	f3
R 1265	CHIP RES.	10k	1/16W	5%	RMC1/16 103JATP	J24185103		1-	A	A2
R 1266	CHIP RES.	100k	1/16W	5%	RMC1/16 104JATP	J24185104		1-	B	e2
R 1267	CHIP RES.	10	1/16W	5%	RMC1/16 100JATP	J24185100		1-	B	f3
R 1268	CHIP RES.	220k	1/16W	5%	RMC1/16 224JATP	J24185224		1	B	g2
R 1268	CHIP RES.	330k	1/16W	5%	RMC1/16 334JATP	J24185334		2-	B	g2
R 1269	CHIP RES.	10k	1/16W	5%	RMC1/16 103JATP	J24185103		1-	B	f3
R 1270	CHIP RES.	10k	1/16W	5%	RMC1/16 103JATP	J24185103		1		
R 1271	CHIP RES.	10	1/16W	5%	RMC1/16 100JATP	J24185100		1		
R 1272	CHIP RES.	10	1/16W	5%	RMC1/16 100JATP	J24185100		1-	B	f3
R 1273	CHIP RES.	1k	1/16W	5%	RMC1/16 102JATP	J24185102		1-	B	e2
R 1274	CHIP RES.	1k	1/16W	5%	RMC1/16 102JATP	J24185102		1	B	c4
R 1274	CHIP RES.	3.3k	1/16W	5%	RMC1/16 332JATP	J24185332		2-	B	c4
R 1275	CHIP RES.	10k	1/16W	5%	RMC1/16 103JATP	J24185103		1-	B	g2
R 1276	CHIP RES.	10k	1/16W	5%	RMC1/16 103JATP	J24185103		1-	B	f3
R 1277	CHIP RES.	220	1/10W	5%	RMC1/10T 221J	J24205221		1-	B	e4
R 1278	CHIP RES.	4.7k	1/16W	5%	RMC1/16 472JATP	J24185472		1-	B	f3
R 1279	CHIP RES.	22k	1/16W	5%	RMC1/16 223JATP	J24185223		1	B	f4
R 1279	CHIP RES.	15k	1/16W	5%	RMC1/16 153JATP	J24185153		2-	B	f4
R 1280	CHIP RES.	10k	1/16W	5%	RMC1/16 103JATP	J24185103		1	A	B2
R 1280	CHIP RES.	39k	1/16W	5%	RMC1/16 393JATP	J24185393		2-	A	B2
R 1281	CHIP RES.	470	1/16W	5%	RMC1/16 471JATP	J24185471		1-	B	e4
R 1282	CHIP RES.	10k	1/16W	5%	RMC1/16 103JATP	J24185103		1-	B	g3
R 1283	CHIP RES.	220k	1/16W	5%	RMC1/16 224JATP	J24185224		1	B	g2
R 1283	CHIP RES.	5.6k	1/16W	5%	RMC1/16 562JATP	J24185562		2-	B	g2
R 1284	CHIP RES.	1k	1/16W	5%	RMC1/16 102JATP	J24185102		1-	B	b4
R 1285	CHIP RES.	100	1/16W	5%	RMC1/16 101JATP	J24185101		1	B	e5
R 1285	CHIP RES.	150	1/16W	5%	RMC1/16 151JATP	J24185151		2-	B	e5

MAIN Unit

REF.	DESCRIPTION	VALUE	V/W	TOL.	MFR'S DESIG	VXSTD P/N	VERS.	LOT.	SIDE	LAY ADR
R 1286	CHIP RES.	100	1/16W	5%	RMC1/16 101JATP	J24185101		1	B	d5
R 1286	CHIP RES.	150	1/16W	5%	RMC1/16 151JATP	J24185151		2-	B	d5
R 1287	CHIP RES.	100	1/16W	5%	RMC1/16 101JATP	J24185101		1	B	e5
R 1287	CHIP RES.	150	1/16W	5%	RMC1/16 151JATP	J24185151		2-	B	e5
R 1288	CHIP RES.	100	1/16W	5%	RMC1/16 101JATP	J24185101		1-	A	C5
R 1289	CHIP RES.	100	1/16W	5%	RMC1/16 101JATP	J24185101		1-	B	e2
R 1290	CHIP RES.	10k	1/16W	5%	RMC1/16 103JATP	J24185103		1-	B	g2
R 1291	CHIP RES.	10k	1/16W	5%	RMC1/16 103JATP	J24185103		1-	A	A2
R 1292	CHIP RES.	10k	1/16W	5%	RMC1/16 103JATP	J24185103		1-	B	g2
R 1293	CHIP RES.	220	1/10W	5%	RMC1/10T 221J	J24205221		1-	B	e4
R 1294	CHIP RES.	10k	1/16W	5%	RMC1/16 103JATP	J24185103		1-	A	C2
R 1295	CHIP RES.	100	1/16W	5%	RMC1/16 101JATP	J24185101		1-	B	e1
R 1297	CHIP RES.	10k	1/16W	5%	RMC1/16 103JATP	J24185103		1-	A	A2
R 1298	CHIP RES.	22k	1/16W	5%	RMC1/16 223JATP	J24185223		1-	B	e1
R 1299	CHIP RES.	10k	1/16W	5%	RMC1/16 103JATP	J24185103		1-	A	A2
R 1300	CHIP RES.	1k	1/16W	5%	RMC1/16 102JATP	J24185102		1	B	g3
R 1300	CHIP RES.	22k	1/16W	5%	RMC1/16 223JATP	J24185223		2-	B	g3
R 1301	CHIP RES.	10k	1/16W	5%	RMC1/16 103JATP	J24185103		1-	B	g2
R 1302	CHIP RES.	47k	1/16W	5%	RMC1/16 473JATP	J24185473		1		
R 1303	CHIP RES.	100	1/16W	5%	RMC1/16 101JATP	J24185101		1-	B	f5
R 1304	CHIP RES.	100	1/16W	5%	RMC1/16 101JATP	J24185101		1-	A	C5
R 1305	CHIP RES.	100	1/16W	5%	RMC1/16 101JATP	J24185101		1-	B	e5
R 1306	CHIP RES.	100	1/16W	5%	RMC1/16 101JATP	J24185101		1		
R 1307	CHIP RES.	1.8k	1/16W	5%	RMC1/16 182JATP	J24185182		1-	B	b4
R 1308	CHIP RES.	10k	1/16W	5%	RMC1/16 103JATP	J24185103		1	B	g1
R 1308	CHIP RES.	100k	1/16W	5%	RMC1/16 104JATP	J24185104		2-	B	g1
R 1309	CHIP RES.	560k	1/16W	5%	RMC1/16 564JATP	J24185564		1-	A	F4
R 1310	CHIP RES.	22k	1/16W	5%	RMC1/16 223JATP	J24185223		1-	B	c4
R 1311	CHIP RES.	10k	1/16W	5%	RMC1/16 103JATP	J24185103		1-	B	g1
R 1312	CHIP RES.	1M	1/16W	5%	RMC1/16 105JATP	J24185105		1-	B	e2
R 1313	CHIP RES.	10k	1/16W	5%	RMC1/16 103JATP	J24185103		1	B	g3
R 1313	CHIP RES.	3.3k	1/16W	5%	RMC1/16 332JATP	J24185332		2-	B	g3
R 1313	CHIP RES.	5.6k	1/16W	5%	RMC1/16 562JATP	J24185562		5-	B	g3
R 1314	CHIP RES.	1k	1/16W	5%	RMC1/16 102JATP	J24185102		1-	B	e2
R 1315	CHIP RES.	1.8k	1/16W	5%	RMC1/16 182JATP	J24185182		1-	B	c4
R 1316	CHIP RES.	10k	1/16W	5%	RMC1/16 103JATP	J24185103		1	B	g1
R 1316	CHIP RES.	100k	1/16W	5%	RMC1/16 104JATP	J24185104		2-	B	g1
R 1317	CHIP RES.	47k	1/16W	5%	RMC1/16 473JATP	J24185473		1	B	e1
R 1317	CHIP RES.	82k	1/16W	5%	RMC1/16 823JATP	J24185823		2-	B	e1
R 1318	CHIP RES.	10k	1/16W	5%	RMC1/16 103JATP	J24185103		1-	A	C2
R 1319	CHIP RES.	10k	1/16W	5%	RMC1/16 103JATP	J24185103		1-	A	D1
R 1320	CHIP RES.	10k	1/16W	5%	RMC1/16 103JATP	J24185103		1	A	C1
R 1320	CHIP RES.	1M	1/16W	5%	RMC1/16 105JATP	J24185105		2-	A	C1
R 1321	CHIP RES.	10k	1/16W	5%	RMC1/16 103JATP	J24185103		1	A	D1
R 1321	CHIP RES.	270k	1/16W	5%	RMC1/16 274JATP	J24185274		2-	A	D1
R 1322	CHIP RES.	150k	1/16W	5%	RMC1/16 154JATP	J24185154		1		
R 1323	CHIP RES.	100k	1/16W	5%	RMC1/16 104JATP	J24185104		1	B	f2
R 1323	CHIP RES.	33k	1/16W	5%	RMC1/16 333JATP	J24185333		2-	B	f2
R 1324	CHIP RES.	150k	1/16W	5%	RMC1/16 154JATP	J24185154		1-	B	f1
R 1325	CHIP RES.	220k	1/16W	5%	RMC1/16 224JATP	J24185224		1	B	g3
R 1325	CHIP RES.	47k	1/16W	5%	RMC1/16 473JATP	J24185473		2-	B	g3
R 1326	CHIP RES.	10k	1/16W	5%	RMC1/16 103JATP	J24185103		1	B	e2
R 1326	CHIP RES.	10k	1/16W	5%	RMC1/16 103JATP	J24185103		2-	B	e2
R 1327	CHIP RES.	10k	1/16W	5%	RMC1/16 103JATP	J24185103		1	A	D1
R 1327	CHIP RES.	6.8k	1/16W	5%	RMC1/16 682JATP	J24185682		2-	A	D1
R 1328	CHIP RES.	10k	1/16W	5%	RMC1/16 103JATP	J24185103		1-	B	d1
R 1329	CHIP RES.	10k	1/16W	5%	RMC1/16 103JATP	J24185103		1-	A	D1
R 1330	CHIP RES.	10k	1/16W	5%	RMC1/16 103JATP	J24185103		1-	B	e1
R 1331	CHIP RES.	10k	1/16W	5%	RMC1/16 103JATP	J24185103		1-	A	D2
R 1332	CHIP RES.	10k	1/16W	5%	RMC1/16 103JATP	J24185103		1-	B	g3
R 1333	CHIP RES.	10	1/16W	5%	RMC1/16 100JATP	J24185100		1-	B	g3
R 1334	CHIP RES.	10k	1/16W	5%	RMC1/16 103JATP	J24185103		1	A	A4
R 1334	CHIP RES.	10k	1/10W	5%	RMC1/10T 103J	J24205103		2-	A	A4
R 1335	CHIP RES.	10k	1/16W	5%	RMC1/16 103JATP	J24185103		1	A	A4
R 1335	CHIP RES.	10k	1/10W	5%	RMC1/10T 103J	J24205103		2-	A	A4
R 1336	CHIP RES.	150k	1/16W	5%	RMC1/16 154JATP	J24185154		1	B	e1
R 1336	CHIP RES.	270k	1/16W	5%	RMC1/16 274JATP	J24185274		2-	B	e1
R 1337	CHIP RES.	10k	1/16W	5%	RMC1/16 103JATP	J24185103		1-	A	C1

REF.	DESCRIPTION	VALUE	V/W	TOL.	MFR'S DESIG	VXSTD P/N	VERS.	LOT.	SIDE	LAY ADR
R 1338	CHIP RES.	10k	1/16W	5%	RMC1/16 103JATP	J24185103		1	A	D1
R 1338	CHIP RES.	12k	1/16W	5%	RMC1/16 123JATP	J24185123		2-	A	D1
R 1339	CHIP RES.	220	1/2W	5%	RMC1/2 221JCTP	J24275221		1-	B	g1
R 1339	CHIP RES.	150	1/2W	5%	RMC1/2 151JCTP	J24275151		2-	B	g1
R 1340	CHIP RES.	2.2	1/10W	5%	RMC1/10T 2R2J	J24205229		1-	B	g1
R 1341	CHIP RES.	10k	1/16W	5%	RMC1/16 103JATP	J24185103		1-	A	C2
R 1342	CHIP RES.	10k	1/16W	5%	RMC1/16 103JATP	J24185103		1-	A	C1
R 1342	CHIP RES.	1M	1/16W	5%	RMC1/16 105JATP	J24185105		2-	A	C1
R 1343	CHIP RES.	22k	1/16W	5%	RMC1/16 223JATP	J24185223		1	B	g3
R 1343	CHIP RES.	15k	1/16W	5%	RMC1/16 153JATP	J24185153		2-	B	g3
R 1344	CHIP RES.	2.2k	1/16W	5%	RMC1/16 222JATP	J24185222		1		
R 1345	CHIP RES.	4.7k	1/16W	5%	RMC1/16 472JATP	J24185472		1	B	e1
R 1345	CHIP RES.	0	1/16W	5%	RMC1/16 000JATP	J24185000		2-	B	e1
R 1346	CHIP RES.	5.6k	1/16W	5%	RMC1/16 562JATP	J24185562		1-	B	e1
R 1347	CHIP RES.	1	1/10W	5%	RMC1/10T 1R0J	J24205010		1-	B	g1
R 1348	CHIP RES.	1k	1/16W	5%	RMC1/16 102JATP	J24185102		1-	B	h4
R 1349	CHIP RES.	100k	1/10W	5%	RMC1/10T 104J	J24205104		1	B	f3
R 1349	CHIP RES.	33k	1/16W	5%	RMC1/16 333JATP	J24185333		2-	B	f3
R 1350	CHIP RES.	150k	1/16W	5%	RMC1/16 154JATP	J24185154		1-	A	B2
R 1351	CHIP RES.	330	1/16W	5%	RMC1/16 331JATP	J24185331		1-	B	g4
R 1352	CHIP RES.	330	1/16W	5%	RMC1/16 331JATP	J24185331		1-	A	B4
R 1353	CHIP RES.	330	1/16W	5%	RMC1/16 331JATP	J24185331		1-	A	B4
R 1354	CHIP RES.	330	1/16W	5%	RMC1/16 331JATP	J24185331		1		
R 1355	CHIP RES.	330	1/16W	5%	RMC1/16 331JATP	J24185331		1-	B	g4
R 1356	CHIP RES.	330	1/16W	5%	RMC1/16 331JATP	J24185331		1-	B	g4
R 1357	CHIP RES.	330	1/16W	5%	RMC1/16 331JATP	J24185331		1-	B	g4
R 1358	CHIP RES.	100k	1/16W	5%	RMC1/16 104JATP	J24185104		1-	A	A2
R 1359	CHIP RES.	10k	1/16W	5%	RMC1/16 103JATP	J24185103		1	B	g1
R 1359	CHIP RES.	150k	1/16W	5%	RMC1/16 154JATP	J24185154		2-	B	g1
R 1361	CHIP RES.	10k	1/16W	5%	RMC1/16 103JATP	J24185103		1	B	f4
R 1362	CHIP RES.	10k	1/16W	5%	RMC1/16 103JATP	J24185103		1-	B	f4
R 1363	CHIP RES.	10k	1/16W	5%	RMC1/16 103JATP	J24185103		1-	A	B4
R 1364	CHIP RES.	1k	1/16W	5%	RMC1/16 102JATP	J24185102		1-	A	B4
R 1365	CHIP RES.	0	1/10W	5%	RMC1/10T 000J	J24205000		1-	B	e4
R 1366	CHIP RES.	0	1/10W	5%	RMC1/10T 000J	J24205000		1-	B	e4
R 1367	CHIP RES.	150	1/16W	5%	RMC1/16 151JATP	J24185151		1-	B	b2
R 1368	CHIP RES.	1k	1/16W	5%	RMC1/16 102JATP	J24185102		1-	B	f3
R 1371	CHIP RES.	10k	1/16W	5%	RMC1/16 103JATP	J24185103		1-	A	E1
R 1372	CHIP RES.	10k	1/16W	5%	RMC1/16 103JATP	J24185103		1	B	b1
R 1372	CHIP RES.	68k	1/16W	5%	RMC1/16 683JATP	J24185683		2-	B	b1
R 1373	CHIP RES.	10k	1/16W	5%	RMC1/16 103JATP	J24185103		1	B	c1
R 1373	CHIP RES.	68k	1/16W	5%	RMC1/16 683JATP	J24185683		2-	B	c1
R 1374	CHIP RES.	10k	1/16W	5%	RMC1/16 103JATP	J24185103		1-	A	D1
R 1375	CHIP RES.	100	1/16W	5%	RMC1/16 101JATP	J24185101		1-	A	F4
R 1376	CHIP RES.	220	1/16W	5%	RMC1/16 221JATP	J24185221		1-	B	e2
R 1377	CHIP RES.	100	1/10W	5%	RMC1/10T 101J	J24205101		1		
R 1378	CHIP RES.	0	1/16W	5%	RMC1/16 000JATP	J24185000		1-	A	F3
R 1379	CHIP RES.	0	1/16W	5%	RMC1/16 000JATP	J24185000		1	B	e1
R 1379	CHIP RES.	100k	1/16W	5%	RMC1/16 104JATP	J24185104		2-	B	e1
R 1380	CHIP RES.	0	1/16W	5%	RMC1/16 000JATP	J24185000		1-	B	d1
R 1381	CHIP RES.	0	1/10W	5%	RMC1/10T 000J	J24205000		1-	A	C1
R 1382	CHIP RES.	0	1/10W	5%	RMC1/10T 000J	J24205000		1-	A	C1
R 1383	CHIP RES.	0	1/16W	5%	RMC1/16 000JATP	J24185000		1	A	D1
R 1383	CHIP RES.	1k	1/16W	5%	RMC1/16 102JATP	J24185102		2-	A	D1
R 1384	CHIP RES.	0	1/16W	5%	RMC1/16 000JATP	J24185000		1	A	C4
R 1384	CHIP RES.	6.8k	1/16W	5%	RMC1/16 682JATP	J24185682		2-	A	C4
R 1385	CHIP RES.	0	1/16W	5%	RMC1/16 000JATP	J24185000		1-	B	f2
R 1386	CHIP RES.	0	1/16W	5%	RMC1/16 000JATP	J24185000		1		
R 1387	CHIP RES.	0	1/16W	5%	RMC1/16 000JATP	J24185000		1-	B	g3
R 1388	CHIP RES.	0	1/16W	5%	RMC1/16 000JATP	J24185000		1-	B	g3
R 1389	CHIP RES.	0	1/10W	5%	RMC1/10T 000J	J24205000		1-	A	B2
R 1390	CHIP RES.	0	1/16W	5%	RMC1/16 000JATP	J24185000		1		
R 1391	CHIP RES.	0	1/16W	5%	RMC1/16 000JATP	J24185000		1		
R 1392	CHIP RES.	0	1/16W	5%	RMC1/16 000JATP	J24185000		1-	B	d4
R 1393	CHIP RES.	470	1/16W	5%	RMC1/16 471JATP	J24185471		1	B	b4
R 1393	CHIP RES.	2.2k	1/16W	5%	RMC1/16 222JATP	J24185222		2-	B	b4
R 1394	CHIP RES.	3.3k	1/16W	5%	RMC1/16 332JATP	J24185332		1-	B	f3
R 1395	CHIP RES.	3.3k	1/16W	5%	RMC1/16 332JATP	J24185332		1	A	B3

MAIN Unit

REF.	DESCRIPTION	VALUE	V/W	TOL.	MFR'S DESIG	VXSTD P/N	VERS.	LOT.	SIDE	LAY ADR
R 1395	CHIP RES.	2.2k	1/16W	5%	RMC1/16 222JATP	J24185222		2-	A	B3
R 1396	CHIP RES.	3.3k	1/16W	5%	RMC1/16 332JATP	J24185332		1	B	g3
R 1396	CHIP RES.	2.2k	1/16W	5%	RMC1/16 222JATP	J24185222		2-	B	g3
R 1397	CHIP RES.	3.3k	1/16W	5%	RMC1/16 332JATP	J24185332		1-	A	C3
R 1398	CHIP RES.	3.3k	1/16W	5%	RMC1/16 332JATP	J24185332		1	B	f3
R 1398	CHIP RES.	2.2k	1/16W	5%	RMC1/16 222JATP	J24185222		2-	B	f3
R 1399	CHIP RES.	10k	1/16W	5%	RMC1/16 103JATP	J24185103		1-	A	C3
R 1400	CHIP RES.	1k	1/16W	5%	RMC1/16 102JATP	J24185102		1-	B	b2
R 1402	CHIP RES.	10k	1/16W	5%	RMC1/16 103JATP	J24185103		2-	B	a3
R 1403	CHIP RES.	47k	1/16W	5%	RMC1/16 473JATP	J24185473		2-	B	b4
R 1404	CHIP RES.	56	1/16W	5%	RMC1/16 560JATP	J24185560		2-	B	b4
R 1405	CHIP RES.	22	1/16W	5%	RMC1/16 220JATP	J24185220		2-	B	a4
R 1406	CHIP RES.	0	1/10W	5%	RMC1/10T 000J	J24205000		2-	A	C2
R 1407	CHIP RES.	100k	1/16W	5%	RMC1/16 104JATP	J24185104		2-	B	f3
R 1408	CHIP RES.	2.2k	1/16W	5%	RMC1/16 222JATP	J24185222		2-	B	f3
R 1409	CHIP RES.	680	1/16W	5%	RMC1/16 681JATP	J24185681		2-	A	B3
R 1410	CHIP RES.	10k	1/16W	5%	RMC1/16 103JATP	J24185103		2-	A	D1
R 1411	CHIP RES.	10k	1/16W	5%	RMC1/16 103JATP	J24185103		2-	A	C1
R 1412	CHIP RES.	10k	1/16W	5%	RMC1/16 103JATP	J24185103		2-	A	D1
R 1413	CHIP RES.	10k	1/16W	5%	RMC1/16 103JATP	J24185103		2-	A	B4
R 1414	CHIP RES.	0	1/16W	5%	RMC1/16 000JATP	J24185000		2-	B	a1
R 1415	CHIP RES.	22k	1/16W	5%	RMC1/16 223JATP	J24185223		2-	B	e3
R 1416	CHIP RES.	68	1/16W	5%	RMC1/16 680JATP	J24185680		2-	A	C3
R 1417	CHIP RES.	0	1/16W	5%	RMC1/16 000JATP	J24185000		2-	A	A2
R 1418	CHIP RES.	100k	1/16W	5%	RMC1/16 104JATP	J24185104		2-	A	E1
R 1419	CARBON FILM RES.	82	1/6W	5%	RD16TPJ820 82	J07225820		2-	B	b1
R 1419	CHIP RES.	82	1/16W	5%	RMC1/16 820JATP	J24185820		5-	B	b1
R 1420	CHIP RES.	100	1/16W	5%	RMC1/16 101JATP	J24185101		2-	B	c2
R 1421	CHIP RES.	10k	1/16W	5%	RMC1/16 103JATP	J24185103		2-	B	b1
R 1422	CHIP RES.	10k	1/16W	5%	RMC1/16 103JATP	J24185103		2-	B	g4
R 1423	CHIP RES.	6.8k	1/16W	5%	RMC1/16 682JATP	J24185682		2-	B	g4
R 1424	CHIP RES.	100k	1/16W	5%	RMC1/16 104JATP	J24185104		2-	B	f5
R 1425	CHIP RES.	3.3k	1/16W	5%	RMC1/16 332JATP	J24185332		2-	B	g3
R 1426	CHIP RES.	68k	1/16W	5%	RMC1/16 683JATP	J24185683		2-	B	g2
R 1427	CHIP RES.	47	1/16W	5%	RMC1/16 470JATP	J24185470		2-	B	c4
R 1428	CHIP RES.	470	1/16W	5%	RMC1/16 471JATP	J24185471		2-	B	b1
R 1429	CHIP RES.	47	1/16W	5%	RMC1/16 470JATP	J24185470		2-	B	b3
R 1430	CHIP RES.	10k	1/16W	5%	RMC1/16 103JATP	J24185103		2-	B	g2
R 1431	CHIP RES.	0	1/16W	5%	RMC1/16 000JATP	J24185000		2-	B	e1
R 1433	CHIP RES.	4.7k	1/16W	5%	RMC1/16 472JATP	J24185472		2-	A	F4
R 1434	CHIP RES.	560	1/16W	5%	RMC1/16 561JATP	J24185561		2-	A	F4
R 1436	CHIP RES.	0	1/16W	5%	RMC1/16 000JATP	J24185000		2-	A	E5
R 1437	CHIP RES.	220	1/16W	5%	RMC1/16 221JATP	J24185221		2-	B	d3
R 1438	CHIP RES.	22	1/16W	5%	RMC1/16 220JATP	J24185220		2-	A	F2
R 1439	CHIP RES.	100	1/16W	5%	RMC1/16 101JATP	J24185101		2-	B	a4
R 1441	CHIP RES.	150	1/16W	5%	RMC1/16 151JATP	J24185151		2-	B	c4
R 1442	CHIP RES.	100	1/16W	5%	RMC1/16 101JATP	J24185101		3-	B	d2
R 1443	CHIP RES.	120k	1/16W	5%	RMC1/16 124JATP	J24185124		2-	B	g3
R 1444	CHIP RES.	220	1/16W	5%	RMC1/16 221JATP	J24185221		2-	B	a2
R 1445	CHIP RES.	10k	1/10W	5%	RMC1/10T 103J	J24205103		2-	A	A2
R 1446	CHIP RES.	0	1/16W	5%	RMC1/16 000JATP	J24185000		2-	B	b2
R 1447	CHIP RES.	3.3k	1/16W	5%	RMC1/16 332JATP	J24185332		2-	B	h2
R 1448	CHIP RES.	3.3k	1/16W	5%	RMC1/16 332JATP	J24185332		2-	A	A2
R 1449	CHIP RES.	3.3k	1/16W	5%	RMC1/16 332JATP	J24185332		2-	B	h3
R 1450	CHIP RES.	3.3k	1/16W	5%	RMC1/16 332JATP	J24185332		2-	B	h3
R 1451	CHIP RES.	3.3k	1/16W	5%	RMC1/16 332JATP	J24185332		2-	B	g2
R 1452	CHIP RES.	15k	1/16W	5%	RMC1/16 153JATP	J24185153		2-	A	D1
R 1453	CHIP RES.	4.7k	1/16W	5%	RMC1/16 472JATP	J24185472		2-	A	D1
R 1454	CHIP RES.	3.3k	1/16W	5%	RMC1/16 332JATP	J24185332		2-	A	C1
R 1455	CHIP RES.	3.3k	1/16W	5%	RMC1/16 332JATP	J24185332		2-	B	g2
R 1456	CHIP RES.	0	1/16W	5%	RMC1/16 000JATP	J24185000		2-	A	B2
R 1457	CHIP RES.	33	1/16W	5%	RMC1/16 330JATP	J24185330		2-	B	c3
R 1458	CHIP RES.	4.7k	1/16W	5%	RMC1/16 472JATP	J24185472		2-	B	d2
R 1459	CHIP RES.	150	1/16W	5%	RMC1/16 151JATP	J24185151		2-	B	d3
R 1460	CHIP RES.	1k	1/16W	5%	RMC1/16 102JATP	J24185102		2-	A	E2
R 1461	CHIP RES.	0	1/10W	5%	RMC1/10T 000J	J24205000		2-	B	e3
R 1462	CHIP RES.	0	1/16W	5%	RMC1/16 000JATP	J24185000		2-	B	e3
R 1463	CHIP RES.	22	1/16W	5%	RMC1/16 220JATP	J24185220		2-	A	G2

REF.	DESCRIPTION	VALUE	V/W	TOL.	MFR'S DESIG	VXSTD P/N	VERS.	LOT.	SIDE	LAY ADR
R 1464	CHIP RES.	1M	1/16W	5%	RMC1/16 105JATP	J24185105		2-	B	e1
R 1465	CHIP RES.	1M	1/16W	5%	RMC1/16 105JATP	J24185105		2-	B	g3
R 1466	CHIP RES.	10k	1/16W	5%	RMC1/16 103JATP	J24185103		2-	B	g2
R 1467	CHIP RES.	4.7k	1/16W	5%	RMC1/16 472JATP	J24185472		2-	B	d3
R 1468	CHIP RES.	100	1/16W	5%	RMC1/16 101JATP	J24185101		2	B	d2
R 1469	CHIP RES.	10k	1/16W	5%	RMC1/16 103JATP	J24185103		2-	B	g1
R 1470	CHIP RES.	1k	1/16W	5%	RMC1/16 102JATP	J24185102		2-	B	g1
R 1471	CHIP RES.	1k	1/16W	5%	RMC1/16 102JATP	J24185102		2-	B	g2
R 1473	CHIP RES.	0	1/16W	5%	RMC1/16 000JATP	J24185000		2-	B	d1
R 1474	CHIP RES.	0	1/10W	5%	RMC1/10T 000J	J24205000		2-	B	c2
R 1475	CHIP RES.	0	1/16W	5%	RMC1/16 000JATP	J24185000		2-	B	c2
R 1476	CARBON FILM RES.	100	1/6W	5%	RD16PJ101 100	J01225101		2-	A	E1
R 1476	CHIP RES.	100	1/16W	5%	RMC1/16 101JATP	J24185101		5-	A	E1
R 1477	CARBON FILM RES.	100	1/6W	5%	RD16PJ101 100	J01225101		2-	A	E1
R 1477	CHIP RES.	100	1/16W	5%	RMC1/16 101JATP	J24185101		5-	A	E1
R 1478	CHIP RES.	15	1/16W	5%	RMC1/16 150JATP	J24185150		2-	B	b1
R 1479	CHIP RES.	15	1/16W	5%	RMC1/16 150JATP	J24185150		2-	B	b1
R 1480	CHIP RES.	1k	1/16W	5%	RMC1/16 102JATP	J24185102		2-	B	b5
R 1481	CHIP RES.	22	1/10W	5%	RMC1/10T 220J	J24205220		4-		
R 1482	CHIP RES.	120k	1/16W	5%	RMC1/16 124JATP	J24185124		16-		
R 1483	CARBON FILM RES.	3.3k	1/6W	5%	RD16PJ332 3.3K	J01225332		41-		
RL1001	RELAY		DC9V		AG4017 DC9V	M1190114		1-	A	G1
T 1001	COIL 07WIDE				4-1 2D3 TR6X3	L0020788A		1-	A	E2
T 1002	COIL 04WIDE				4BLH-4	L0022449		1-	A	E2
T 1003	COIL 05RF				M5-N R12-S981Y	L0022555		1-	A	H1
T 1004	COIL 04WIDE				4BLH-4	L0022449		1-	A	E3
T 1005	COIL 07WIDE				4-1 2D3 TR6X3	L0020788A		1-	A	E3
T 1006	COIL 05RF				M5-N R12-S983Y	L0022557		1-	A	H2
T 1008	COIL 05RF				R12-S980Y	L0022503		1-	A	E3
T 1009	COIL 05RF				M5-N R12-S982Y	L0022556		1-	A	H2
T 1010	COIL 05RF				R12-S977Y	L0022500		1		
T 1011	COIL 05RF				R12-S978Y	L0022501		1-	A	E3
T 1012	COIL 05RF				M5-N R12-S981Y	L0022555		1-	A	H3
T 1014	COIL 05RF				R12-S975Y	L0022498		1	A	E3
T 1014	COIL 05RF				R12-S974Y	L0022497		2-	A	E3
T 1015	COIL 04WIDE				4BLH-4	L0022449		1-	A	G3
T 1016	COIL 07WIDE				2001F	L0021973		1-	A	G3
T 1017	COIL 07WIDE				4-1 2001F FR6	L0021351		1	A	F3
T 1017	COIL 07WIDE				2001F	L0021973		2-	A	F3
T 1018	COIL 05RF				M5-N R12-S981Y	L0022555		1-	A	E2
T 1019	COIL 04WIDE				4BLH-4	L0022449		1-	A	H3
T 1020	COIL 05RF				R12-S970B	L0022493		1-	A	E4
T 1021	COIL 05RF				M5-N R12-S981Y	L0022555		1-	A	E2
T 1022	COIL 05RF				R12-S971B	L0022494		1-	A	E4
T 1023	COIL 05RF				R12-S980Y	L0022503		1	A	G3
T 1023	COIL 05RF				R12-S977Y	L0022500		2-	A	G3
T 1024	COIL 05RF				M5-N R12-S981Y	L0022555		1		
T 1025	COIL 05RF				R12-S976Y	L0022499		1	A	H3
T 1025	COIL 05RF				R12-S976Y	L0022499		2-	A	H3
T 1026	COIL 05RF				M5-N R12-S981Y	L0022555		1-	A	E3
T 1027	COIL 05RF				R12-S975Y	L0022498		1	A	H4
T 1027	COIL 05RF				R12-S976Y	L0022499		2-	A	H4
T 1028	COIL 05RF				R12-S979Y	L0022502		1	A	G5
T 1028	COIL 05RF				R12-S976Y	L0022499		2-	A	G5
T 1029	COIL 05RF				R12-S971B	L0022494		1-	A	F4
T 1030	COIL 05RF				R12-S971B	L0022494		1-	A	G5
T 1031	COIL 05RF				R12-S971B	L0022494		1-	A	F4
T 1032	COIL 05RF				R12-S971B	L0022494		1-	A	F5
T 1033	COIL 05RF				R12-S971B	L0022494		1-	A	C3
T 1034	COIL 05RF				R12-S971B	L0022494		1-	A	F5
T 1035	COIL 05RF				R12-S971B	L0022494		1-	A	C2
T 1036	COIL 05RF				R12-S971B	L0022494		1-	A	F5
T 1037	COIL 05RF				R12-S972B	L0022495		1-	A	C2
T 1039	COIL 05RF				R12-S975Y	L0022498		1	A	H4
T 1039	COIL 05RF				R12-S978Y	L0022501		2-	A	H4
T 1040	COIL 05RF				K5-N R12-S985Y	L0022559		1-	A	D2
TC1001	TRIMMER CAP.	6pF			ECR-KN006A61X 6P	K91000225		2-	A	D2
TH1001	THERMISTOR				157-501-53009TP	G9090058		1-	B	c4

MAIN Unit

REF.	DESCRIPTION	VALUE	V/W	TOL.	MFR'S DESIG	VXSTD P/N	VERS.	LOT.	SIDE	LAY ADR
TH1002	THERMISTOR				157-501-53009TP	G9090058		1-	B	a5
TH1003	THERMISTOR				157-501-53009TP	G9090058		1		
TH1004	THERMISTOR				157-501-53009TP	G9090058		2-	B	e2
TH1006	THERMISTOR				157-501-53009TP	G9090058		2-	B	a2
TH1007	THERMISTOR				157-152-53009-TP	G9090123		2-	B	e3
TP1002	TERMINAL				TP-N IPS-1091	Q5000082		2-	A	A3
TP1003	TERMINAL				TP-N IPS-1091	Q5000082		2-	A	A2
TP1004	TERMINAL				TP-N IPS-1091	Q5000082		2-	A	C3
TP1005	TERMINAL				TP-N IPS-1091	Q5000082		2-	A	B3
TP1006	TERMINAL				TP-N IPS-1091	Q5000082		2-	A	C3
TP1007	TERMINAL				TP-N IPS-1091	Q5000082		2-	A	A2
TP1008	TERMINAL				TP-N IPS-1091	Q5000082		2-	A	A2
TP1009	TERMINAL				TP-N IPS-1091	Q5000082		2-	A	C3
VR1001	POT.	470			RH03A3AS2X 470	J51807471		1-	A	F3
VR1002	POT.	10k			RH03A3A14X 10K	J51807103		1-	A	D2
VR1003	POT.	10k			RH03A3A14X 10K	J51807103		1-	A	D2
VR1004	POT.	10k			RH03A3A14X 10K	J51807103		1-	A	B2
X 1001	XTAL UM-1	11.705MHz			11.705MHZ	H0103186		1-	A	D2
X 1002	XTAL UM-1	12.16MHz			12.160MHZ	H0103187		1-	A	F4
X 1003	XTAL HC-49/U	8.23MHz			8.23MHZ	H0103213		2-	A	A4
XF1002	XTAL FILTER				XF-118S	H1102316		1-	A	D3
XF1003	XTAL FILTER				XF-117CN	H1102305	W/XF-117CN	1-48	A	E5
XF1003	XTAL FILTER				XF-117CN	H1102305	XF-117CN	49-	A	E5
XF1004	XTAL FILTER				XF-117C	H1102306	W/XF-117C	1-	A	E4
XF1005	XTAL FILTER				74M15BUF	H1102315		1	A	H4
XF1005	XTAL FILTER				68R15BU	H1102296		2-	A	H4
XF1006	XTAL FILTER				74M15BUF	H1102315		1	A	H4
XF1006	XTAL FILTER				68R15BU	H1102296		2-	A	H4
XF1007	XTAL FILTER				XF-117A	H1102313	W/XF-117A	1-		
	XTAL SPACER					R7076390		2-		
	SHIELD PLATE					RA0147000		2-		
	LEAF SPRING					R0140031		2-		

6M-

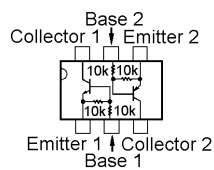
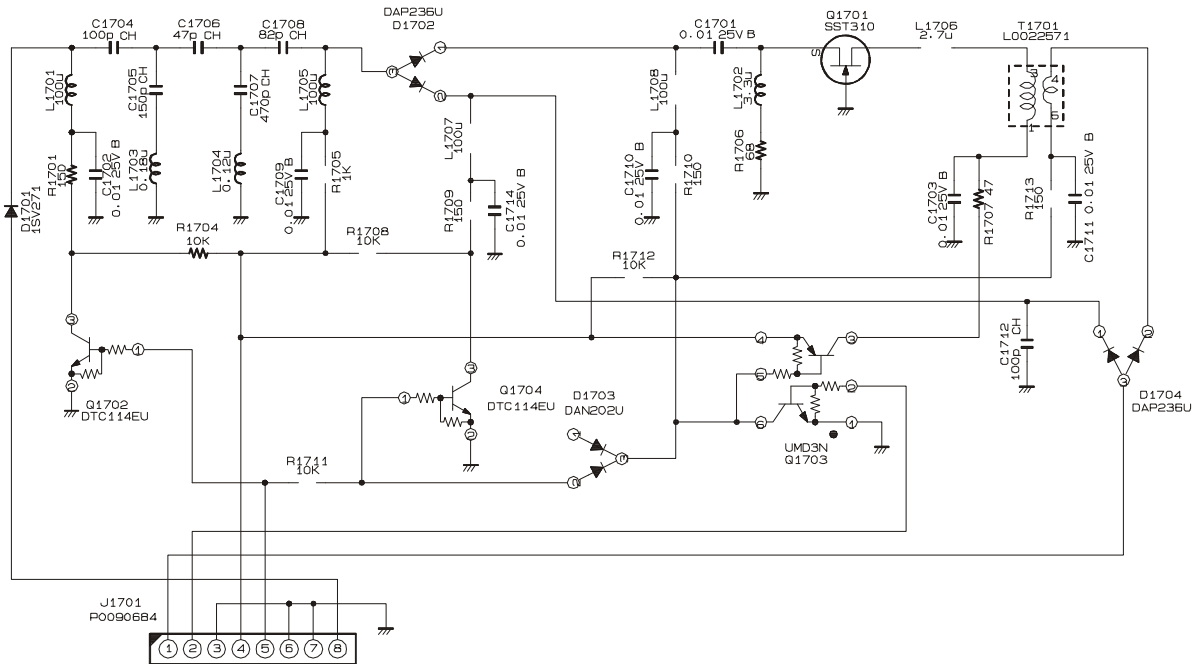

SST310 (Z0)
(Q1701, 1705)

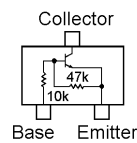

UMD3N (D3)
(Q1703)

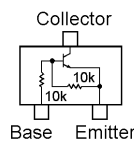

2SC4047 (ZY) (Lot.1)
(Q1702)

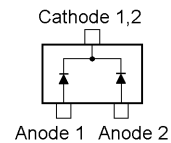

DAN235U (M) (Lot.1)
(D1702)
DAN202U (N) (Lot.2-)
(D1703)

DTC114EU (24) (Lot.2-)
(Q1702, 1704)

DAP236U (M) (Lot.2-)
(D1702, 1704)

6m-Filter Unit

Parts List

REF.	DESCRIPTION	VALUE	V/W	TOL.	MFR'S DESIG	VXSTD P/N	VERS.	LOT.	SIDE	LAY ADR
*** 6M-FIL-UNIT ***										
PCB with Components						CB0421001				
PB1701	Printed Circuit Board	FR001840C								
C 1701	CHIP CAP.	0.01uF	25V	B	GRM39B103K25PT	K22144803		1-	B	
C 1702	CHIP CAP.	0.01uF	25V	B	GRM39B103K25PT	K22144803		1-	B	
C 1703	CHIP CAP.	0.01uF	25V	B	GRM39B103K25PT	K22144803		1-	A	
C 1704	CHIP CAP.	100pF	50V	CH	GRM39CH101J50PT	K22174235		1-	B	
C 1705	CHIP CAP.	150pF	50V	CH	GRM39CH151J50PT	K22174239		1-	B	
C 1706	CHIP CAP.	47pF	50V	CH	GRM39CH470J50PT	K22174227		1-	B	
C 1707	CHIP CAP.	470pF	50V	B	GRM39B471M50PT	K22174805		1	B	
C 1707	CHIP CAP.	470pF	50V	CH	GRM39CH471J50PT	K22174249		2-	B	
C 1708	CHIP CAP.	82pF	50V	CH	GRM39CH820J50PT	K22174233		1-	B	
C 1709	CHIP CAP.	0.01uF	25V	B	GRM39B103K25PT	K22144803		1-	A	
C 1710	CHIP CAP.	1pF	50V	CK	GRM39CK010C50PT	K22174202		1	A	
C 1710	CHIP CAP.	0.01uF	25V	B	GRM39B103K25PT	K22144803		2-	A	
C 1711	CHIP CAP.	0.01uF	25V	B	GRM39B103K25PT	K22144803		2-	A	
C 1712	CHIP CAP.	100pF	50V	CH	GRM39CH101J50PT	K22174235		2-3	B	
C 1712	CHIP CAP.	100pF	50V	CH	GRM39CH101J50PT	K22174235		5-	B	
C 1714	CHIP CAP.	0.01uF	25V	B	GRM39B103K25PT	K22144803		2-	A	
D 1701	DIODE				1SV271 TPH3	G2070476		1-	B	
D 1702	DIODE				DAN235U TL	G2070176		1	B	
D 1702	DIODE				DAP236U T106	G2070592		2-	B	
D 1703	DIODE				DAN202U T106	G2070162		2-	B	
D 1704	DIODE				DAP236U T106	G2070592		2-	B	
J 1701	CONNECTOR				9230B-1-08Z009-T	P0090684		1-	A	
L 1701	M.RFC	100uH			FLC32T-101J	L1690227		1-	B	
L 1702	CHIP COIL	3.3uH			C2520C-3R3K	L1690733		1-	B	
L 1703	CHIP COIL	0.18uH			C2520C-R18J	L1690547		1-	A	
L 1704	CHIP COIL	0.12uH			C2520C-R12J	L1690545		1-	A	
L 1705	M.RFC	100uH			FLC32T-101J	L1690227		1-	A	
L 1706	CHIP COIL	2.7uH			C2520C-2R7K	L1690732		2-	A	
L 1706	CHIP COIL	1.5uH			C2520C-1R5K	L1690729		34-	A	
L 1707	M.RFC	100uH			FLC32T-101J	L1690227		2-	A	
L 1708	M.RFC	100uH			FLC32T-101J	L1690227		2-	A	
Q 1701	FET				SST310-T1	G4070009		1-	A	
Q 1702	TRANSISTOR				2SC4047-TA	G3340477		1	B	
Q 1702	TRANSISTOR				DTC114EU T106	G3070084		2-	B	
Q 1703	TRANSISTOR				UMD3N TR	G3070211		2-	B	
Q 1704	TRANSISTOR				DTC114EU T106	G3070084		2-	B	
Q 1705	FET				SST310-T1	G4070009		34-	B	
R 1701	CHIP RES.	150	1/16W	5%	RMC1/16 151JATP	J24185151		1-	B	
R 1702	CHIP RES.	68	1/16W	5%	RMC1/16 680JATP	J24185680		1		
R 1703	CHIP RES.	47	1/16W	5%	RMC1/16 470JATP	J24185470		1		
R 1704	CHIP RES.	10k	1/16W	5%	RMC1/16 103JATP	J24185103		1-	B	
R 1705	CHIP RES.	150	1/16W	5%	RMC1/16 151JATP	J24185151		1	A	
R 1705	CHIP RES.	1k	1/16W	5%	RMC1/16 102JATP	J24185102		2-	A	
R 1706	CHIP RES.	68	1/10W	5%	RMC1/10T 680J	J24205680		2-	B	
R 1707	CHIP RES.	47	1/10W	5%	RMC1/10T 470J	J24205470		2-	B	
R 1708	CHIP RES.	10k	1/16W	5%	RMC1/16 103JATP	J24185103		2-	B	
R 1709	CHIP RES.	150	1/16W	5%	RMC1/16 151JATP	J24185151		2-	A	
R 1710	CHIP RES.	150	1/16W	5%	RMC1/16 151JATP	J24185151		2-	A	
R 1711	CHIP RES.	10k	1/16W	5%	RMC1/16 103JATP	J24185103		2-	B	
R 1712	CHIP RES.	10k	1/16W	5%	RMC1/16 103JATP	J24185103		2-	A	
R 1713	CHIP RES.	150	1/16W	5%	RMC1/16 151JATP	J24185151		2-	B	
R 1714	CHIP RES.	0	1/10W	5%	RMC1/10T 000J	J24205000		2-	B	
T 1701	COIL 04WIDE				4BLH #222910	L0022571		1-	A	

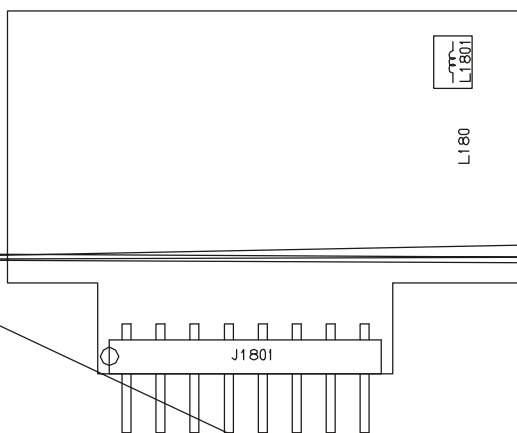

DAN235U (M)
(D1801, 1802,
1803, 1804)

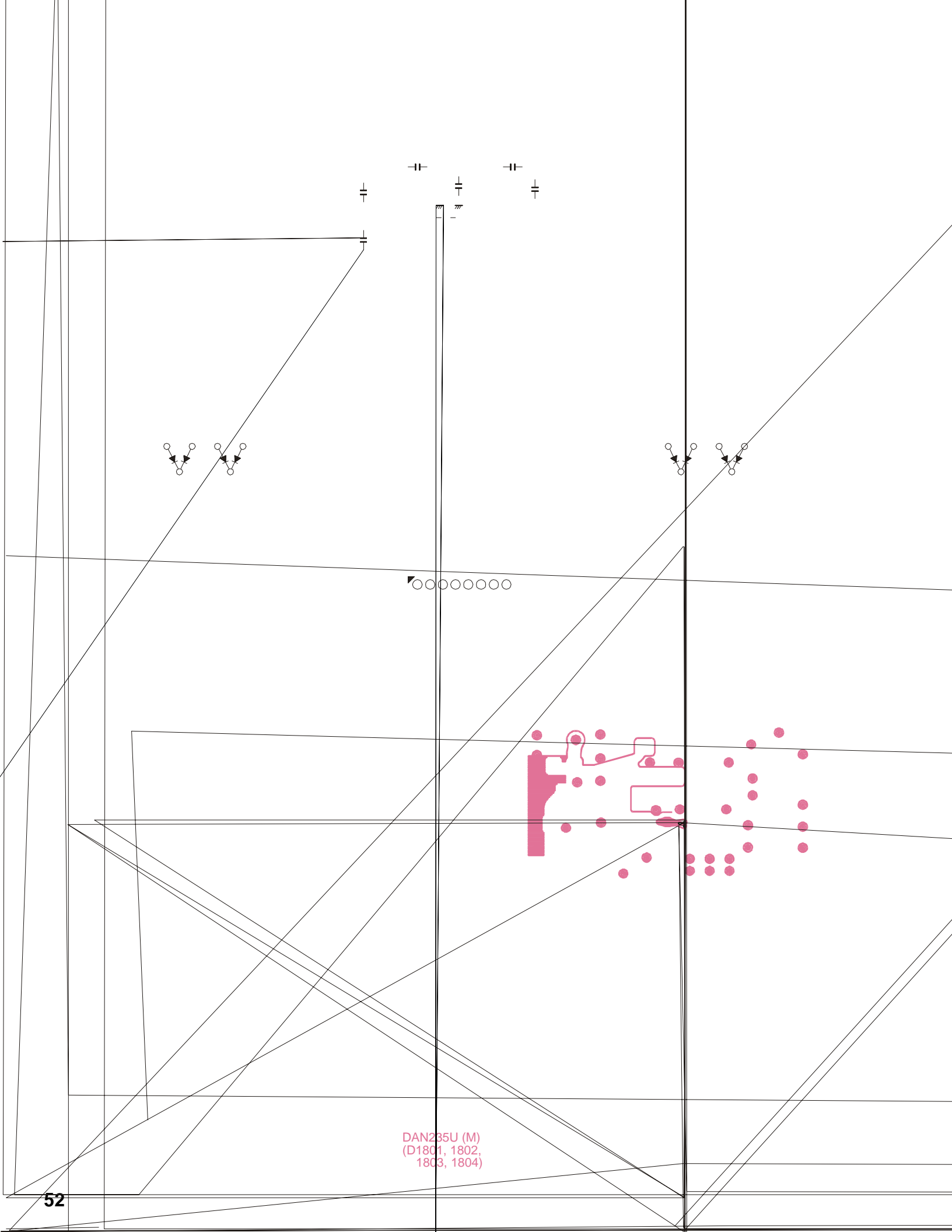

DAN235U (M)
(D1801, 1802,
1803, 1804)

Parts List

REF.	DESCRIPTION	VALUE	V/W	TOL.	MFR'S DESIG	VXSTD P/N	VERS.	LOT.	SIDE	LAY ADR
*** BPF UNIT ***										
PCB with Components						CB0422001				
Printed Circuit Board						FR001850A		1-		
Printed Circuit Board						FR001850B		9-		
C 1801	CHIP CAP.	27pF	50V	CH	GRM39CH270J50PT	K22174221		1-	A	
C 1802	CHIP CAP.	0.01uF	25V	B	GRM39B103K25PT	K22144803		1-	B	
C 1803	CHIP CAP.	10pF	50V	CH	GRM39CH100D50PT	K22174211		1-	A	
C 1804	CHIP CAP.	0.01uF	25V	B	GRM39B103K25PT	K22144803		1-	B	
C 1805	CHIP CAP.	4pF	50V	CH	GRM39CH040C50PT	K22174205		1-	A	
C 1806	CHIP CAP.	0.001uF	50V	B	GRM39B102K50PT	K22174821		1-	B	
C 1807	CHIP CAP.	0.001uF	50V	B	GRM39B102K50PT	K22174821		1-	B	
C 1808	CHIP CAP.	33pF	50V	CH	GRM39CH330J50PT	K22174223		1-	A	
C 1809	CHIP CAP.	18pF	50V	CH	GRM39CH180J50PT	K22174217		1-	A	
C 1810	CHIP CAP.	4pF	50V	CH	GRM39CH040C50PT	K22174205		1-	A	
C 1811	CHIP CAP.	56pF	50V	CH	GRM39CH560J50PT	K22174229		1-	A	
C 1812	CHIP CAP.	12pF	50V	CH	GRM39CH120J50PT	K22174213		1-	A	
C 1813	CHIP CAP.	6pF	50V	CH	GRM39CH060D50PT	K22174207		1-	A	
C 1814	CHIP CAP.	33pF	50V	CH	GRM39CH330J50PT	K22174223		1-	A	
C 1815	CHIP CAP.	18pF	50V	CH	GRM39CH180J50PT	K22174217		1-	A	
C 1816	CHIP CAP.	4pF	50V	CH	GRM39CH040C50PT	K22174205		1-	A	
C 1817	CHIP CAP.	27pF	50V	CH	GRM39CH270J50PT	K22174221		1-	A	
C 1818	CHIP CAP.	10pF	50V	CH	GRM39CH100D50PT	K22174211		1-	A	
C 1819	CHIP CAP.	0.001uF	50V	B	GRM39B102K50PT	K22174821		1-	B	
C 1820	CHIP CAP.	4pF	50V	CH	GRM39CH040C50PT	K22174205		1-	A	
C 1821	CHIP CAP.	0.01uF	25V	B	GRM39B103K25PT	K22144803		1-	B	
C 1822	CHIP CAP.	0.01uF	25V	B	GRM39B103K25PT	K22144803		1-	B	
C 1823	CHIP CAP.	0.001uF	50V	B	GRM39B102K50PT	K22174821		1-	B	
D 1801	DIODE				DAN235U TL	G2070176		1-	B	
D 1802	DIODE				DAN235U TL	G2070176		1-	B	
D 1803	DIODE				DAN235U TL	G2070176		1-	B	
D 1804	DIODE				DAN235U TL	G2070176		1-	B	
J 1801	CONNECTOR				9230B-1-08Z009-T	P0090684		1-	A	
L 1801	M.RFC	0.1uH			C2012C-R10K	L1690676		1-	A	
L 1802	M.RFC	0.039uH			C2012C-39NK	L1690671		1-	A	
L 1803	M.RFC	0.012uH			C2012C-12NK	L1690665		1-	A	
L 1804	M.RFC	0.1uH			C2012C-R10K	L1690676		1-	A	
L 1805	M.RFC	0.033uH			C2012C-33NK	L1690670		1-	A	
L 1806	M.RFC	0.012uH			C2012C-12NK	L1690665		1-	A	
L 1807	M.RFC	0.056uH			C2012C-56NK	L1690673		1-	A	
L 1808	M.RFC	0.022uH			C2012C-22NK	L1690668		1-	A	
L 1809	CHIP COIL	0.0147uH			LQN1A15NJ04	L1690251		1-	A	
L 1810	M.RFC	0.1uH			C2012C-R10K	L1690676		1-	A	
L 1811	M.RFC	0.033uH			C2012C-33NK	L1690670		1-	A	
L 1812	M.RFC	0.012uH			C2012C-12NK	L1690665		1-	A	
L 1813	M.RFC	0.1uH			C2012C-R10K	L1690676		1-	A	
L 1814	M.RFC	0.039uH			C2012C-39NK	L1690671		1-	A	
L 1815	M.RFC	0.012uH			C2012C-12NK	L1690665		1-	A	
R 1801	CHIP RES.	150	1/16W	5%	RMC1/16 151JATP	J24185151		1-	B	
R 1802	CHIP RES.	150	1/16W	5%	RMC1/16 151JATP	J24185151		1-	B	
R 1803	CHIP RES.	150	1/16W	5%	RMC1/16 151JATP	J24185151		1-	B	
R 1804	CHIP RES.	100	1/16W	5%	RMC1/16 101JATP	J24185101		1-	B	
R 1805	CHIP RES.	100	1/16W	5%	RMC1/16 101JATP	J24185101		1-	B	
R 1806	CHIP RES.	100	1/16W	5%	RMC1/16 101JATP	J24185101		1-	B	

BPF Unit

Note:

Circuit Diagram

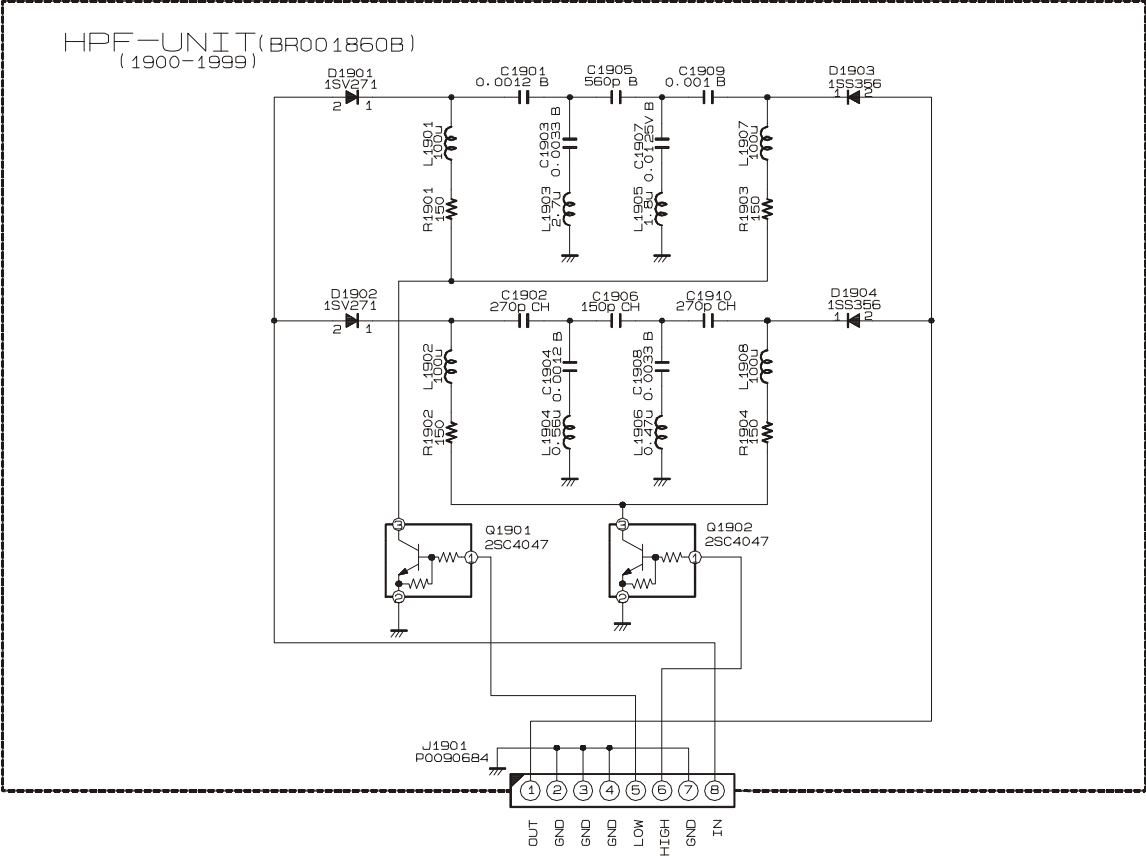

Parts Layout

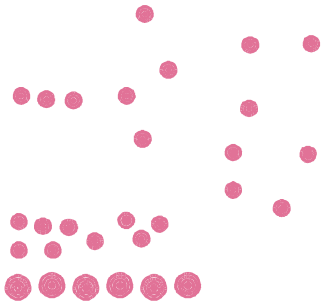

Side A

Side B

2SC4047 (ZY)
(Q1901, 1902)

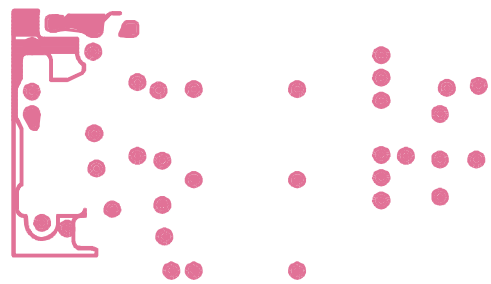

Parts List

REF.	DESCRIPTION	VALUE	V/W	TOL.	MFR'S DESIG	VXSTD P/N	VERS.	LOT.	SIDE	LAY ADR
*** HPF UNIT ***										
PCB with Components						CB0423001				
Printed Circuit Board						FR001860B		1-		
Printed Circuit Board						FR001860C		6-		
C 1901	CHIP CAP.	0.0012uF	50V	B	GRM39B122M50PT	K22174810		1-	B	
C 1902	CHIP CAP.	270pF	50V	CH	GRM39CH271J50PT	K22174251		1-	B	
C 1903	CHIP CAP.	0.0033uF	50V	B	GRM39B332M50PT	K22174815		1-	A	
C 1904	CHIP CAP.	0.0012uF	50V	B	GRM39B122M50PT	K22174810		1-	A	
C 1905	CHIP CAP.	560pF	50V	B	GRM39B561M50PT	K22174806		1-	B	
C 1906	CHIP CAP.	150pF	50V	CH	GRM39CH151J50PT	K22174239		1-	B	
C 1907	CHIP CAP.	0.01uF	25V	B	GRM39B103K25PT	K22144803		1-	A	
C 1908	CHIP CAP.	0.0033uF	50V	B	GRM39B332M50PT	K22174815		1-	A	
C 1909	CHIP CAP.	0.001uF	50V	B	GRM39B102M50PT	K22174809		1-	B	
C 1910	CHIP CAP.	270pF	50V	CH	GRM39CH271J50PT	K22174251		1-	B	
C 1911	CHIP CAP.	150pF	50V	CH	GRM39CH151J50PT	K22174239		6-	B	
C 1912	CHIP CAP.	120pF	50V	CH	GRM39CH121J50PT	K22174237		6-	A	
C 1913	CHIP CAP.	100pF	50V	CH	GRM39CH101J50PT	K22174235		6-	B	
C 1914	CHIP CAP.	470pF	50V	CH	GRM39CH471J50PT	K22174249		6-	A	
C 1915	CHIP CAP.	100pF	50V	CH	GRM39CH101J50PT	K22174235		6-	B	
D 1901	DIODE				1SV271 TPH3	G2070476		1-	B	
D 1902	DIODE				1SV271 TPH3	G2070476		1-	B	
D 1903	DIODE				1SS356TW11	G2070468		1-	B	
D 1904	DIODE				1SS356TW11	G2070468		1-	B	
D 1905	DIODE				1SV271 TPH3	G2070476		6-	B	
D 1906	DIODE				1SS356TW11	G2070468		6-	B	
D 1907	DIODE				1SS400 TE61	G2070634		6-	B	
D 1907	DIODE				MA2S111-(TX)	G2070614		13-	B	
J 1901	CONNECTOR				9230B-1-08Z009-T	P0090684		1-	B	
JP1901	WIRE ASSY				GRN 100 2/2	T50510000		6-		
L 1901	M.RFC	100uH			FLC32T-101J	L1690227		1-	A	
L 1902	M.RFC	100uH			FLC32T-101J	L1690227		1-	A	
L 1903	CHIP COIL	2.7uH			C2520C-2R7K	L1690732		1-	A	
L 1904	CHIP COIL	0.56uH			C2520C-R56J	L1690553		1-	A	
L 1905	CHIP COIL	1.8uH			C2520C-1R8K	L1690730		1-	A	
L 1906	CHIP COIL	0.47uH			C2520C-R47J	L1690552		1-	A	
L 1907	M.RFC	100uH			FLC32T-101J	L1690227		1-	A	
L 1908	M.RFC	100uH			FLC32T-101J	L1690227		1-	A	
L 1909	M.RFC	100uH			FLC32T-101J	L1690227		6-	A	
L 1910	CHIP COIL	0.68uH			C2520C-R68J	L1690554		6-	A	
L 1911	CHIP COIL	0.39uH			C2520C-R39J	L1690551		6-	A	
L 1912	M.RFC	100uH			FLC32T-101J	L1690227		6-	A	
Q 1901	TRANSISTOR				2SC4047-TA	G3340477		1-	B	
Q 1901	TRANSISTOR				DTC114EU T106	G3070084		6-	B	
Q 1902	TRANSISTOR				2SC4047-TA	G3340477		1-	B	
Q 1902	TRANSISTOR				DTC114EU T106	G3070084		6-	B	
Q 1903	TRANSISTOR				DTC114EU T106	G3070084		6-	B	
R 1901	CHIP RES.	150	1/16W	5%	RMC1/16 151JATP	J24185151		1-	A	
R 1902	CHIP RES.	150	1/16W	5%	RMC1/16 151JATP	J24185151		1-	B	
R 1903	CHIP RES.	150	1/16W	5%	RMC1/16 151JATP	J24185151		1-	B	
R 1904	CHIP RES.	150	1/16W	5%	RMC1/16 151JATP	J24185151		1-	B	
R 1905	CHIP RES.	150	1/16W	5%	RMC1/16 151JATP	J24185151		6-	B	
R 1906	CHIP RES.	150	1/16W	5%	RMC1/16 151JATP	J24185151		6-	B	
R 1908	CHIP RES.	10k	1/16W	5%	RMC1/16 103JATP	J24185103		6-	A	

HPF Unit

Note:

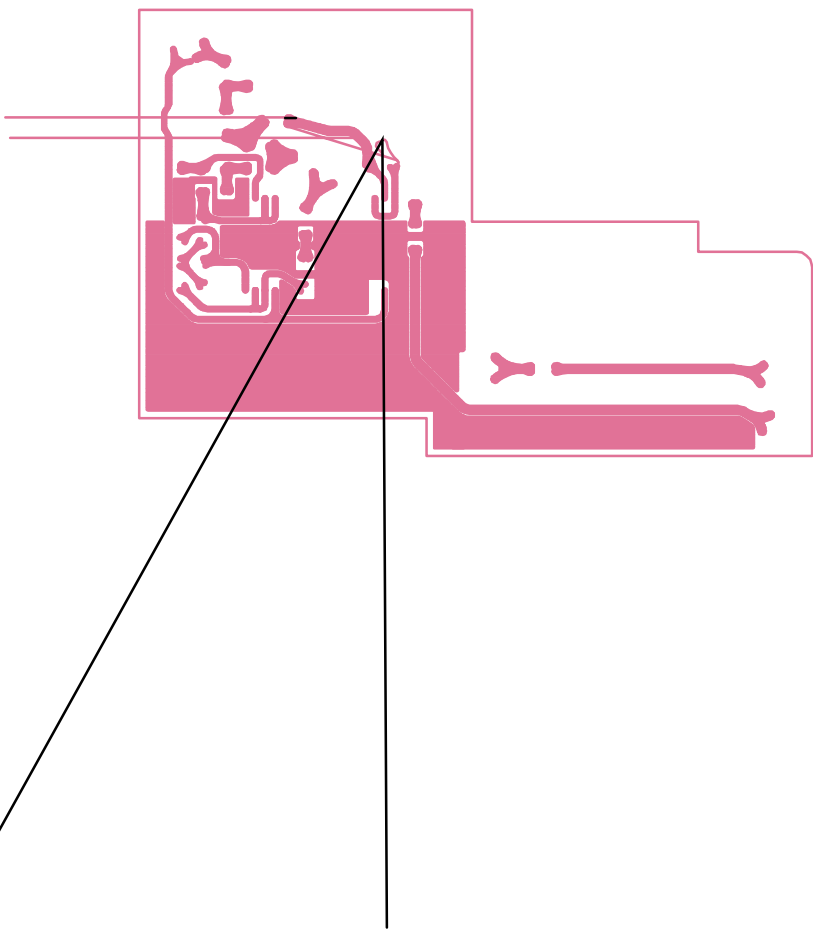

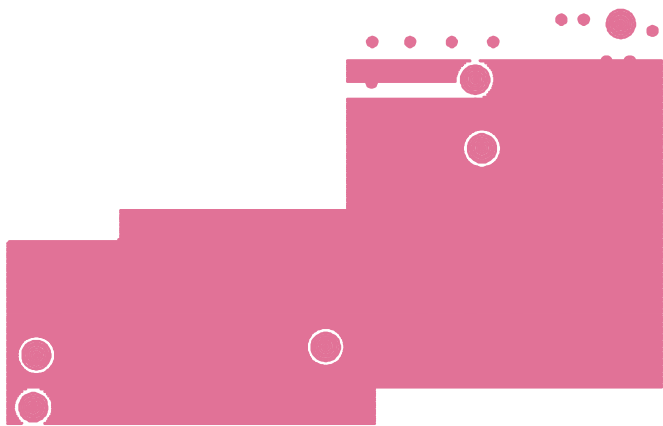

Audio-Filter Unit

Parts List

REF.	DESCRIPTION	VALUE	V/W	TOL.	MFR'S DESIG	VXSTD P/N	VERS.	LOT.	SIDE	LAY ADR
*** AUDIO-FIL UNIT ***										
PCB with Components						CB0674001				
Printed Circuit Board						FR003110A		1-		
Printed Circuit Board						FR003110B		5-		
C 1951	CHIP TA.CAP.	1uF	10V		TESVSP1A105M-8R	K78100032		1-	B	
C 1952	CHIP TA.CAP.	4.7uF	10V		TEMSVA21A475M-8R	K78100045		1	B	
C 1953	CHIP CAP.	0.01uF	25V	B	GRM39B103K25PT	K22144803		1	B	
C 1954	CHIP TA.CAP.	10uF	10V		TEMSVA1A106M-8R	K78100028		1	B	
C 1954	CHIP TA.CAP.	22uF	6.3V		TEMSVA0J226M-8R	K78080047		2-	B	
C 1955	CHIP CAP.	0.1uF	16V	B	GRM39B104K16PT	K22124805		1	B	
C 1955	CHIP TA.CAP.	10uF	6.3V		TESVSP0J106M-8R	K78080055		2-	B	
C 1956	CHIP CAP.	0.0056uF	50V	B	GRM39B562M50PT	K22174818		1-	B	
C 1957	CHIP CAP.	0.0047uF	50V	B	GRM39B472M50PT	K22174817		1-	B	
C 1958	CHIP CAP.	0.0012uF	50V	B	GRM39B122M50PT	K22174810		1	B	
C 1958	CHIP CAP.	0.012uF	50V	B	GRM39B123K50PT	K22174825		2-	B	
C 1959	CHIP CAP.	0.0018uF	50V	B	GRM39B182M50PT	K22174812		1-	B	
C 1960	CHIP TA.CAP.	1uF	10V		TESVSP1A105M-8R	K78100032		1-	B	
C 1961	CHIP CAP.	0.1uF	16V	B	GRM39B104K16PT	K22124805		1-	B	
Q 1951	IC				NJM2904V-TE1	G1091677		1-	B	
Q 1952	IC				NJM2904V-TE1	G1091677		1-	B	
R 1951	CHIP RES.	10k	1/16W	5%	RMC1/16 103JATP	J24185103		1-	B	
R 1952	CHIP RES.	10k	1/16W	5%	RMC1/16 103JATP	J24185103		1	B	
R 1952	CHIP RES.	100k	1/16W	5%	RMC1/16 104JATP	J24185104		2-	B	
R 1953	CHIP RES.	4.7k	1/16W	5%	RMC1/16 472JATP	J24185472		1	B	
R 1953	CHIP RES.	10k	1/16W	5%	RMC1/16 103JATP	J24185103		2-	B	
R 1954	CHIP RES.	5.6k	1/16W	5%	RMC1/16 562JATP	J24185562		1-	B	
R 1955	CHIP RES.	3.3k	1/16W	5%	RMC1/16 332JATP	J24185332		1	B	
R 1955	CHIP RES.	0	1/16W	5%	RMC1/16 000JATP	J24185000		2-	B	
R 1956	CHIP RES.	6.8k	1/16W	5%	RMC1/16 682JATP	J24185682		1-	B	
R 1957	CHIP RES.	6.8k	1/16W	5%	RMC1/16 682JATP	J24185682		1-	B	
R 1958	CHIP RES.	10k	1/16W	5%	RMC1/16 103JATP	J24185103		1	B	
R 1958	CHIP RES.	12k	1/16W	5%	RMC1/16 123JATP	J24185123		2-	B	
R 1959	CHIP RES.	10k	1/16W	5%	RMC1/16 103JATP	J24185103		1-	B	
R 1960	CHIP RES.	10k	1/16W	5%	RMC1/16 103JATP	J24185103		1-	B	
R 1962	CHIP RES.	6.8k	1/16W	5%	RMC1/16 682JATP	J24185682		1-	B	
R 1963	CHIP RES.	6.8k	1/16W	5%	RMC1/16 682JATP	J24185682		1-	B	
R 1964	CHIP RES.	10k	1/16W	5%	RMC1/16 103JATP	J24185103		1-	B	
R 1965	CHIP RES.	3.3k	1/16W	5%	RMC1/16 332JATP	J24185332		2-	B	
TP1951	TERMINAL				TP-N IPS-1091	Q5000082		2-	A	
TP1952	TERMINAL				TP-N IPS-1091	Q5000082		2-	A	
TP1953	TERMINAL				TP-N IPS-1091	Q5000082		2-	A	
TP1954	TERMINAL				TP-N IPS-1091	Q5000082		2-	A	
TP1955	TERMINAL				TP-N IPS-1091	Q5000082		2-	A	
TP1956	TERMINAL				TP-N IPS-1091	Q5000082		2-	A	
TP1957	TERMINAL				TP-N IPS-1091	Q5000082		2-	A	
TP1958	TERMINAL				TP-N IPS-1091	Q5000082		2-	A	
	LEAF SPRING					R0140031		34-		

Audio-Filter Unit

Note:



Local Unit

B

b

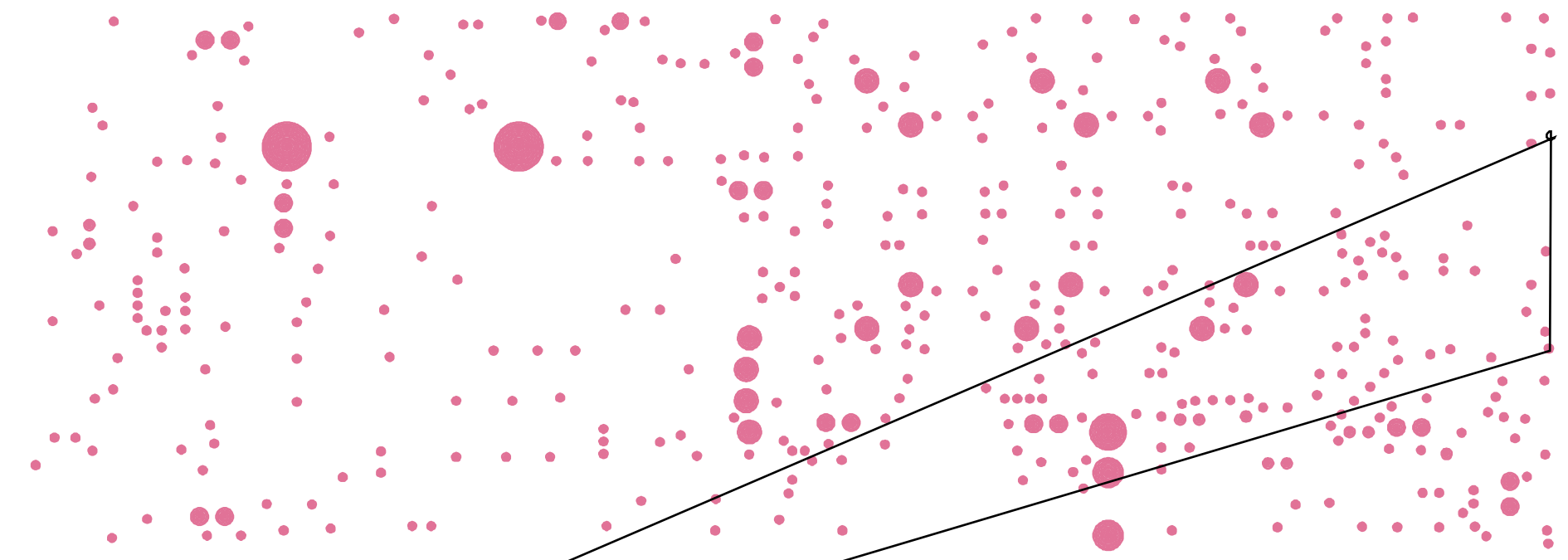

64

*** LOCAL-UNIT ***

PCB with Components						CS1618001	W/O CE LABEL		
PCB with Components						CS1618002	W/ CE LABEL		
Printed Circuit Board						FR001640D			
C 2001	CHIP TA.CAP.	0.47uF	20V		TEMSVA21D474M-8R	K78130023	1	A	C2
C 2001	CHIP TA.CAP.	0.047uF	35V		TESVA1V473M1-8R	K78160023	2-	A	C2
C 2002	CHIP CAP.	0.001uF	50V	B	GRM39B102K50PT	K22174821	1-	B	d1
C 2003	CHIP CAP.	0.001uF	50V	B	GRM39B102K50PT	K22174821	1-	B	f1
C 2004	CHIP CAP.	0.0047uF	50V	B	GRM39B472M50PT	K22174817	1-	A	C2
C 2005	CHIP TA.CAP.	2.2uF	16V		TEMSVA21C225M-8R	K78120030	1-	A	C2
C 2006	CHIP CAP.	0.001uF	50V	B	GRM39B102K50PT	K22174821	1-	A	D2
C 2007	CHIP CAP.	0.001uF	50V	B	GRM39B102K50PT	K22174821	1-	A	D2
C 2008	CHIP CAP.	0.001uF	50V	B	GRM39B102K50PT	K22174821	1-	A	D1
C 2009	CHIP CAP.	0.001uF	50V	B	GRM39B102K50PT	K22174821	1-	A	D1
C 2010	CHIP CAP.	47pF	50V	CH	GRM39CH470J50PT	K22174227	1-	A	C1
C 2011	CHIP CAP.	0.001uF	50V	B	GRM39B102K50PT	K22174821	1-	A	C2
C 2012	CHIP CAP.	0.001uF	50V	B	GRM39B102K50PT	K22174821	1-	B	f2
C 2013	CHIP CAP.	15pF	50V	CH	GRM39CH150J50PT	K22174215	1-	A	D2
C 2014	CHIP CAP.	8pF	50V	UJ	GRM39UJ080D50PT	K22174308	1-	A	C2
C 2015	CHIP CAP.	8pF	50V	UJ	GRM39UJ080D50PT	K22174308	1-	A	D2
C 2016	CHIP CAP.	15pF	50V	CH	GRM39CH150J50PT	K22174215	1-	A	C2
C 2017	CHIP CAP.	0.001uF	50V	B	GRM39B102K50PT	K22174821	1-	A	E1
C 2018	CHIP CAP.	0.001uF	50V	B	GRM39B102K50PT	K22174821	1-	B	d1
C 2019	CHIP CAP.	0.001uF	50V	B	GRM39B102K50PT	K22174821	1-	A	D1
C 2020	CHIP CAP.	0.001uF	50V	B	GRM39B102K50PT	K22174821	1-	B	d1
C 2021	CHIP CAP.	0.001uF	50V	B	GRM39B102K50PT	K22174821	1-	A	C1
C 2022	CHIP CAP.	0.001uF	50V	B	GRM39B102K50PT	K22174821	1-	B	e1
C 2024	CHIP CAP.	0.001uF	50V	B	GRM39B102K50PT	K22174821	1-	B	e2
C 2025	CHIP CAP.	2pF	50V	BJ	GRM39BJ20C50PT	K22174203	1	A	E1
C 2025	CHIP CAP.	3pF	50V	CJ	GRM39CJ030C50PT	K22174204	2-	A	E1
C 2026	CHIP CAP.	2pF	50V	CK	GRM39CK020C50PT	K22174203	1-	A	D1
C 2027	CHIP CAP.	2pF	50V	CK	GRM39CK020C50PT	K22174203	1	A	C1
C 2027	CHIP CAP.	3pF	50V	CJ	GRM39CJ030C50PT	K22174204	2-	A	C1
C 2028	CHIP CAP.	0.001uF	50V	B	GRM39B102K50PT	K22174821	1-	B	d1
C 2029	CHIP CAP.	2pF	50V	AK	GRM39AK20C50PT	K22174203	1-	A	C1
C 2030	CHIP CAP.	0.001uF	50V	B	GRM39B102K50PT	K22174821	1-	A	E1
C 2031	CHIP CAP.	0.001uF	50V	B	GRM39B102K50PT	K22174821	1-	A	D1
C 2032	CHIP CAP.	0.001uF	50V	B	GRM39B102K50PT	K22174821	1-	A	C1
C 2033	CHIP CAP.	0.001uF	50V	B	GRM39B102K50PT	K22174821	1-	A	A1
C 2034	AL.ELECTRO.CAP.	100uF	16V		SMG1CVB101M 100UF	K40129060	1-	A	E2
C 2035	CHIP CAP.	0.001uF	50V	AK	GRM39AK20C50PT	K22174203	1-	B	f2
C 2036	AL.ELECTRO.CAP.	100uF	16V		SMG1CVB101M 100UF	K40129060	1	A	B2
C 2036	AL.ELECTRO.CAP.	1000uF	16V		RE3-16V102MS 1000UF	K40129067	2-	A	B2
C 2036	AL.ELECTRO.CAP.	1000uF	16V		RE3-16V102MH3 1000UF	K40129096	28-	A	B2
C 2037	CHIP CAP.	0.001uF	50V	B	GRM39B102K50PT	K22174821	1-	B	e1
C 2038	CHIP CAP.	0.001uF	50V	B	GRM39B102K50PT	K22174821	1-	B	e1

K Td60.021 Tc 0.0 1 Tc 0.0021uF 0.0 15V 080r21 Tc 0. GRM39B102K50PT B800(4W)100 (B32 070 070) T86td (RE3-16V102MH3 1000UF) Tj 070038.1

Local Unit

REF.	DESCRIPTION	VALUE	V/W	TOL.	MFR'S DESIG	VXSTD P/N	VERS.	LOT.	SIDE	LAY ADR
C 2058	CHIP CAP.	3pF	50V	CJ	GRM39CJ030C50PT	K22174204		1	A	A2
C 2058	CHIP CAP.	2pF	50V	CK	GRM39CK020C50PT	K22174203		2-	A	A2
C 2059	CHIP CAP.	0.0012uF	50V	B	GRM39B122M50PT	K22174810		1	A	G2
C 2059	CHIP CAP.	330pF	50V	B	GRM39B331K50PT	K22174820		2-	A	G2
C 2060	CHIP CAP.	68pF	50V	CH	GRM39CH680J50PT	K22174231		1	A	G2
C 2060	CHIP CAP.	82pF	50V	CH	GRM39CH820J50PT	K22174233		2-	A	G2
C 2061	CHIP CAP.	27pF	50V	CH	GRM39CH270J50PT	K22174221		1-	A	B1
C 2062	CHIP CAP.	22pF	50V	CH	GRM39CH220J50PT	K22174219		1-	A	B1
C 2063	CHIP CAP.	12pF	50V	CH	GRM39CH120J50PT	K22174213		1-	A	B2
C 2064	CHIP CAP.	7pF	50V	CH	GRM39CH070D50PT	K22174208		1-	A	A1
C 2065	CHIP CAP.	680pF	50V	B	GRM39B681M50PT	K22174807		1	A	G2
C 2065	CHIP CAP.	220pF	50V	B	GRM39B221M50PT	K22174801		2-	A	G2
C 2066	CHIP CAP.	0.01uF	25V	B	GRM39B103K25PT	K22144803		1		
C 2067	CHIP CAP.	0.001uF	50V	B	GRM39B102K50PT	K22174821		1-	B	g2
C 2068	CHIP CAP.	0.001uF	50V	B	GRM39B102K50PT	K22174821		1-	A	A1
C 2069	CHIP CAP.	0.001uF	50V	B	GRM39B102K50PT	K22174821		1		
C 2070	CHIP CAP.	0.01uF	25V	B	GRM39B103K25PT	K22144803		1-	B	a2
C 2071	CHIP TA.CAP.	10uF	10V		TEMSVA1A106M-8R	K78100028		1-	B	a2
C 2072	CHIP CAP.	0.001uF	50V	B	GRM39B102K50PT	K22174821		1-	B	f1
C 2073	CHIP CAP.	0.5pF	50V	CK	GRM39CK0R5C50PT	K22174201		1-	A	F2
C 2074	CHIP CAP.	0.001uF	50V	B	GRM39B102K50PT	K22174821		1	B	g1
C 2074	CHIP CAP.	220pF	50V	CH	GRM39CH221J50PT	K22174243		2-	B	g1
C 2075	CHIP CAP.	1pF	50V	CK	GRM39CK010C50PT	K22174202		1	A	F1
C 2076	CHIP CAP.	0.01uF	25V	B	GRM39B103K25PT	K22144803		1	A	F1
C 2076	CHIP CAP.	47pF	50V	CH	GRM39CH470J50PT	K22174227		2-	A	F1
C 2077	CHIP CAP.	0.1uF	25V	F	GRM39F104Z25PT	K22145001		1-	A	F3
C 2078	CHIP CAP.	0.1uF	25V	F	GRM39F104Z25PT	K22145001		1-	B	b1
C 2079	CHIP CAP.	0.1uF	25V	F	GRM39F104Z25PT	K22145001		1-	A	E2
C 2080	CHIP CAP.	0.001uF	50V	B	GRM39B102K50PT	K22174821		1		
C 2081	CHIP CAP.	0.01uF	25V	B	GRM39B103K25PT	K22144803		1-	B	b1
C 2082	CHIP TA.CAP.	10uF	10V		TEMSVA1A106M-8R	K78100028		1-	B	b1
C 2084	CHIP CAP.	560pF	50V	B	GRM39B561M50PT	K22174806		1-	B	b1
C 2085	CHIP CAP.	56pF	50V	CH	GRM39CH560J50PT	K22174229		1-	B	b1
C 2086	CHIP CAP.	0.1uF	25V	F	GRM39F104Z25PT	K22145001		1-	A	E2
C 2087	CHIP CAP.	0.001uF	50V	B	GRM39B102K50PT	K22174821		1-	B	g2
C 2088	CHIP CAP.	22pF	50V	CH	GRM39CH220J50PT	K22174219		1	A	A2
C 2088	CHIP CAP.	33pF	50V	CH	GRM39CH330J50PT	K22174223		2-	A	A2
C 2089	CHIP CAP.	0.0012uF	50V	B	GRM39B122M50PT	K22174810		1-	B	b1
C 2090	CHIP CAP.	150pF	50V	CH	GRM39CH151J50PT	K22174239		1-	B	b1
C 2091	CHIP CAP.	0.1uF	25V	F	GRM39F104Z25PT	K22145001		1-	A	G1
C 2092	CHIP CAP.	0.001uF	50V	B	GRM39B102K50PT	K22174821		1-	B	g1
C 2093	CHIP CAP.	3pF	50V	CJ	GRM39CJ030C50PT	K22174204		1	A	A2
C 2093	CHIP CAP.	2pF	50V	CK	GRM39CK020C50PT	K22174203		2-	A	A2
C 2094	CHIP CAP.	390pF	50V	CH	GRM39CH391J50PT	K22174255		1-	B	b1
C 2095	CHIP TA.CAP.	2.2uF	10V		TESVA1A225M1-8R	K78100021		1-	A	G1
C 2096	CHIP CAP.	0.1uF	25V	F	GRM39F104Z25PT	K22145001		1-	B	b2
C 2097	CHIP CAP.	0.1uF	25V	F	GRM39F104Z25PT	K22145001		1-	A	E3
C 2098	CHIP CAP.	12pF	50V	CH	GRM39CH120J50PT	K22174213		1	A	A2
C 2098	CHIP CAP.	22pF	50V	CH	GRM39CH220J50PT	K22174219		2-	A	A2
C 2099	CHIP CAP.	0.01uF	25V	B	GRM39B103K25PT	K22144803		1-	A	G1
C 2100	CHIP CAP.	0.01uF	25V	B	GRM39B103K25PT	K22144803		1-	A	G1
C 2101	CHIP CAP.	0.001uF	50V	B	GRM39B102K50PT	K22174821		1-	A	A2
C 2102	CHIP TA.CAP.	10uF	10V		TEMSVA1A106M-8R	K78100028		1-	B	b2
C 2103	CHIP CAP.	100pF	50V	CH	GRM39CH101J50PT	K22174235		1-	A	E2
C 2104	CHIP CAP.	0.001uF	50V	B	GRM39B102K50PT	K22174821		1-	A	A1
C 2105	CHIP CAP.	0.001uF	50V	B	GRM39B102K50PT	K22174821		1-	A	A1
C 2106	CHIP CAP.	0.001uF	50V	B	GRM39B102K50PT	K22174821		1-	B	e2
C 2107	CHIP CAP.	0.001uF	50V	B	GRM39B102K50PT	K22174821		1-	A	E1
C 2108	CHIP CAP.	3pF	50V	CJ	GRM39CJ030C50PT	K22174204		1	A	A1
C 2108	CHIP CAP.	4pF	50V	CH	GRM39CH040C50PT	K22174205		2-	A	A1
C 2109	CHIP CAP.	7pF	50V	CH	GRM39CH070D50PT	K22174208		1-	A	A1
C 2110	CHIP CAP.	100pF	50V	CH	GRM39CH101J50PT	K22174235		1-	B	a1
C 2111	CHIP CAP.	3pF	50V	CJ	GRM39CJ030C50PT	K22174204		1	A	A1
C 2111	CHIP CAP.	4pF	50V	CH	GRM39CH040C50PT	K22174205		2-	A	A1
C 2112	CHIP CAP.	7pF	50V	CH	GRM39CH070D50PT	K22174208		1-	A	A1
C 2113	CHIP CAP.	0.01uF	25V	B	GRM39B103K25PT	K22144803		1-	A	F1
C 2114	CHIP CAP.	0.01uF	25V	B	GRM39B103K25PT	K22144803		1-	B	c1
C 2115	CHIP CAP.	5pF	50V	CH	GRM39CH050C50PT	K22174206		1	B	c1

Local Unit

REF.	DESCRIPTION	VALUE	V/W	TOL.	MFR'S DESIG	VXSTD P/N	VERS.	LOT.	SIDE	LAY ADR
C 2115	CHIP CAP.	22pF	50V	CH	GRM39CH220J50PT	K22174219		2-	B	c1
C 2116	CHIP CAP.	3pF	50V	CJ	GRM39CJ030C50PT	K22174204		1	A	A1
C 2116	CHIP CAP.	4pF	50V	CH	GRM39CH040C50PT	K22174205		2-	A	A1
C 2117	CHIP CAP.	7pF	50V	CH	GRM39CH070D50PT	K22174208		1-	A	A1
C 2118	CHIP CAP.	1pF	50V	CK	GRM39CK010C50PT	K22174202		1	A	G1
C 2118	CHIP CAP.	0.5pF	50V	CK	GRM39CK0R5C50PT	K22174201		2-	A	G1
C 2119	CHIP CAP.	2pF	50V	CK	GRM39CK020C50PT	K22174203		1	B	c1
C 2119	CHIP CAP.	0.5pF	50V	CK	GRM39CK0R5C50PT	K22174201		2-	B	c1
C 2120	CHIP CAP.	0.001uF	50V	B	GRM39B102K50PT	K22174821		1-	A	A1
C 2121	CHIP CAP.	0.001uF	50V	B	GRM39B102K50PT	K22174821		1-	A	A1
C 2122	CHIP CAP.	5pF	50V	CH	GRM39CH050C50PT	K22174206		1	A	F1
C 2122	CHIP CAP.	27pF	50V	CH	GRM39CH270J50PT	K22174221		2-	A	F1
C 2123	CHIP CAP.	0.01uF	25V	B	GRM39B103K25PT	K22144803		1	B	b1
C 2123	CHIP CAP.	18pF	50V	CH	GRM39CH180J50PT	K22174217		2-	B	b1
C 2124	CHIP CAP.	0.01uF	25V	B	GRM39B103K25PT	K22144803		1-	B	c1
C 2125	CHIP CAP.	0.001uF	50V	B	GRM39B102K50PT	K22174821		1-	B	h2
C 2126	CHIP CAP.	0.001uF	50V	B	GRM39B102K50PT	K22174821		1-	A	B1
C 2127	CHIP CAP.	0.001uF	50V	B	GRM39B102K50PT	K22174821		1-	A	B1
C 2128	CHIP CAP.	0.001uF	50V	B	GRM39B102K50PT	K22174821		1-	A	B2
C 2129	CHIP CAP.	0.001uF	50V	B	GRM39B102K50PT	K22174821		1-	B	d2
C 2130	CHIP CAP.	0.001uF	50V	B	GRM39B102K50PT	K22174821		1-	B	g2
C 2131	CHIP CAP.	82pF	50V	CH	GRM39CH820J50PT	K22174233		1-	B	b1
C 2132	CHIP CAP.	82pF	50V	CH	GRM39CH820J50PT	K22174233		1-	A	G1
C 2133	CHIP CAP.	0.01uF	25V	B	GRM39B103K25PT	K22144803		1-	A	F1
C 2134	CHIP CAP.	0.01uF	25V	B	GRM39B103K25PT	K22144803		1-	A	F1
C 2135	CHIP CAP.	0.001uF	50V	B	GRM39B102K50PT	K22174821		1		
C 2136	CHIP CAP.	0.01uF	25V	B	GRM39B103K25PT	K22144803		1-	A	E2
C 2137	CHIP CAP.	15pF	50V	CH	GRM39CH150J50PT	K22174215		1-	A	E2
C 2138	CHIP CAP.	0.01uF	25V	B	GRM39B103K25PT	K22144803		1-	A	E1
C 2139	CHIP CAP.	0.01uF	25V	B	GRM39B103K25PT	K22144803		1		
C 2140	CHIP CAP.	100pF	50V	CH	GRM39CH101J50PT	K22174235		1		
C 2141	CHIP CAP.	0.001uF	50V	B	GRM39B102K50PT	K22174821		1-	B	h1
C 2142	CHIP CAP.	0.001uF	50V	B	GRM39B102K50PT	K22174821		1-	B	h2
C 2143	CHIP CAP.	0.01uF	25V	B	GRM39B103K25PT	K22144803		1-	B	b1
C 2144	CHIP CAP.	0.01uF	25V	B	GRM39B103K25PT	K22144803		1-	B	b1
C 2145	CHIP CAP.	0.01uF	25V	B	GRM39B103K25PT	K22144803		1	B	c1
C 2145	CHIP CAP.	0.01uF	25V	B	GRM39B103K25PT	K22144803		2-	B	c1
C 2146	CHIP CAP.	0.01uF	25V	B	GRM39B103K25PT	K22144803		1	B	c1
C 2146	CHIP CAP.	39pF	50V	CH	GRM39CH390J50PT	K22174225		2-	B	c1
C 2147	CHIP CAP.	2pF	50V	CK	GRM39CK020C50PT	K22174203		1-	A	E1
C 2148	CHIP CAP.	2pF	50V	CK	GRM39CK020C50PT	K22174203		1-	A	D1
C 2150	CHIP CAP.	7pF	50V	CH	GRM39CH070D50PT	K22174208		1	B	d1
C 2150	CHIP CAP.	12pF	50V	CH	GRM39CH120J50PT	K22174213		2-	B	d1
C 2151	CHIP CAP.	0.022uF	25V	B	GRM39B223K25PT	K22144807		1	B	e2
C 2151	CHIP TA.CAP.	0.047uF	35V		TESVA1V473M1-8R	K78160023		2-	B	e2
C 2153	CHIP CAP.	22pF	50V	CH	GRM39CH220J50PT	K22174219		1-	A	B1
C 2154	CHIP CAP.	15pF	50V	CH	GRM39CH150J50PT	K22174215		1-	A	B1
C 2155	CHIP CAP.	10pF	50V	CH	GRM39CH100D50PT	K22174211		1-	A	B2
C 2156	CHIP CAP.	8pF	50V	CH	GRM39CH080D50PT	K22174209		1-	A	B1
C 2157	CHIP CAP.	5pF	50V	CH	GRM39CH050C50PT	K22174206		1-	A	B1
C 2158	CHIP CAP.	3pF	50V	CJ	GRM39CJ030C50PT	K22174204		1-	A	B2
C 2159	CHIP CAP.	0.5pF	50V	CK	GRM39CK0R5C50PT	K22174201		1		
C 2160	CHIP CAP.	0.5pF	50V	CK	GRM39CK0R5C50PT	K22174201		1		
C 2161	CHIP CAP.	0.5pF	50V	CK	GRM39CK0R5C50PT	K22174201		1		
C 2162	AL.ELECTRO.CAP.	100uF	16V		SMG1CVB101M 100UF	K40129060		1	A	D3
C 2162	AL.ELECTRO.CAP.	1000uF	16V		RE3-16V102MS 1000UF	K40129067		2-	A	D3
C 2162	AL.ELECTRO.CAP.	1000uF	16V		RE3-16V102MH3 1000UF	K40129096		28-	A	D3
C 2163	AL.ELECTRO.CAP.	100uF	16V		SMG1CVB101M 100UF	K40129060		1-	A	E1
C 2164	CHIP CAP.	100pF	50V	CH	GRM39CH101J50PT	K22174235		1	A	C3
C 2164	CHIP CAP.	10pF	50V	CH	GRM39CH100D50PT	K22174211		2-	A	C3
C 2165	CHIP CAP.	100pF	50V	CH	GRM39CH101J50PT	K22174235		1	A	C2
C 2165	CHIP CAP.	10pF	50V	CH	GRM39CH100D50PT	K22174211		2-	A	C2
C 2166	CHIP CAP.	100pF	50V	CH	GRM39CH101J50PT	K22174235		1	A	C2
C 2166	CHIP CAP.	10pF	50V	CH	GRM39CH100D50PT	K22174211		2-	A	C2
C 2167	CHIP CAP.	100pF	50V	CH	GRM39CH101J50PT	K22174235		1	B	c2
C 2167	CHIP CAP.	10pF	50V	CH	GRM39CH100D50PT	K22174211		2-	B	c2
C 2168	CHIP CAP.	100pF	50V	CH	GRM39CH101J50PT	K22174235		1	B	c2
C 2168	CHIP CAP.	10pF	50V	CH	GRM39CH100D50PT	K22174211		2-	B	c2

Local Unit

REF.	DESCRIPTION	VALUE	V/W	TOL.	MFR'S DESIG	VXSTD P/N	VERS.	LOT.	SIDE	LAY ADR
C 2169	CHIP CAP.	100pF	50V	CH	GRM39CH101J50PT	K22174235		1	B	c2
C 2169	CHIP CAP.	10pF	50V	CH	GRM39CH100D50PT	K22174211		2-	B	c2
C 2170	CHIP CAP.	100pF	50V	CH	GRM39CH101J50PT	K22174235		1	B	a2
C 2170	CHIP CAP.	10pF	50V	CH	GRM39CH100D50PT	K22174211		2-	B	a2
C 2171	CHIP CAP.	100pF	50V	CH	GRM39CH101J50PT	K22174235		1	B	a2
C 2171	CHIP CAP.	10pF	50V	CH	GRM39CH100D50PT	K22174211		2-	B	a2
C 2172	CHIP CAP.	100pF	50V	CH	GRM39CH101J50PT	K22174235		1	B	a2
C 2172	CHIP CAP.	10pF	50V	CH	GRM39CH100D50PT	K22174211		2-	B	a2
C 2173	CHIP TA.CAP.	2.2uF	16V		TEMSVA21C225M-8R	K78120030		1-	B	e3
C 2174	CHIP CAP.	0.001uF	50V	B	GRM39B102K50PT	K22174821		1	B	f1
C 2174	CHIP CAP.	0.001uF	50V	B	GRM39B102K50PT	K22174821		2-	B	f1
C 2175	CERAMIC CAP.	15pF	50V	CH	DD104CH150J50	K02175150		1	A	E2
C 2175	CHIP CAP.	15pF	50V	CH	GRM39CH150J50PT	K22174215		2-	A	E2
C 2176	CHIP CAP.	8pF	50V	UJ	GRM39UJ080D50PT	K22174308		1-	A	E2
C 2177	CHIP CAP.	0.001uF	50V	B	GRM39B102K50PT	K22174821		1-	B	d2
C 2178	CHIP TA.CAP.	10uF	6.3V		TESVSP0J106M-8R	K78080055		2-	B	e3
C 2179	CHIP CAP.	0.1uF	25V	F	GRM39F104Z25PT	K22145001		2-	B	f1
C 2180	CHIP CAP.	0.01uF	25V	B	GRM39B103K25PT	K22144803		2-	B	g1
C 2181	CHIP CAP.	0.01uF	25V	B	GRM39B103K25PT	K22144803		2-	B	f2
C 2182	CHIP CAP.	0.1uF	25V	F	GRM39F104Z25PT	K22145001		2-	B	f2
C 2184	CHIP CAP.	12pF	50V	CH	GRM39CH120J50PT	K22174213		2-	A	F2
C 2186	CHIP CAP.	7pF	50V	CH	GRM39CH070D50PT	K22174208		2-	A	B2
C 2187	CHIP CAP.	7pF	50V	CH	GRM39CH070D50PT	K22174208		2-	A	A2
C 2188	CHIP CAP.	0.001uF	50V	B	GRM39B102K50PT	K22174821		2-	A	A2
C 2189	CHIP CAP.	39pF	50V	CH	GRM39CH390J50PT	K22174225		2-	B	c1
C 2197	AL.ELECTRO.CAP.	220uF	10V		SMG1AVB221M 220UF	K40109027		2-		
D 2001	DIODE				HVU306A5TRF	G2070132		1-	B	d1
D 2002	DIODE				HVU306A5TRF	G2070132		1-	B	e1
D 2003	DIODE				HVU306A5TRF	G2070132		1-	B	f1
D 2004	DIODE				HVU306A5TRF	G2070132		1-	B	d1
D 2005	DIODE				HVU306A5TRF	G2070132		1-	B	e1
D 2006	DIODE				HVU306A5TRF	G2070132		1-	B	f1
D 2007	DIODE				HVU306A5TRF	G2070132		1-	B	d2
D 2008	DIODE				HVU306A5TRF	G2070132		1-	B	e2
D 2009	DIODE				HVU306A5TRF	G2070132		1-	B	d1
D 2010	DIODE				HVU306A5TRF	G2070132		1-	B	d1
D 2011	DIODE				HVU306A5TRF	G2070132		1-	B	e1
D 2012	DIODE				HVU306A5TRF	G2070132		1-	B	e1
D 2013	DIODE				HVU306A5TRF	G2070132		1-	B	f1
D 2014	DIODE				HVU306A5TRF	G2070132		1-	B	f1
D 2015	DIODE				HVU306A5TRF	G2070132		1-	B	f2
D 2016	DIODE				HVU306A5TRF	G2070132		1-	B	d2
D 2020	DIODE				DAP236U T106	G2070592		1-	B	f1
D 2021	DIODE				DAP236U T106	G2070592		1-	B	f1
D 2025	DIODE				DAP236U T106	G2070592		1-	A	B1
D 2026	DIODE				DAP236U T106	G2070592		1-	A	B2
D 2027	DIODE				DAN202U T106	G2070162		1-	B	h2
D 2028	DIODE				DAP236U T106	G2070592		1		
D 2029	DIODE				DAP236U T106	G2070592		1-	A	B1
D 2030	DIODE				DAP236U T106	G2070592		1-	A	A1
D 2031	DIODE				DAP236U T106	G2070592		1-	A	A2
D 2032	DIODE				DAP236U T106	G2070592		1-	A	B1
D 2033	DIODE				DAP236U T106	G2070592		1-	A	A1
D 2035	DIODE				HVU306A5TRF	G2070132		1-	B	d2
D 2036	DIODE				HVU306A5TRF	G2070132		1	B	d2
D 2037	DIODE				HVU306A5TRF	G2070132		1-	B	e2
D 2039	DIODE				HVU306A5TRF	G2070132		1-	B	f2
D 2041	DIODE				DAN202U T106	G2070162		2-	B	g2
D 2042	DIODE				DAN202U T106	G2070162		2-	B	g2
D 2043	DIODE				DAN202U T106	G2070162		1-	B	g2
D 2044	DIODE				DAN202U T106	G2070162		1-	B	g2
D 2045	DIODE				DAN202U T106	G2070162		1-	B	e2
D 2046	DIODE				DAN202U T106	G2070162		1-	B	f2
D 2047	DIODE				DAN202U T106	G2070162		1-	B	g2
D 2048	DIODE				DAN202U T106	G2070162		1	A	C3
D 2048	DIODE				DAP202U T106	G2070160		2-	A	C3
D 2049	DIODE				DAN202U T106	G2070162		1-	B	f2
D 2050	DIODE				GMB01-BT	G2060016		1		

Local Unit

REF.	DESCRIPTION	VALUE	V/W	TOL.	MFR'S DESIG	VXSTD P/N	VERS.	LOT.	SIDE	LAY ADR
D 2051	DIODE				GMB01-BT	G2060016		1		
D 2052	DIODE				GMB01-BT	G2060016		1		
D 2053	DIODE				GMB01-BT	G2060016		1		
D 2054	DIODE				DAP236U T106	G2070592		2-	B	g2
D 2055	DIODE				DAP236U T106	G2070592		2-	B	f1
J 2002	CONNECTOR				12FMZ-BT	P1090901		1-	A	D3
J 2003	CONNECTOR				TMP-J01X-A2	P1090255		1-	A	A1
J 2004	CONNECTOR				TMP-J01X-A2	P1090255		1-	A	G1
J 2005	CONNECTOR				TMP-J01X-A2	P1090255		1-	A	F1
J 2006	CONNECTOR				3022-04B	P0090523		1-	A	E2
J 2007	TERMINAL				OT-007	S5000180		1-	A	G2
JP2001	WIRE ASSY				A0898 #241896	T9206727		1		
JP2001	WIRE ASSY				A0898	T9206730		2-		
JP2003	WIRE ASSY				A0898	T9206730		1		
JP2003	WIRE ASSY				A0898 #241896	T9206727		2-		
L 2001	CHIP COIL	0.47uH			C2520C-R47J	L1690552		1-	A	D1
L 2002	CHIP COIL	0.47uH			C2520C-R47J	L1690552		1-	A	D1
L 2003	CHIP COIL	0.47uH			C2520C-R47J	L1690552		1-	A	C1
L 2004	CHIP COIL	0.47uH			C2520C-R47J	L1690552		1-	A	D1
L 2005	CHIP COIL	0.47uH			C2520C-R47J	L1690552		1-	A	C1
L 2006	CHIP COIL	0.47uH			C2520C-R47J	L1690552		1-	A	D1
L 2007	CHIP COIL	0.47uH			C2520C-R47J	L1690552		1-	A	D1
L 2008	CHIP COIL	0.47uH			C2520C-R47J	L1690552		1-	A	C1
L 2009	CHIP COIL	0.47uH			C2520C-R47J	L1690552		1-	A	D1
L 2010	CHIP COIL	0.47uH			C2520C-R47J	L1690552		1-	A	D2
L 2011	CHIP COIL	0.47uH			C2520C-R47J	L1690552		1-	A	D2
L 2012	COIL				S5-C 2.5T RED	L0190234		1-	A	C2
L 2013	CHIP COIL	0.47uH			C2520C-R47J	L1690552		1-	A	C2
L 2014	COIL				S5-C 3.5T ORG	L0190235		1-	A	D2
L 2015	COIL				S5-C 6.5T BLU	L0190238		1-	A	D1
L 2016	COIL				S5-C 6.5T BLU	L0190238		1-	A	D1
L 2017	COIL				S5-C 5.5T GRN	L0190237		1-	A	C1
L 2018	CHIP COIL	0.47uH			C2520C-R47J	L1690552		1-	A	E1
L 2019	CHIP COIL	0.47uH			C2520C-R47J	L1690552		1-	A	D1
L 2020	CHIP COIL	0.47uH			C2520C-R47J	L1690552		1-	A	C1
L 2021	COIL				S5-C 3.5T ORG	L0190235		1	A	E2
L 2021	COIL				S5-C 3.5T ORG R12-T103X	L0190242		2-	A	E2
L 2021	COIL				S5-C 3.5T ORG	L0190235		5-	A	E2
L 2022	CHIP COIL	0.47uH			C2520C-R47J	L1690552		1-	A	C2
L 2023	CHIP COIL	0.068uH			LQN21A68NJ04	L1690605		1-	A	E1
L 2024	CHIP COIL	0.068uH			LQN21A68NJ04	L1690605		1-	A	D1
L 2025	CHIP COIL	0.033uH			LQN21A33NJ04	L1690615		1-	A	C1
L 2026	M.RFC	0.012uH			ELJ-RE12NJF2	L1690715		1-	A	B1
L 2027	M.RFC	2.2uH			LK2125 2R2K-T	L1690323		1-	B	e1
L 2028	M.RFC	0.015uH			ELJ-RE15NJF2	L1690716		1	A	A2
L 2028	M.RFC	0.0068uH			ELJ-RE6N8JF2	L1690712		2-	A	A2
L 2029	M.RFC	0.0068uH			ELJ-RE6N8JF2	L1690712		1-	A	A1
L 2030	CHIP COIL	0.056uH			C2520C-56NK	L1690541		1-	A	B1
L 2031	CHIP COIL	0.039uH			C2520C-39NK	L1690539		1-	A	B1
L 2032	CHIP COIL	0.027uH			C2520C-27NK	L1690537		1-	A	B2
L 2033	M.RFC	0.047uH			ELJ-RE47NJF2	L1690722		1	A	A2
L 2033	M.RFC	0.082uH			ELJ-RE82NJF3	L1690725		2-	A	A2
L 2034	M.RFC	1.8uH			LK2125 1R8K-T	L1690322		1	A	G2
L 2034	M.RFC	5.6uH			LK2125 5R6K-T	L1690328		2-	A	G2
L 2035	CHIP COIL	0.082uH			C2520C-82NK	L1690543		1-	A	B1
L 2036	CHIP COIL	0.056uH			C2520C-56NK	L1690541		1-	A	B1
L 2037	CHIP COIL	0.039uH			C2520C-39NK	L1690539		1-	A	B2
L 2038	M.RFC	0.0068uH			ELJ-RE6N8JF2	L1690712		1-	A	A1
L 2039	M.RFC	2.2uH			LK2125 2R2K-T	L1690323		1	A	G2
L 2039	M.RFC	4.7uH			LK2125 4R7K-T	L1690327		2-	A	G2
L 2040	M.RFC	0.0082uH			ELJ-RE8N2JF2	L1690713		1	A	A2
L 2040	M.RFC	0.0039uH			ELJ-RE3N9JF2	L1690709		2-	A	A2
L 2041	M.RFC	100uH			FLC32T-101J	L1690227		1-	A	H2
L 2042	M.RFC	100uH			FLC32T-101J	L1690227		1-	A	G1
L 2043	M.RFC	100uH			FLC32T-101J	L1690227		1-	A	G2
L 2044	M.RFC	1.8uH			LK2125 1R8K-T	L1690322		1-	B	b1
L 2045	M.RFC	0.012uH			ELJ-RE12NJF2	L1690715		1-	A	A1
L 2046	M.RFC	1.5uH			LK2125 1R5K-T	L1690321		1-	B	b1

Local Unit

REF.	DESCRIPTION	VALUE	V/W	TOL.	MFR'S DESIG	VXSTD P/N	VERS.	LOT.	SIDE	LAY ADR
L 2047	M.RFC	0.047uH			ELJ-RE47NJF2	L1690722		1	A	A2
L 2047	M.RFC	0.082uH			ELJ-RE82NJF3	L1690725		2-	A	A2
L 2048	M.RFC	100uH			FLC32T-101J	L1690227		1-	A	G2
L 2049	M.RFC	0.0068uH			ELJ-RE6N8JF2	L1690712		1-	A	B1
L 2050	M.RFC	0.01uH			ELJ-RE10NJF2	L1690714		1-	A	B1
L 2051	M.RFC	0.0033uH			ELJ-RE3N3DF2	L1690708		1-	A	A1
L 2052	M.RFC	0.0047uH			ELJ-RE4N7JF2	L1690710		1-	A	A1
L 2053	M.RFC	0.015uH			ELJ-RE15NJF2	L1690716		1	A	A2
L 2053	M.RFC	0.0068uH			ELJ-RE6N8JF2	L1690712		2-	A	A2
L 2054	CHIP COIL	0.47uH			C2520C-R47J	L1690552		1-	A	D2
L 2055	CHIP COIL	0.47uH			C2520C-R47J	L1690552		1-	A	E2
L 2057	M.RFC	0.0033uH			ELJ-RE3N3DF2	L1690708		1-	A	A1
L 2058	M.RFC	0.0047uH			ELJ-RE4N7JF2	L1690710		1-	A	A1
L 2059	M.RFC	0.0068uH			ELJ-RE6N8JF2	L1690712		1-	A	A1
L 2060	M.RFC	0.01uH			ELJ-RE10NJF2	L1690714		1-	A	A1
L 2061	M.RFC	2.2uH			LK2125 2R2K-T	L1690323		1-	B	d2
L 2062	M.RFC	0.33uH			LK2125 R33K-T	L1690313		1-	A	A2
L 2063	M.RFC	0.015uH			ELJ-RE15NJF2	L1690716		2-	A	B2
L 2064	M.RFC	0.22uH			LAL02NAR22M	L1190275		2	A	F1
L 2064	M.RFC	0.22uH			LAP02KRR22M	L1190342		3-	A	F1
Q 2003	FET				2SK508-T2B K52	G3805087B		1-	A	D2
Q 2004	FET				2SK508-T2B K52	G3805087B		1-	A	C2
Q 2005	FET				2SK508-T2B K52	G3805087B		1-	A	D1
Q 2006	FET				2SK508-T2B K52	G3805087B		1-	A	D1
Q 2007	FET				2SK508-T2B K52	G3805087B		1-	A	C1
Q 2008	IC				FQ7925	G1091710		1-	A	C2
Q 2009	TRANSISTOR				DTC114EU T106	G3070084		1-	B	d1
Q 2010	TRANSISTOR				DTC114EU T106	G3070084		1-	B	e1
Q 2011	TRANSISTOR				DTC114EU T106	G3070084		1-	B	e1
Q 2012	FET				2SK508-T2B K52	G3805087B		1-	A	D1
Q 2013	TRANSISTOR				DTC114EU T106	G3070084		1-	B	e2
Q 2014	TRANSISTOR				2SC3356-T2B	G3333567		1-	B	e1
Q 2015	TRANSISTOR				DTC114EU T106	G3070084		1-	B	f1
Q 2016	TRANSISTOR				DTC114EU T106	G3070084		1-	B	d2
Q 2017	TRANSISTOR				DTC114EU T106	G3070084		1-	B	f1
Q 2019	TRANSISTOR				DTC114EU T106	G3070084		1-	B	d2
Q 2020	IC				MC14028BFL	G1090998		1-	A	B2
Q 2021	IC				UPC1688G-T1	G1092286		1-	B	f2
Q 2023	TRANSISTOR				DTC114EU T106	G3070084		1-	B	f2
Q 2024	IC				UPC1688G-T1	G1092286		1-	B	f1
Q 2025	IC				AD9850BRS-REEL	G1092567		1-	A	G2
Q 2026	TRANSISTOR				DTC114EU T106	G3070084		1-	B	g2
Q 2027	IC				FQ7928	G1092005		1-	A	F2
Q 2028	TRANSISTOR				2SC2812L6-TA	G3328127F		1-	A	F1
Q 2028	TRANSISTOR				2SC2812NL6-TB	G3328128F		19-	A	F1
Q 2031	IC				UPC1688G-T1	G1092286		1-	B	g1
Q 2034	TRANSISTOR				2SC2812L6-TA	G3328127F		1-	A	E2
Q 2034	TRANSISTOR				2SC2812NL6-TB	G3328128F		19-	A	E2
Q 2036	TRANSISTOR				2SC2812L6-TA	G3328127F		1-	A	F1
Q 2036	TRANSISTOR				2SC2812NL6-TB	G3328128F		19-	A	F1
Q 2037	TRANSISTOR				2SC2812L6-TA	G3328127F		1	A	E1
Q 2037	TRANSISTOR				2SC2759-T2B U23	G3327597C		2-	A	E1
Q 2038	TRANSISTOR				2SC2812L6-TA	G3328127F		1-	A	H1
Q 2038	TRANSISTOR				2SC2812NL6-TB	G3328128F		19-	A	H1
Q 2039	TRANSISTOR				2SC2812L6-TA	G3328127F		1-	A	E1
Q 2039	TRANSISTOR				2SC2812NL6-TB	G3328128F		19-	A	E1
Q 2040	TRANSISTOR				2SC2812L6-TA	G3328127F		1-	A	E2
Q 2040	TRANSISTOR				2SC2812NL6-TB	G3328128F		19-	A	E2
Q 2041	TRANSISTOR				2SC2812L6-TA	G3328127F		1		
Q 2042	TRANSISTOR				DTC114EU T106	G3070084		1-	B	g2
Q 2043	IC				UPC1679G-E(TAPING)	G1092714		1-	A	A2
Q 2044	TRANSISTOR				2SC2812L6-TA	G3328127F		1-	B	b1
Q 2044	TRANSISTOR				2SC2812NL6-TB	G3328128F		19-	B	b1
Q 2045	TRANSISTOR				2SC2812L6-TA	G3328127F		1-	B	c1
Q 2045	TRANSISTOR				2SC2812NL6-TB	G3328128F		19-	B	c1
Q 2046	TRANSISTOR				UMH11N TN	G3070212		1-	B	g1
Q 2047	TRANSISTOR				UMH11N TN	G3070212		1-	B	g2
Q 2048	TRANSISTOR				UMD3N TR	G3070211		1-	B	g2

Local Unit

REF.	DESCRIPTION	VALUE	V/W	TOL.	MFR'S DESIG	VXSTD P/N	VERS.	LOT.	SIDE	LAY ADR
Q 2049	TRANSISTOR				UMD3N TR	G3070211		1-	B	g2
Q 2050	TRANSISTOR				UMD3N TR	G3070211		1-	B	g2
Q 2051	TRANSISTOR				UMD3N TR	G3070211		1-	B	h2
Q 2052	TRANSISTOR				2SC2812L6-TA	G3328127F		2-	B	d2
Q 2052	TRANSISTOR				2SC2812NL6-TB	G3328128F		19-	B	d2
R 2001	CHIP RES.	100	1/16W	5%	RMC1/16 101JATP	J24185101		1-	B	d1
R 2002	CHIP RES.	100	1/16W	5%	RMC1/16 101JATP	J24185101		1-	B	e1
R 2003	CHIP RES.	100	1/16W	5%	RMC1/16 101JATP	J24185101		1-	B	f1
R 2004	CHIP RES.	100	1/16W	5%	RMC1/16 101JATP	J24185101		1-	B	d1
R 2005	CHIP RES.	100	1/16W	5%	RMC1/16 101JATP	J24185101		1-	B	f1
R 2006	CHIP RES.	1.8k	1/16W	5%	RMC1/16 182JATP	J24185182		1-	A	C2
R 2008	CHIP RES.	1k	1/16W	5%	RMC1/16 102JATP	J24185102		1-	A	C2
R 2011	CHIP RES.	3.3k	1/16W	5%	RMC1/16 332JATP	J24185332		1	A	C2
R 2011	CHIP RES.	5.6k	1/16W	5%	RMC1/16 562JATP	J24185562		2	A	C2
R 2012	CHIP RES.	150	1/16W	5%	RMC1/16 151JATP	J24185151		1	B	d1
R 2012	CHIP RES.	100	1/16W	5%	RMC1/16 101JATP	J24185101		2-	B	d1
R 2013	CHIP RES.	150	1/16W	5%	RMC1/16 151JATP	J24185151		1-	B	d1
R 2014	CHIP RES.	150	1/16W	5%	RMC1/16 151JATP	J24185151		1-	B	e1
R 2015	CHIP RES.	100	1/16W	5%	RMC1/16 101JATP	J24185101		1-	B	e1
R 2016	CHIP RES.	150	1/16W	5%	RMC1/16 151JATP	J24185151		1-	B	e2
R 2017	CHIP RES.	0	1/16W	5%	RMC1/16 000JATP	J24185000		1-	A	C2
R 2018	CHIP RES.	100	1/16W	5%	RMC1/16 101JATP	J24185101		1-	B	d2
R 2019	CHIP RES.	68	1/16W	5%	RMC1/16 680JATP	J24185680		1		
R 2020	CHIP RES.	33	1/10W	5%	RMC1/10T 330J	J24205330		1	B	f2
R 2020	CHIP RES.	33	1/10W	5%	RMC1/10T 330J	J24205330		2-	B	f2
R 2021	CHIP RES.	10k	1/16W	5%	RMC1/16 103JATP	J24185103		1-	B	e1
R 2022	CHIP RES.	3.3k	1/16W	5%	RMC1/16 332JATP	J24185332		1-	B	e1
R 2023	CHIP RES.	10	1/16W	5%	RMC1/16 100JATP	J24185100		1		
R 2024	CHIP RES.	100	1/16W	5%	RMC1/16 101JATP	J24185101		1		
R 2025	CHIP RES.	100	1/16W	5%	RMC1/16 101JATP	J24185101		1-	B	e1
R 2026	CHIP RES.	470	1/16W	5%	RMC1/16 471JATP	J24185471		1-	B	f1
R 2027	CHIP RES.	10	1/16W	5%	RMC1/16 100JATP	J24185100		1		
R 2028	CHIP RES.	150	1/16W	5%	RMC1/16 151JATP	J24185151		1-	B	d2
R 2029	CHIP RES.	1k	1/10W	5%	RMC1/10T 102J	J24205102		1-	B	f1
R 2030	CHIP RES.	100	1/16W	5%	RMC1/16 101JATP	J24185101		1-	B	e3
R 2031	CHIP RES.	1k	1/10W	5%	RMC1/10T 102J	J24205102		1-	B	f1
R 2032	CHIP RES.	1k	1/10W	5%	RMC1/10T 102J	J24205102		1-	B	f1
R 2033	CHIP RES.	1k	1/10W	5%	RMC1/10T 102J	J24205102		1-	B	f1
R 2034	CHIP RES.	22	1/16W	5%	RMC1/16 220JATP	J24185220		1	A	B1
R 2034	CHIP RES.	10	1/16W	5%	RMC1/16 100JATP	J24185100		2-	A	B1
R 2035	CHIP RES.	22	1/16W	5%	RMC1/16 220JATP	J24185220		1	A	B1
R 2035	CHIP RES.	10	1/16W	5%	RMC1/16 100JATP	J24185100		2-	A	B1
R 2036	CHIP RES.	22	1/16W	5%	RMC1/16 220JATP	J24185220		1	A	B2
R 2036	CHIP RES.	10	1/16W	5%	RMC1/16 100JATP	J24185100		2-	A	B2
R 2037	CHIP RES.	150	1/16W	5%	RMC1/16 151JATP	J24185151		1-	B	d1
R 2038	CHIP RES.	180	1/10W	5%	RMC1/10T 181J	J24205181		1-	B	g2
R 2039	CHIP RES.	39	1/16W	5%	RMC1/16 390JATP	J24185390		1	A	B1
R 2039	CHIP RES.	150	1/16W	5%	RMC1/16 151JATP	J24185151		2-	A	B1
R 2040	CHIP RES.	39	1/16W	5%	RMC1/16 390JATP	J24185390		1	A	B1
R 2040	CHIP RES.	150	1/16W	5%	RMC1/16 151JATP	J24185151		2-	A	B1
R 2041	CHIP RES.	39	1/16W	5%	RMC1/16 390JATP	J24185390		1	A	B2
R 2041	CHIP RES.	150	1/16W	5%	RMC1/16 151JATP	J24185151		2-	A	B2
R 2043	CHIP RES.	22	1/16W	5%	RMC1/16 220JATP	J24185220		1	A	B1
R 2043	CHIP RES.	10	1/16W	5%	RMC1/16 100JATP	J24185100		2-	A	B1
R 2044	CHIP RES.	22	1/16W	5%	RMC1/16 220JATP	J24185220		1	A	B1
R 2044	CHIP RES.	10	1/16W	5%	RMC1/16 100JATP	J24185100		2-	A	B1
R 2045	CHIP RES.	22	1/16W	5%	RMC1/16 220JATP	J24185220		1	A	B2
R 2045	CHIP RES.	10	1/16W	5%	RMC1/16 100JATP	J24185100		2-	A	B2
R 2047	CHIP RES.	56	1/16W	5%	RMC1/16 560JATP	J24185560		1	B	e2
R 2048	CHIP RES.	1k	1/16W	5%	RMC1/16 102JATP	J24185102		1-	B	g3
R 2049	CHIP RES.	22	1/16W	5%	RMC1/16 220JATP	J24185220		1-	B	f2
R 2050	CHIP RES.	1k	1/16W	5%	RMC1/16 102JATP	J24185102		1-	B	g3
R 2051	CHIP RES.	1k	1/16W	5%	RMC1/16 102JATP	J24185102		1-	B	g3
R 2052	CHIP RES.	47	1/16W	5%	RMC1/16 470JATP	J24185470		1-	B	f2
R 2053	CHIP RES.	68	1/16W	5%	RMC1/16 680JATP	J24185680		1-	B	f2
R 2054	CHIP RES.	1k	1/16W	5%	RMC1/16 102JATP	J24185102		1-	B	g3
R 2056	CHIP RES.	1k	1/16W	5%	RMC1/16 102JATP	J24185102		1	A	B1
R 2056	CHIP RES.	390	1/16W	5%	RMC1/16 391JATP	J24185391		2-	A	B1

Local Unit

REF.	DESCRIPTION	VALUE	V/W	TOL.	MFR'S DESIG	VXSTD P/N	VERS.	LOT.	SIDE	LAY ADR
R 2057	CHIP RES.	180	1/10W	5%	RMC1/10T 181J	J24205181		1-	B	f2
R 2058	CHIP RES.	10k	1/16W	1%	RMC1/16 103FTP	J24183103		1-	A	F1
R 2059	CHIP RES.	10k	1/16W	1%	RMC1/16 103FTP	J24183103		1-	A	F1
R 2060	CHIP RES.	10k	1/16W	1%	RMC1/16 103FTP	J24183103		1-	A	F1
R 2061	CHIP RES.	10k	1/16W	1%	RMC1/16 103FTP	J24183103		1-	A	F1
R 2062	CHIP RES.	10k	1/16W	1%	RMC1/16 103FTP	J24183103		1-	A	F1
R 2063	CHIP RES.	10k	1/16W	1%	RMC1/16 103FTP	J24183103		1-	A	F1
R 2064	CHIP RES.	10k	1/16W	1%	RMC1/16 103FTP	J24183103		1-	A	F1
R 2065	CHIP RES.	10k	1/16W	1%	RMC1/16 103FTP	J24183103		1-	A	F1
R 2066	CHIP RES.	10k	1/16W	1%	RMC1/16 103FTP	J24183103		1-	A	E1
R 2067	CHIP RES.	10k	1/16W	1%	RMC1/16 103FTP	J24183103		1	A	E1
R 2067	CHIP RES.	0	1/16W	5%	RMC1/16 000JATP	J24185000		2-	A	E1
R 2068	CHIP RES.	20k	1/16W	1%	RMC1/16 203FTP	J24183203		1-	A	F2
R 2069	CHIP RES.	20k	1/16W	1%	RMC1/16 203FTP	J24183203		1-	A	F2
R 2070	CHIP RES.	20k	1/16W	1%	RMC1/16 203FTP	J24183203		1-	A	F2
R 2071	CHIP RES.	20k	1/16W	1%	RMC1/16 203FTP	J24183203		1-	A	F2
R 2072	CHIP RES.	20k	1/16W	1%	RMC1/16 203FTP	J24183203		1-	A	F2
R 2073	CHIP RES.	20k	1/16W	1%	RMC1/16 203FTP	J24183203		1-	A	F2
R 2074	CHIP RES.	20k	1/16W	1%	RMC1/16 203FTP	J24183203		1	A	F2
R 2074	CHIP RES.	20k	1/16W	1%	RMC1/16 203FTP	J24183203		2-	A	F2
R 2075	CHIP RES.	20k	1/16W	1%	RMC1/16 203FTP	J24183203		1-	A	F2
R 2076	CHIP RES.	20k	1/16W	1%	RMC1/16 203FTP	J24183203		1-	A	F2
R 2077	CHIP RES.	20k	1/16W	1%	RMC1/16 203FTP	J24183203		1-	A	E2
R 2078	CHIP RES.	20k	1/16W	1%	RMC1/16 203FTP	J24183203		1-	A	E2
R 2079	CHIP RES.	100k	1/16W	5%	RMC1/16 104JATP	J24185104		1-	A	F1
R 2080	CHIP RES.	1k	1/10W	5%	RMC1/10T 102J	J24205102		1		
R 2081	CHIP RES.	22k	1/16W	5%	RMC1/16 223JATP	J24185223		1-	A	F2
R 2082	CHIP RES.	22k	1/16W	5%	RMC1/16 223JATP	J24185223		1-	A	F2
R 2083	CHIP RES.	1k	1/16W	5%	RMC1/16 102JATP	J24185102		1	A	A2
R 2083	CHIP RES.	10k	1/16W	5%	RMC1/16 103JATP	J24185103		2-	A	A2
R 2084	CHIP RES.	1k	1/16W	5%	RMC1/16 102JATP	J24185102		1	B	f1
R 2084	CHIP RES.	2.2k	1/16W	5%	RMC1/16 222JATP	J24185222		2-	B	f1
R 2085	CHIP RES.	100	1/16W	5%	RMC1/16 101JATP	J24185101		1-	A	F1
R 2086	CHIP RES.	15	1/16W	5%	RMC1/16 150JATP	J24185150		1		
R 2087	CHIP RES.	39	1/16W	5%	RMC1/16 390JATP	J24185390		1-	B	b1
R 2088	CHIP RES.	100	1/16W	5%	RMC1/16 101JATP	J24185101		1-	A	G1
R 2089	CHIP RES.	68	1/16W	5%	RMC1/16 680JATP	J24185680		1	B	g2
R 2089	CHIP RES.	390	1/16W	5%	RMC1/16 391JATP	J24185391		2-	B	g2
R 2090	CHIP RES.	15	1/16W	5%	RMC1/16 150JATP	J24185150		1		
R 2091	CHIP RES.	3.9k	1/16W	5%	RMC1/16 392JATP	J24185392		1-	A	H1
R 2092	CHIP RES.	1k	1/16W	5%	RMC1/16 102JATP	J24185102		1-	A	G1
R 2093	CHIP RES.	1k	1/16W	5%	RMC1/16 102JATP	J24185102		1-	A	G1
R 2095	CHIP RES.	180	1/10W	5%	RMC1/10T 181J	J24205181		1-	B	g2
R 2096	CHIP RES.	1k	1/16W	5%	RMC1/16 102JATP	J24185102		1-	B	g1
R 2097	CHIP RES.	56	1/16W	5%	RMC1/16 560JATP	J24185560		1-	A	G1
R 2098	CARBON FILM RES.	100	1/6W	5%	RD16TPJ101 100	J07225101		1	A	G1
R 2098	CHIP RES.	100	1/16W	5%	RMC1/16 101JATP	J24185101		2-	A	G1
R 2099	CHIP RES.	1k	1/16W	5%	RMC1/16 102JATP	J24185102		1-	B	g1
R 2100	CHIP RES.	1k	1/16W	5%	RMC1/16 102JATP	J24185102		1-	B	g1
R 2104	CHIP RES.	1k	1/16W	5%	RMC1/16 102JATP	J24185102		1-	A	E2
R 2105	CHIP RES.	100k	1/16W	5%	RMC1/16 104JATP	J24185104		1-	A	E2
R 2111	CHIP RES.	10k	1/16W	5%	RMC1/16 103JATP	J24185103		1-	A	F1
R 2112	CHIP RES.	10k	1/16W	5%	RMC1/16 103JATP	J24185103		1-	A	G1
R 2113	CHIP RES.	1k	1/16W	5%	RMC1/16 102JATP	J24185102		1-	A	H1
R 2114	CHIP RES.	33k	1/16W	5%	RMC1/16 333JATP	J24185333		1	A	E1
R 2114	CHIP RES.	4.7k	1/16W	5%	RMC1/16 472JATP	J24185472		2-	A	E1
R 2115	CHIP RES.	270k	1/16W	5%	RMC1/16 274JATP	J24185274		1-	A	H1
R 2116	CHIP RES.	470	1/16W	5%	RMC1/16 471JATP	J24185471		1-	A	F1
R 2117	CHIP RES.	10k	1/16W	5%	RMC1/16 103JATP	J24185103		1-	A	E1
R 2118	CHIP RES.	470	1/16W	5%	RMC1/16 471JATP	J24185471		1-	A	F1
R 2119	CHIP RES.	100	1/16W	5%	RMC1/16 101JATP	J24185101		1-	A	F1
R 2120	CHIP RES.	100	1/16W	5%	RMC1/16 101JATP	J24185101		1-	B	c1
R 2121	CHIP RES.	1k	1/16W	5%	RMC1/16 102JATP	J24185102		1-	B	g2
R 2123	CHIP RES.	47	1/16W	5%	RMC1/16 470JATP	J24185470		1		
R 2124	CHIP RES.	0	1/16W	5%	RMC1/16 000JATP	J24185000		1-	B	f2
R 2126	CHIP RES.	220	1/16W	5%	RMC1/16 221JATP	J24185221		1-	B	e2
R 2127	CHIP RES.	22	1/16W	5%	RMC1/16 220JATP	J24185220		1		
R 2128	CHIP RES.	220	1/16W	5%	RMC1/16 221JATP	J24185221		1-	A	E2

Local Unit

REF.	DESCRIPTION	VALUE	V/W	TOL.	MFR'S DESIG	VXSTD P/N	VERS.	LOT.	SIDE	LAY ADR
R 2129	CHIP RES.	100k	1/16W	5%	RMC1/16 104JATP	J24185104		1-	A	E2
R 2130	CHIP RES.	1k	1/16W	5%	RMC1/16 102JATP	J24185102		1-	A	E2
R 2131	CHIP RES.	100k	1/16W	5%	RMC1/16 104JATP	J24185104		1-	A	E2
R 2132	CHIP RES.	470	1/16W	5%	RMC1/16 471JATP	J24185471		1-	A	E1
R 2133	CHIP RES.	1k	1/16W	5%	RMC1/16 102JATP	J24185102		1		
R 2134	CHIP RES.	100k	1/16W	5%	RMC1/16 104JATP	J24185104		1		
R 2135	CHIP RES.	56	1/16W	5%	RMC1/16 560JATP	J24185560		1	B	a2
R 2135	CHIP RES.	180	1/16W	5%	RMC1/16 181JATP	J24185181		2-	B	a2
R 2136	CHIP RES.	180	1/10W	5%	RMC1/10T 181J	J24205181		1	B	h2
R 2136	CHIP RES.	120	1/10W	5%	RMC1/10T 121J	J24205121		2-	B	h2
R 2137	CHIP RES.	180	1/10W	5%	RMC1/10T 181J	J24205181		1	B	h2
R 2137	CHIP RES.	150	1/10W	5%	RMC1/10T 151J	J24205151		2-	B	h2
R 2138	CHIP RES.	100	1/16W	5%	RMC1/16 101JATP	J24185101		1-	B	b1
R 2139	CHIP RES.	100	1/16W	5%	RMC1/16 101JATP	J24185101		1-	B	c1
R 2140	CHIP RES.	100	1/16W	5%	RMC1/16 101JATP	J24185101		1-	B	b1
R 2141	CHIP RES.	10k	1/16W	5%	RMC1/16 103JATP	J24185103		1-	B	b1
R 2142	CHIP RES.	22k	1/16W	5%	RMC1/16 223JATP	J24185223		1-	B	b1
R 2143	CHIP RES.	100k	1/16W	5%	RMC1/16 104JATP	J24185104		1-	B	c1
R 2144	CHIP RES.	470	1/16W	5%	RMC1/16 471JATP	J24185471		1	B	c1
R 2144	CHIP RES.	100	1/16W	5%	RMC1/16 101JATP	J24185101		2-	B	c1
R 2145	CHIP RES.	220	1/16W	5%	RMC1/16 221JATP	J24185221		1-	A	C3
R 2146	CHIP RES.	220	1/16W	5%	RMC1/16 221JATP	J24185221		1-	A	C3
R 2147	CHIP RES.	220	1/16W	5%	RMC1/16 221JATP	J24185221		1-	A	C3
R 2148	CHIP RES.	220	1/16W	5%	RMC1/16 221JATP	J24185221		1-	B	c2
R 2149	CHIP RES.	220	1/16W	5%	RMC1/16 221JATP	J24185221		1-	B	c2
R 2150	CHIP RES.	220	1/16W	5%	RMC1/16 221JATP	J24185221		1-	B	c2
R 2151	CHIP RES.	220	1/16W	5%	RMC1/16 221JATP	J24185221		1-	B	a2
R 2152	CHIP RES.	220	1/16W	5%	RMC1/16 221JATP	J24185221		1-	B	a2
R 2153	CHIP RES.	220	1/16W	5%	RMC1/16 221JATP	J24185221		1-	B	a2
R 2154	CHIP RES.	100k	1/16W	5%	RMC1/16 104JATP	J24185104		1-	A	C3
R 2155	CHIP RES.	1k	1/16W	5%	RMC1/16 102JATP	J24185102		1-	B	g2
R 2156	CHIP RES.	1k	1/16W	5%	RMC1/16 102JATP	J24185102		1-	A	A2
R 2157	CHIP RES.	0	1/16W	5%	RMC1/16 000JATP	J24185000		1-	B	g1
R 2158	CARBON FILM RES.	4.7k	1/6W	5%	RD16TPJ472 4.7K	J07225472		1	B	f1
R 2158	CHIP RES.	6.8k	1/16W	5%	RMC1/16 682JATP	J24185682		2-	B	f1
R 2159	CHIP RES.	0	1/16W	5%	RMC1/16 000JATP	J24185000		1-	A	H2
R 2160	CHIP RES.	1k	1/10W	5%	RMC1/10T 102J	J24205102		2-	B	d2
R 2161	CHIP RES.	100k	1/16W	5%	RMC1/16 104JATP	J24185104		2-	B	e2
R 2164	CHIP RES.	180	1/16W	5%	RMC1/16 181JATP	J24185181		2-	A	H2
R 2165	CHIP RES.	0	1/16W	5%	RMC1/16 000JATP	J24185000		2-	A	G2
R 2166	CHIP RES.	1k	1/16W	5%	RMC1/16 102JATP	J24185102		2-	A	B2
R 2167	CHIP RES.	100	1/16W	5%	RMC1/16 101JATP	J24185101		2-	A	E1
R 2168	CHIP RES.	0	1/10W	5%	RMC1/10T 000J	J24205000		2-	B	c2
R 2169	CHIP RES.	0	1/16W	5%	RMC1/16 000JATP	J24185000		2-	B	b1
R 2170	CHIP RES.	0	1/16W	5%	RMC1/16 000JATP	J24185000		2-	B	c1
T 2001	COIL 05RF				R12-S971B	L0022494		1-	A	F1
T 2002	COIL 05RF				R12-S971B	L0022494		1-	A	G1
T 2003	COIL 05RF				R12-S973Y	L0022496		1	A	E1
T 2003	COIL 05RF				R12-S975Y	L0022498		2-	A	E1
T 2004	COIL 05RF				R12-S973Y	L0022496		1	A	F1
T 2004	COIL 05RF				R12-S975Y	L0022498		2-	A	F1
TC2001	TRIMMER CAP.	6pF			ECR-JA006A11X	K91000251		1-	A	D1
TC2002	TRIMMER CAP.	6pF			ECR-JA006A11X	K91000251		1-	A	D1
TC2003	TRIMMER CAP.	6pF			ECR-JA006A11X	K91000251		1-	A	C1
TC2004	TRIMMER CAP.	6pF			ECR-JA006A11X	K91000251		1-	A	D2
TC2005	TRIMMER CAP.	6pF			ECR-JA006A11X	K91000251		1-	A	D2
TC2006	TRIMMER CAP.	6pF			ECR-JA006A11X	K91000251		1-	A	C2
TP2001	TERMINAL				TP-K IPS-1136	Q5000050		1-	A	D2
	SHIELD CASE				(A)	RA0073900		1-		
	SHIELD CASE COVER				(B)	RA0074000		1-		
	SHIELD CASE				(B)	RA0074100		1-		
	SHIELD CASE				(C)	RA0074200		1-		
	LEAF SPRING					R0125800		2-		
	LEAF SPRING					R0125800		2-		
	LEAF SPRING					R0125800		2-		
	LEAF SPRING					R0140031	W/ CE LABEL	3-		

Local Unit

Note:

REF Unit Parts List

REF.	DESCRIPTION	VALUE	V/W	TOL.	MFR'S DESIG	VXSTD P/N	VERS.	LOT.	SIDE	LAY ADR
*** REF UNIT ***										
PCB with Components						CB0405001				
Printed Circuit Board						FR001650B		1-		
C 2801	CHIP CAP.	0.01uF	25V	B	GRM39B103K25PT	K22144803		1-	A	
C 2802	CHIP TA.CAP.	10uF	16V		TESVC1C106M12R	K78120011		1-	A	
C 2803	CHIP CAP.	0.01uF	25V	B	GRM39B103K25PT	K22144803		1-	A	
C 2804	CHIP CAP.	5pF	50V	CH	GRM39CH050C50PT	K22174206		1	A	
C 2804	CHIP CAP.	10pF	50V	CH	GRM39CH100C50PT	K22174248		2-	A	
C 2805	CHIP CAP.	0.01uF	25V	B	GRM39B103K25PT	K22144803		1-	A	
C 2806	CHIP CAP.	100pF	50V	CH	GRM39CH101J50PT	K22174235		1-	A	
C 2806	CHIP CAP.	82pF	50V	CH	GRM39CH820J50PT	K22174233		20-	A	
C 2807	CHIP CAP.	22pF	50V	CH	GRM39CH220J50PT	K22174219		1-	A	
C 2808	CHIP CAP.	27pF	50V	UJ	GRM39UJ270J50PT	K22174318		1	A	
C 2808	CHIP CAP.	22pF	50V	UJ	GRM39UJ220J50PT	K22174316		2-	A	
J 2801	CONNECTOR				5124-04BHPB	P1090426		1-	A	
Q 2801	TRANSISTOR				2SC2714YTE85R	G3327147Y		1-	A	
Q 2802	TRANSISTOR				2SC2714YTE85R	G3327147Y		1-	A	
R 2801	CHIP RES.	100	1/16W	5%	RMC1/16 101JATP	J24185101		1-	A	
R 2802	CHIP RES.	470	1/16W	5%	RMC1/16 471JATP	J24185471		1-	A	
R 2803	CHIP RES.	100k	1/16W	5%	RMC1/16 104JATP	J24185104		1-	A	
R 2804	CHIP RES.	3.3k	1/16W	5%	RMC1/16 332JATP	J24185332		1	A	
R 2804	CHIP RES.	1.8k	1/16W	5%	RMC1/16 182JATP	J24185182		2-	A	
R 2805	CHIP RES.	330	1/16W	5%	RMC1/16 331JATP	J24185331		1-	A	
R 2806	CHIP RES.	22k	1/16W	5%	RMC1/16 223JATP	J24185223		1-	A	
R 2807	CHIP RES.	10k	1/16W	5%	RMC1/16 103JATP	J24185103		1-	A	
TC2801	TRIMMER CAP.	10pF			ECR-JA010A11X	K91000227		1-	A	
TC2801	TRIMMER CAP.	20pF			ECR-JA020E11X	K91000228		20-	A	
X 2801	XTAL TOP-B	20.97152MHz			20.97152MHZ	H0103167		1	A	
X 2801	XTAL TOP-B	19.09333MHz			19.09333MHZ	H0103211		2-	A	

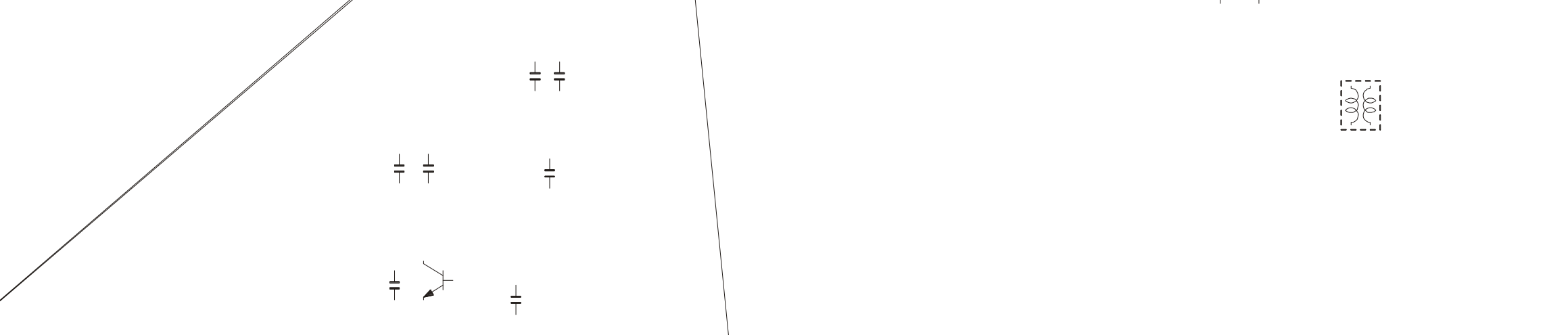
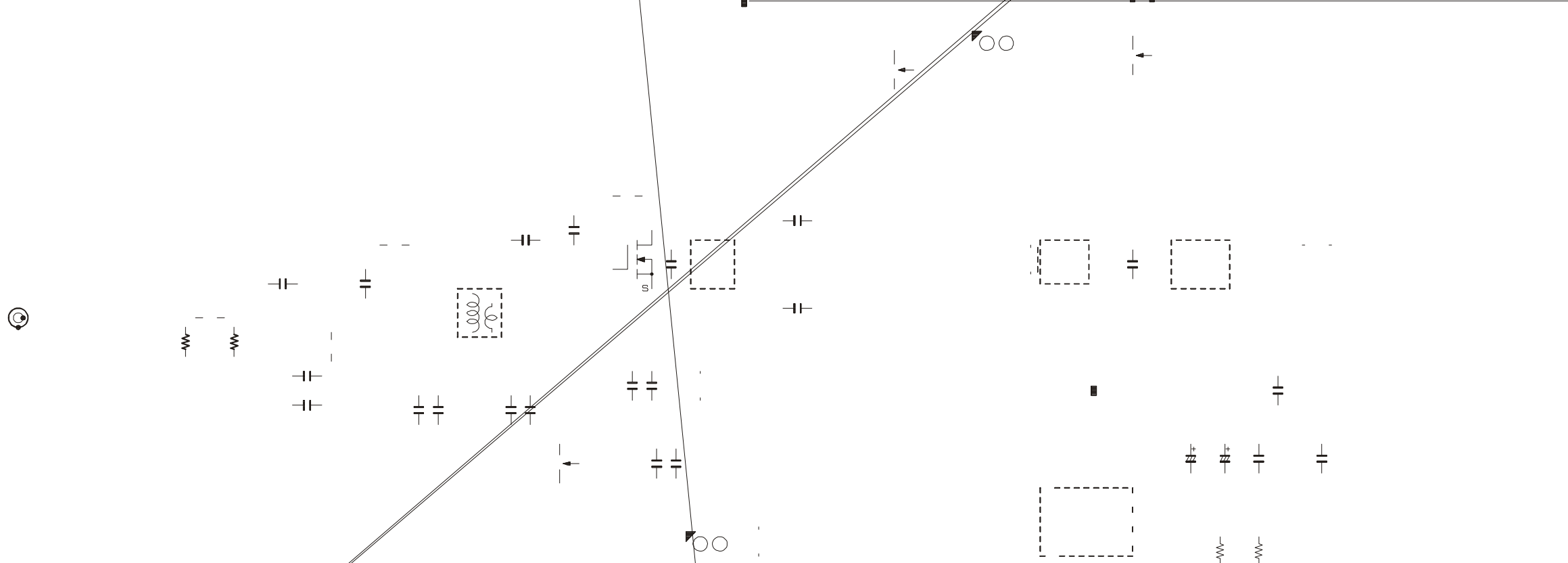
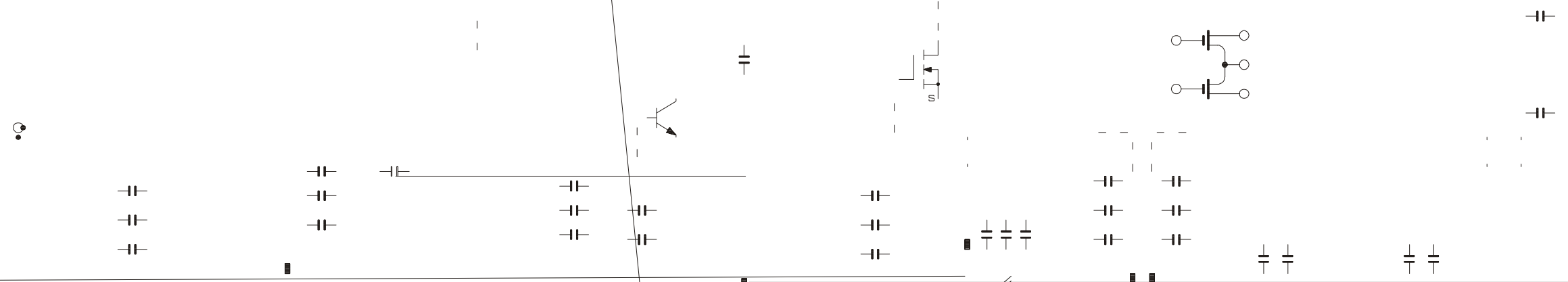

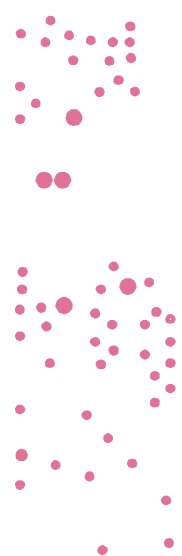

PA Unit

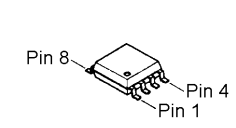
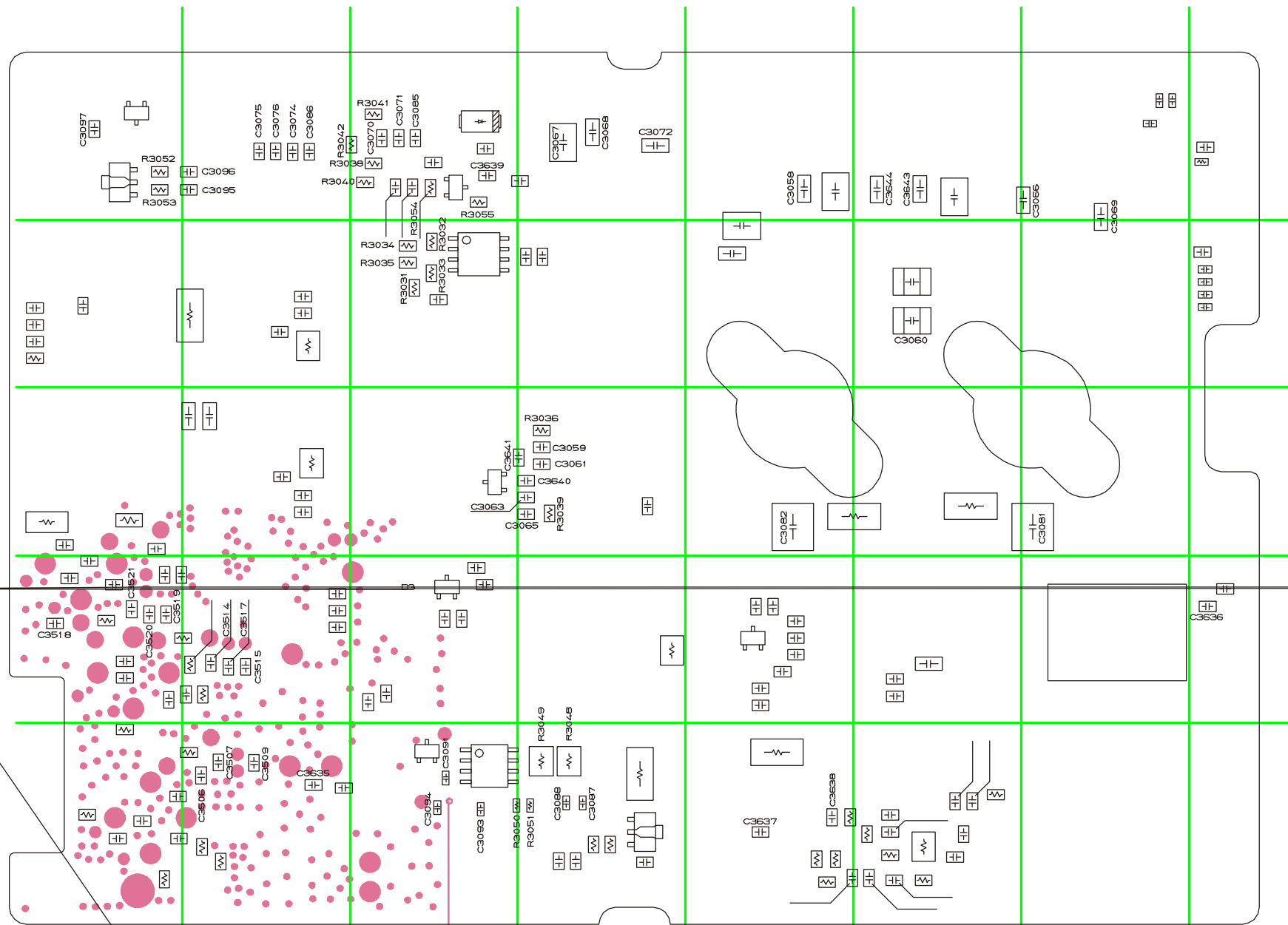

***A^P* Lot**

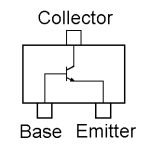
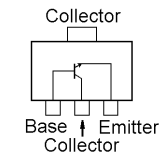

***L* Lot**

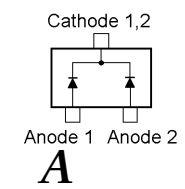

Parts List

REF.	DESCRIPTION	VALUE	V/W	TOL.	MFR'S DESIG	VXSTD P/N	VERS.	LOT.	SIDE	LAY ADR
*** PA-UNIT ***										
PCB with Components						CS1619001				
Printed Circuit Board						FR001670C 2-				
C 3001	AL.ELECTRO.CAP.	10uF	16V		ECEV1CS100SR	K48120001		1-	A	C4
C 3002	CHIP CAP.	0.1uF	25V	B	GRM40B104M25PT	K22140811		1-	B	f5
C 3003	CHIP CAP.	0.01uF	50V	B	GRM40B103K50PT	K22170826		1-	B	e4
C 3004	CHIP CAP.	0.1uF	25V	B	GRM40B104M25PT	K22140811		1-	B	f5
C 3005	CHIP CAP.	0.01uF	50V	B	GRM40B103K50PT	K22170826		1-	B	f5
C 3006	CHIP CAP.	0.001uF	50V	B	GRM40B102M50PT	K22170805		1-	B	f5
C 3007	CHIP CAP.	0.001uF	50V	B	GRM40B102M50PT	K22170805		1-	B	e4
C 3008	CHIP CAP.	0.01uF	50V	B	GRM40B103K50PT	K22170826		1-	B	f5
C 3009	AL.ELECTRO.CAP.	22uF	16V		ECEV1CA220SR	K48120002		1-	A	C5
C 3010	CHIP CAP.	0.047uF	50V	B	GRM40B473M50PT	K22170823		1-	B	d5
C 3011	CHIP CAP.	0.1uF	25V	B	GRM40B104M25PT	K22140811		1-	B	f5
C 3012	CHIP CAP.	0.001uF	50V	B	GRM40B102M50PT	K22170805		1-	B	f5
C 3013	AL.ELECTRO.CAP.	22uF	16V		ECEV1CA220SR	K48120002		1		
C 3014	CHIP CAP.	0.001uF	50V	B	GRM40B102M50PT	K22170805		1-	B	e4
C 3015	CHIP CAP.	0.01uF	50V	B	GRM40B103K50PT	K22170826		1-	B	e4
C 3016	CHIP CAP.	0.1uF	25V	B	GRM40B104M25PT	K22140811		1-	A	B5
C 3017	CHIP CAP.	0.1uF	25V	B	GRM40B104M25PT	K22140811		1-	B	f5
C 3018	CHIP CAP.	0.01uF	50V	B	GRM40B103K50PT	K22170826		1-	B	e4
C 3019	CHIP CAP.	0.001uF	50V	B	GRM40B102M50PT	K22170805		1-	B	e4
C 3020	CHIP CAP.	0.01uF	50V	B	GRM40B103K50PT	K22170826		1-	B	d5
C 3021	CHIP CAP.	0.001uF	50V	B	GRM40B102M50PT	K22170805		1-	B	f5
C 3022	CHIP CAP.	0.01uF	50V	B	GRM40B103K50PT	K22170826		1-	A	B5
C 3023	AL.ELECTRO.CAP.	10uF	16V		ECEV1CS100SR	K48120001		1-	A	C4
C 3024	CHIP CAP.	0.001uF	50V	B	GRM40B102M50PT	K22170805		1-	B	d5
C 3025	CHIP CAP.	0.01uF	50V	B	GRM40B103K50PT	K22170826		1-	A	A5
C 3026	AL.ELECTRO.CAP.	22uF	16V		ECEV1CA220SR	K48120002		1-	A	C5
C 3027	AL.ELECTRO.CAP.	10uF	16V		ECEV1CS100SR	K48120001		1-	A	A4
C 3028	CHIP CAP.	0.1uF	25V	B	GRM40B104M25PT	K22140811		1-	B	f4
C 3029	CHIP CAP.	0.01uF	50V	B	GRM40B103K50PT	K22170826		1-	B	h4
C 3030	CHIP CAP.	0.001uF	50V	B	GRM40B102M50PT	K22170805		1-	B	f4
C 3031	CHIP CAP.	0.1uF	25V	B	GRM40B104M25PT	K22140811		1-	B	e4
C 3032	CHIP CAP.	0.001uF	50V	B	GRM40B102M50PT	K22170805		1-	B	e4
C 3036	CHIP CAP.	0.01uF	50V	B	GRM40B103K50PT	K22170826		1-	A	A4
C 3037	CHIP CAP.	390pF	200V	CH	GRM42-6CH391J200PT	K22231202		1-	B	f4
C 3038	AL.ELECTRO.CAP.	10uF	16V		ECEV1CS100SR	K48120001		1-	A	A4
C 3043	CERAMIC CAP.	0.0068uF	200V	SL	GRM44-1SL682J200PT	K22236101		1-	A	B3
C 3044	CERAMIC CAP.	0.0068uF	200V	SL	GRM44-1SL682J200PT	K22236101		1-	A	C3
C 3045	CHIP CAP.	0.01uF	50V	B	GRM40B103K50PT	K22170826		1-	B	c1
C 3046	CHIP CAP.	0.047uF	50V	B	GRM40B473M50PT	K22170823		1-	B	c1
C 3047	CHIP CAP.	0.001uF	50V	B	GRM40B102M50PT	K22170805		1-	B	c1
C 3048	CHIP CAP.	0.01uF	50V	B	GRM40B103K50PT	K22170826		1-	B	c2
C 3049	CHIP CAP.	100pF	500V	CH	GRM42-6CH101J500PT	K22271237		1-	A	B2
C 3050	CHIP CAP.	100pF	500V	CH	GRM42-6CH101J500PT	K22271237		1-	A	D2
C 3053	CHIP CAP.	0.01uF	50V	B	GRM40B103K50PT	K22170826		1-	B	d2
C 3054	CHIP CAP.	0.01uF	50V	B	GRM40B103K50PT	K22170826		1-	B	c1
C 3055	CHIP CAP.	0.1uF	200V	X7R	GRM43-2X7R104K200PT	K22237801		1-	B	e1
C 3056	CHIP CAP.	0.001uF	50V	B	GRM40B102M50PT	K22170805		1-	B	d2
C 3057	FILM CAP.	470pF	500V		UC342H4700J-T	K33279015		1-	B	f2
C 3058	CHIP CAP.	0.001uF	500V	W5R	GRM42-6W5R102K500PT	K22271801		1-	B	e1
C 3059	CHIP CAP.	0.1uF	25V	B	GRM40B104M25PT	K22140811		1-	B	d3
C 3060	FILM CAP.	470pF	500V		UC342H4700J-T	K33279015		1-	B	f2
C 3061	CHIP CAP.	0.01uF	50V	B	GRM40B103K50PT	K22170826		1-	B	d3
C 3062	AL.ELECTRO.CAP.	470uF	25V		RJ3-25V471MAX 470UF	K40149042		1-	A	D1
C 3063	CHIP CAP.	0.1uF	25V	B	GRM40B104M25PT	K22140811		1-	B	d3
C 3064	AL.ELECTRO.CAP.	470uF	25V		RJ3-25V471MAX 470UF	K40149042		1-	A	D1
C 3065	CHIP CAP.	0.01uF	50V	B	GRM40B103K50PT	K22170826		1-	B	d3
C 3066	CHIP CAP.	39pF	500V	CH	GRM42-6CH390J500PT	K22271227		1-	B	g1
C 3066	CHIP CAP.	27pF	500V	CH	GRM42-6CH270J500PT	K22271223		3-	B	g1
C 3067	CHIP CAP.	0.1uF	200V	X7R	GRM43-2X7R104K200PT	K22237801		1-	B	d1
C 3068	CHIP CAP.	0.01uF	200V	X7R	GRM42-6X7R103K200PT	K22231802		1-	B	d1
C 3069	CHIP CAP.	27pF	500V	CH	GRM42-6CH270J500PT	K22271223		1-	B	g1
C 3070	CHIP CAP.	0.001uF	50V	B	GRM40B102M50PT	K22170805		1-	B	c1
C 3071	CHIP CAP.	0.047uF	50V	B	GRM40B473M50PT	K22170823		1-	B	c1
C 3072	CHIP CAP.	0.001uF	200V	SL	GRM42-6SL102J200PT	K22231104		1-	B	d1
C 3073	CERAMIC CAP.	100pF	500V	SL	DD06-979SL101K500	K26270037		1-		

PA Unit

REF.	DESCRIPTION	VALUE	V/W	TOL.	MFR'S DESIG	VXSTD P/N	VERS.	LOT.	SIDE	LAY ADR
C 3074	CHIP CAP.	0.1uF	25V	B	GRM40B104M25PT	K22140811		1-	B	b1
C 3075	CHIP CAP.	0.01uF	50V	B	GRM40B103K50PT	K22170826		1-	B	b1
C 3076	CHIP CAP.	0.001uF	50V	B	GRM40B102M50PT	K22170805		1-	B	b1
C 3077	CHIP CAP.	0.1uF	25V	B	GRM40B104M25PT	K22140811		1-	A	A3
C 3078	CHIP CAP.	0.001uF	50V	B	GRM40B102M50PT	K22170805		1-	A	A3
C 3079	CHIP CAP.	0.1uF	25V	B	GRM40B104M25PT	K22140811		1-	A	D3
C 3080	CHIP CAP.	0.001uF	50V	B	GRM40B102M50PT	K22170805		1-	A	D3
C 3081	CERAMIC CAP.	0.0068uF	200V	SL	GRM44-1SL682J200PT	K22236101		1-	B	g3
C 3082	CERAMIC CAP.	0.0068uF	200V	SL	GRM44-1SL682J200PT	K22236101		1-	B	e3
C 3085	CHIP CAP.	100pF	50V	CH	GRM40CH101J50PT	K22170235		1-	B	c1
C 3086	CHIP CAP.	100pF	50V	CH	GRM40CH101J50PT	K22170235		1-	B	b1
C 3087	CHIP CAP.	0.1uF	16V	B	GRM39B104K16PT	K22124805		1-	B	d5
C 3088	CHIP CAP.	0.01uF	25V	B	GRM39B103K25PT	K22144803		1-	B	d5
C 3089	AL.ELECTRO.CAP.	47uF	16V		RE2-16V470M 47UF	K40129054		1-	A	E5
C 3090	AL.ELECTRO.CAP.	1uF	50V		RE2-50V010M 1UF	K40179055		1-	A	E5
C 3091	CHIP CAP.	180pF	50V	CH	GRM39CH181J50PT	K22174241		1-	B	c5
C 3092	AL.ELECTRO.CAP.	47uF	16V		RE2-16V470M 47UF	K40129054		1-	A	E5
C 3093	CHIP CAP.	0.01uF	25V	B	GRM39B103K25PT	K22144803		1-	B	c5
C 3094	CHIP CAP.	0.1uF	16V	B	GRM39B104K16PT	K22124805		1-	B	c5
C 3095	CHIP CAP.	0.001uF	50V	B	GRM40B102M50PT	K22170805		1-	B	b1
C 3096	CHIP CAP.	0.01uF	50V	B	GRM40B103K50PT	K22170826		1-	B	b1
C 3097	CHIP CAP.	0.001uF	50V	B	GRM40B102M50PT	K22170805		1-	B	a1
C 3098	CHIP CAP.	0.001uF	50V	B	GRM40B102M50PT	K22170805		1-	A	G1
C 3099	AL.ELECTRO.CAP.	1000uF	16V		RE3-16V102MS 1000UF	K40129067		2-	A	F5
C 3099	AL.ELECTRO.CAP.	1000uF	16V		RE3-16V102MH3 1000UF	K40129096		28-	A	F5
C 3100	CHIP TA.CAP.	0.47uF	25V		TESVA1E474M1-8R	K78140009		4-		
C 3501	CHIP CAP.	0.001uF	50V	B	GRM40B102M50PT	K22170805		1-	A	G5
C 3502	CHIP CAP.	0.001uF	50V	B	GRM40B102M50PT	K22170805		1-	A	G5
C 3503	CHIP CAP.	0.1uF	25V	B	GRM40B104M25PT	K22140811		1-	A	G5
C 3504	CHIP CAP.	0.01uF	50V	B	GRM40B103K50PT	K22170826		1-	A	G5
C 3505	CHIP CAP.	0.001uF	50V	B	GRM40B102M50PT	K22170805		1-	A	G5
C 3506	CHIP CAP.	0.001uF	50V	B	GRM40B102M50PT	K22170805		1-	B	b5
C 3507	CHIP CAP.	0.01uF	50V	B	GRM40B103K50PT	K22170826		1-	B	b5
C 3508	CHIP CAP.	0.001uF	50V	B	GRM40B102M50PT	K22170805		1	A	G4
C 3508	CHIP CAP.	27pF	50V	CH	GRM40CH270J50PT	K22170221		2-	A	G4
C 3509	CHIP CAP.	0.1uF	25V	B	GRM40B104M25PT	K22140811		1-	B	b5
C 3510	CHIP CAP.	0.001uF	50V	B	GRM40B102M50PT	K22170805		1-	A	H4
C 3511	CHIP CAP.	0.1uF	25V	B	GRM40B104M25PT	K22140811		1-	A	G4
C 3512	CHIP CAP.	0.01uF	50V	B	GRM40B103K50PT	K22170826		1-	A	G4
C 3513	CHIP CAP.	0.001uF	50V	B	GRM40B102M50PT	K22170805		1-	A	G4
C 3514	CHIP CAP.	0.001uF	50V	B	GRM40B102M50PT	K22170805		1-	B	b4
C 3515	CHIP CAP.	0.01uF	50V	B	GRM40B103K50PT	K22170826		1-	B	b4
C 3516	CHIP CAP.	0.001uF	50V	B	GRM40B102M50PT	K22170805		1-	A	G4
C 3517	CHIP CAP.	0.1uF	25V	B	GRM40B104M25PT	K22140811		1-	B	b4
C 3518	CHIP CAP.	0.001uF	50V	B	GRM40B102M50PT	K22170805		1-	B	a4
C 3519	CHIP CAP.	0.1uF	25V	B	GRM40B104M25PT	K22140811		1-	B	a4
C 3520	CHIP CAP.	0.01uF	50V	B	GRM40B103K50PT	K22170826		1-	B	a4
C 3521	CHIP CAP.	0.001uF	50V	B	GRM40B102M50PT	K22170805		1-	B	a4
C 3522	CHIP CAP.	0.001uF	500V	W5R	GRM42-6W5R102K500PT	K22271801		1-	A	H3
C 3523	CHIP CAP.	0.1uF	25V	B	GRM40B104M25PT	K22140811		1-	A	H3
C 3524	CHIP CAP.	0.01uF	50V	B	GRM40B103K50PT	K22170826		1-	A	H3
C 3525	CHIP CAP.	39pF	200V	CH	GRM40CH390J200PT	K22230223		1	A	H2
C 3525	CHIP CAP.	27pF	200V	CH	GRM40CH270J200PT	K22230221		2-	A	H2
C 3526	CHIP CAP.	0.001uF	500V	W5R	GRM42-6W5R102K500PT	K22271801		1-	A	H2
C 3527	CHIP CAP.	0.001uF	50V	B	GRM40B102M50PT	K22170805		1-	B	a2
C 3528	CHIP CAP.	0.1uF	25V	B	GRM40B104M25PT	K22140811		1-	B	a2
C 3529	CHIP CAP.	0.01uF	50V	B	GRM40B103K50PT	K22170826		1-	B	a2
C 3530	CHIP CAP.	0.001uF	50V	B	GRM40B102M50PT	K22170805		1-	B	a2
C 3532	CHIP CAP.	0.001uF	50V	B	GRM40B102M50PT	K22170805		1-	B	b4
C 3533	CHIP CAP.	0.01uF	200V	X7R	GRM42-6X7R103K200PT	K22231802		1-	A	G3
C 3534	CHIP CAP.	0.01uF	50V	B	GRM40B103K50PT	K22170826		1-	B	b4
C 3535	CHIP CAP.	0.001uF	500V	W5R	GRM42-6W5R102K500PT	K22271801		1-	B	b3
C 3536	CHIP CAP.	0.1uF	25V	B	GRM40B104M25PT	K22140811		1-	B	b4
C 3537	CHIP CAP.	0.001uF	500V	W5R	GRM42-6W5R102K500PT	K22271801		1	A	F3
C 3537	CHIP CAP.	150pF	200V	CH	GRM40CH151J200PT	K22230230		2-	A	F3
C 3538	CHIP CAP.	0.001uF	500V	W5R	GRM42-6W5R102K500PT	K22271801		1	A	F2
C 3538	CHIP CAP.	150pF	200V	CH	GRM40CH151J200PT	K22230230		2-	A	F2
C 3539	CHIP CAP.	0.001uF	50V	B	GRM40B102M50PT	K22170805		1-	B	b3

REF.	DESCRIPTION	VALUE	V/W	TOL.	MFR'S DESIG	VXSTD P/N	VERS.	LOT.	SIDE	LAY ADR
C 3540	CHIP CAP.	0.1uF	25V	B	GRM40B104M25PT	K22140811		1-	B	b3
C 3541	CHIP CAP.	0.01uF	50V	B	GRM40B103K50PT	K22170826		1-	B	b3
C 3543	FILM CAP.	33pF	500V		UC232H0330J-T	K33279024		1-	A	F3
C 3545	CHIP CAP.	0.01uF	50V	B	GRM40B103K50PT	K22170826		1-	B	b2
C 3547	CHIP CAP.	0.001uF	50V	B	GRM40B102M50PT	K22170805		1-	B	b2
C 3548	CHIP CAP.	0.1uF	25V	B	GRM40B104M25PT	K22140811		1-	B	b2
C 3549	AL.ELECTRO.CAP.	10uF	16V		ECEV1CS100SR	K48120001		1-	A	E4
C 3550	CHIP CAP.	0.01uF	50V	B	GRM40B103K50PT	K22170826		1-	B	c4
C 3551	CHIP CAP.	0.001uF	50V	B	GRM40B102M50PT	K22170805		1-	B	c4
C 3552	CHIP CAP.	0.01uF	50V	B	GRM40B103K50PT	K22170826		1-	A	E4
C 3553	FILM CAP.	22pF	500V		UC232H0220J-T	K33279021		1-		
C 3554	CHIP CAP.	0.001uF	50V	B	GRM40B102M50PT	K22170805		1-	A	E4
C 3555	FILM CAP.	39pF	500V		UC232H0390J-T	K33279038		1-	A	F3
C 3556	CHIP CAP.	0.001uF	50V	B	GRM40B102M50PT	K22170805		1-	B	c4
C 3557	CHIP CAP.	0.01uF	50V	B	GRM40B103K50PT	K22170826		1-	B	c4
C 3558	AL.ELECTRO.CAP.	10uF	16V		ECEV1CS100SR	K48120001		1-	A	E4
C 3559	FILM CAP.	270pF	500V		UC342H2700J-T	K33279013		1-	A	E3
C 3560	FILM CAP.	270pF	500V		UC342H2700J-T	K33279013		1-	A	E2
C 3561	CHIP CAP.	0.001uF	50V	B	GRM40B102M50PT	K22170805		1-	A	D2
C 3562	CHIP CAP.	0.01uF	50V	B	GRM40B103K50PT	K22170826		1-	A	D2
C 3563	CHIP CAP.	0.001uF	50V	B	GRM40B102M50PT	K22170805		1-	A	D4
C 3564	CHIP CAP.	0.01uF	50V	B	GRM40B103K50PT	K22170826		1-	A	D4
C 3566	AL.ELECTRO.CAP.	10uF	16V		ECEV1CS100SR	K48120001		1-	A	E1
C 3567	AL.ELECTRO.CAP.	10uF	16V		ECEV1CS100SR	K48120001		1-	A	D4
C 3568	CHIP CAP.	0.001uF	50V	B	GRM40B102M50PT	K22170805		1	A	G5
C 3568	CHIP CAP.	27pF	50V	CH	GRM40CH270J50PT	K22170221		2-	A	G5
C 3571	AL.ELECTRO.CAP.	100uF	16V		SMG1CVB101M 100UF	K40129060		1-	A	G5
C 3572	CHIP CAP.	0.01uF	50V	B	GRM40B103K50PT	K22170826		1-	B	b5
C 3573	CHIP CAP.	0.01uF	50V	B	GRM40B103K50PT	K22170826		1-	B	a5
C 3574	CHIP CAP.	0.001uF	50V	B	GRM40B102M50PT	K22170805		1-	B	b5
C 3575	CHIP CAP.	0.001uF	50V	B	GRM40B102M50PT	K22170805		1-	B	a5
C 3576	AL.ELECTRO.CAP.	100uF	16V		SMG1CVB101M 100UF	K40129060		1-	A	F3
C 3577	CHIP CAP.	0.001uF	500V	W5R	GRM42-6W5R102K500PT	K22271801		1-	A	H3
C 3578	CHIP CAP.	0.001uF	50V	B	GRM40B102M50PT	K22170805		1-	B	a3
C 3579	CHIP CAP.	0.001uF	50V	B	GRM40B102M50PT	K22170805		1-	B	a4
C 3580	CHIP CAP.	0.01uF	50V	B	GRM40B103K50PT	K22170826		1-	B	a4
C 3581	CHIP CAP.	0.01uF	50V	B	GRM40B103K50PT	K22170826		1-	B	a4
C 3582	AL.ELECTRO.CAP.	100uF	16V		SMG1CVB101M 100UF	K40129060		1-	A	G4
C 3583	CHIP CAP.	0.01uF	50V	B	GRM40B103K50PT	K22170826		1	B	b4
C 3584	CHIP CAP.	0.01uF	50V	B	GRM40B103K50PT	K22170826		1	B	a4
C 3585	CHIP CAP.	0.001uF	50V	B	GRM40B102M50PT	K22170805		1	B	a4
C 3585	CHIP CAP.	220pF	50V	CH	GRM40CH221J50PT	K22170243		2-	B	a4
C 3586	CHIP CAP.	0.001uF	50V	B	GRM40B102M50PT	K22170805		1	B	a4
C 3586	CHIP CAP.	220pF	50V	CH	GRM40CH221J50PT	K22170243		2-	B	a4
C 3587	CHIP CAP.	0.001uF	50V	B	GRM40B102M50PT	K22170805		1		
C 3588	CHIP CAP.	0.01uF	50V	B	GRM40B103K50PT	K22170826		1		
C 3589	CHIP CAP.	0.001uF	50V	B	GRM40B102M50PT	K22170805		1-	B	b4
C 3590	CHIP CAP.	0.01uF	50V	B	GRM40B103K50PT	K22170826		1-	B	a4
C 3591	CHIP CAP.	0.1uF	25V	B	GRM40B104M25PT	K22140811		1-	B	a3
C 3592	AL.ELECTRO.CAP.	100uF	16V		SMG1CVB101M 100UF	K40129060		1-	A	G4
C 3593	CHIP CAP.	22pF	50V	CH	GRM40CH220J50PT	K22170219		1		
C 3594	CHIP CAP.	0.001uF	50V	B	GRM40B102M50PT	K22170805		1		
C 3595	CHIP CAP.	0.01uF	50V	B	GRM40B103K50PT	K22170826		1		
C 3596	CHIP CAP.	0.001uF	50V	B	GRM40B102M50PT	K22170805		1-	B	c4
C 3597	CHIP CAP.	0.001uF	50V	B	GRM40B102M50PT	K22170805		1-	B	c4
C 3598	CHIP CAP.	0.001uF	50V	B	GRM40B102M50PT	K22170805		1-	B	b5
C 3599	CHIP CAP.	0.001uF	50V	B	GRM40B102M50PT	K22170805		1-	B	d1
C 3600	CHIP CAP.	0.1uF	200V	X7R	GRM43-2X7R104K200PT	K22237801		1-	B	f1
C 3601	FILM CAP.	0.1uF	100V		ECQ-B1104JF	K50205104		1-		
C 3602	CERAMIC CAP.	68pF	500V	SL	DD05-979SL680K500	K26270033		1		
C 3603	CHIP CAP.	0.01uF	200V	X7R	GRM42-6X7R103K200PT	K22231802		2-	B	b3
C 3604	CHIP CAP.	0.001uF	50V	B	GRM40B102M50PT	K22170805		2-	A	G3
C 3605	CHIP CAP.	0.01uF	50V	B	GRM40B103K50PT	K22170826		2-	A	G3
C 3606	FILM CAP.	22pF	500V		UC232H0220J-T	K33279021		2-		
C 3607	FILM CAP.	12pF	500V		UC232H0120J-T	K33279020		2-		
C 3608	CERAMIC CAP.	68pF	500V	SL	DD05-979SL680K500	K26270033		2-		
C 3609	CERAMIC CAP.	56pF	500V	CH	DD08-979CH560J500	K26270130		2-		
C 3610	CHIP CAP.	0.01uF	25V	B	GRM39B103K25PT	K22144803		2-	B	h2

PA Unit

REF.	DESCRIPTION	VALUE	V/W	TOL.	MFR'S DESIG	VXSTD P/N	VERS.	LOT.	SIDE	LAY ADR
C 3611	CHIP CAP.	0.01uF	25V	B	GRM39B103K25PT	K22144803		2-	B	h2
C 3612	CHIP CAP.	0.01uF	25V	B	GRM39B103K25PT	K22144803		2-	B	h2
C 3613	CHIP CAP.	0.001uF	50V	B	GRM39B102K50PT	K22174821		2-	B	h2
C 3614	CHIP CAP.	0.01uF	50V	B	GRM40B103K50PT	K22170826		2-	B	h2
C 3615	CHIP CAP.	0.01uF	25V	B	GRM39B103K25PT	K22144803		2-	A	A1
C 3616	CHIP CAP.	0.01uF	25V	B	GRM39B103K25PT	K22144803		2-	A	A1
C 3617	CHIP CAP.	0.01uF	25V	B	GRM39B103K25PT	K22144803		2-	A	A1
C 3618	CHIP CAP.	0.01uF	25V	B	GRM39B103K25PT	K22144803		2-	B	g1
C 3619	AL.ELECTRO.CAP.	470uF	16V		RE3-16V471M 470UF	K40129066		2-	A	F5
C 3620	AL.ELECTRO.CAP.	220uF	10V		RE2-10V221M 220UF	K40109018		2-	A	E4
C 3621	CHIP CAP.	0.01uF	50V	B	GRM40B103K50PT	K22170826		2-	A	E4
C 3622	CHIP CAP.	0.001uF	50V	B	GRM40B102M50PT	K22170805		2-	A	E4
C 3623	CHIP CAP.	0.1uF	25V	B	GRM40B104M25PT	K22140811		2-	B	h1
C 3624	CHIP TA.CAP.	4.7uF	25V		TESVC1E475M12R	K78140011		2-	A	D2
C 3625	CHIP TA.CAP.	4.7uF	25V		TESVC1E475M12R	K78140011		2-	A	D4
C 3626	AL.ELECTRO.CAP.	470uF	16V		RE3-16V471M 470UF	K40129066		2-	A	F1
C 3627	CHIP CAP.	0.001uF	50V	B	GRM39B102M50PT	K22174809		2-	B	g1
C 3628	CHIP CAP.	100pF	50V	CH	GRM39CH101J50PT	K22174235		2-	B	g1
C 3629	CHIP CAP.	27pF	50V	CH	GRM40CH270J50PT	K22170221		2-	A	H2
C 3633	CHIP CAP.	0.001uF	50V	B	GRM40B102M50PT	K22170805		2-	A	A4
C 3634	CHIP CAP.	0.001uF	50V	B	GRM40B102M50PT	K22170805		2-	A	A4
C 3637	CHIP CAP.	0.001uF	50V	B	GRM40B102M50PT	K22170805		2-	B	e5
C 3638	CHIP CAP.	0.001uF	50V	B	GRM40B102M50PT	K22170805		2-	B	e5
C 3639	CHIP CAP.	0.001uF	50V	B	GRM40B102M50PT	K22170805		2-	B	c1
C 3640	CHIP CAP.	0.001uF	50V	B	GRM40B102M50PT	K22170805		2-	B	d3
C 3641	CHIP CAP.	0.001uF	50V	B	GRM40B102M50PT	K22170805		2-	B	d3
C 3645	CHIP CAP.	22pF	50V	CH	GRM40CH220J50PT	K22170219		12-		
D 3001	DIODE				DAN202K T146	G2070182		1-	B	e4
D 3004	DIODE				DAN202K T146	G2070182		1	A	E1
D 3004	DIODE				D1F20-4063	G2070474		2-	A	E1
D 3005	DIODE				DAN202K T146	G2070182		1-	B	c3
D 3006	DIODE				DAN202K T146	G2070182		1	B	c1
D 3006	DIODE				D1F20-4063	G2070474		2-	B	c1
D 3007	DIODE				1SS272 TE85R	G2070048		1-	A	A3
D 3008	DIODE				1SS272 TE85R	G2070048		1-	A	D3
D 3011	DIODE				HSM83-TL	G2070572		1-	B	c5
D 3011	DIODE				1SS294 TE85R	G2070058		4-	B	c5
D 3012	DIODE				HSM83-TL	G2070572		1-	B	a1
D 3501	DIODE				DAN202K T146	G2070182		1-	B	c4
D 3502	DIODE				DAN202K T146	G2070182		2-	A	E4
D 3504	DIODE				1SS400 TE61	G2070634		2-	B	h1
D 3504	DIODE				MA2S111-(TX)	G2070614		13-	B	h1
FB3001	RFC WITH BEADS				3A RI5.8X6.4-2	L1020732		1-	A	D2
FB3501	M.RFC				FBA03VA450AB-00	L1190389		1-	A	F5
FB3502	M.RFC				FBA03VA450AB-00	L1190389		1-	A	F4
FB3503	M.RFC				FBA03VA450AB-00	L1190389		1-	A	G4
FB3504	M.RFC				FBA03VA450AB-00	L1190389		1-	A	G3
FB3505	M.RFC				FBA03VA450AB-00	L1190389		1-	A	E3
FB3506	M.RFC				FBA03VA450AB-00	L1190389		1-	A	G3
FB3507	M.RFC				FBA03VA450AB-00	L1190389		1-	A	G2
FB3508	RFC WITH BEADS				3A RI5.8X6.4-2	L1020732		1-	A	D3
FB3509	RFC WITH BEADS				3A RI5.8X6.4-2	L1020732		1-	A	D1
J 3001	CONNECTOR				TMP-J01X-A2	P1090255		1-	A	C5
J 3002	CONNECTOR				SB20-02WS	P0090609		1-	A	D5
J 3003	CONNECTOR				IMSA-9202B-1-02-T	P0091174		1-	A	D5
J 3004	CONNECTOR				12FMZ-BT	P1090901		1-	A	F5
J 3005	CONNECTOR				TMP-J01X-A2	P1090255		1-	A	A2
J 3006	CONNECTOR				SB20-02WS	P0090609		1-	A	D4
J 3007	CONNECTOR				MDC-086	P1090935		1-	A	A1
J 3008	CONNECTOR				MX328BL	P1091007		1-	A	B1
J 3009	CONNECTOR				MX345GLB	P1091008		1-	A	H1
J 3010	CONNECTOR				MX345GLB	P1091008		1-	A	G1
J 3501	CONNECTOR				TMP-J01X-A2	P1090255		1-	A	G6
J 3502	CONNECTOR				IMSA-9202B-1-02-T	P0091174		1-	A	E3
J 3503	CONNECTOR				TMP-J01X-A2	P1090255		1-	A	A3
J 3504	CONNECTOR				IMSA-9202B-1-02-T	P0091174		2-	A	D5
JP3001	WIRE ASSY				A0898 #241893	T9206728		1	A	A1
JP3001	WIRE ASSY				A0898	T9206781		2-	A	A1

REF.	DESCRIPTION	VALUE	V/W	TOL.	MFR'S DESIG	VXSTD P/N	VERS.	LOT.	SIDE	LAY ADR
JP3002	WIRE ASSY				A0898 #241894	T9206729		1-	A	G1
JP3501	JUMPER WIRE C				0.6-5.0	Q6100015		3-		
JP3502	JUMPER WIRE C				0.6-5.0	Q6100015		3-		
JP3503	JUMPER WIRE C				0.6-5.0	Q6100015		3-		
JP3504	JUMPER WIRE C				0.6-5.0	Q6100015		3-		
L 3001	M.RFC	18uH			LEM4532T180K	L1690403		1-4	A	C5
L 3002	TOROIDAL COIL	10uH			10U 3A EI9.3	L0022120		1-	A	D5
L 3005	M.RFC	10uH			CDRH74-100MC	L1690599		1-	A	D4
L 3008	TOROIDAL COIL	6uH			U 6H3 10X5X5	L0022039		1		
L 3008	COIL PWR-WIDE				D12A TR16	L0022068		2-		
L 3009	COIL A1				3.5T7.5D1.0UEW R	L0022005A		1-	A	A1
L 3010	M.RFC	3.9mH			RCR-875D-392K	L1190383		1-	A	D5
L 3011	M.RFC	3.9mH			RCR-875D-392K	L1190383		1-	A	E5
L 3012	M.RFC	470uH			RCR-875D-471K	L1190385		1-	A	E5
L 3013	M.RFC	100uH			FLC32T-101J	L1690227		2-	A	F4
L 3502	COIL A1				4.5T2.5D0.5UEW R	L0021649A		1		
L 3503	COIL A1				10.5T3.0D0.4UEW R	L0021678A		1-	A	G5
L 3505	COIL A1				4.5T2.5D0.5UEW R	L0021649A		1		
L 3506	COIL A1				10.5T3.0D0.4UEW R	L0021678A		1-	A	G4
L 3508	COIL A1				4.5T2.5D0.5UEW R	L0021649A		1		
L 3509	COIL A1				1.5T4.0D0.6UEW R	L0021711B		1		
L 3510	COIL A1				7.5T6.0D1.2UEW L	L0022157		1-	A	F4
L 3511	COIL A1				7.5T6.0D1.2UEW L	L0022157		1-	A	E4
L 3512	COIL A1				7.5T6.0D1.2UEW L	L0022157		1-	A	E2
L 3513	COIL A1				10.5T3.0D0.4UEW R	L0021678A		1-	A	G3
L 3514	COIL A1				1.5T2.0D0.5UEW R	L0021762A		1-	A	G4
L 3515	CHIP COIL	0.022uH			C2520C-22NK	L1690536		2-	A	G5
P 3001	WIRE ASSY				VIO 63(6.5)/(6.5)	T9318071		1-		
P 3002	TERMINAL				B2 AG M2.6	Q6000112		1-		
P 3003	TERMINAL				B2 AG M2.6	Q6000112		1-		
P 3004	CONNECTOR				IMSA-9206H-T	P1090988		1-		
P 3005	CONNECTOR				IMSA-9206H-T	P1090988		1-		
P 3006	WIRE ASSY				A0898	T9206750		1-		
P 3007	WIRE-ASSY				VIO45 (3)/(3)	T9318112		2-		
P 3008	CONNECTOR				IMSA-9206H-T	P1090988		2-		
Q 3001	IC				PQ09TZ1U	G1092599		1-	A	D4
Q 3002	FET				MRF9745T1	G3070189		1-	A	C5
Q 3002	FET				MRF9382T1	G3070259		21-	A	C5
Q 3003	TRANSISTOR				2SC3444-T11-1E	G3334448E		1-	B	d5
Q 3004	FET				MRF5015	G3090113		1-	A	B5
Q 3005	IC				TA78009AP	G1090720		1-	A	B4
Q 3005	IC				TA7809S	G1091711		5-	A	B4
Q 3007	FET				MRF255	G3090120		1-	A	B3
Q 3008	FET				MRF255	G3090120		1-	A	C3
Q 3009	IC				M5223FP-600C	G1090990		1	B	c2
Q 3009	IC				M5223AFP 600C	G1092955		2-	B	c2
Q 3010	TRANSISTOR				2SC2812L6-TA	G3328127F		1-	B	c1
Q 3010	TRANSISTOR				2SC2812NL6-TB	G3328128F		19-	B	c1
Q 3011	IC				IR3M03N2	G1091300		1-	B	c5
Q 3012	TRANSISTOR				2SC3444-T11-1E	G3334448E		1-	B	a1
Q 3501	TRANSISTOR				MRF581	G3090114		1-	A	G5
Q 3502	TRANSISTOR				MRF559	G3090070		1-	A	G4
Q 3503	TRANSISTOR				MRF555	G3090115		1-	A	H4
Q 3504	FET				MRF5015	G3090113		1-	A	G2
Q 3505	FET				SRF7043	G3090124		1-	A	F3
Q 3506	IC				PQ09TZ1U	G1092599		1-	A	F4
Q 3507	TRANSISTOR				2SD1205R	G3412050R		2	A	D4
Q 3507	TRANSISTOR				2SD1205A-R	G3412051R		3-	A	D4
R 3001	CHIP RES.	330	1/10W	5%	RMC1/10T 331J	J24205331		1-	B	e5
R 3002	CHIP RES.	5.6	1/10W	5%	RMC1/10T 5R6J	J24205569		1-	B	e5
R 3003	CHIP RES.	330	1/10W	5%	RMC1/10T 331J	J24205331		1-	B	e5
R 3004	CHIP RES.	220	1/10W	5%	RMC1/10T 221J	J24205221		1-	B	f5
R 3005	CHIP RES.	6.8k	1/10W	5%	RMC1/10T 682J	J24205682		1	B	f5
R 3005	CHIP RES.	0	1/10W	5%	RMC1/10T 000J	J24205000		2-	B	f5
R 3006	CHIP RES.	1.8k	1/10W	5%	RMC1/10T 182J	J24205182		1-	B	f5
R 3007	CHIP RES.	330	1/10W	5%	RMC1/10T 331J	J24205331		1-	B	f5
R 3008	CHIP RES.	470	1/4W	5%	RMC1/4 471JATP	J24245471		1-	B	f5
R 3009	CHIP RES.	820	1/10W	5%	RMC1/10T 821J	J24205821		1-	B	d5

PA Unit

REF.	DESCRIPTION	VALUE	V/W	TOL.	MFR'S DESIG	VXSTD P/N	VERS.	LOT.	SIDE	LAY ADR
R 3010	CHIP RES.	470	1/10W	5%	RMC1/10T 471J	J24205471		1-	B	d5
R 3012	CHIP RES.	2.2k	1/10W	5%	RMC1/10T 222J	J24205222		1-	B	f5
R 3012	CHIP RES.	1.8k	1/10W	5%	RMC1/10T 182J	J24205182		14-	B	f5
R 3013	CHIP RES.	1.5k	1/10W	5%	RMC1/10T 152J	J24205152		1-	A	B5
R 3013	CHIP RES.	1.8k	1/10W	5%	RMC1/10T 182J	J24205182		14-	A	B5
R 3014	CHIP RES.	220	1W	5%	RMC1 221JTE	J24305221		1-	A	A5
R 3016	CHIP RES.	470	1W	5%	RMC1 471JTE	J24305471		1-	B	e5
R 3027	CHIP RES.	47	1W	5%	RMC1 470JTE	J24305470		1-	B	f3
R 3028	CHIP RES.	47	1W	5%	RMC1 470JTE	J24305470		1-	B	f3
R 3029	CHIP RES.	1k	1/10W	5%	RMC1/10T 102J	J24205102		1-	A	B3
R 3029	CHIP RES.	1.2k	1/10W	5%	RMC1/10T 122J	J24205122		14-	A	B3
R 3030	CHIP RES.	1k	1/10W	5%	RMC1/10T 102J	J24205102		1-	A	D3
R 3030	CHIP RES.	1.2k	1/10W	5%	RMC1/10T 122J	J24205122		14-	A	D3
R 3031	CHIP RES.	1k	1/10W	5%	RMC1/10T 102J	J24205102		1-	B	c2
R 3032	CHIP RES.	220k	1/10W	1%	RMC1/10 2203FTP	J24209041		1-	B	c2
R 3033	CHIP RES.	220k	1/10W	1%	RMC1/10 2203FTP	J24209041		1-	B	c2
R 3034	CHIP RES.	5.6k	1/10W	0.1%	RR1220P-562-B	J24209092		1-	B	c2
R 3035	CHIP RES.	5.6k	1/10W	0.1%	RR1220P-562-B	J24209092		1-	B	c2
R 3036	CHIP RES.	4.7k	1/10W	5%	RMC1/10T 472J	J24205472		1-	B	d3
R 3037	CHIP RES.	4.7	2W	5%	CMT2T 4.7 J1000	J24339017		1		
R 3038	CHIP RES.	5.6k	1/10W	0.1%	RR1220P-562-B	J24209092		1-	B	c1
R 3039	CHIP RES.	4.7k	1/10W	5%	RMC1/10T 472J	J24205472		1-	B	d3
R 3040	CHIP RES.	5.6k	1/10W	0.1%	RR1220P-562-B	J24209092		1-	B	c1
R 3041	CHIP RES.	6.8k	1/10W	0.1%	RR1220P-682-B	J24209094		1-	B	c1
R 3042	CHIP RES.	6.8k	1/10W	0.1%	RR1220P-682-B	J24209094		1-	B	c1
R 3043	CHIP RES.	100	2W	5%	CMT2T 100 J1000	J24339049		1-	A	C3
R 3044	CHIP RES.	22	1W	5%	RMC1 220JTE	J24305220		1-	A	A3
R 3045	CHIP RES.	22	1W	5%	RMC1 220JTE	J24305220		1-	A	D3
R 3046	CHIP RES.	2.2k	1/10W	5%	RMC1/10T 222J	J24205222		1-	A	A3
R 3046	CHIP RES.	1.8k	1/10W	5%	RMC1/10T 182J	J24205182		14-	A	A3
R 3047	CHIP RES.	2.2k	1/10W	5%	RMC1/10T 222J	J24205222		1-	A	D3
R 3047	CHIP RES.	1.8k	1/10W	5%	RMC1/10T 182J	J24205182		14-	A	D3
R 3048	CHIP RES.	4.7	1/4W	5%	RMC1/4 4R7JATP	J24245479		1-	B	d5
R 3049	CHIP RES.	4.7	1/4W	5%	RMC1/4 4R7JATP	J24245479		1-	B	d5
R 3050	CHIP RES.	1k	1/16W	1%	RMC1/16 102FTP	J24183102		1-	B	d5
R 3051	CHIP RES.	6.2k	1/16W	1%	RMC1/16 622FTP	J24183622		1-	B	d5
R 3052	CHIP RES.	4.7k	1/10W	5%	RMC1/10T 472J	J24205472		1-	B	a1
R 3052	CHIP RES.	2.2k	1/10W	5%	RMC1/10T 222J	J24205222		6-	B	a1
R 3053	CHIP RES.	1k	1/10W	5%	RMC1/10T 102J	J24205102		1-	B	a1
R 3053	CHIP RES.	22k	1/10W	5%	RMC1/10T 223J	J24205223		6-	B	a1
R 3054	CHIP RES.	4.7k	1/10W	5%	RMC1/10T 472J	J24205472		1-	B	c1
R 3055	CHIP RES.	10k	1/10W	5%	RMC1/10T 103J	J24205103		1-	B	c1
R 3056	CHIP RES.	470	1/10W	5%	RMC1/10T 471J	J24205471		1-	A	F4
R 3056	CHIP RES.	6.8k	1/10W	5%	RMC1/10T 682J	J24205682		41-	A	F4
R 3057	CHIP RES.	820	1/10W	5%	RMC1/10T 821J	J24205821		1-	A	F5
R 3057	CHIP RES.	6.8k	1/10W	5%	RMC1/10T 682J	J24205682		41-	A	F5
R 3058	CHIP RES.	3.3	1W	5%	RMC1 3R3JTE	J24305339		2-	A	E2
R 3059	CHIP RES.	33	1/2W	5%	RMC1/2 330JCTP	J24275330		5-		
R 3501	CHIP RES.	1.5k	1/10W	5%	RMC1/10T 152J	J24205152		1	B	a5
R 3501	CHIP RES.	330	1/10W	5%	RMC1/10T 331J	J24205331		2-	B	a5
R 3502	CHIP RES.	120	1/10W	5%	RMC1/10T 121J	J24205121		1	A	G5
R 3502	CHIP RES.	47	1/10W	5%	RMC1/10T 470J	J24205470		2-	A	G5
R 3503	CHIP RES.	2.7k	1/10W	5%	RMC1/10T 272J	J24205272		1	A	G5
R 3503	CHIP RES.	1k	1/10W	5%	RMC1/10T 102J	J24205102		2-	A	G5
R 3504	CHIP RES.	100	1/10W	5%	RMC1/10T 101J	J24205101		1-	A	G4
R 3505	CHIP RES.	1.5k	1/10W	5%	RMC1/10T 152J	J24205152		1	B	a5
R 3505	CHIP RES.	330	1/10W	5%	RMC1/10T 331J	J24205331		2-	B	a5
R 3506	CHIP RES.	2.7k	1/10W	5%	RMC1/10T 272J	J24205272		1	A	G4
R 3506	CHIP RES.	1k	1/10W	5%	RMC1/10T 102J	J24205102		2-	A	G4
R 3507	CHIP RES.	100	1/4W	5%	RMC1/4 101JATP	J24245101		1	A	H3
R 3507	CHIP RES.	68	1/4W	5%	RMC1/4 680JATP	J24245680		2-	A	H3
R 3508	CHIP RES.	220	1/10W	5%	RMC1/10T 221J	J24205221		1-	B	a4
R 3509	CHIP RES.	1k	1/10W	5%	RMC1/10T 102J	J24205102		1	A	G4
R 3509	CHIP RES.	1.2k	1/10W	5%	RMC1/10T 122J	J24205122		2-	A	G4
R 3510	CHIP RES.	3.3k	1/10W	5%	RMC1/10T 332J	J24205332		1	A	H2
R 3510	CHIP RES.	1.5k	1/10W	5%	RMC1/10T 152J	J24205152		2	A	H2
R 3510	CHIP RES.	1.8k	1/10W	5%	RMC1/10T 182J	J24205182		3-	A	H2
R 3511	CHIP RES.	2.2k	1/10W	5%	RMC1/10T 222J	J24205222		1-	B	a2

REF.	DESCRIPTION	VALUE	V/W	TOL.	MFR'S DESIG	VXSTD P/N	VERS.	LOT.	SIDE	LAY ADR
R 3512	CHIP RES.	56	1W	5%	RMC1 560JTE	J24305560		1-	B	b2
R 3513	CHIP RES.	22k	1/10W	5%	RMC1/10T 223J	J24205223		1-	A	F3
R 3514	CHIP RES.	150	1/4W	5%	RMC1/4 151JATP	J24245151		1-	B	b3
R 3515	CHIP RES.	150	1/4W	5%	RMC1/4 151JATP	J24245151		1-	B	b2
R 3516	CHIP RES.	22k	1/10W	5%	RMC1/10T 223J	J24205223		1	A	F4
R 3516	CHIP RES.	27k	1/10W	5%	RMC1/10T 273J	J24205273		2-	A	F4
R 3516	CHIP RES.	22k	1/10W	5%	RMC1/10T 223J	J24205223		7-	A	F4
R 3517	CHIP RES.	22k	1/10W	5%	RMC1/10T 223J	J24205223		1-	A	F2
R 3518	CHIP RES.	47	1/10W	5%	RMC1/10T 470J	J24205470		1	A	G5
R 3518	CHIP RES.	100	1/10W	5%	RMC1/10T 101J	J24205101		2-	A	G5
R 3519	CHIP RES.	47	1/4W	5%	RMC1/4 470JATP	J24245470		1		
R 3520	CHIP RES.	1.2k	1/10W	5%	RMC1/10T 122J	J24205122		1	B	b5
R 3520	CHIP RES.	220	1/10W	5%	RMC1/10T 221J	J24205221		2-	B	b5
R 3521	CHIP RES.	68	1/10W	5%	RMC1/10T 680J	J24205680		1-	B	a5
R 3522	CHIP RES.	68	1/10W	5%	RMC1/10T 680J	J24205680		1-	B	b5
R 3523	CHIP RES.	4.7	1/2W	5%	RMC1/2 4R7JCTP	J24275479		1-	B	a3
R 3524	CHIP RES.	1k	1/8W	5%	RMC1/8T 102J	J24215102		1-	B	a3
R 3525	CHIP RES.	1.2k	1/10W	5%	RMC1/10T 122J	J24205122		1	B	b4
R 3525	CHIP RES.	220	1/10W	5%	RMC1/10T 221J	J24205221		2-	B	b4
R 3526	CHIP RES.	68	1/10W	5%	RMC1/10T 680J	J24205680		1	B	b4
R 3526	CHIP RES.	47	1/10W	5%	RMC1/10T 470J	J24205470		2-	B	b4
R 3527	CHIP RES.	68	1/10W	5%	RMC1/10T 680J	J24205680		1	B	b4
R 3527	CHIP RES.	47	1/10W	5%	RMC1/10T 470J	J24205470		2-	B	b4
R 3528	CHIP RES.	1k	1/4W	5%	RMC1/4 102JATP	J24245102		1	A	E3
R 3529	CHIP RES.	1k	1/4W	5%	RMC1/4 102JATP	J24245102		1	A	D2
R 3531	CHIP RES.	39	1W	5%	ERJ1WYJ390U	J24309010		2-	B	d5
R 3532	CHIP RES.	1.8	1/4W	5%	RMC1/4 1R8JATP	J24245189		2-	B	d4
R 3533	CHIP RES.	33k	1/10W	5%	RMC1/10T 333J	J24205333		2-	A	D4
R 3534	CHIP RES.	33k	1/10W	5%	RMC1/10T 333J	J24205333		2-	A	D4
R 3535	CHIP RES.	3.3k	1/16W	5%	RMC1/16 332JATP	J24185332		2-	A	A2
R 3536	CHIP RES.	15k	1/16W	5%	RMC1/16 153JATP	J24185153		2-	B	h1
R 3537	CHIP RES.	100	1/10W	5%	RMC1/10T 101J	J24205101		2-	B	b5
R 3538	CHIP RES.	68	1/10W	5%	RMC1/10T 680J	J24205680		2-	A	G5
RL3001	RELAY		DC12V		ACP131 DC12V	M1190152		1-	A	E1
T 3001	COIL 07WIDE				4-1 3A6 RIB4X7	L0022396		1-	A	B5
T 3002	COIL PWR-WIDE				3A5 RIB10X20X10	L0022551		1-	A	C4
T 3003	COIL PWR-WIDE				3A5 RIB16X32X16	L0022465		1-	A	C1
T 3004	TOROIDAL COIL				D12A RI16X8X8	L0022119		1-	A	F1
T 3501	COIL PWR-WIDE				A0898	L0022552		1-	A	H3
T 3502	COIL WIDE-TRANS.				18-OHM BLU 110	L0022553		1	A	G3
T 3502	COIL WIDE-TRANS.				18-OHM BLU 100	L0022553A		2-	A	G3
T 3503	COIL WIDE-TRANS.				18-OHM BLU 110	L0022553		1	A	G2
T 3503	COIL WIDE-TRANS.				18-OHM BLU 100	L0022553A		2-	A	G2
T 3504	COIL WIDE-TRANS.				16-OHM YEL 110	L0022554		1		
T 3504	COIL WIDE-TRANS.				16-OHM YEL 70	L0022554A		2-		
T 3505	COIL WIDE-TRANS.				16-OHM YEL 110	L0022554		1		
T 3505	COIL WIDE-TRANS.				16-OHM YEL 70	L0022554A		2-		
T 3506	COIL WIDE-TRANS.				50-OHM GRA 140	L0022574		1-		
TH3001	THERMISTOR				157-502-53002TP	G9090049		1-	A	F3
TH3002	THERMISTOR				157-502-53002TP	G9090049		1-	A	D3
TP3001	TERMINAL				TP-K IPS-1136	Q5000050		1		
TP3002	TERMINAL				TP-K IPS-1136	Q5000050		1-	A	G1
VR3001	POT.	2.2k			RH03A3AJ3X 2.2K	J51807222		1-	A	C5
VR3002	POT.	4.7k			RH03A3AS3X 4.7K	J51807472		1-	A	A4
VR3003	POT.	4.7k			RH03A3AS3X 4.7K	J51807472		1-	A	D3
VR3004	POT.	22k			RH03A3AJ4X 22K	J51807223		2-	A	C5
VR3501	POT.	2.2k			RH03A3AJ3X 2.2K	J51807222		1-	A	G4
VR3502	POT.	10k			RH03A3A14X 10K	J51807103		1-	A	F4
VR3502	POT.	22k			RH03A3AJ4X 22K	J51807223		7-	A	F4
	GROUND PLATE					RA0015200		1-		
	GROUND PLATE					RA0015200		1-		
	SHIELD PLATE					RA0109500		2-		
	GROUND PLATE					RA0015200		2-		
	LEAF SPRING					R0113730		2-		
	PAD					RA0115600		2-		
	PAD					RA0120300		2-		

PA Unit

Note:

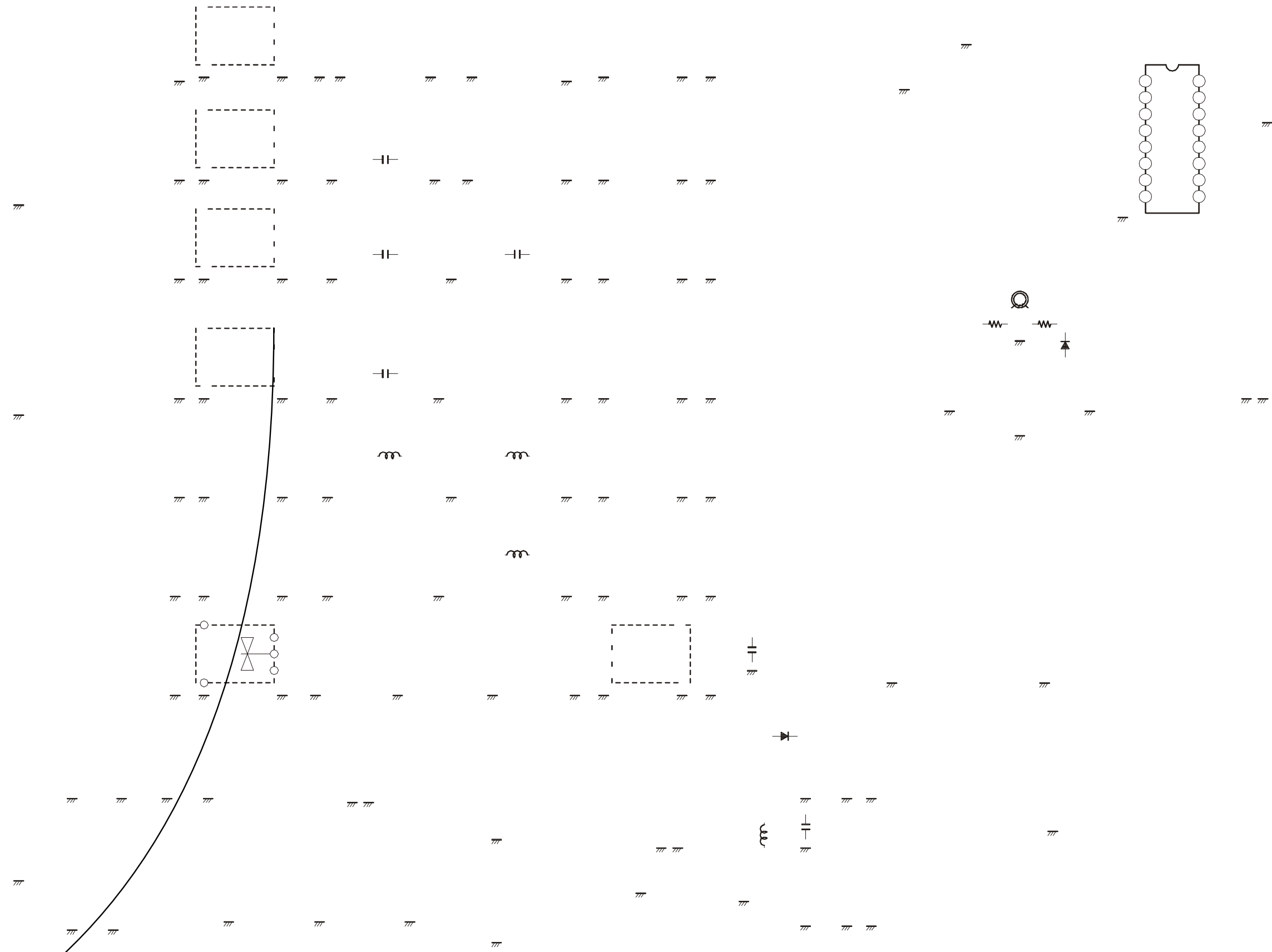

LPF Unit

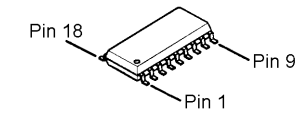
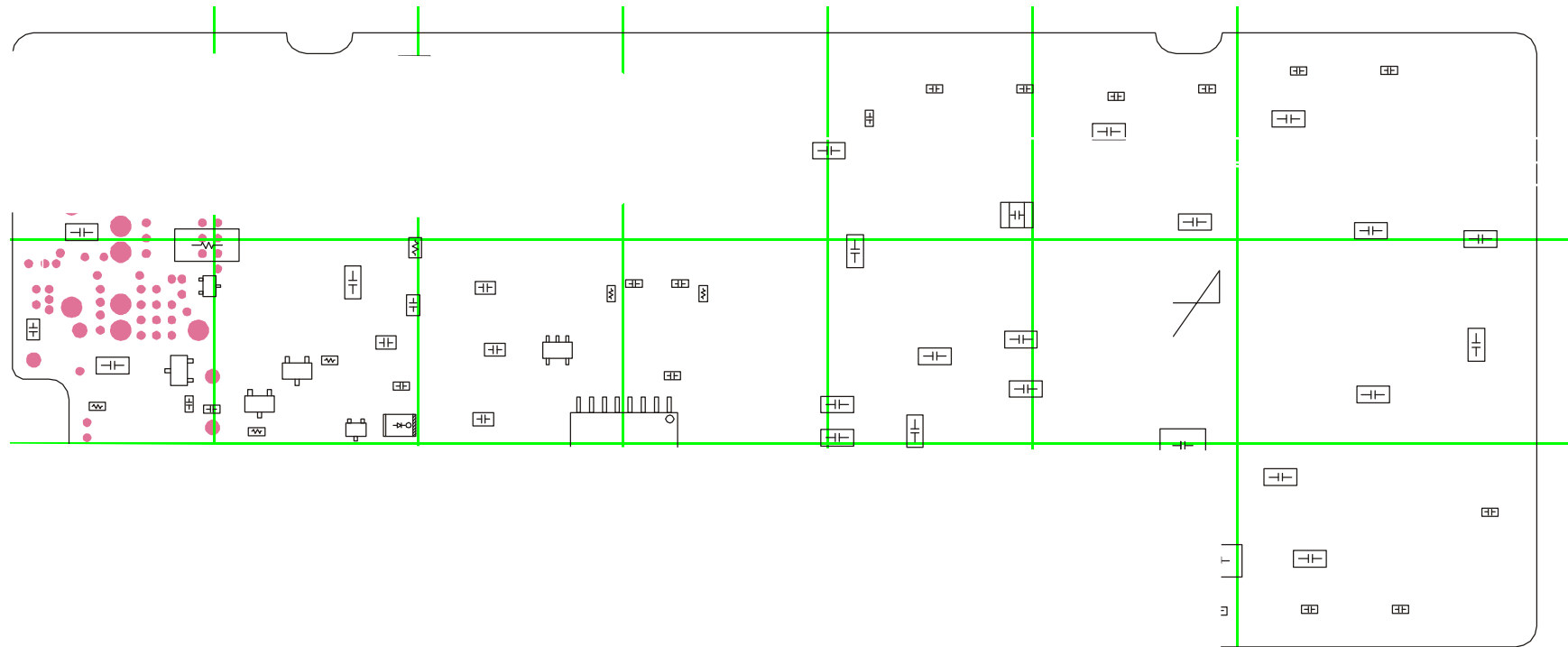
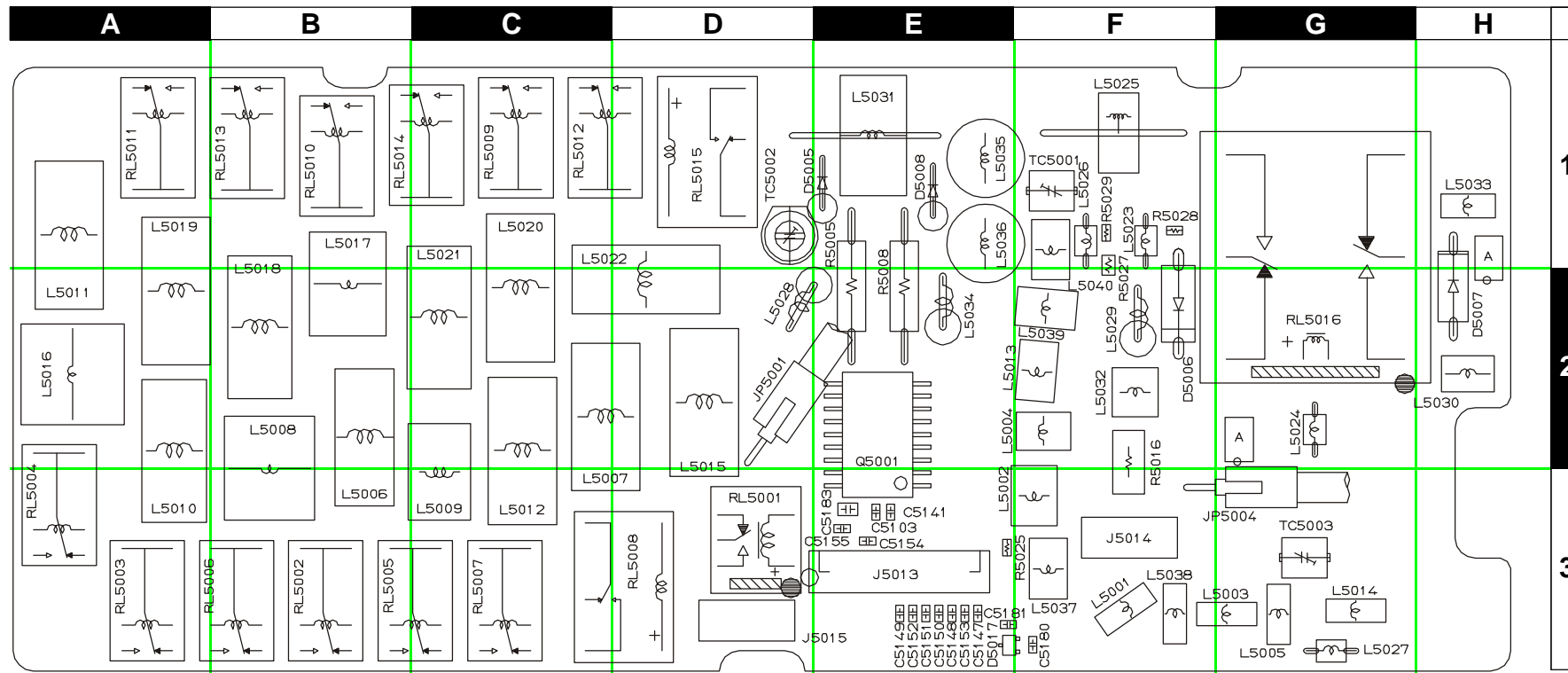

TD62783F (Q5001)

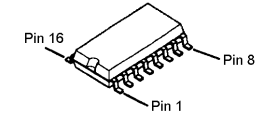

MC14028BFL (Q5002)

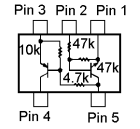

FMC5A (C5) (Q5003, 5004)

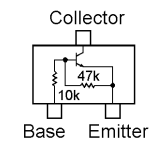

2SC4047 (ZY) (Q5005, 5006, 5007)

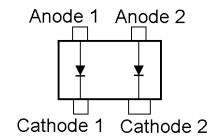

DA227 (N20) (D5014)

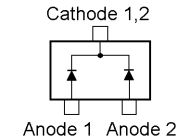

DAN202U (N) (D5011, 5018)

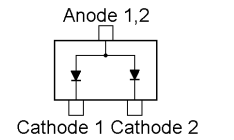

DAP202U (P) (D5016, 5017) DAP236U (X) (D5021)

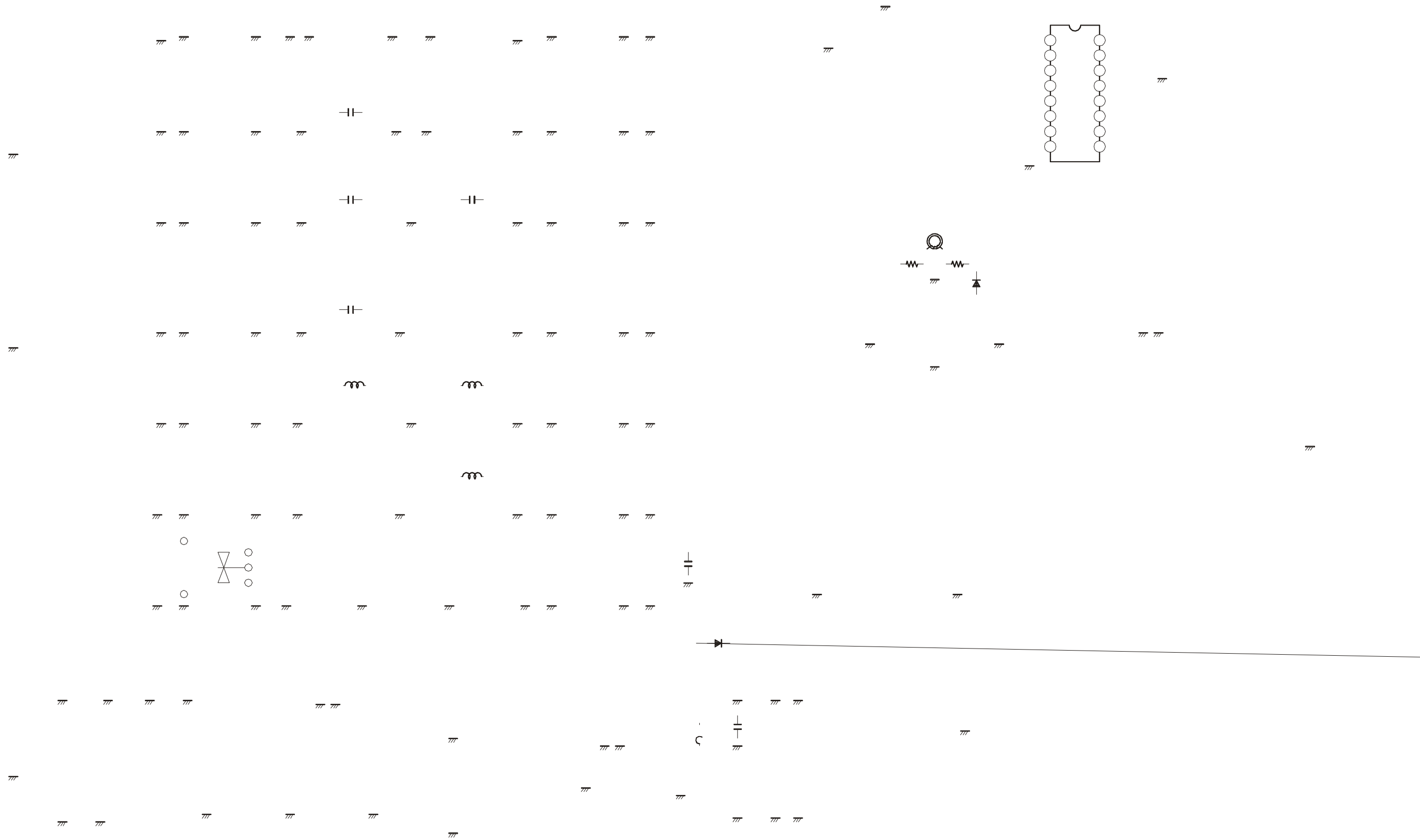



Parts List

REF.	DESCRIPTION	VALUE	V/W	TOL.	MFR'S DESIG	VXSTD P/N	VERS.	LOT.	SIDE	LAY ADR
*** LPF-UNIT ***										
PCB with Components						CS1620001				
Printed Circuit Board						FR001680E		1-		
Printed Circuit Board						FR001680G		9-		
C 5001	CHIP CAP.	0.047uF	25V	F	GRM39F473Z25PT	K22145002		1-	B	d3
C 5002	CHIP CAP.	0.047uF	25V	F	GRM39F473Z25PT	K22145002		1-	B	f3
C 5003	CHIP CAP.	0.047uF	25V	F	GRM39F473Z25PT	K22145002		1-	B	g3
C 5004	CHIP CAP.	0.047uF	25V	F	GRM39F473Z25PT	K22145002		1-	B	h3
C 5005	CHIP CAP.	0.047uF	25V	F	GRM39F473Z25PT	K22145002		1-	B	f3
C 5006	CHIP CAP.	0.047uF	25V	F	GRM39F473Z25PT	K22145002		1-	B	g3
C 5007	CHIP CAP.	0.047uF	25V	F	GRM39F473Z25PT	K22145002		1-	B	f3
C 5008	CHIP CAP.	0.047uF	25V	F	GRM39F473Z25PT	K22145002		1-	B	e3
C 5009	CHIP CAP.	8pF	200V	CH	GRM40CH080D200PT	K22230214		1-	B	c3
C 5010	CHIP CAP.	5pF	200V	CH	GRM40CH050C200PT	K22230207		1-	B	b3
C 5011	CHIP CAP.	18pF	200V	CH	GRM40CH180J200PT	K22230219		1-	B	c3
C 5012	CHIP CAP.	7pF	200V	CH	GRM40CH070D200PT	K22230213		1-	B	b3
C 5014	CHIP CAP.	6pF	200V	CH	GRM40CH060D200PT	K22230212		1	B	b3
C 5014	CHIP CAP.	7pF	200V	CH	GRM40CH070D200PT	K22230213		2-	B	b3
C 5017	CHIP CAP.	18pF	200V	CH	GRM40CH180J200PT	K22230219		1-	B	c2
C 5018	CHIP CAP.	6pF	200V	CH	GRM40CH060D200PT	K22230212		1	B	b3
C 5018	CHIP CAP.	7pF	200V	CH	GRM40CH070D200PT	K22230213		2-	B	b3
C 5022	CHIP CAP.	82pF	500V	CH	CF316CH820J500AT	K22271266		1-	B	g3
C 5023	CHIP CAP.	68pF	500V	CH	CF316CH680J500AT	K22271265		1-	B	f3
C 5024	CHIP CAP.	18pF	500V	CH	CF316CH180J500AT	K22271258		1-	B	e3
C 5027	CHIP CAP.	22pF	500V	CH	CF316CH220J500AT	K22271259		1-	B	e2
C 5028	CHIP CAP.	22pF	500V	CH	CF316CH220J500AT	K22271259		1-	B	e2
C 5029	CHIP CAP.	100pF	500V	CH	CF316CH101J500AT	K22271267		1-	B	g2
C 5030	CHIP CAP.	39pF	500V	CH	CF316CH390J500AT	K22271262		1-	B	h2
C 5031	CHIP CAP.	47pF	500V	CH	CF316CH470J500AT	K22271263		1-	B	f2
C 5032	CHIP CAP.	47pF	500V	CH	CF316CH470J500AT	K22271263		1-	B	g3
C 5033	CHIP CAP.	39pF	500V	CH	CF316CH390J500AT	K22271262		1-	B	f3
C 5035	CHIP CAP.	68pF	500V	CH	CF316CH680J500AT	K22271265		1-	B	e2
C 5035	CHIP CAP.	56pF	500V	CH	CF316CH560J500AT	K22271264		3-	B	e2
C 5036	CHIP CAP.	18pF	200V	CH	GRM40CH180J200PT	K22230219		1-	B	c2
C 5037	CHIP CAP.	6pF	200V	CH	GRM40CH060D200PT	K22230212		1	B	b3
C 5037	CHIP CAP.	7pF	200V	CH	GRM40CH070D200PT	K22230213		2-	B	b3
C 5048	CHIP CAP.	12pF	500V	CH	CF316CH120J500AT	K22271256		1-	B	e2
C 5052	CHIP CAP.	100pF	500V	CH	CF316CH101J500AT	K22271267		1-	B	g1
C 5053	CHIP CAP.	120pF	500V	CH	CF32CH121J500AT	K22275247		1-	B	e1
C 5054	CHIP CAP.	18pF	500V	CH	CF316CH180J500AT	K22271258		1-	B	h2
C 5055	CHIP CAP.	12pF	500V	CH	CF316CH120J500AT	K22271256		1-	B	f1
C 5056	CHIP CAP.	39pF	200V	CH	GRM40CH390J200PT	K22230223		1	B	c2
C 5056	CHIP CAP.	22pF	200V	CH	GRM40CH220J200PT	K22230220		2-	B	c2
C 5057	CHIP CAP.	6pF	200V	CH	GRM40CH060D200PT	K22230212		1	B	a3
C 5057	CHIP CAP.	7pF	200V	CH	GRM40CH070D200PT	K22230213		2-	B	a3
C 5059	CHIP CAP.	82pF	500V	CH	CF316CH820J500AT	K22271266		1-	B	e2
C 5062	CHIP CAP.	4pF	500V	CH	CF316CH040C500AT	K22271249		1-	B	e2
C 5066	CHIP CAP.	100pF	500V	CH	CF316CH101J500AT	K22271267		1-	B	g1
C 5067	CHIP CAP.	39pF	500V	CH	CF316CH390J500AT	K22271262		1-	B	f1
C 5069	CHIP CAP.	47pF	200V	CH	GRM40CH470J200PT	K22230224		1-	B	b1
C 5070	CHIP CAP.	10pF	500V	CH	CF316CH100D500AT	K22271255		1-	B	d1
C 5071	CHIP CAP.	0.001uF	50V	B	GRM39B102K50PT	K22174821		1-	B	b1
C 5072	CHIP CAP.	0.01uF	25V	B	GRM39B103K25PT	K22144803		1-	B	b1
C 5073	CHIP CAP.	0.001uF	50V	B	GRM39B102K50PT	K22174821		1-	B	a2
C 5074	CHIP CAP.	0.001uF	50V	B	GRM39B102K50PT	K22174821		1-	B	a2
C 5075	CHIP CAP.	0.001uF	50V	B	GRM39B102K50PT	K22174821		1-	B	c1
C 5076	CHIP CAP.	0.01uF	25V	B	GRM39B103K25PT	K22144803		1-	B	c1
C 5077	CHIP CAP.	0.001uF	50V	B	GRM39B102K50PT	K22174821		1-	B	a3
C 5078	CHIP CAP.	0.001uF	50V	B	GRM39B102K50PT	K22174821		1-	B	a3
C 5079	CHIP CAP.	0.047uF	25V	F	GRM39F473Z25PT	K22145002		1-	B	e1
C 5080	CHIP CAP.	0.047uF	25V	F	GRM39F473Z25PT	K22145002		1-	B	f1
C 5081	CHIP CAP.	0.047uF	25V	F	GRM39F473Z25PT	K22145002		1-	B	g1
C 5082	CHIP CAP.	0.047uF	25V	F	GRM39F473Z25PT	K22145002		1-	B	e1
C 5083	CHIP CAP.	0.047uF	25V	F	GRM39F473Z25PT	K22145002		1-	B	g1
C 5084	CHIP CAP.	0.047uF	25V	F	GRM39F473Z25PT	K22145002		1-	B	f1
C 5085	CHIP CAP.	0.047uF	25V	F	GRM39F473Z25PT	K22145002		1-	B	e1
C 5087	CHIP CAP.	0.001uF	200V	SL	GRM42-6SL102J200PT	K22231104		1-	B	b1
C 5088	CHIP CAP.	0.001uF	200V	SL	GRM42-6SL102J200PT	K22231104		1-	B	a2

LPF Unit

REF.	DESCRIPTION	VALUE	V/W	TOL.	MFR'S DESIG	VXSTD P/N	VERS.	LOT.	SIDE	LAY ADR
C 5090	CHIP CAP.	0.01uF	50V	B	GRM40B103M50PT	K22170817		1-	B	b2
C 5091	CHIP CAP.	0.01uF	50V	B	GRM40B103M50PT	K22170817		1-	B	a2
C 5092	CHIP CAP.	0.047uF	25V	F	GRM39F473Z25PT	K22145002		1-	B	d2
C 5093	CHIP CAP.	0.047uF	25V	F	GRM39F473Z25PT	K22145002		1-	B	d2
C 5094	CHIP CAP.	22pF	200V	CH	GRM40CH220J200PT	K22230220		1-	B	b2
C 5095	CHIP CAP.	7pF	200V	CH	GRM40CH070D200PT	K22230213		1-	B	a1
C 5096	CHIP CAP.	0.001uF	200V	SL	GRM42-6SL102J200PT	K22231104		1-	B	b2
C 5097	CHIP CAP.	0.001uF	200V	SL	GRM42-6SL102J200PT	K22231104		1-	B	a1
C 5098	CHIP CAP.	0.047uF	25V	F	GRM39F473Z25PT	K22145002		1-	B	d2
C 5099	CHIP CAP.	22pF	50V	CH	GRM39CH220J50PT	K22174219		1-	B	b2
C 5100	CHIP CAP.	7pF	50V	CH	GRM39CH070D50PT	K22174208		1-	B	a1
C 5101	CHIP CAP.	10pF	500V	CH	CF316CH100D500AT	K22271255		1-	B	c1
C 5103	CHIP CAP.	0.047uF	25V	F	GRM39F473Z25PT	K22145002		1-	A	E3
C 5108	CHIP CAP.	680pF	500V	CH	CF43CH681J500AT	K22277218		1-	B	f3
C 5109	CHIP CAP.	680pF	500V	CH	CF43CH681J500AT	K22277218		1-	B	f3
C 5110	CHIP CAP.	180pF	500V	CH	CF43CH181J500AT	K22277204		1-	B	f3
C 5111	CHIP CAP.	0.001uF	500V	CH	CF43CH102J500AT	K22277222		1-	B	f2
C 5112	CHIP CAP.	0.001uF	500V	CH	CF43CH102J500AT	K22277222		1-	B	f2
C 5113	CHIP CAP.	220pF	500V	CH	CF43CH221J500AT	K22277206		1-	B	f2
C 5114	CHIP CAP.	470pF	500V	CH	CF43CH471J500AT	K22277214		1-	B	f2
C 5115	CHIP CAP.	0.001uF	500V	CH	CF43CH102J500AT	K22277222		1-	B	e1
C 5116	CHIP CAP.	680pF	500V	CH	CF43CH681J500AT	K22277218		1-	B	g3
C 5117	CHIP CAP.	560pF	500V	CH	CF43CH561J500AT	K22277216		1-	B	g2
C 5118	CHIP CAP.	560pF	500V	CH	CF43CH561J500AT	K22277216		1-	B	g2
C 5119	CHIP CAP.	330pF	500V	CH	CF43CH331J500AT	K22277210		1-	B	g2
C 5120	CHIP CAP.	560pF	500V	CH	CF43CH561J500AT	K22277216		1-	B	f1
C 5121	CHIP CAP.	390pF	500V	CH	CF43CH391J500AT	K22277212		1-	B	h3
C 5122	CHIP CAP.	680pF	500V	CH	CF43CH681J500AT	K22277218		1-	B	h1
C 5123	CHIP CAP.	330pF	500V	CH	CF43CH331J500AT	K22277210		1-	B	g1
C 5124	CHIP CAP.	180pF	500V	CH	CF43CH181J500AT	K22277204		1-	B	e2
C 5125	CHIP CAP.	330pF	500V	CH	CF43CH331J500AT	K22277210		1-	B	e2
C 5126	CHIP CAP.	150pF	500V	CH	CF32CH151J500AT	K22275249		1-	B	e2
C 5127	CHIP CAP.	220pF	500V	CH	CF43CH221J500AT	K22277206		1-	B	g2
C 5128	CHIP CAP.	160pF	500V	CH	CF43CH161J500AT	K22277203		1-	B	f1
C 5129	CHIP CAP.	220pF	500V	CH	CF43CH221J500AT	K22277206		1-	B	c1
C 5130	CHIP CAP.	220pF	500V	CH	CF43CH221J500AT	K22277206		1-	B	d1
C 5131	CHIP CAP.	0.047uF	25V	F	GRM39F473Z25PT	K22145002		1-	B	a2
C 5132	CHIP CAP.	0.001uF	50V	B	GRM39B102K50PT	K22174821		1-	B	c1
C 5133	CHIP CAP.	0.1uF	16V	B	GRM39B104K16PT	K22124805		1-	B	c1
C 5134	CHIP CAP.	0.01uF	200V	X7R	GRM42-6X7R103K200PT	K22231802		1-	B	c1
C 5136	CHIP CAP.	0.1uF	200V	X7R	GRM43-2X7R104K200PT	K22237801		1-	B	c1
C 5137	CHIP CAP.	0.001uF	50V	B	GRM39B102K50PT	K22174821		1-	B	d3
C 5138	CHIP CAP.	0.001uF	50V	B	GRM39B102K50PT	K22174821		1-	B	d3
C 5139	CHIP CAP.	0.001uF	50V	B	GRM39B102K50PT	K22174821		1-	B	a2
C 5140	CHIP CAP.	0.001uF	50V	B	GRM39B102K50PT	K22174821		1-	B	d2
C 5141	CHIP CAP.	0.001uF	50V	B	GRM39B102K50PT	K22174821		1-	A	E3
C 5142	CHIP CAP.	0.001uF	50V	B	GRM39B102K50PT	K22174821		1-	B	a2
C 5143	CHIP CAP.	0.001uF	50V	B	GRM39B102K50PT	K22174821		1-	B	b2
C 5144	CHIP CAP.	0.01uF	25V	B	GRM39B103K25PT	K22144803		1-	B	d3
C 5145	CHIP CAP.	0.001uF	50V	B	GRM39B102K50PT	K22174821		1-	B	c2
C 5146	CHIP CAP.	0.001uF	50V	B	GRM39B102K50PT	K22174821		1-	B	c3
C 5147	CHIP CAP.	0.01uF	25V	B	GRM39B103K25PT	K22144803		1-	A	E3
C 5148	CHIP CAP.	0.01uF	25V	B	GRM39B103K25PT	K22144803		1-	A	E3
C 5149	CHIP CAP.	0.01uF	25V	B	GRM39B103K25PT	K22144803		1-	A	E3
C 5150	CHIP CAP.	0.01uF	25V	B	GRM39B103K25PT	K22144803		1-	A	E3
C 5151	CHIP CAP.	0.01uF	25V	B	GRM39B103K25PT	K22144803		1-	A	E3
C 5152	CHIP CAP.	0.01uF	25V	B	GRM39B103K25PT	K22144803		1-	A	E3
C 5153	CHIP CAP.	0.01uF	25V	B	GRM39B103K25PT	K22144803		1-	A	E3
C 5154	CHIP CAP.	0.01uF	25V	B	GRM39B103K25PT	K22144803		1-	A	E3
C 5155	CHIP CAP.	0.01uF	25V	B	GRM39B103K25PT	K22144803		1-	A	E3
C 5156	CHIP CAP.	3pF	200V	CJ	GRM40CJ030C200PT	K22230210		1	B	a2
C 5157	CHIP CAP.	0.5pF	50V	CK	GRM40CK0R5C50PT	K22170201		1-	B	a3
C 5158	CHIP CAP.	0.5pF	50V	CK	GRM40CK0R5C50PT	K22170201		1-	B	a3
C 5159	CHIP CAP.	0.01uF	25V	B	GRM39B103K25PT	K22144803		1-	B	c1
C 5160	CHIP CAP.	0.001uF	50V	B	GRM39B102K50PT	K22174821		1-	B	b1
C 5161	CHIP CAP.	0.001uF	50V	B	GRM39B102K50PT	K22174821		1-	B	c1
C 5162	CHIP CAP.	0.001uF	50V	B	GRM39B102K50PT	K22174821		1-	B	a2
C 5163	CHIP CAP.	0.001uF	50V	B	GRM39B102K50PT	K22174821		1-	B	a3

REF.	DESCRIPTION	VALUE	V/W	TOL.	MFR'S DESIG	VXSTD P/N	VERS.	LOT.	SIDE	LAY ADR
C 5164	CHIP CAP.	0.01uF	25V	B	GRM39B103K25PT	K22144803		1-	B	d3
C 5165	CHIP CAP.	0.01uF	25V	B	GRM39B103K25PT	K22144803		1-	B	b2
C 5166	CHIP CAP.	0.01uF	25V	B	GRM39B103K25PT	K22144803		1-	B	b2
C 5167	CHIP CAP.	0.001uF	50V	B	GRM39B102K50PT	K22174821		1-	B	b2
C 5168	CHIP CAP.	0.001uF	50V	B	GRM39B102K50PT	K22174821		1		
C 5169	CHIP CAP.	39pF	200V	CH	GRM40CH390J200PT	K22230223		1	B	c2
C 5169	CHIP CAP.	22pF	200V	CH	GRM40CH220J200PT	K22230220		2-	B	c2
C 5170	CHIP CAP.	22pF	200V	CH	GRM40CH220J200PT	K22230220		1-	B	c1
C 5172	CHIP CAP.	6pF	200V	CH	GRM40CH060D200PT	K22230212		1	B	b3
C 5172	CHIP CAP.	7pF	200V	CH	GRM40CH070D200PT	K22230213		2-	B	b3
C 5173	CHIP CAP.	6pF	200V	CH	GRM40CH060D200PT	K22230212		1	B	b3
C 5173	CHIP CAP.	7pF	200V	CH	GRM40CH070D200PT	K22230213		2-	B	b3
C 5174	CHIP CAP.	22pF	200V	CH	GRM40CH220J200PT	K22230220		2-	B	c2
C 5175	CHIP CAP.	22pF	200V	CH	GRM40CH220J200PT	K22230220		2-	B	c2
C 5176	CHIP CAP.	0.001uF	50V	B	GRM39B102K50PT	K22174821		2-	B	d3
C 5177	CHIP CAP.	0.001uF	50V	B	GRM39B102K50PT	K22174821		2-	B	d3
C 5178	CHIP CAP.	0.001uF	50V	B	GRM39B102K50PT	K22174821		2-	B	c3
C 5179	CHIP CAP.	0.001uF	50V	B	GRM39B102K50PT	K22174821		2-	B	c3
C 5180	CHIP CAP.	0.001uF	50V	B	GRM39B102K50PT	K22174821		2-	A	F3
C 5181	CHIP CAP.	0.001uF	50V	B	GRM39B102K50PT	K22174821		2-	A	E3
C 5182	CHIP CAP.	0.001uF	50V	B	GRM39B102K50PT	K22174821		2-	B	c2
C 5183	CHIP CAP.	0.001uF	50V	B	GRM40B102M50PT	K22170805		2-	A	E3
C 5185	CHIP CAP.	0.001uF	50V	B	GRM39B102K50PT	K22174821		2-	B	b2
D 5001	DIODE				MA716-(TX)	G2070342		1-	B	b1
D 5002	DIODE				MA716-(TX)	G2070342		1-	B	a2
D 5003	DIODE				MA716-(TX)	G2070342		1-	B	c1
D 5004	DIODE				MA716-(TX)	G2070342		1-	B	a3
D 5005	DIODE				1SS270	G2090408		1	A	E1
D 5005	DIODE				1SS106	G2090244		2-	A	E1
D 5006	DIODE				UM9415	G2090425		1-	A	F2
D 5007	DIODE				UM9415	G2090425		1	A	H1
D 5007	DIODE				UM9401	G2090414		2-	A	H1
D 5008	DIODE				1SS106	G2090244		1-	A	E1
D 5009	DIODE				UM9401F/TR	G2070516		1-	B	b2
D 5010	DIODE				UM9401F/TR	G2070516		1-	B	a1
D 5011	DIODE				DAN202U T106	G2070162		1-	B	a2
D 5014	DIODE				DA227-TR	G2070292		1	B	d3
D 5014	DIODE				RB480K-TL	G2070710		2-	B	d3
D 5016	DIODE				DAP202U T106	G2070160		1-	B	c3
D 5017	DIODE				DAP202U T106	G2070160		1-	A	E3
D 5018	DIODE				DAN202U T106	G2070162		1-	B	d3
D 5021	DIODE				DAP236U T106	G2070592		1-	B	b2
D 5022	DIODE				UM9401F/TR	G2070516		2-	B	b2
D 5023	DIODE				UM9401F/TR	G2070516		2-	B	b3
J 5013	CONNECTOR				12FMZ-BT	P1090901		1-	A	E3
J 5014	CONNECTOR				TMP-J01X-A2	P1090255		2-	A	F3
J 5015	CONNECTOR				TMP-J01X-A2	P1090255		2-	A	D3
JP5001	WIRE ASSY				YEL 120 TMP/TMP(B1)	T9318067		1	A	D2
JP5001	WIRE ASSY				YEL 100 TMP(B1)/TMP	T9318094		2-	A	D2
JP5002	WIRE ASSY				RED 170 TMP/TMP	T9317958		1		
JP5003	WIRE ASSY				RED 200 TMP/TMP	T9317994		1		
JP5004	WIRE ASSY				BLU 120 TMP/TMP(B1)	T9318068		1	A	G3
JP5004	WIRE ASSY				BLU 85 TMP(B1)/TMP	T9318093		2-	A	G3
JP5005	WIRE ASSY				60 7/7	T9318080		1		
JP5005	WIRE ASSY				80 7/7	T9318111		2-		
L 5001	COIL A1				1.5T4.0D0.6UEW R	L0021822A		1-	A	F3
L 5002	COIL A1				4.5T4.0D0.6UEW R	L0021825A		1-	A	F3
L 5003	COIL A1				1.5T4.0D0.6UEW R	L0021822A		1-	A	F3
L 5004	COIL A1				3.5T3.5D0.6UEW R	L0021818A		1-	A	F2
L 5005	COIL A1				1.5T4.0D0.6UEW R	L0021822A		1-	A	G3
L 5006	TOROIDAL COIL	4.5uH			4.50U T44-2	L0022560		1-	A	B2
L 5007	TOROIDAL COIL	0.114uH			0.114U T44-10	L0022569		1-	A	C2
L 5008	COIL B1				8.0T8.5D0.9UEW R	L0021855		1-	A	B2
L 5009	COIL B1				6.0T8.0D0.8UEW L	L0022570		1-	A	C3
L 5010	TOROIDAL COIL	2.05uH			2.05U T44-2	L0022562		1-	A	A2
L 5011	TOROIDAL COIL	1.32uH			1.32U T44-2	L0022564		1-	A	A1
L 5011	TOROIDAL COIL	1.32uH			1.32U T44-2	L0022564A		12-	A	A1
L 5012	TOROIDAL COIL	0.558uH			0.558U T44-10	L0022566		1-	A	C2

LPF Unit

REF.	DESCRIPTION	VALUE	V/W	TOL.	MFR'S DESIG	VXSTD P/N	VERS.	LOT.	SIDE	LAY ADR
L 5012	TOROIDAL COIL	0.558uH			0.558U T44-10	L0022566A		12-	A	C2
L 5013	COIL A1				3.5T4.0D0.6UEW R	L0021824A		1-	A	F2
L 5013	COIL A1				4.5T4.0D0.6UEW R	L0021825A		3-	A	F2
L 5014	COIL A1				1.5T4.0D0.6UEW R	L0021822A		1-	A	G3
L 5015	TOROIDAL COIL	0.146uH			0.146U T44-10	L0022568		1-	A	D2
L 5016	COIL B1				9.0T8.5D0.9UEW R	L0021856		1-	A	A2
L 5017	COIL B1				7.0T8.5D0.9UEW R	L0021858		1-	A	B2
L 5018	TOROIDAL COIL	1.57uH			1.57U T44-2	L0022563		1-	A	B2
L 5019	TOROIDAL COIL	1.11uH			1.11U T44-2	L0022565		1-	A	A2
L 5019	TOROIDAL COIL	1.11uH			1.11U T44-2	L0022565A		13-	A	A2
L 5020	TOROIDAL COIL	0.4uH			0.400U T44-10	L0022567		1-	A	C2
L 5021	TOROIDAL COIL	3.6uH			3.60U T44-2	L0022561		1-	A	B2
L 5022	TOROIDAL COIL	0.146uH			0.146U T44-10	L0022568		1-	A	D2
L 5023	M.RFC	10uH			LAL02NA100K	L1190295		2	A	F1
L 5023	M.RFC	10uH			LAP02KR100K	L1190344		3-	A	F1
L 5024	M.RFC	2.2uH			LAP02KR2R2M	L1190346		1-	A	G2
L 5025	COIL WIDE-TRANS.				1-1 T25-12	L0021631		1-	A	F1
L 5026	M.RFC	10uH			LAL02NA100K	L1190295		2	A	F1
L 5026	M.RFC	10uH			LAP02KR100K	L1190344		3-	A	F1
L 5027	M.RFC	2.2uH			LAP02KR2R2M	L1190346		1-	A	G3
L 5028	M.RFC	1mH			LAL04SK102K	L1190140		1-	A	D2
L 5029	COIL A1				8.5T3.0D0.5UEW R	L0020724A		1	A	F2
L 5029	M.RFC	4.7uH			LAL04NA4R7K	L1190095		2-	A	F2
L 5030	COIL A1				6.5T2.0D0.5UEW R	L0021803A		1-	A	H2
L 5031	TOROIDAL COIL	110uH			110U RI9.3-4.8-5	L0021859		1-	A	E1
L 5032	COIL A1				4.5T3.0D0.6UEW R	L0021813A		1-	A	F2
L 5033	COIL A1				1.5T3.5D0.6UEW R	L0021359A		1-	A	H1
L 5034	M.RFC	1mH			LAL04SK102K	L1190140		1-	A	E2
L 5035	M.RFC	120uH			RCH-875 121K	L1190396		1-	A	E1
L 5036	M.RFC	22uH			RCR-875D 220L	L1190397		1-	A	E2
L 5037	COIL A1				3.5T4.0D0.6UEW R	L0021824A		1-	A	F3
L 5038	COIL A1				1.5T4.0D0.6UEW R	L0021822A		1-	A	F3
L 5039	COIL A1				3.5T4.0D0.6UEW R	L0021824A		1-	A	F2
L 5040	COIL A1				3.5T4.0D0.6UEW R	L0021824A		1-	A	F2
L 5042	M.RFC	1uH			LK1608 1R0K-T	L1690687		2-	B	b2
L 5043	M.RFC	0.22uH			LK1608 R22K-T	L1690410		2-	B	b2
L 5044	M.RFC	10uH			LAL02NA100K	L1190295		6-		
L05023	M.RFC	10uH			LAL02NA100K	L1190295		1		
L05026	M.RFC	10uH			LAL02NA100K	L1190295		1		
Q 5001	IC				TD62783F TP1	G1091620		1-	A	E2
Q 5002	IC				MC14028BFL	G1090998		1-	B	c2
Q 5003	TRANSISTOR				FMC5A T148	G3070185		1-	B	c3
Q 5004	TRANSISTOR				FMC5A T148	G3070185		1-	B	c2
Q 5005	TRANSISTOR				2SC4047-TA	G3340477		1-	B	d3
Q 5006	TRANSISTOR				2SC4047-TA	G3340477		1-	B	b2
Q 5007	TRANSISTOR				2SC4047-TA	G3340477		1-	B	b2
R 5001	CHIP RES.	120	1/16W	5%	RMC1/16 121JATP	J24185121		1-	B	a2
R 5002	CHIP RES.	470	1/4W	5%	RMC1/4 471JATP	J24245471		1-	B	b1
R 5003	CHIP RES.	220	1/4W	5%	RMC1/4 221JATP	J24245221		1-	B	b1
R 5004	CHIP RES.	1k	1/16W	5%	RMC1/16 102JATP	J24185102		1-	B	d2
R 5005	METAL FILM RES.	27	1W	5%	ERG-1SJ270 27	J22305270		1-	A	E1
R 5006	CHIP RES.	1k	1/16W	5%	RMC1/16 102JATP	J24185102		1		
R 5008	METAL FILM RES.	27	1W	5%	ERG-1SJ270 27	J22305270		1-	A	E2
R 5011	CHIP RES.	1k	1/16W	5%	RMC1/16 102JATP	J24185102		1		
R 5012	CHIP RES.	1k	1/16W	5%	RMC1/16 102JATP	J24185102		1-	B	c2
R 5016	CHIP RES.	120	1W	5%	RMC1 121JTE	J24305121		1-	A	F2
R 5017	CHIP RES.	120	1W	5%	RMC1 121JTE	J24305121		1	B	a2
R 5017	CHIP RES.	180	1W	5%	RMC1 181JTE	J24305181		2-	B	a2
R 5018	CHIP RES.	47	1/4W	5%	RMC1/4 470JATP	J24245470		1-	B	a3
R 5021	CHIP RES.	1k	1/16W	5%	RMC1/16 102JATP	J24185102		1		
R 5022	CHIP RES.	1k	1/16W	5%	RMC1/16 102JATP	J24185102		1		
R 5023	CHIP RES.	10k	1/16W	5%	RMC1/16 103JATP	J24185103		1-	B	b2
R 5024	CHIP RES.	10k	1/16W	5%	RMC1/16 103JATP	J24185103		1-	B	b2
R 5025	CHIP RES.	4.7k	1/16W	5%	RMC1/16 472JATP	J24185472		2-3		
R 5026	CHIP RES.	1k	1/10W	5%	RMC1/10T 102J	J24205102		2-	B	b2
R 5027	CHIP RES.	1k	1/10W	5%	RMC1/10T 102J	J24205102		2-	A	F1
R 5028	CHIP RES.	3.3k	1/16W	5%	RMC1/16 332JATP	J24185332		2-	A	F1
R 5029	CHIP RES.	3.3k	1/16W	5%	RMC1/16 332JATP	J24185332		2-	A	F1

REF.	DESCRIPTION	VALUE	V/W	TOL.	MFR'S DESIG	VXSTD P/N	VERS.	LOT.	SIDE	LAY ADR
R 5030	CHIP RES.	0	1/16W	5%	RMC1/16 000JATP	J24185000		2-	B	a1
R 5031	CARBON FILM RES.	10k	1/6W	5%	RD16TPJ103 10K	J07225103		4-	B	c3
R 5031	CHIP RES.	10k	1/16W	5%	RMC1/16 103JATP	J24185103		9-	B	c3
R 5032	CARBON FILM RES.	10k	1/6W	5%	RD16TPJ103 10K	J07225103		4-	B	c3
R 5032	CHIP RES.	10k	1/16W	5%	RMC1/16 103JATP	J24185103		9-	B	c3
R 5035	CHIP RES.	0	1/16W	5%	RMC1/16 000JATP	J24185000		9-	A	F3
R 5036	CHIP RES.	0	1/16W	5%	RMC1/16 000JATP	J24185000		9-	B	c3
RL5001	RELAY		DC12V		ATK103 DC12V	M1190151		1-	A	D3
RL5001	RELAY		DC12V		AG201344 DC12V	M1190124		9-	A	D3
RL5002	RELAY		DC12V		AHY123 DC12V	M1190149		1-	A	B3
RL5003	RELAY		DC12V		AHY123 DC12V	M1190149		1-	A	A3
RL5004	RELAY		DC12V		AHY123 DC12V	M1190149		1-	A	A3
RL5005	RELAY		DC12V		AHY123 DC12V	M1190149		1-	A	C3
RL5006	RELAY		DC12V		AHY123 DC12V	M1190149		1-	A	B3
RL5007	RELAY		DC12V		AHY123 DC12V	M1190149		1-	A	C3
RL5008	RELAY		DC12V		AG201344 DC12V	M1190124		1-	A	C3
RL5009	RELAY		DC12V		AHY123 DC12V	M1190149		1-	A	C1
RL5010	RELAY		DC12V		AHY123 DC12V	M1190149		1-	A	B1
RL5011	RELAY		DC12V		AHY123 DC12V	M1190149		1-	A	A1
RL5012	RELAY		DC12V		AHY123 DC12V	M1190149		1-	A	C1
RL5013	RELAY		DC12V		AHY123 DC12V	M1190149		1-	A	B1
RL5014	RELAY		DC12V		AHY123 DC12V	M1190149		1-	A	B1
RL5015	RELAY		DC12V		AG201344 DC12V	M1190124		1-	A	D1
RL5016	RELAY		DC12V		ARG341 DC12V	M1190150		1-	A	G2
TC5001	TRIMMER CAP.	6pF			TZBX4Z060BC110 6PF	K91000197		1-	A	F1
TC5002	TRIMMER CAP.	20pF			ECV1ZW20X53T 20PF	K91000029		1-	A	D1
TC5003	TRIMMER CAP.	6pF			TZBX4Z060BC110 6PF	K91000197		1-	A	G3
	LEAD CLAMP				L=38	S5000057		4-		
	TOOTHED LOCK WASHER				OW2.6	U72002001		16-		

LPF Unit

Note:

Circuit Diagram

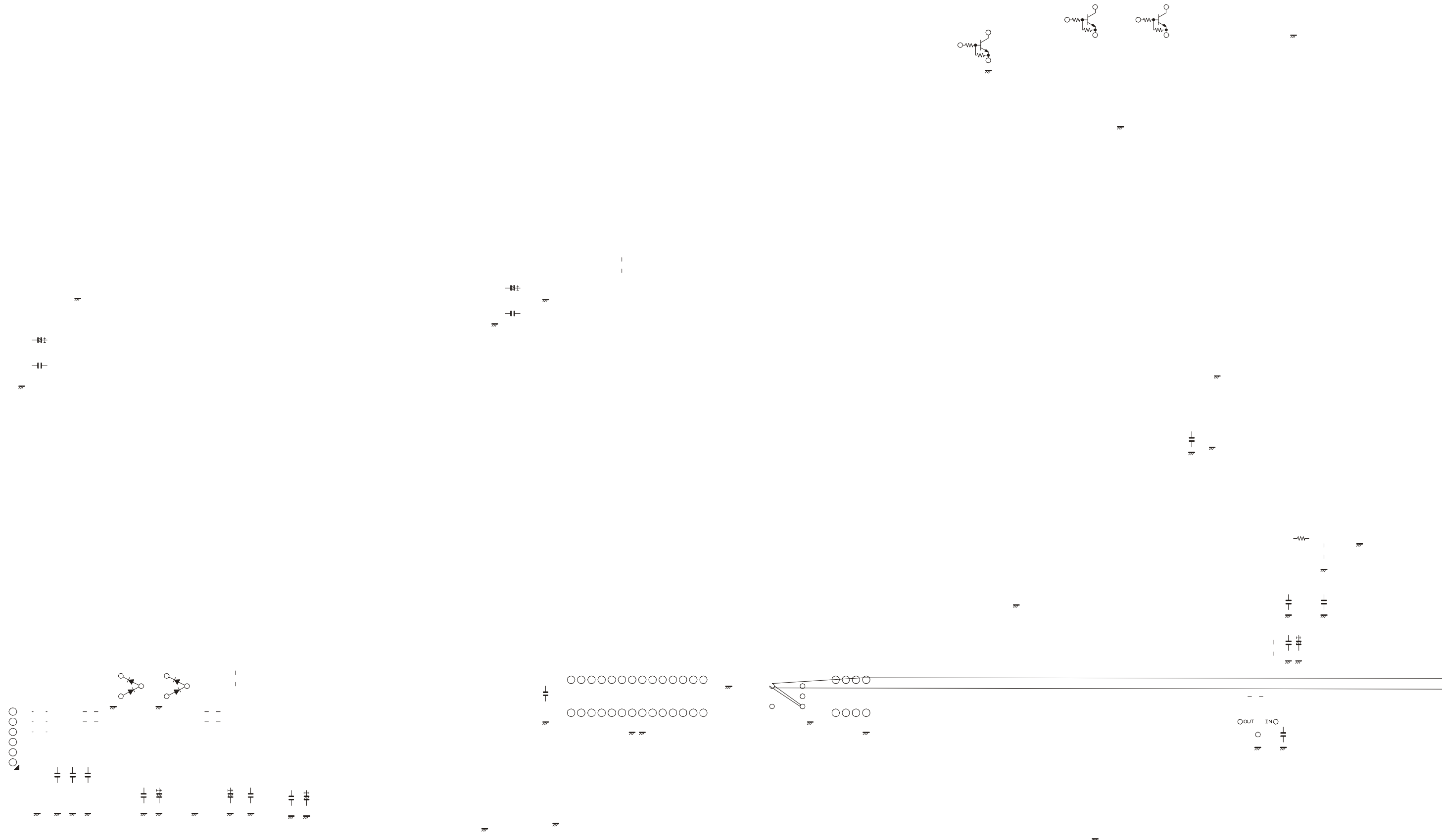





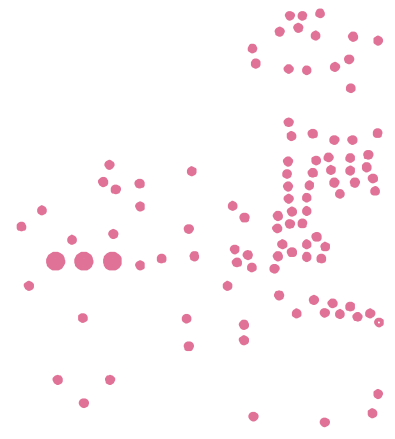

Parts List

REF.	DESCRIPTION	VALUE	V/W	TOL.	MFR'S DESIG	VXSTD P/N	VERS.	LOT.	SIDE	LAY ADR
*** DISPLAY-UNIT ***										
	PCB with Components					CS0559004	TYP A2			
	PCB with Components					CS0559005	TYP A1			
	PCB with Components					CS0559006	TYP A3			
	PCB with Components					CS0559007	TYP B1			
	PCB with Components					CS0559008	TYP B2			
	PCB with Components					CS0559009	TYP B3			
	PCB with Components					CS0559010	TYP C1			
	PCB with Components					CS0559011	TYP C2			
	PCB with Components					CS0559012	TYP C3			
	PCB with Components					CS0559013	TYP D1			
	PCB with Components					CS0559014	TYP D2			
	PCB with Components					CS0559015	TYP H1			
	PCB with Components					CS0559016	TYP H2			
	Printed Circuit Board					FR002340C				
	Printed Circuit Board					FR002340D		2-		
								34-		
C 6001	CHIP CAP.	0.01uF	25V	B	GRM39B103K25PT	K22144803		1-	B	f1
C 6002	CHIP TA.CAP.	3.3uF	10V		TEMSVA1A335M-8R	K78100015		1-	B	f1
C 6003	CHIP CAP.	10pF	50V	CH	GRM39CH100D50PT	K22174211		1-	B	c2
C 6004	CHIP CAP.	10pF	50V	CH	GRM39CH100D50PT	K22174211		1-	B	c2
C 6005	CHIP CAP.	0.01uF	25V	B	GRM39B103K25PT	K22144803		1-	B	c2
C 6006	CHIP CAP.	0.01uF	25V	B	GRM39B103K25PT	K22144803		1-	B	c1
C 6007	CHIP CAP.	0.001uF	50V	B	GRM39B102K50PT	K22174821		1		
C 6008	CHIP CAP.	0.01uF	25V	B	GRM39B103K25PT	K22144803		1-	B	c1
C 6009	CHIP TA.CAP.	4.7uF	10V		TEMSVA1A475M-8R	K78100022		1-	B	c1
C 6010	CHIP TA.CAP.	4.7uF	10V		TEMSVA1A475M-8R	K78100022		1-	B	c1
C 6011	CHIP CAP.	0.01uF	25V	B	GRM39B103K25PT	K22144803		1-	B	c1
C 6012	CHIP TA.CAP.	10uF	10V		TEMSVA1A106M-8R	K78100028		1-	B	c1
C 6013	CHIP CAP.	0.01uF	25V	B	GRM39B103K25PT	K22144803		1-	B	g1
C 6014	CHIP TA.CAP.	3.3uF	10V		TEMSVA1A335M-8R	K78100015		1-	B	g1
C 6015	CHIP CAP.	0.01uF	50V	B	GRM40B103M50PT	K22170817		1-	A	F2
C 6016	CHIP CAP.	0.01uF	25V	B	GRM39B103K25PT	K22144803		1-	B	e3
C 6017	CHIP CAP.	0.01uF	25V	B	GRM39B103K25PT	K22144803		1-	B	c1
C 6018	CHIP CAP.	0.01uF	25V	B	GRM39B103K25PT	K22144803		1-	B	d1
C 6019	CHIP CAP.	33pF	50V	CH	GRM39CH330J50PT	K22174223		1-	B	d1
C 6020	CHIP CAP.	0.01uF	25V	B	GRM39B103K25PT	K22144803		1-	B	d1
C 6021	CHIP TA.CAP.	3.3uF	10V		TEMSVA1A335M-8R	K78100015		1-	B	d1
C 6022	CHIP CAP.	33pF	50V	CH	GRM39CH330J50PT	K22174223		1-	B	d1
C 6023	CHIP CAP.	0.01uF	25V	B	GRM39B103K25PT	K22144803		2-	B	h2
C 6024	CHIP CAP.	0.01uF	25V	B	GRM39B103K25PT	K22144803		2-	B	h2
C 6025	AL.ELECTRO.CAP.	220uF	10V		SMG1AVB221M 220UF	K40109027		2-	B	c1
C 6026	CHIP TA.CAP.	10uF	10V		TEMSVA1A106M-8R	K78100028		16-		
CO6001	CERAMIC OSC	5MHz			CSAC5.00MGC-TC	H7901100		1-	B	d1
D 6001	DIODE				1SS302 TE85R	G2070088		1-	B	c2
D 6002	DIODE				1SS302 TE85R	G2070088		1-	B	c2
D 6003	LED				NSPW310AS	G2090705		1-	A	E1
D 6003	LED				NSPW310BS	G2090747		9-	A	E1
D 6004	LED				NSPW310AS	G2090705		1-	A	E2
D 6004	LED				NSPW310BS	G2090747		9-	A	E2
D 6005	LED				VRPG3312X	G2090557		1-	A	G1
D 6006	LED				NSPW310AS	G2090705		1-	A	E2
D 6006	LED				NSPW310BS	G2090747		9-	A	E2
DS6001	LCD				DLC-8305GNGT	G6090130		1	A	C1
DS6001	LCD				DLC-8305G2GT	G6090130A		2-	A	C1
DS6001	LCD				DLC-8318G2GT	G6090130B		5-	A	C1
J 6001	CONNECTOR				00 6200 506 130 000	P1090981		1-	B	c2
J 6002	CONNECTOR				SB20-04WL	P0090826		1-	B	c2
J 6003	CONNECTOR				SB20-06WL	P0090845		1		
L 6001	M.RFC	10uH			LK2125 100K-T	L1690331		1-	B	c2
L 6002	M.RFC	10uH			LK2125 100K-T	L1690331		1-	B	c2
L 6003	M.RFC	10uH			LK2125 100K-T	L1690331		1-	B	c2
L 6004	M.RFC	10uH			LK2125 100K-T	L1690331		1		
L 6005	M.RFC	10uH			LK2125 100K-T	L1690331		1		
Q 6001	IC				NJU6451AFG1	G1092751		1-	B	e2
Q 6002	IC				NJM78L05UA TE1	G1091325		1-	B	c1
Q 6002	IC				UPC29L05J	G1093112		5-	B	c1
Q 6002	IC				UPC29L05J	G1093112		10-	B	c1
Q 6003	IC				FQ7927	G1091854		1-	B	d2

Display Unit

REF.	DESCRIPTION	VALUE	V/W	TOL.	MFR'S DESIG	VXSTD P/N	VERS.	LOT.	SIDE	LAY ADR
Q 6004	IC				NJU6450AFG1	G1092750		1-	B	g2
Q 6005	TRANSISTOR				2SC3444-T11-1E	G3334448E		1-	A	F1
Q 6006	IC				TC7S08FU TE85R	G1091528		1-	B	d1
Q 6007	IC				TC7W08FU TE12L	G1092264		1-	B	d1
Q 6008	TRANSISTOR				2SC4047-TA	G3340477		1-	B	h2
Q 6009	TRANSISTOR				2SC4047-TA	G3340477		1-	B	a1
Q 6010	TRANSISTOR				2SC4047-TA	G3340477		1-	B	a1
Q 6011	TRANSISTOR				2SC4047-TA	G3340477		1-	A	F2
Q 6012	IC				UPD78P054GK-BE9	×		1-	B	d1
Q 6012	IC				UPD78054GK-566-BE9	×		5-	B	d1
Q 6012	IC				UPD780054GK-A12-9EU	×		35-	B	d1
Q 6013	IC				M51951AML-600C	G1091131		1-	B	d1
R 6001	CHIP RES.	2.2k	1/16W	5%	RMC1/16 222JATP	J24185222		1-	B	c2
R 6002	CHIP RES.	2.2k	1/16W	5%	RMC1/16 222JATP	J24185222		1-	B	c2
R 6003	CHIP RES.	1k	1/16W	5%	RMC1/16 102JATP	J24185102		1-	B	c2
R 6004	CHIP RES.	1k	1/16W	5%	RMC1/16 102JATP	J24185102		1-	B	c2
R 6005	CHIP RES.	10k	1/16W	5%	RMC1/16 103JATP	J24185103		1-	B	c2
R 6006	CHIP RES.	1k	1/16W	5%	RMC1/16 102JATP	J24185102		1	B	g1
R 6006	CHIP RES.	4.7k	1/16W	5%	RMC1/16 472JATP	J24185472		2-	B	g1
R 6007	CHIP RES.	1k	1/16W	5%	RMC1/16 102JATP	J24185102		1	B	g1
R 6007	CHIP RES.	4.7k	1/16W	5%	RMC1/16 472JATP	J24185472		2-	B	g1
R 6008	CHIP RES.	1k	1/16W	5%	RMC1/16 102JATP	J24185102		1	B	g1
R 6008	CHIP RES.	4.7k	1/16W	5%	RMC1/16 472JATP	J24185472		2-	B	g1
R 6009	CHIP RES.	1k	1/16W	5%	RMC1/16 102JATP	J24185102		1	B	f1
R 6009	CHIP RES.	4.7k	1/16W	5%	RMC1/16 472JATP	J24185472		2-	B	f1
R 6010	CHIP RES.	1k	1/16W	5%	RMC1/16 102JATP	J24185102		1	B	f1
R 6010	CHIP RES.	4.7k	1/16W	5%	RMC1/16 472JATP	J24185472		2-	B	f1
R 6011	CHIP RES.	470	1/10W	5%	RMC1/10T 471J	J24205471		1-	B	b1
R 6012	CHIP RES.	470	1/10W	5%	RMC1/10T 471J	J24205471		1-	B	b1
R 6013	CHIP RES.	470	1/10W	5%	RMC1/10T 471J	J24205471		1-	B	b1
R 6014	CHIP RES.	470	1/10W	5%	RMC1/10T 471J	J24205471		1-	B	b1
R 6015	CHIP RES.	1M	1/16W	5%	RMC1/16 105JATP	J24185105		1-	B	g1
R 6016	CHIP RES.	10k	1/10W	5%	RMC1/10T 103J	J24205103		1-	A	G1
R 6017	CHIP RES.	2.2k	1/10W	5%	RMC1/10T 222J	J24205222		1-	A	G1
R 6018	CHIP RES.	1k	1/10W	5%	RMC1/10T 102J	J24205102		1-	B	h2
R 6019	CHIP RES.	1k	1/10W	5%	RMC1/10T 102J	J24205102		1-	B	h2
R 6020	CHIP RES.	1k	1/10W	5%	RMC1/10T 102J	J24205102		1-	B	h2
R 6021	CHIP RES.	1k	1/10W	5%	RMC1/10T 102J	J24205102		1-	B	h2
R 6022	CHIP RES.	1k	1/10W	5%	RMC1/10T 102J	J24205102		1-	B	a1
R 6023	CHIP RES.	1k	1/10W	5%	RMC1/10T 102J	J24205102		1-	B	a1
R 6024	CHIP RES.	1k	1/10W	5%	RMC1/10T 102J	J24205102		1-	B	a1
R 6025	CHIP RES.	1k	1/10W	5%	RMC1/10T 102J	J24205102		1-	B	a1
R 6026	CHIP RES.	1k	1/10W	5%	RMC1/10T 102J	J24205102		1-	A	F2
R 6027	CHIP RES.	1k	1/10W	5%	RMC1/10T 102J	J24205102		1-	A	F2
R 6028	CHIP RES.	1k	1/10W	5%	RMC1/10T 102J	J24205102		1-	A	F2
R 6029	CHIP RES.	1k	1/10W	5%	RMC1/10T 102J	J24205102		1-	A	F2
R 6030	CHIP RES.	560	1/16W	5%	RMC1/16 561JATP	J24185561		1-	B	d1
R 6031	CHIP RES.	10	1/16W	5%	RMC1/16 100JATP	J24185100		1-	B	d1
R 6032	CHIP RES.	4.7k	1/16W	5%	RMC1/16 472JATP	J24185472		1-4	B	c1
R 6032	CHIP RES.	4.7k	1/16W	5%	RMC1/16 472JATP	J24185472		5-	B	c1
R 6033	CHIP RES.	470	1/10W	5%	RMC1/10T 471J	J24205471		1-	B	b1
R 6034	CHIP RES.	470	1/10W	5%	RMC1/10T 471J	J24205471		1-	B	a1
R 6035	CHIP RES.	0	1/10W	5%	RMC1/10T 000J	J24205000		1	B	a1
R 6035	CHIP RES.	0	1/10W	5%	RMC1/10T 000J	J24205000	VERSION A1	2-	B	a1
R 6035	CHIP RES.	0	1/10W	5%	RMC1/10T 000J	J24205000	VERSION B1	2-	B	a1
R 6035	CHIP RES.	0	1/10W	5%	RMC1/10T 000J	J24205000	VERSION C1	2-	B	a1
R 6035	CHIP RES.	0	1/10W	5%	RMC1/10T 000J	J24205000	VERSION D1	2-	B	a1
R 6035	CHIP RES.	0	1/10W	5%	RMC1/10T 000J	J24205000	VERSION H1	2-	B	a1
R 6036	CHIP RES.	0	1/10W	5%	RMC1/10T 000J	J24205000		1	B	a1
R 6036	CHIP RES.	0	1/10W	5%	RMC1/10T 000J	J24205000	VERSION A1	2-	B	a1
R 6036	CHIP RES.	0	1/10W	5%	RMC1/10T 000J	J24205000	VERSION A2	2-	B	a1
R 6036	CHIP RES.	0	1/10W	5%	RMC1/10T 000J	J24205000	VERSION B1	2-	B	a1
R 6036	CHIP RES.	0	1/10W	5%	RMC1/10T 000J	J24205000	VERSION B2	2-	B	a1
R 6036	CHIP RES.	0	1/10W	5%	RMC1/10T 000J	J24205000	VERSION C1	2-	B	a1
R 6036	CHIP RES.	0	1/10W	5%	RMC1/10T 000J	J24205000	VERSION C2	2-	B	a1
R 6036	CHIP RES.	0	1/10W	5%	RMC1/10T 000J	J24205000	VERSION D1	2-	B	a1
R 6036	CHIP RES.	0	1/10W	5%	RMC1/10T 000J	J24205000	VERSION D2	2-	B	a1
R 6036	CHIP RES.	0	1/10W	5%	RMC1/10T 000J	J24205000	VERSION H1	2-	B	a1

Display Unit

REF.	DESCRIPTION	VALUE	V/W	TOL.	MFR'S DESIG	VXSTD P/N	VERS.	LOT.	SIDE	LAY ADR	
R 6036	CHIP RES.	0	1/10W	5%	RMC1/10T 000J	J24205000	VERSION H2	2-	B	a1	
R 6037	CHIP RES.	0	1/10W	5%	RMC1/10T 000J	J24205000		1	B	a1	
R 6037	CHIP RES.	0	1/10W	5%	RMC1/10T 000J	J24205000		2-	B	a1	
R 6038	CHIP RES.	0	1/10W	5%	RMC1/10T 000J	J24205000		1	B	a1	
R 6038	CHIP RES.	0	1/10W	5%	RMC1/10T 000J	J24205000		2-	B	a1	
R 6039	CHIP RES.	4.7k	1/16W	5%	RMC1/16 472JATP	J24185472		1-	B	d2	
R 6040	CHIP RES.	4.7k	1/16W	5%	RMC1/16 472JATP	J24185472		1-	B	e2	
R 6041	CHIP RES.	4.7k	1/16W	5%	RMC1/16 472JATP	J24185472		1-	B	d2	
R 6042	CHIP RES.	4.7k	1/16W	5%	RMC1/16 472JATP	J24185472		1	B	d2	
R 6042	CHIP RES.	4.7k	1/16W	5%	RMC1/16 472JATP	J24185472		2-	B	d2	
R 6043	CHIP RES.	10k	1/16W	5%	RMC1/16 103JATP	J24185103		1-	B	g2	
R 6044	CHIP RES.	10k	1/16W	5%	RMC1/16 103JATP	J24185103		1-	B	g2	
R 6045	CHIP RES.	39	1/4W	5%	RMC1/4 390JATP	J24245390		2-	B	c1	
R 6045	CHIP RES.	0	1/4W	5%	RMC1/4 000JATP	J24245000		5-	B	c1	
R 6047	CHIP RES.	100	1/16W	5%	RMC1/16 101JATP	J24185101		2-	B	f1	
S 6001	TACT SWITCH				SKQHFJ	N5090087			1	A	A2
S 6001	TACT SWITCH				SKQHFC	N5090073			2-	A	A2
S 6002	TACT SWITCH				EVQPJX05M	N5090095		1-	A	B3	
S 6003	TACT SWITCH				EVQPJX05M	N5090095		1-	A	C3	
S 6004	TACT SWITCH				EVQPJX05M	N5090095		1-	A	D3	
S 6005	TACT SWITCH				EVQPJX05M	N5090095		1-	A	D3	
S 6006	TACT SWITCH				EVQPJX05M	N5090095		1-	A	F1	
S 6007	TACT SWITCH				EVQPJX05M	N5090095		1-	A	F1	
S 6008	TACT SWITCH				EVQPJX05M	N5090095		1-	A	F2	
S 6009	TACT SWITCH				EVQPJX05M	N5090095		1-	A	F2	
S 6010	TACT SWITCH				SKQHFJ	N5090087		1	A	E3	
S 6010	TACT SWITCH				SKQHFC	N5090087		2-	A	E3	
S 6011	TACT SWITCH				EVQPJX05M	N5090095		1-	A	H1	
S 6012	TACT SWITCH				EVQPJX05M	N5090095		1-	A	H1	
S 6013	TACT SWITCH				EVQPJX05M	N5090095		1-	A	H2	
S 6014	TACT SWITCH				EVQPJX05M	N5090095		1-	A	H2	
S 6015	TACT SWITCH				EVQPJX05M	N5090095		1-	A	H2	
S 6016	ROTARY ENCODER				EC11B15244	Q9000708		1-	A	A2	
TH6001	THERMISTOR				157-502-53002TP	G9090049		1-	B	c1	
TH6002	THERMISTOR				TBPS1R472K440H5Q	G9090066		2-	B	g1	
	LCD HOLDER				(LCD)	RA0068700		1-			
	LIGHT GUIDE					RA0068800		1-			
	REFLECTOR SHEET					RA0069000		1-			
	INTER CONNECTOR					RA0069100		1			
	INTER CONNECTOR					RA006910A		2-			
	LIGHT SHEET					RA0099600		1-			
	SPONGE RUBBER					RA0099700		1-			
	COLOR FILTER					RA0108200		2-			
	DIFFUSER SHEET				RA0108300		2-				

Display Unit

Note:

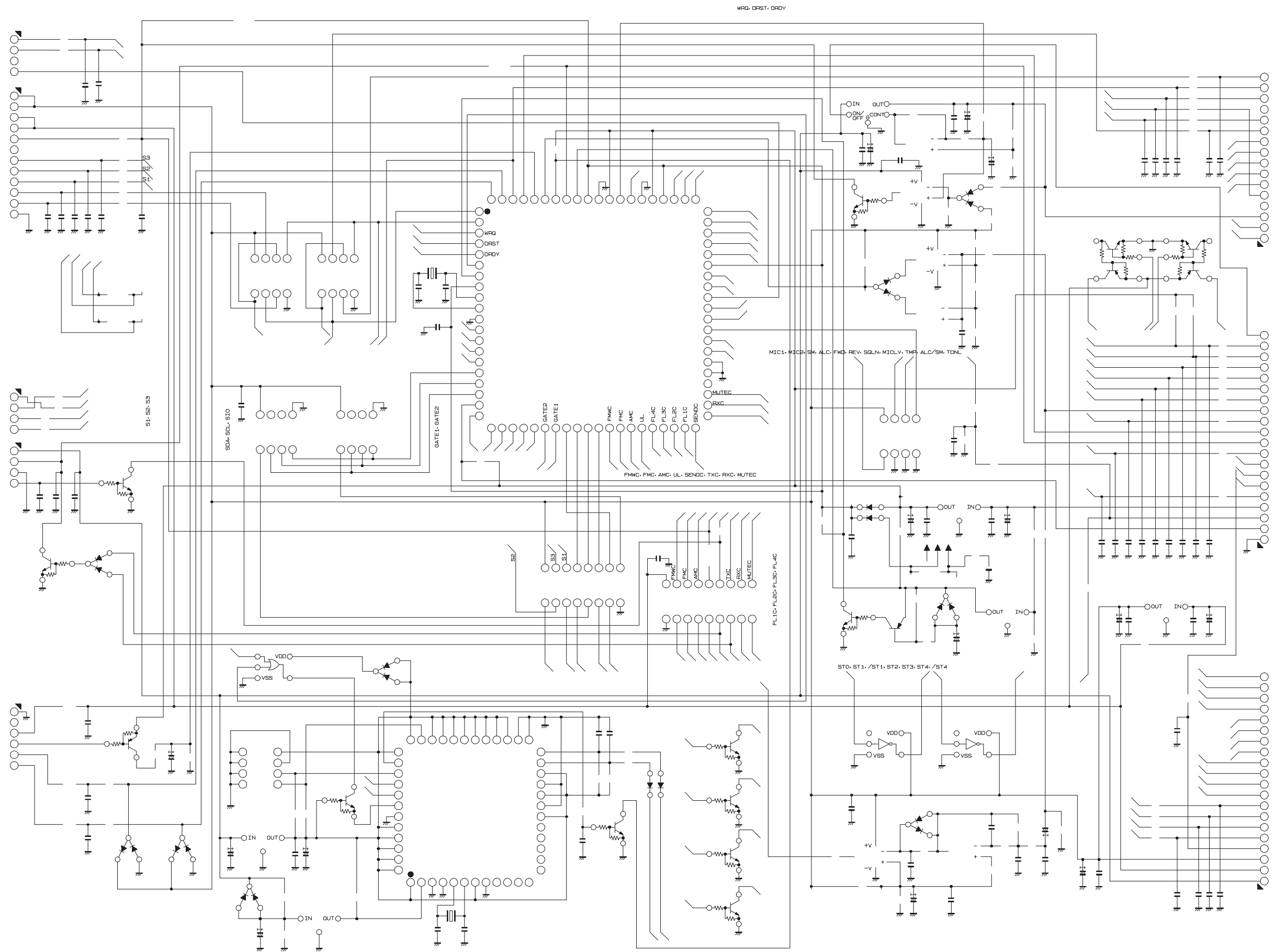

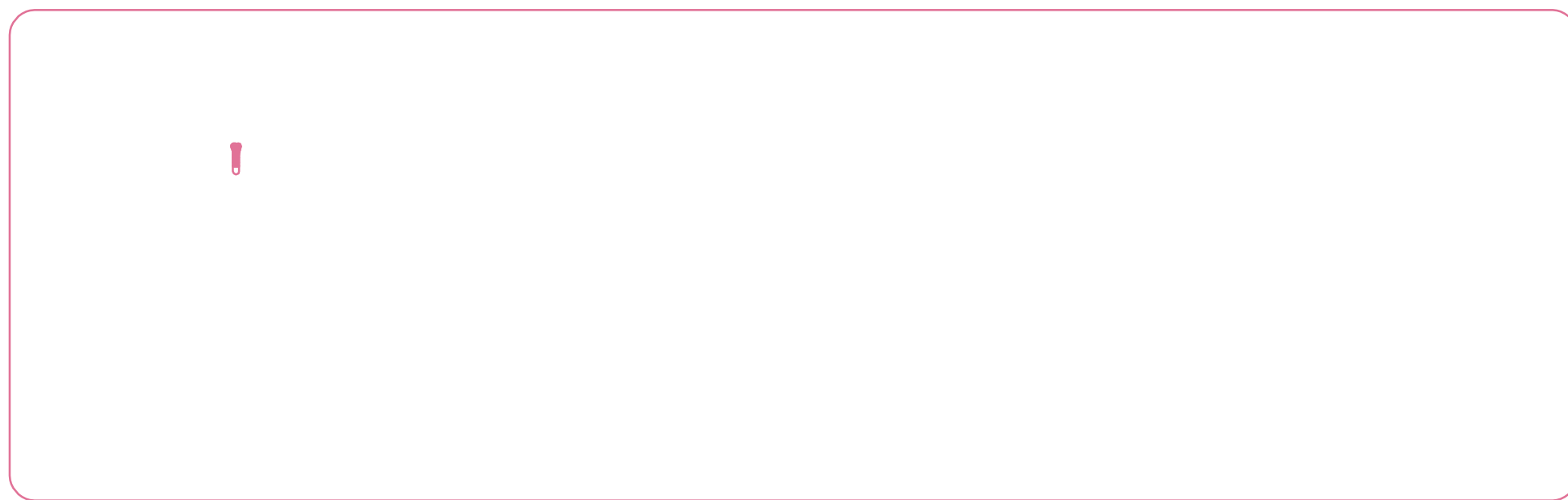



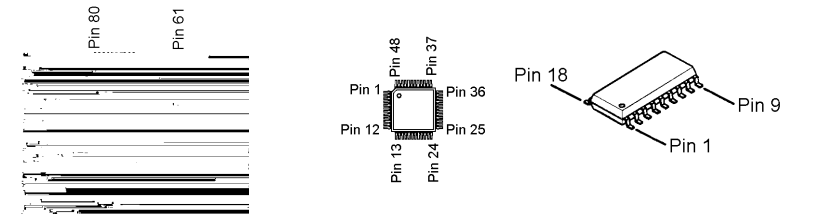

μPD78P4038GC (Low Power)
μPD784036GC (EXP, USA)
μPD784036GC (Q7013)
μPD784036GC (Q7018)
μPD784036GC (Q7013)
μPD784036GC (Q7013)

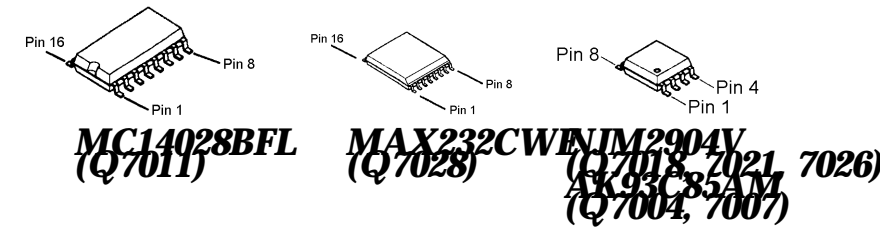

MC14028BFL (Q7011)
MAX232CW (Q7028)
MAX232CWM (Q7018, 7021, 7026)
MAX232CWM (Q7004, 7007)

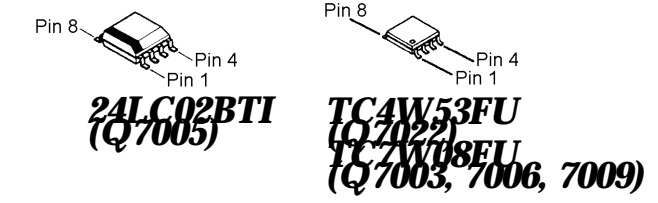

24LC02BTI (Q7005)
TC4W53FU (Q7022)
TC4W53FU (Q7003, 7006, 7009)

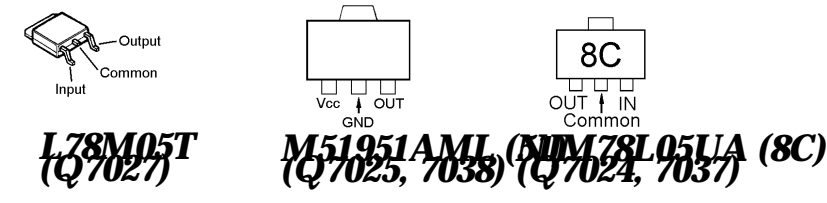

L78M05T (Q7027)
M51951AMI (Q7025, 7038)
51951AMI (Q7024, 7037)
8C (Q7024, 7037)



FMC5A (C5) (Q7029, 7030)
2SC4047 (ZV) (Q7001, 7002, 7012, 7014, 7015, 7016, 7017, 7020, 7036, 7039)

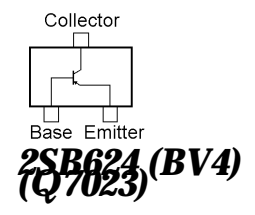

2SB62A (BV4) (Q7023)

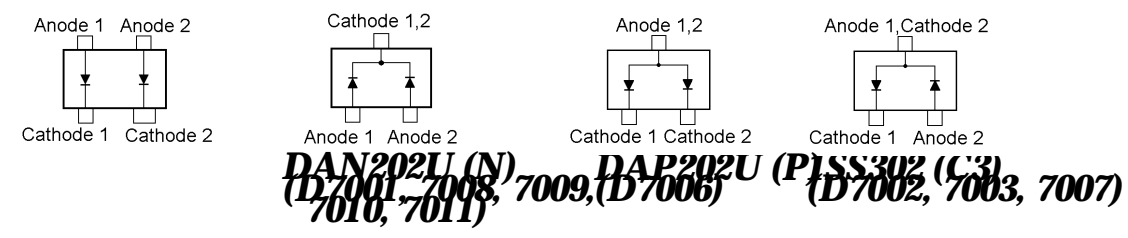

DAN202U (N) (D7001, 7008, 7009, D7006)
DAP202U (P1SS302) (C3) (D7002, 7003, 7007)
P1SS302 (C3) (D7002, 7003, 7007)

Parts List

REF.	DESCRIPTION	VALUE	V/W	TOL.	MFR'S DESIG	VXSTD P/N	VERS.	LOT.	SIDE	LAY ADR
*** CNTL-UNIT ***										
PCB with Components						CB0409003	USA			
PCB with Components						CB0409004	EXPORT			
Printed Circuit Board						FR001690D		1-		
Printed Circuit Board						FR001690E		4-		
BT7001	LITHIUM BATT.		3V		CR2025-TS1	Q9000446		1-	B	e2
C 7001	CHIP CAP.	10pF	50V	CH	GRM39CH100D50PT	K22174211		1	A	C2
C 7001	CHIP CAP.	100pF	50V	CH	GRM39CH101J50PT	K22174235		2-	A	C2
C 7002	CHIP CAP.	10pF	50V	CH	GRM39CH100D50PT	K22174211		1	A	D2
C 7002	CHIP CAP.	100pF	50V	CH	GRM39CH101J50PT	K22174235		2-	A	D2
C 7003	CHIP CAP.	10pF	50V	CH	GRM39CH100D50PT	K22174211		1	B	d2
C 7003	CHIP CAP.	100pF	50V	CH	GRM39CH101J50PT	K22174235		2-	B	d2
C 7004	CHIP CAP.	10pF	50V	CH	GRM39CH100D50PT	K22174211		1	A	C2
C 7004	CHIP CAP.	100pF	50V	CH	GRM39CH101J50PT	K22174235		2-	A	C2
C 7006	CHIP CAP.	0.01uF	25V	B	GRM39B103K25PT	K22144803		1-	A	A2
C 7007	CHIP CAP.	0.001uF	50V	B	GRM39B102K50PT	K22174821		1		
C 7008	CHIP CAP.	10pF	50V	CH	GRM39CH100D50PT	K22174211		1	B	g2
C 7008	CHIP CAP.	100pF	50V	CH	GRM39CH101J50PT	K22174235		2-	B	g2
C 7009	CHIP CAP.	10pF	50V	CH	GRM39CH100D50PT	K22174211		1	B	f1
C 7009	CHIP CAP.	100pF	50V	CH	GRM39CH101J50PT	K22174235		2-	B	f1
C 7010	CHIP CAP.	10pF	50V	CH	GRM39CH100D50PT	K22174211		1	A	C2
C 7010	CHIP CAP.	100pF	50V	CH	GRM39CH101J50PT	K22174235		2-	A	C2
C 7012	CHIP CAP.	10pF	50V	CH	GRM39CH100D50PT	K22174211		1	A	C2
C 7012	CHIP CAP.	0.001uF	50V	B	GRM39B102K50PT	K22174821		2-	A	C2
C 7013	CHIP CAP.	0.01uF	25V	B	GRM39B103K25PT	K22144803		1-	A	A2
C 7014	CHIP TA.CAP.	1uF	10V		TESVSP1A105M-8R	K78100032		1-	A	A2
C 7015	CHIP CAP.	27pF	50V	CH	GRM39CH270J50PT	K22174221		1	A	E2
C 7015	CHIP CAP.	5pF	50V	CH	GRM39CH050C50PT	K22174206		2-	A	E2
C 7016	CHIP CAP.	33pF	50V	CH	GRM39CH330J50PT	K22174223		1-	B	f2
C 7017	CHIP CAP.	27pF	50V	CH	GRM39CH270J50PT	K22174221		1	A	E2
C 7017	CHIP CAP.	5pF	50V	CH	GRM39CH050C50PT	K22174206		2-	A	E2
C 7017	CHIP CAP.	2pF	50V	CK	GRM39CK020C50PT	K22174203		6-	A	E2
C 7018	CHIP CAP.	33pF	50V	CH	GRM39CH330J50PT	K22174223		1-	B	f2
C 7019	CHIP CAP.	0.001uF	50V	B	GRM39B102K50PT	K22174821		1-	A	A2
C 7020	CHIP CAP.	0.001uF	50V	B	GRM39B102K50PT	K22174821		1-	A	A2
C 7021	CHIP CAP.	0.01uF	25V	B	GRM39B103K25PT	K22144803		1-	A	B1
C 7022	CHIP TA.CAP.	10uF	16V		TEMSVB21C106M-8R	K78120025		1-	A	B1
C 7023	CHIP TA.CAP.	10uF	10V		TEMSVA1A106M-8R	K78100028		1-	A	F1
C 7024	CHIP CAP.	0.033uF	16V	R	GRM39R333K16PT	K22124801		1-	A	G1
C 7025	CHIP TA.CAP.	10uF	10V		TEMSVA1A106M-8R	K78100028		1-	B	a1
C 7026	CHIP CAP.	0.01uF	25V	B	GRM39B103K25PT	K22144803		1-	A	F1
C 7027	CHIP CAP.	0.01uF	25V	B	GRM39B103K25PT	K22144803		1-	A	F1
C 7028	CHIP TA.CAP.	1uF	10V		TESVSP1A105M-8R	K78100032		1-	A	F1
C 7029	CHIP CAP.	0.1uF	16V	B	GRM39B104K16PT	K22124805		1-	A	F1
C 7030	CHIP CAP.	0.01uF	25V	B	GRM39B103K25PT	K22144803		1-	A	B1
C 7031	CHIP TA.CAP.	1uF	10V		TESVSP1A105M-8R	K78100032		1	B	f1
C 7031	CHIP TA.CAP.	0.33uF	16V		TESVSP1C334M-8R	K78120029		2-	B	f1
C 7032	CHIP CAP.	0.01uF	25V	B	GRM39B103K25PT	K22144803		1-	A	E1
C 7033	CHIP CAP.	220pF	50V	CH	GRM39CH221J50PT	K22174243		1-	A	G1
C 7034	CHIP TA.CAP.	10uF	16V		TEMSVB21C106M-8R	K78120025		1	A	B1
C 7034	CHIP TA.CAP.	22uF	16V		TEMSVB21C226M-8R	K78120028		2-	A	B1
C 7035	CHIP TA.CAP.	10uF	16V		TEMSVB21C106M-8R	K78120025		1-	A	E1
C 7036	CHIP CAP.	0.033uF	16V	R	GRM39R333K16PT	K22124801		1-	A	F1
C 7037	CHIP TA.CAP.	4.7uF	10V		TEMSVA1A475M-8R	K78100022		1	A	F1
C 7037	CHIP TA.CAP.	1uF	16V		TESVA1C105M1-8R	K78120009		2-	A	F1
C 7038	CHIP CAP.	0.033uF	16V	R	GRM39R333K16PT	K22124801		1-	A	F1
C 7039	CHIP TA.CAP.	10uF	16V		TEMSVB21C106M-8R	K78120025		1-	B	e1
C 7040	CHIP CAP.	0.01uF	25V	B	GRM39B103K25PT	K22144803		1-	B	e1
C 7041	CHIP CAP.	10pF	50V	CH	GRM39CH100D50PT	K22174211		1	A	E1
C 7041	CHIP CAP.	0.001uF	50V	B	GRM39B102K50PT	K22174821		2-	A	E1
C 7042	CHIP CAP.	10pF	50V	CH	GRM39CH100D50PT	K22174211		1	A	D1
C 7042	CHIP CAP.	100pF	50V	CH	GRM39CH101J50PT	K22174235		2-	A	D1
C 7043	CHIP TA.CAP.	10uF	10V		TEMSVA1A106M-8R	K78100028		1-	A	A2
C 7044	CHIP CAP.	10pF	50V	CH	GRM39CH100D50PT	K22174211		1	A	D1
C 7044	CHIP CAP.	100pF	50V	CH	GRM39CH101J50PT	K22174235		2-	A	D1
C 7045	CHIP CAP.	10pF	50V	CH	GRM39CH100D50PT	K22174211		1	A	F1
C 7045	CHIP CAP.	0.001uF	50V	B	GRM39B102K50PT	K22174821		2-	A	F1
C 7046	CHIP CAP.	10pF	50V	CH	GRM39CH100D50PT	K22174211		1	A	D1

CNTL Unit

REF.	DESCRIPTION	VALUE	V/W	TOL.	MFR'S DESIG	VXSTD P/N	VERS.	LOT.	SIDE	LAY ADR
C 7046	CHIP CAP.	100pF	50V	CH	GRM39CH101J50PT	K22174235		2-	A	D1
C 7047	CHIP CAP.	10pF	50V	CH	GRM39CH100D50PT	K22174211		1	A	F1
C 7047	CHIP CAP.	0.001uF	50V	B	GRM39B102K50PT	K22174821		2-	A	F1
C 7048	CHIP CAP.	0.01uF	25V	B	GRM39B103K25PT	K22144803		1-	A	A2
C 7049	CHIP CAP.	10pF	50V	CH	GRM39CH100D50PT	K22174211		1	A	D1
C 7049	CHIP CAP.	100pF	50V	CH	GRM39CH101J50PT	K22174235		2-	A	D1
C 7050	CHIP CAP.	10pF	50V	CH	GRM39CH100D50PT	K22174211		1	A	F1
C 7050	CHIP CAP.	0.001uF	50V	B	GRM39B102K50PT	K22174821		2-	A	F1
C 7051	CHIP CAP.	10pF	50V	CH	GRM39CH100D50PT	K22174211		1	A	F1
C 7051	CHIP CAP.	0.001uF	50V	B	GRM39B102K50PT	K22174821		2-	A	F1
C 7052	CHIP CAP.	10pF	50V	CH	GRM39CH100D50PT	K22174211		1	A	F1
C 7052	CHIP CAP.	0.001uF	50V	B	GRM39B102K50PT	K22174821		2-	A	F1
C 7053	CHIP CAP.	10pF	50V	CH	GRM39CH100D50PT	K22174211		1	A	D1
C 7053	CHIP CAP.	100pF	50V	CH	GRM39CH101J50PT	K22174235		2-	A	D1
C 7054	CHIP CAP.	10pF	50V	CH	GRM39CH100D50PT	K22174211		1	A	B1
C 7054	CHIP CAP.	0.001uF	50V	B	GRM39B102K50PT	K22174821		2-	A	B1
C 7055	CHIP CAP.	10pF	50V	CH	GRM39CH100D50PT	K22174211		1	A	F1
C 7055	CHIP CAP.	0.001uF	50V	B	GRM39B102K50PT	K22174821		2-	A	F1
C 7056	CHIP CAP.	10pF	50V	CH	GRM39CH100D50PT	K22174211		1	A	D1
C 7056	CHIP CAP.	100pF	50V	CH	GRM39CH101J50PT	K22174235		2-	A	D1
C 7057	CHIP CAP.	10pF	50V	CH	GRM39CH100D50PT	K22174211		1	A	B1
C 7057	CHIP CAP.	0.001uF	50V	B	GRM39B102K50PT	K22174821		2-	A	B1
C 7058	CHIP CAP.	10pF	50V	CH	GRM39CH100D50PT	K22174211		1	A	F1
C 7058	CHIP CAP.	0.001uF	50V	B	GRM39B102K50PT	K22174821		2-	A	F1
C 7059	CHIP CAP.	0.01uF	25V	B	GRM39B103K25PT	K22144803		1-	A	A2
C 7060	CHIP CAP.	10pF	50V	CH	GRM39CH100D50PT	K22174211		1	A	B1
C 7060	CHIP CAP.	0.001uF	50V	B	GRM39B102K50PT	K22174821		2-	A	B1
C 7061	CHIP CAP.	10pF	50V	CH	GRM39CH100D50PT	K22174211		1	A	F1
C 7061	CHIP CAP.	0.001uF	50V	B	GRM39B102K50PT	K22174821		2-	A	F1
C 7062	CHIP TA.CAP.	10uF	16V		TEMSVB21C106M-8R	K78120025		1-	B	f2
C 7063	CHIP CAP.	10pF	50V	CH	GRM39CH100D50PT	K22174211		1	A	B1
C 7063	CHIP CAP.	0.001uF	50V	B	GRM39B102K50PT	K22174821		2-	A	B1
C 7064	CHIP CAP.	10pF	50V	CH	GRM39CH100D50PT	K22174211		1	A	F2
C 7064	CHIP CAP.	100pF	50V	CH	GRM39CH101J50PT	K22174235		2-	A	F2
C 7065	CHIP CAP.	10pF	50V	CH	GRM39CH100D50PT	K22174211		1	A	F2
C 7065	CHIP CAP.	100pF	50V	CH	GRM39CH101J50PT	K22174235		2-	A	F2
C 7066	CHIP TA.CAP.	1uF	10V		TESVSP1A105M-8R	K78100032		1		
C 7067	CHIP TA.CAP.	1uF	10V		TESVSP1A105M-8R	K78100032		1		
C 7068	CHIP TA.CAP.	1uF	10V		TESVSP1A105M-8R	K78100032		1		
C 7069	CHIP TA.CAP.	1uF	10V		TESVSP1A105M-8R	K78100032		1		
C 7070	CHIP TA.CAP.	1uF	10V		TESVSP1A105M-8R	K78100032		1		
C 7071	CHIP CAP.	0.01uF	25V	B	GRM39B103K25PT	K22144803		1		
C 7072	CHIP CAP.	0.01uF	25V	B	GRM39B103K25PT	K22144803		1-	A	E2
C 7073	CHIP CAP.	0.01uF	25V	B	GRM39B103K25PT	K22144803		1-	B	a2
C 7074	CHIP CAP.	0.01uF	25V	B	GRM39B103K25PT	K22144803		1-	A	C1
C 7075	CHIP CAP.	0.01uF	25V	B	GRM39B103K25PT	K22144803		1-	A	G1
C 7076	CHIP CAP.	0.01uF	25V	B	GRM39B103K25PT	K22144803		1-	B	a1
C 7077	CHIP CAP.	0.01uF	25V	B	GRM39B103K25PT	K22144803		1-	A	E1
C 7078	CHIP CAP.	0.047uF	16V	B	GRM39B473K16PT	K22124804		1-	A	B1
C 7079	CHIP TA.CAP.	1uF	16V		TESVA1C105M1-8R	K78120009		2-	B	d1
C 7080	CHIP TA.CAP.	1uF	25V		TEMSVA1E105M-8R	K78140013		2-	B	f1
C 7081	CHIP TA.CAP.	10uF	10V		TEMSVA1A106M-8R	K78100028		2-	A	B2
C 7082	CHIP CAP.	0.001uF	50V	B	GRM39B102K50PT	K22174821		2-	A	F2
C 7083	CHIP CAP.	0.001uF	50V	B	GRM39B102K50PT	K22174821		2-	A	E2
C 7084	CHIP CAP.	0.001uF	50V	B	GRM39B102K50PT	K22174821		2-	A	E2
C 7086	CHIP CAP.	0.047uF	16V	B	GRM39B473K16PT	K22124804		2-	B	f2
C 7087	CHIP CAP.	0.001uF	50V	B	GRM39B102K50PT	K22174821		2-	B	f1
C 7090	CHIP CAP.	0.001uF	50V	B	GRM39B102K50PT	K22174821		5-	B	c2
C 7091	CHIP CAP.	33pF	50V	CH	GRM39CH330J50PT	K22174223		5	B	c2
C 7091	CHIP CAP.	47pF	50V	CH	GRM39CH470J50PT	K22174227		6-	B	c2
C 7093	CHIP TA.CAP.	10uF	6.3V		TESVSP0J106M-8R	K78080055		3-	A	E2
C 7094	TANTALUM CAP.	0.22uF	35V		TPDN1VR22M8S(MX0)	K76160017		2-		
C 7095	CHIP CAP.	100pF	50V	CH	GRM39CH101J50PT	K22174235		3-		
CO7001	CERAMIC OSC	32MHz			CSACV32.00MX040-TC20	H7901310		1-2	B	c2
CO7002	CERAMIC OSC	8MHz			CSACS8.00MT-TC	H7901280		1-	B	f2
D 7001	DIODE				DAN202U T106	G2070162		1-	A	C1
D 7002	DIODE				1SS302 TE85R	G2070088		1-	B	f2
D 7003	DIODE				1SS302 TE85R	G2070088		1-	B	f1

REF.	DESCRIPTION	VALUE	V/W	TOL.	MFR'S DESIG	VXSTD P/N	VERS.	LOT.	SIDE	LAY ADR
D 7004	DIODE				DA227-TR	G2070292		1-	B	f2
D 7005	DIODE				1SS319 TE85R	G2070080		1-	A	F2
D 7006	DIODE				DAP202U T106	G2070160		1-	B	a1
D 7007	DIODE				1SS302 TE85R	G2070088		1-	A	G1
D 7008	DIODE				DAN202U T106	G2070162		1-	A	F1
D 7009	DIODE				DAN202U T106	G2070162		2-	A	B2
D 7010	DIODE				DAN202U T106	G2070162		2-	A	B2
D 7011	DIODE				DAN202U T106	G2070162		2-	B	f2
D 7012	DIODE				1SS270TJ	G2060004		4		
J 7001	CONNECTOR				12FMZ-BT	P1090901		1-	B	d2
J 7002	CONNECTOR				B4B-PH-K-S	P0090398		1-	B	c2
J 7003	CONNECTOR				S6B-ZR	P0090926		1-	B	g1
J 7004	CONNECTOR				00 6200 516 230 000	P1090940		1-	B	c1
J 7005	CONNECTOR				00 6200 520 330 000	P1090930		1-	B	b1
J 7006	CONNECTOR				00 6200 520 330 000	P1090930		1-	B	e1
J 7007	CONNECTOR				B4B-PH-K-S	P0090398		1-	B	b2
J 7008	CONNECTOR				B4B-PH-K-S	P0090398		1-	B	b2
L 7002	M.RFC	22uH			LK2125 220M-T	L1690335		1-	A	A1
L 7003	M.RFC	22uH			LK2125 220M-T	L1690335		1-	B	g1
L 7004	M.RFC	22uH			LK2125 220M-T	L1690335		1-	B	g1
Q 7001	TRANSISTOR				2SC4047-TA	G3340477		1-	B	b2
Q 7002	TRANSISTOR				2SC4047-TA	G3340477		1-	A	F2
Q 7003	IC				TC7W08FU TE12L	G1092264		1-	A	D2
Q 7004	IC				AK93C85AM E-1	G1092706		1-	B	b2
Q 7005	IC				24LC02BTI/SN(TAPING)	G1092237		1-	B	f2
Q 7006	IC				TC7W08FU TE12L	G1092264		1-	A	E1
Q 7007	IC				AK93C85AM E-1	G1092706		1-	B	b2
Q 7008	IC				MB89133APFM-G-258-BND	G1092046		1-	A	B2
Q 7009	IC				TC7W08FU TE12L	G1092264		1		
Q 7010	IC				UPD78P4038GC-8BT	*		1	A	D2
Q 7010	IC				UPD78P4038GC-8BT	*	EXPORT	2-	A	D2
Q 7010	IC				UPD784036GC-841-8BT	*	EXPORT	9-	A	D2
Q 7010	IC				UPD78P4038GC-8BT	*	USA	2-	A	D2
Q 7010	IC				UPD78P4038GC-8BT	*	USA	5-	A	D2
Q 7010	IC				UPD784036GC-842-8BT	*	USA	9-	A	D2
Q 7010	IC				UPD784036GC-854-8BT	*	USA	22-	A	D2
Q 7011	IC				MC14028BFL	G1090998		1-	A	D1
Q 7012	TRANSISTOR				2SC4047-TA	G3340477		1-	B	f2
Q 7013	IC				TD62783AFN(EL)	G1092700		1-	A	C1
Q 7014	TRANSISTOR				2SC4047-TA	G3340477		1-	A	B1
Q 7015	TRANSISTOR				2SC4047-TA	G3340477		1-	A	B1
Q 7016	TRANSISTOR				2SC4047-TA	G3340477		1-	A	C1
Q 7017	TRANSISTOR				2SC4047-TA	G3340477		1-	A	C1
Q 7018	IC				NJM2904V-TE1	G1091677		1-	B	a1
Q 7019	IC				PQ20VZ1U	G1092705		1-	A	A1
Q 7020	TRANSISTOR				2SC4047-TA	G3340477		1-	A	F2
Q 7021	IC				NJM2904V-TE1	G1091677		1-	B	a1
Q 7022	IC				TC4W53FU TE12L	G1091675		1-	A	E1
Q 7023	TRANSISTOR				2SB624-T2B BV4	G3206247D		1-	A	F2
Q 7024	IC				NJM78L05UA TE1	G1091325		1-	A	F1
Q 7025	IC				M51951AML-600C	G1091131		1-	A	F1
Q 7026	IC				NJM2904V-TE1	G1091677		1-	B	f1
Q 7027	IC				L78M05T-TL	G1091731		1-	B	g2
Q 7029	TRANSISTOR				FMC5A T148	G3070185		1-	B	b1
Q 7030	TRANSISTOR				FMC5A T148	G3070185		1-	B	b1
Q 7031	IC				TC7S04FU TE85R	G1091530		2-	A	D1
Q 7032	IC				TC7S32FU TE85R	G1091529		2-	A	B2
Q 7034	IC				TC7S04FU TE85R	G1091530		2-	A	D1
Q 7035	TRANSISTOR				2SA1563-TB	G3115638		2-	B	c1
Q 7036	TRANSISTOR				2SC4047-TA	G3340477		2-	A	B2
Q 7037	IC				NJM78L05UA TE1	G1091325		2-	B	f1
Q 7038	IC				M51951AML-600C	G1091131		2-	A	B2
Q 7039	TRANSISTOR				2SC4047-TA	G3340477		2-	A	C2
Q 7040	TRANSISTOR				DTC114EU T106	G3070084		5	B	b2
Q 7040	TRANSISTOR				2SC5006-T1	G3350068		6-	B	b2
Q 7042	TRANSISTOR				BA1A4P-T	G3050003		4		
R 7001	CHIP RES.	1k	1/16W	5%	RMC1/16 102JATP	J24185102		1-	B	c1
R 7003	CHIP RES.	1k	1/16W	5%	RMC1/16 102JATP	J24185102		1-	B	f2

* Please contact VERTEX STANDARD.

CNTL Unit

REF.	DESCRIPTION	VALUE	V/W	TOL.	MFR'S DESIG	VXSTD P/N	VERS.	LOT.	SIDE	LAY ADR
R 7004	CHIP RES.	1k	1/16W	5%	RMC1/16 102JATP	J24185102		1-	B	f1
R 7005	CHIP RES.	100	1/16W	5%	RMC1/16 101JATP	J24185101		1	A	C2
R 7005	CHIP RES.	5.6k	1/16W	5%	RMC1/16 562JATP	J24185562		2-	A	C2
R 7006	CHIP RES.	100	1/16W	5%	RMC1/16 101JATP	J24185101		1-	B	d2
R 7007	CHIP RES.	100	1/16W	5%	RMC1/16 101JATP	J24185101		1-	B	d2
R 7008	CHIP RES.	100	1/16W	5%	RMC1/16 101JATP	J24185101		1-	B	d2
R 7009	CHIP RES.	100	1/16W	5%	RMC1/16 101JATP	J24185101		1-	B	d2
R 7010	CHIP RES.	100	1/16W	5%	RMC1/16 101JATP	J24185101		1-	B	d2
R 7011	CHIP RES.	100	1/16W	5%	RMC1/16 101JATP	J24185101		1		
R 7012	CHIP RES.	47k	1/16W	5%	RMC1/16 473JATP	J24185473		1-	B	f2
R 7013	CHIP RES.	47k	1/16W	5%	RMC1/16 473JATP	J24185473		1-	B	f2
R 7014	CHIP RES.	47k	1/16W	5%	RMC1/16 473JATP	J24185473		1		
R 7015	CHIP RES.	47k	1/16W	5%	RMC1/16 473JATP	J24185473		1-	B	c2
R 7016	CHIP RES.	47k	1/16W	5%	RMC1/16 473JATP	J24185473		1-	B	f2
R 7017	CHIP RES.	47k	1/16W	5%	RMC1/16 473JATP	J24185473		1-	B	f2
R 7018	CHIP RES.	1k	1/16W	5%	RMC1/16 102JATP	J24185102		1-	B	f2
R 7019	CHIP RES.	1k	1/16W	5%	RMC1/16 102JATP	J24185102		1-	B	f2
R 7020	CHIP RES.	2.2k	1/16W	5%	RMC1/16 222JATP	J24185222		1-	B	b2
R 7021	CHIP RES.	47k	1/16W	5%	RMC1/16 473JATP	J24185473		1-	B	a2
R 7022	CHIP RES.	1k	1/16W	5%	RMC1/16 102JATP	J24185102		1		
R 7023	CHIP RES.	47k	1/16W	5%	RMC1/16 473JATP	J24185473		1-	A	G1
R 7024	CHIP RES.	10k	1/16W	5%	RMC1/16 103JATP	J24185103		1		
R 7025	CHIP RES.	47k	1/16W	5%	RMC1/16 473JATP	J24185473		1-	A	G1
R 7026	CHIP RES.	10k	1/16W	5%	RMC1/16 103JATP	J24185103		1	A	F1
R 7026	CHIP RES.	47k	1/16W	5%	RMC1/16 473JATP	J24185473		2-	A	F1
R 7027	CHIP RES.	4.7k	1/16W	5%	RMC1/16 472JATP	J24185472		1-	B	f1
R 7028	CHIP RES.	560	1/16W	5%	RMC1/16 561JATP	J24185561		1-	A	F1
R 7029	CHIP RES.	33k	1/16W	5%	RMC1/16 333JATP	J24185333		1-	A	F1
R 7030	CHIP RES.	10k	1/16W	5%	RMC1/16 103JATP	J24185103		1-	A	F1
R 7031	CHIP RES.	33k	1/16W	5%	RMC1/16 333JATP	J24185333		1-	A	G1
R 7032	CHIP RES.	4.7k	1/16W	5%	RMC1/16 472JATP	J24185472		1-	A	F1
R 7033	CHIP RES.	10k	1/16W	5%	RMC1/16 103JATP	J24185103		1	B	f1
R 7033	CHIP RES.	100k	1/16W	1%	RMC1/16 104FTP	J24183104		2-	B	f1
R 7034	CHIP RES.	10k	1/16W	5%	RMC1/16 103JATP	J24185103		1	B	f1
R 7034	CHIP RES.	180k	1/16W	1%	RMC1/16 184FTP	J24183184		2-	B	f1
R 7035	CHIP RES.	10k	1/16W	1%	RMC1/16 103FTP	J24183103		1-	B	f1
R 7036	CHIP RES.	4.7k	1/16W	5%	RMC1/16 472JATP	J24185472		1	A	F1
R 7036	CHIP RES.	2.2k	1/16W	5%	RMC1/16 222JATP	J24185222		2-	A	F1
R 7037	CHIP RES.	1.5k	1/16W	5%	RMC1/16 152JATP	J24185152		1	A	F1
R 7037	CHIP RES.	1k	1/16W	5%	RMC1/16 102JATP	J24185102		2-	A	F1
R 7038	CHIP RES.	4.7k	1/16W	5%	RMC1/16 472JATP	J24185472		1	A	F1
R 7038	CHIP RES.	2.2k	1/16W	5%	RMC1/16 222JATP	J24185222		2-	A	F1
R 7039	CHIP RES.	1k	1/16W	5%	RMC1/16 102JATP	J24185102		1-	B	f1
R 7040	CHIP RES.	2.7k	1/16W	1%	RMC1/16 272FTP	J24183272		1-	B	f1
R 7041	CHIP RES.	4.7k	1/16W	5%	RMC1/16 472JATP	J24185472		1-	A	F1
R 7042	CHIP RES.	100k	1/16W	5%	RMC1/16 104JATP	J24185104		1-	A	F1
R 7043	CHIP RES.	180k	1/16W	5%	RMC1/16 184JATP	J24185184		1-	A	F1
R 7044	CHIP RES.	2.2M	1/16W	5%	RMC1/16 225JATP	J24185225		1	A	F1
R 7044	CHIP RES.	1.5M	1/16W	5%	RMC1/16 155JATP	J24185155		2-	A	F1
R 7045	CHIP RES.	47k	1/16W	5%	RMC1/16 473JATP	J24185473		1-	A	F1
R 7046	CHIP RES.	4.7k	1/16W	5%	RMC1/16 472JATP	J24185472		1-	A	F1
R 7047	CHIP RES.	47k	1/16W	5%	RMC1/16 473JATP	J24185473		1-	A	F1
R 7048	CHIP RES.	47k	1/16W	5%	RMC1/16 473JATP	J24185473		1	A	F1
R 7048	CHIP RES.	10k	1/16W	5%	RMC1/16 103JATP	J24185103		2-	A	F1
R 7049	CHIP RES.	100	1/16W	5%	RMC1/16 101JATP	J24185101		1-	A	B1
R 7050	CHIP RES.	100	1/16W	5%	RMC1/16 101JATP	J24185101		1-	A	B1
R 7051	CHIP RES.	100	1/16W	5%	RMC1/16 101JATP	J24185101		1-	A	B1
R 7052	CHIP RES.	100	1/16W	5%	RMC1/16 101JATP	J24185101		1-	A	B1
R 7053	CHIP RES.	100	1/16W	5%	RMC1/16 101JATP	J24185101		1-	A	D1
R 7054	CHIP RES.	100	1/16W	5%	RMC1/16 101JATP	J24185101		1-	A	D1
R 7055	CHIP RES.	100	1/16W	5%	RMC1/16 101JATP	J24185101		1-	A	D1
R 7056	CHIP RES.	100	1/16W	5%	RMC1/16 101JATP	J24185101		1-	A	D1
R 7057	CHIP RES.	100	1/16W	5%	RMC1/16 101JATP	J24185101		1-	A	D1
R 7058	CHIP RES.	100	1/16W	5%	RMC1/16 101JATP	J24185101		1-	A	D1
R 7059	CHIP RES.	100	1/16W	5%	RMC1/16 101JATP	J24185101		1-	A	F1
R 7060	CHIP RES.	100	1/16W	5%	RMC1/16 101JATP	J24185101		1-	A	F1
R 7061	CHIP RES.	100	1/16W	5%	RMC1/16 101JATP	J24185101		1-	A	F1
R 7062	CHIP RES.	100	1/16W	5%	RMC1/16 101JATP	J24185101		1-	A	F1

REF.	DESCRIPTION	VALUE	V/W	TOL.	MFR'S DESIG	VXSTD P/N	VERS.	LOT.	SIDE	LAY ADR
R 7063	CHIP RES.	100	1/16W	5%	RMC1/16 101JATP	J24185101		1-	A	F1
R 7064	CHIP RES.	100	1/16W	5%	RMC1/16 101JATP	J24185101		1-	A	F1
R 7065	CHIP RES.	100	1/16W	5%	RMC1/16 101JATP	J24185101		1-	A	F1
R 7066	CHIP RES.	100	1/16W	5%	RMC1/16 101JATP	J24185101		1-	A	F1
R 7067	CHIP RES.	100	1/16W	5%	RMC1/16 101JATP	J24185101		1-	A	E1
R 7068	CHIP RES.	3.3	1W	5%	RMC1 3R3JTE	J24305339		1-	A	A1
R 7069	CHIP RES.	100	1/16W	5%	RMC1/16 101JATP	J24185101		1-	A	F2
R 7070	CHIP RES.	100	1/16W	5%	RMC1/16 101JATP	J24185101		1-	A	F2
R 7071	CHIP RES.	100	1/16W	5%	RMC1/16 101JATP	J24185101		1		
R 7072	CHIP RES.	1k	1/16W	5%	RMC1/16 102JATP	J24185102		1-	A	E1
R 7073	CHIP RES.	10k	1/16W	5%	RMC1/16 103JATP	J24185103		1-	A	E1
R 7074	CHIP RES.	10k	1/16W	5%	RMC1/16 103JATP	J24185103		1	A	E1
R 7074	CHIP RES.	2.2k	1/16W	5%	RMC1/16 222JATP	J24185222		2	A	E1
R 7074	CHIP RES.	0	1/16W	5%	RMC1/16 000JATP	J24185000		3-	A	E1
R 7075	CHIP RES.	1k	1/16W	5%	RMC1/16 102JATP	J24185102		1	B	b1
R 7075	CHIP RES.	18k	1/16W	5%	RMC1/16 183JATP	J24185183		2	B	b1
R 7075	CHIP RES.	10k	1/16W	5%	RMC1/16 103JATP	J24185103		3-	B	b1
R 7076	CHIP RES.	10k	1/16W	5%	RMC1/16 103JATP	J24185103		1-	A	B1
R 7078	CHIP RES.	100	1/16W	5%	RMC1/16 101JATP	J24185101		1	B	b2
R 7078	CHIP RES.	100	1/16W	5%	RMC1/16 101JATP	J24185101		2-	B	b2
R 7079	CHIP RES.	100	1/16W	5%	RMC1/16 101JATP	J24185101		1	B	b2
R 7079	CHIP RES.	100	1/16W	5%	RMC1/16 101JATP	J24185101		2-	B	b2
R 7080	CHIP RES.	100	1/16W	5%	RMC1/16 101JATP	J24185101		1-	B	b2
R 7081	CHIP RES.	100	1/16W	5%	RMC1/16 101JATP	J24185101		1-	B	b2
R 7082	CHIP RES.	47k	1/16W	5%	RMC1/16 473JATP	J24185473		2-	B	b2
R 7083	CHIP RES.	100k	1/16W	5%	RMC1/16 104JATP	J24185104		2-	B	a1
R 7084	CHIP RES.	100k	1/16W	5%	RMC1/16 104JATP	J24185104		2-	A	D2
R 7086	CHIP RES.	4.7k	1/16W	5%	RMC1/16 472JATP	J24185472		2-	B	d1
R 7087	CHIP RES.	4.7k	1/16W	5%	RMC1/16 472JATP	J24185472		2-	A	B2
R 7088	CHIP RES.	47k	1/16W	5%	RMC1/16 473JATP	J24185473		2-	A	B2
R 7089	CHIP RES.	10k	1/16W	5%	RMC1/16 103JATP	J24185103		2-	A	B2
R 7090	CHIP RES.	1.8k	1/16W	5%	RMC1/16 182JATP	J24185182		2-	B	f1
R 7091	CHIP RES.	270	1/16W	5%	RMC1/16 271JATP	J24185271		2-	B	f2
R 7092	CHIP RES.	3.9k	1/16W	5%	RMC1/16 392JATP	J24185392		2-	B	f2
R 7094	CHIP RES.	3.3k	1/10W	5%	RMC1/10T 332J	J24205332		2-	A	F1
R 7094	CHIP RES.	3.3k	1/16W	5%	RMC1/16 332JATP	J24185332		4-	A	F1
R 7095	CARBON FILM RES.	10k	1/6W	5%	RD16TPJ103 10K	J07225103		2-	B	f2
R 7095	CHIP RES.	10k	1/16W	5%	RMC1/16 103JATP	J24185103		4-	B	f2
R 7096	CHIP RES.	0	1/16W	5%	RMC1/16 000JATP	J24185000		4-	B	c2
R 7097	CHIP RES.	0	1/16W	5%	RMC1/16 000JATP	J24185000		5-	B	c1
R 7100	CHIP RES.	0	1/16W	5%	RMC1/16 000JATP	J24185000		5	B	b2
R 7100	CHIP RES.	10k	1/16W	5%	RMC1/16 103JATP	J24185103		6-	B	b2
R 7101	CARBON FILM RES.	4.7k	1/6W	5%	RD16TPJ472 4.7K	J07225472		4		
S 7001	SLIDE SWITCH				SSSS8-12B-12	N6090093		2-	B	f1
X 7001	XTAL MA-306	32MHz			32.0MHZ	H0103215		3-	B	c2
	MYLAR SHEET					R7130220		1-		
	PAD					RA0115600		2-		
	PAD					RA0149100		2-		

CNTL Unit

Note:

Connect-1 Unit

Parts Layout

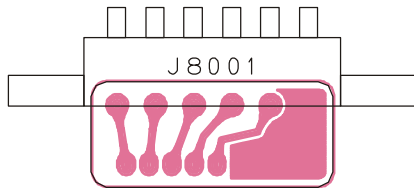

Side A

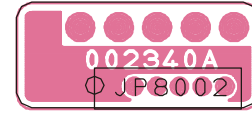

Side B

Parts List

REF.	DESCRIPTION	VALUE	V/W	TOL.	MFR'S DESIG	VXSTD P/N	VERS.	LOT.	SIDE	LAY ADR
*** CONNECT-1 UNIT ***										
	PCB with Components					CB0558001				
	Printed Circuit Board					FR002560A		1-		
J 8001	CONNECTOR				CLE9006-0101R	P1090681		1-	A	
JP8002	WIRE ASSY				A0898	T9206742		1-	B	

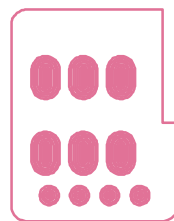

Connect-2 Unit

Parts Layout

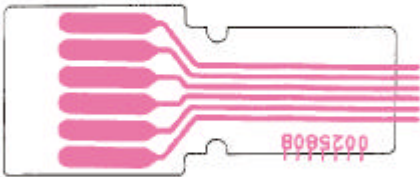

Side A

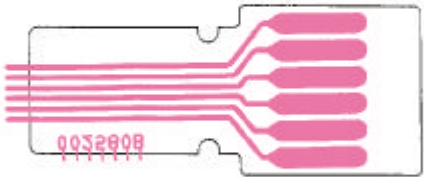

Side B

Parts List

REF.	DESCRIPTION	VALUE	V/W	TOL.	MFR'S DESIG	VXSTD P/N	VERS.	LOT.	SIDE	LAY ADR
*** CONNECT-2 UNIT ***										
	PCB with Components					CB0561001			1-	
	Printed Circuit Board					FR002580B				
JP8201	WIRE ASSY					T9206739			1-	

TCXO-8 High-Stability Reference Oscillator (option)

o

FTS-27 CTCSS Tone Squelch Unit (option)

Circuit Diagram

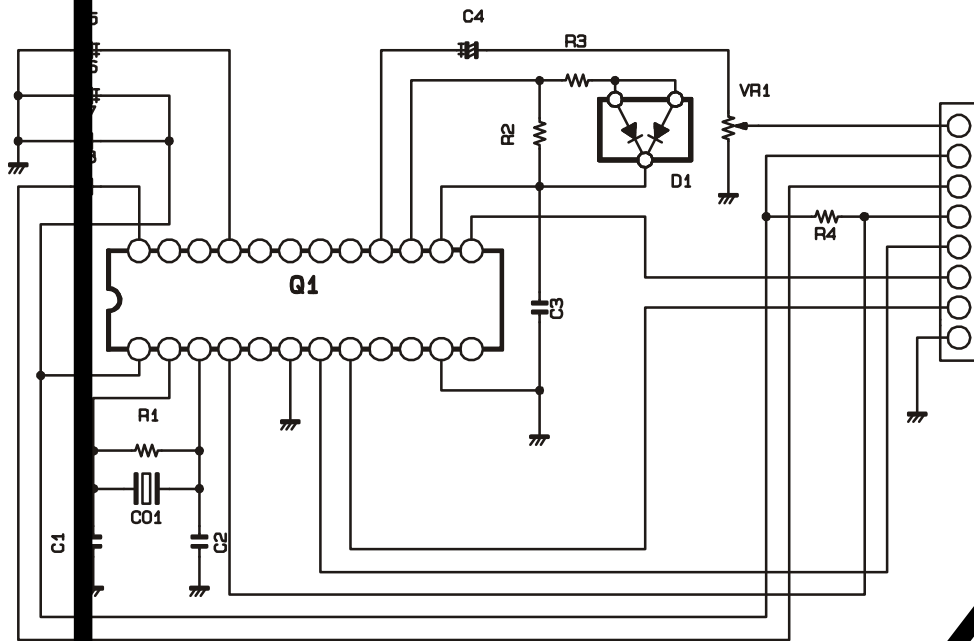

Parts Layout

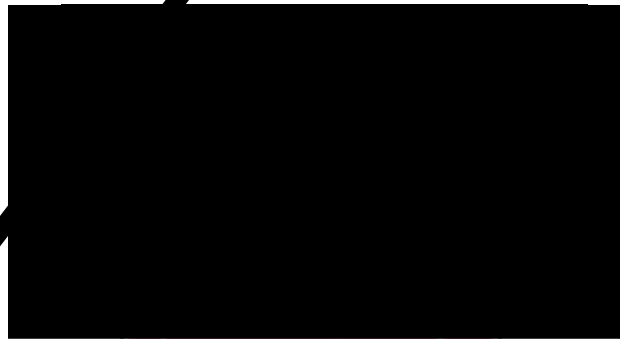

Side B

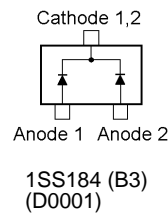
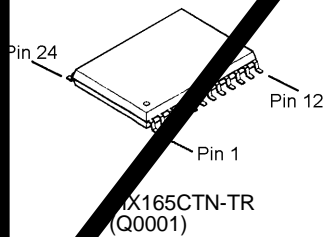

FTS-27 CTCSS Tone Squelch Unit (option)

Parts List

REF.	DESCRIPTION	VALUE	V/W	TOL.	MFR'S DESIG	VXSTD P/N	VERS.	LOT.	SIDE	LAY ADR
*** FTS-27 ***										
	Printed Circuit Board					F3351101			1-	
	Printed Circuit Board					F3351101A			15-	
C 0001	CHIP CAP.	68pF	50V	CH	GRM40CH680J50PT	K22170231			1-	A
C 0002	CHIP CAP.	68pF	50V	CH	GRM40CH680J50PT	K22170231			1-	A
C 0003	CHIP CAP.	0.1uF	25V	B	GRM40B104M25PT	K22140811			1-	A
C 0004	TANTALUM CHIP CAP.	1uF	16V		TESVA1C105MI-8R	K78120009			1-	A
C 0005	TANTALUM CHIP CAP.	0.47uF	25V		TESVA1E474M1-8R	K78140009			1-	A
C 0006	TANTALUM CHIP CAP.	6.8uF	6.3V		TESVB20J685M8R	K78080010			1-	A
C 0007	CHIP CAP.	0.001uF	50V	B	GRM40B102M50PT	K22170805			1-	A
C 0008	CHIP CAP.	0.1uF	25V	B	GRM40B104M25PT	K22140811			1-	A
CO0001	CERAMIC OSC				KBR-1000YTR17	H7900840			1-	A
D 0001	DIODE				1SS184 TE85R	G2070009			1-	A
P 0001	WIRE-ASSY					T9206255			1-	A
Q 0001	IC				MX265DW-TR	G1091670			1-	A
Q 0001	IC				MX165CTN-TR	G1092117			15-	A
R 0001	CHIP RES.	1M	1/10W	5%	RMC1/10T 105J	J24205105			1-	A
R 0002	CHIP RES.	2.2M	1/10W	5%	RMC1/10T 225J	J24205225			1-	A
R 0003	CHIP RES.	330K	1/10W	5%	RMC1/10T 334J	J24205334			1-	A
R 0004	CHIP RES.	8.2K	1/10W	5%	RMC1/10T 822J	J24205822			1-	A
VR0001	POT.	47K			EVM-7JS-X30-BQ4	J51788473			1-	A
	RUBBER SPONGE					R7146670			1-	



Copyright © 2003
VERTEX STANDARD CO., LTD.
All rights reserved

No portion of this manual may be reproduced without the permission of VERTEX STANDARD CO., LTD.

