

INSTRUCTION MANUAL FL-7000

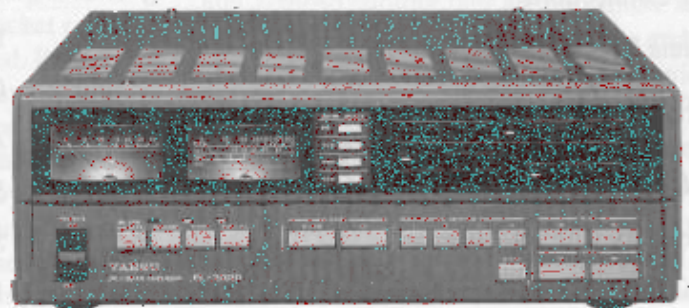

YAESU MUSEN CO., LTD.

C. P. O. BOX 1500
TOKYO, JAPAN

Automatic Tuning QSK Amplifier

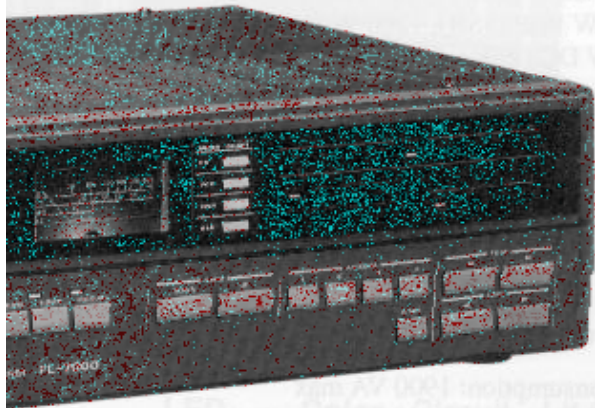

FL-7000 HF Solid State, Automatic Linear Amplifier

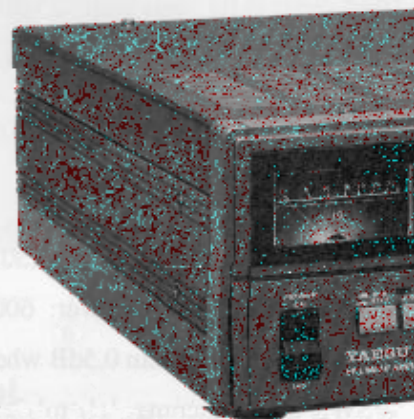

all
ly
o-
IF
*
protective circuitry to avoid distortion of the rf output as well as to protect the components: collector current, driving power from exciter, temperature of amplifier and regulator heatsinks, VSWR at output, push-pull

The FL-7000 is a microprocessor-controlled, solid state linear amplifier with built-in power supply and automatic antenna tuner, providing up to 1.2 kilowatts RF input power on the 160- through 10-meter HF amateur radio bands, including the WARC bands.

FL-7000A(1), FL-7000A, FL-700 and FL-1000. When changing bands, previously stored antenna selection and tuner setting are recalled from lithium-backed memories automatically. Transmission and retuning are not required. When rematching to a new load, the power amplifier section automatically turns off until the antenna has been matched.

Six different parameters in the amplifier, power supply and tuner are simultaneously monitored by the pro-

nating the problems of tube and high voltage component failures. However, should your FL-7000 ever need realignment, it has been designed with every alignment point easily accessible by simply removing the top cover.

To assure optimum performance and safety, please read this manual carefully before connecting the FL-7000 to the power source and your transceiver.

* excluding 10- and 12-meter bands in USA version (may be added upon proof of license).

Specifications

General

Frequency coverage (MHz): 1.8 - 2, 3.5 - 4, 7 - 7.5, 10 - 10.5, 14 - 14.5, 18 - 18.5, 21 - 21.5, and 24.5 - 25, 28 - 30 except in USA version

Collector input power (final transistors):
1200 W PEP (SSB), 1200 W DC (CW),
600 W DC (FSK), 550 W DC carrier (AM)

Continuous Full Power Transmission Period:
(SSB) 100% for 30 min.,
(Full Carrier) 100% for 1 min.

Case size (WHD): 390 x 130 x 400 mm

Weight: 30 kg (66 lb)

Power consumption: 1900 VA max
(@500 W RF output)

Linear Amplifier Section

Excitation power: less than 100 W for 1200 W input

ALC voltage (output) range: 0 to -9V

Spurious radiation: less than -50 dB

Third-order IMD: less than -25 dB

Input/Output impedance: 50 ohms, unbalanced

Automatic Antenna Tuner Section

Impedance matching ranges:

(1.8 - 2 MHz) - 25 to 100 ohms, unbal.

(other amateur bands) 16 to 150 ohms, unbalanced

Maximum feedthrough power: 600 watts

Insertion loss: less than 0.5dB when tuned to match

VSWR after matching: 1:1 to 1.2:1

Accessories

Supplied

Description	Qty	P/N
Coaxial Cable (for Transceiver-to-Linear)	1	T9100980
ALC & PTT Connection Cables with Phono Plugs	2	T9101296
Band Control Cable for FT-757GX(II)	1	T9102337
20A Fuse (for 100-120 VAC operation)	1	Q0000009
10A Fuse (for 200-234 VAC operation)	1	
Long Feet (to allow increased ventilation)	2	R3054620
Foot Pad (for long or short feet)	6	R7054630A

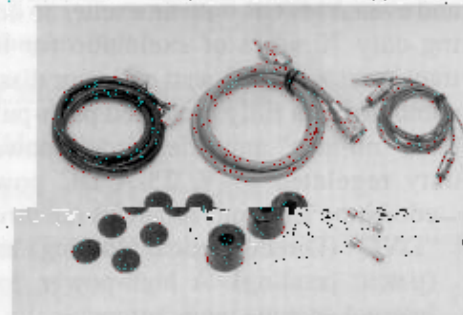

Optional

FAS-1-4R Remote Antenna Selector	D3000198
Band Control Cable for FT-747GX, -767GX, FT-990 or FT-1000	D4000019
Band Control Cable for FT-980	D4000014

Indicators, Switches & Jacks

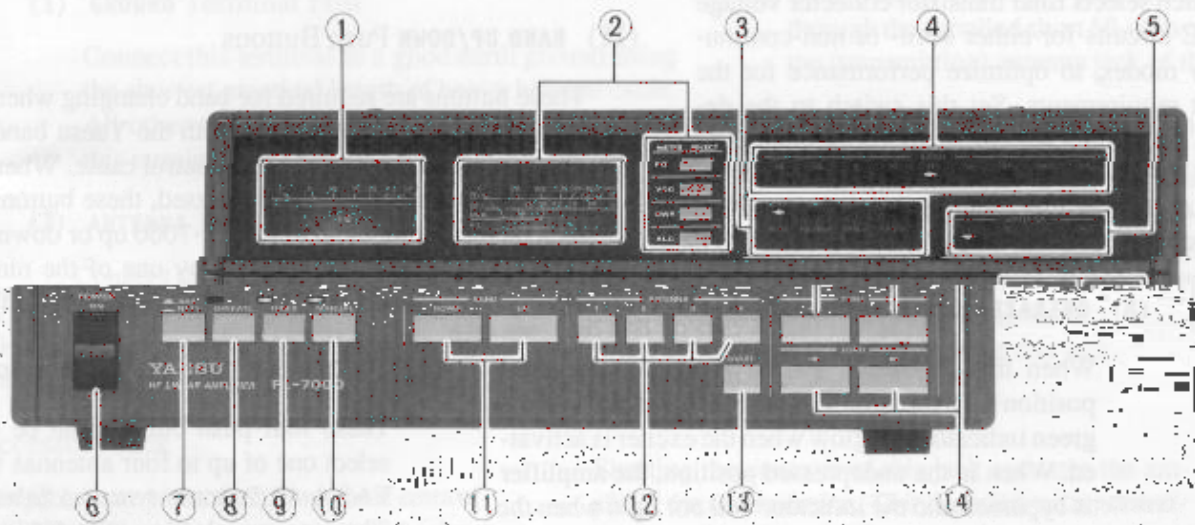

Control Panel

PO Meter

This meter indicates total amplifier collector current, in Amperes.

Multimeter and Selector Switches

This meter indicates PO (Power Output), Vcc (DC collector voltage at final transistors), VSWR (Voltage Standing Wave Ratio) at the antenna jack, or ALC (Automatic Level Control) voltage fed back in the Amplifier to the exciter. The function to be displayed is selected by the corresponding push-button switches to the right of the meter.

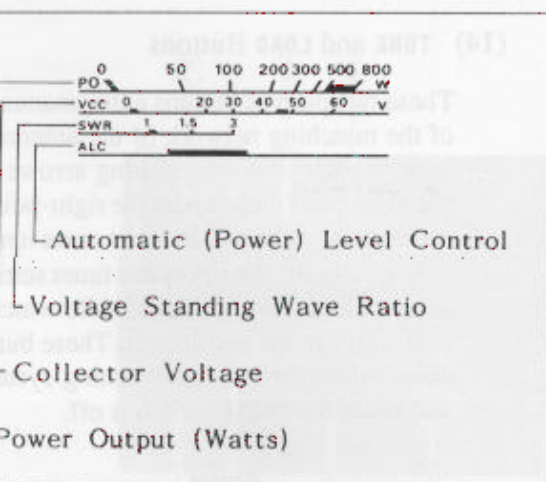

Function Status Indicators

These eight LEDs indicate the operational status of the amplifier, power supply and antenna tuner circuits, as follows:

LED	Color	Circuit	Lit Condition
READY	green	ATU	Antenna is tuned
WAIT	yellow	ATU	Tuner is working
WARNING	red	ATU	SWR is too high
PROTECT	red	all	(see below)
SEND	red	Amp	Transmission
PS TEMP	yellow	PSU	PSU temp is high
FAN1	green	PSU	PSU fan is on low
FAN2	green	Amp	Amp fan is on low

When one of the automatically monitored parameters exceeds safe limits the **PROTECT** indicator flashes while the microprocessor takes defensive action, as described in the "Operation" section.

(4) BAND Indicators

One of these nine green LEDs will be lit to indicate the selected operating band of the amplifier.

(5) ANTENNA Indicators

One of these four green LEDs will be lit to indicate the antenna selected via the optional FAS-1-4R Remote Antenna Selector, if used. Otherwise, these indicators and the corresponding switches may be ignored.

(6) POWER ON/OFF Switch

This is the main power switch. When off (■), the exciter is connected directly to the antenna (No. 1 if the FAS-1-4R is in use). If this switch is turned off while the power supply and amplifier are hot, the **PS TEMP**, **FAN1**, **FAN2** indicators and fans will remain on until the respective units have cooled sufficiently.

From

(1) IC

The
ren

(2) M

This
col
age
AL
fron
disp
but

(3) Fu

The
the
cui

Indicators, Switches & Jacks

(7) **SSB/RTTY** Push Switch

This switch selects final transistor collector voltage and ALC circuits for either semi- or non-continuous-duty modes, to optimize performance for the different requirements. Set this switch to the depressed position (⬇) for semi-continuous-duty modes (RTTY, FM, AMTOR, packet & SSTV). Otherwise it should be in the undepressed position for non-continuous-duty modes (SSB, AM & CW).

(8) **OPERATE** Push Switch and LED

When this 2-position switch is in the depressed position (⬇), the amplifier will be functional and the green indicator will glow when the exciter is activated. When in the undepressed position, the amplifier is bypassed and the indicator will not light when the exciter is activated. See the diagram below. The function of this switch is overridden by the micro-processor if the **PROTECT** indicator is blinking.

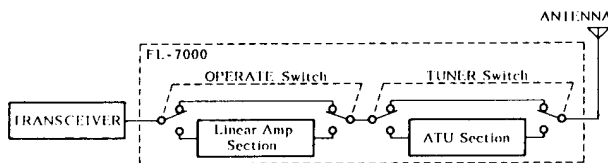

(9) **TUNER** Push Switch and LED

When this 2-position switch is in the depressed position (⬇) the corresponding green indicator is lit and the antenna tuner is in the circuit between the amplifier and the antenna. When in the undepressed position, the antenna tuner is bypassed, and the amplifier connects directly to the antenna. See the diagram above.

(10) **MANUAL** Push Switch and LED

When this 2-position switch is in the depressed position (⬇) the corresponding green indicator is lit and the operating band of the FL-7000 can be selected manually via the **BAND DOWN/UP** buttons. When in the undepressed position the band is selected automatically by the transceiver (FT-980, FT-747GX,

FT-757GX, FT-767GX, FT-990 and FT-1000) via the optional band control cable, if used.

(11) **BAND UP/DOWN** Push Buttons

These buttons are required for band changing when using an exciter not equipped with the Yaesu band control jack and optional band control cable. When the **MANUAL** push switch is depressed, these buttons step the operating band of the FL-7000 up or down. The selected band is indicated by one of the nine green LEDs at the upper right of the front panel.

(12) **ANTENNA 1 ~ 4** Selector Buttons

These four push buttons can be used to manually select one of up to four antennas when the optional FAS-1-4R Remote Antenna Selector is connected. The antenna selection is stored in memory, so once selected and matched on a particular band, the same antenna will be reselected automatically when recalling that band. If the FAS-1-4R is not used, these buttons have no function.

(13) **START** Push Button

This momentary-contact button activates the auto-tune system manually. Normally, when the operating band is changed, the tuner will automatically adjust itself for the same antenna selection and matching impedance set the last time that band was used. Press the **START** button to retune if you are on a different part of the band, or if the SWR is still too high after automatic tuning. Manual restart with this button can be used to force rematching the antenna at any time.

(14) **TUNE** and **LOAD** Buttons

These two pairs of buttons allow manual adjustment of the matching network of the antenna tuner. The buttons under the left-pointing arrows increase capacitance, and those under the right-pointing arrows decrease capacitance. In some cases it may be desirable to “tweak” the automatic tuner settings manually by poking these buttons while watching VSWR indication on the multimeter. These buttons are disabled when the automatic tuning system is active, and when the **TUNER** switch is off.

Rear Panel Connectors

(1) **GROUND** Terminal Post

Connect this terminal to a good earth ground using the shortest practical length of heavy braided cable. All other station equipment should be grounded to this terminal.

(2) **ANTENNA** Jack

Connect this type M (SO-239) jack to the antenna or input jack of the FAS-1-4R using large (RG-8/U or larger) 50-ohm impedance coaxial cable with the mating plug (type M, PL-259).

(6) **INPUT** Jack

This type M (SO-239) jack should be connected through the supplied short 50-ohm coaxial jumper to the (transmitting) antenna jack of the transceiver.

(7) **SSB ALC & RTTY ALC** Controls and **ALC** Jack

These control allows adjustment of the ALC voltage level (output) for non- and semi-continuous-duty modes, provided at the **ALC** phono jack, for control of the exciter. The front panel **SSB/RTTY** switch selects which control sets the level at the jack. Maximum ALC range is 0 to -9 VDC at this jack.

(8) **DTT** Jack

Installation

Unpacking and Inspection

Carefully remove the amplifier from its packing carton and examine it for any signs of visible damage. Check the buttons and switches to ensure nothing has broken loose. If any damage is found, document it thoroughly and notify the shipping company at once. Save the packaging materials for possible use later.

Installation Procedure

The amplifier must be located so that air can circulate freely around the top, bottom and rear of the cabinet. Do not place anything on top of or under the amplifier that might obstruct airflow.

duce full output, and additional drive power will merely be wasted generating heat.

Power Connections

The power supply in the FL-7000 is capable of operation from 100/110/117/200/220 or 234 VAC at 50 or 60 Hz. However, the primary of the power transformer must be wired to match the AC mains voltage you intend to use, as must the amplifier fuse. If you have a choice between two voltage ranges, use the higher voltage to minimize losses in the AC cable and transformer. Make certain that the voltage specification marked on the rear panel of the amplifier matches the AC supply voltage you intend to use. If it does not, remove the top cover of the amplifier and reposition the transformer tap connections as indicated in the diagram below (and on the left side of the chassis).

Important!

Installation

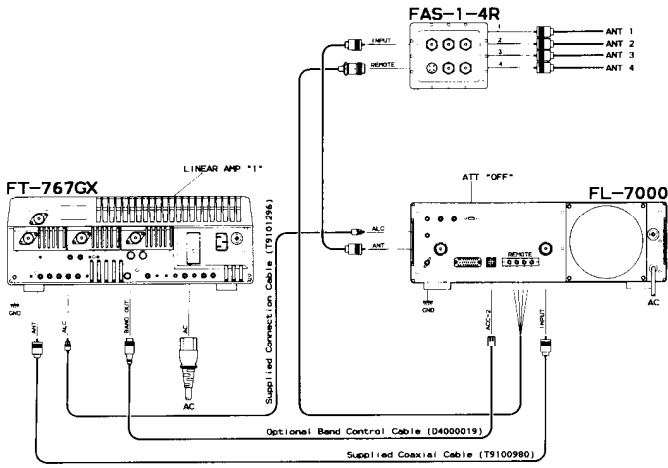

FT-767GX/FL-7000/FAS-1-4R

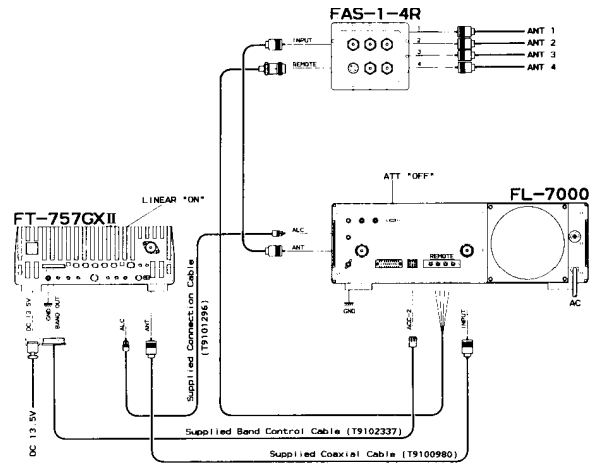

FT-757GXII/FL-7000/FAS-1-4R

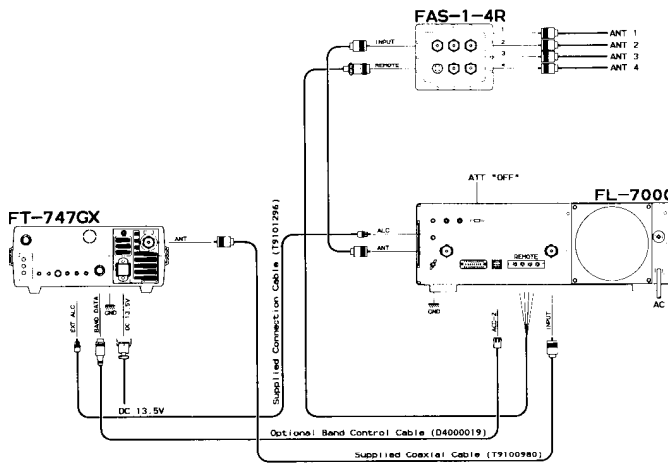

FT-747GX/FL-7000/FAS-1-4R

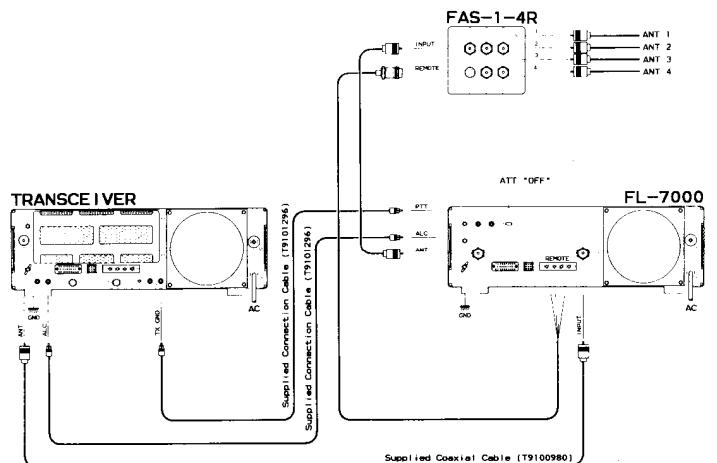

TRANSCEIVER/FL-7000/FAS-1-4R

Operation

Preliminary Checks

Before switching on power, recheck all interconnections as described in the preceding section. Double check the ground and antenna connections, and the ALC connection cable. If using an FT-980, ensure that the **LIN AMP** switch on the rear panel is set to (upper) position 1. If using an FT-757GX(II) or FT-767GX ensure that the **LIN** or **LINEAR** switch is depressed (position 1). The FT-990 and FT-1000 do not require special switch setting on the transceiver, but the **ATT** switch on the back of the FL-7000 must be set to the **ATT** position for the FT-1000.

If using one of the above transceivers *with* a band control cable, band selection and antenna rematching will occur automatically whenever you change bands on the transceiver. In this case, if you are also using the FAS-1-4R with multiple antennas, the antenna last used on each band will also be reselected when that band is recalled on the transceiver. In this case, do not press the **MANUAL** switch unless you specifically want to disable the automatic band and antenna selection functions.

If you are using a transceiver *without* a band control

transmitter. If you normally have your key or keyer paddles plugged into the transceiver you can close the key contacts to transmit (make sure the internal keyer in your transceiver is switched off, if you have one). If you are using an external electronic keyer you will need to short the output for tuning: do not try to tune up with a string of dits or dahs.

Always listen for a short while to make certain that the frequency is clear before keying the transmitter (*you may be required by-law to transmit your callsign at the beginning and end of transmissions*). After initial tuning the FL-7000 will automatically store the tuner settings in memory and recall the stored settings when changing bands, without the need to transmit a carrier again.

First-Time Power-Up & Check-Out

- Set all front panel switches on the FL-7000 to their undepressed (■) positions, except the **VCC** meter select switch (and the **MANUAL** switch if you are not

Operation

Drive Power Check

If this is first-time operation, or whenever using a

- Make sure the **OPERATE** and **TUNER** switches on the FL-7000 are both off.
- Connect a 100-watt dummy load to the FL-7000, if available. If a dummy load is not available, tune the transceiver to a clear frequency (for which your antenna is designed).
- Set the transceiver to CW mode, and preset the **DRIVE** control on the transceiver fully clockwise (maximum).
- If you have the **MANUAL** switch depressed, press the **BAND UP** and **DOWN** keys while observing the band indicators at the upper left of the front panel, to select the same band selected on the transceiver. Otherwise, if a band control cable is used, band selection should be automatic, but you should confirm this by noting

whether the band indicators on the transceiver and the FL-7000 match.

- If you have the optional FAS-1-4R Antenna Selector

using the FAS-1-4R, ignore this step.

- Press the FL-7000 **PO** meter select switch, and while watching the PO scale of the FL-7000 multimeter, briefly key the transmitter.
- If the (indicated) exciter power was above 100 watts, turn the **ATT** switch on the rear panel on. *Never move the **ATT** switch while transmitting.*

Drive power must be at least 50 watts for accurate SWR detection, and 70 to 80 watts for optimum tuner performance. When the FL-7000 power amplifier section is activated, ALC voltage is fed back from the amplifier to the transmitter, to reduce power output to this level. However, much higher drive power to the amplifier will cause the protective circuitry to disable the amplifier (to avoid damage to the input circuits).

WARNING and PROTECT Indications

If the antenna impedance is too far from 50 ohms, or if there is too much reactance in the antenna

- One or both of the power supply or amplifier heat-

minimum SWR point, and the **WARNING** or blinking **PROTECT** indicator will come on after a few minutes, instead of the **READY** indicator. If this happens, press the **PO** button and check the PO scale of the multimeter to ensure that the transmitter is providing at least 70 watts output, and then return to receive.

The **WARNING** lamp indicates that the SWR is too high. This can usually be confirmed during antenna matching, where the SWR meter indication will be above 3:1.

To remedy this situation the antenna or feedline will generally have to be repaired or replaced with one having an impedance closer to 50 ohms on the selected band. However, if the SWR indication is close to 3:1, it may be possible to obtain a better match by restarting the tuner: first recheck the antenna connections, and that the transmitter is set for at least 70 watts output. Then repeat the antenna matching procedure. If the **WARNING** lamp is still on after tuning, rework or replace the antenna.

The blinking **PROTECT** lamp indicates one or more of the following potentially dangerous conditions:

ceeded 80 watts, despite ALC fed back from the FL-7000 to control excitation.

- ALC voltage is more negative than -9V.
- More than 50 watts of imbalance has occurred between the two sections of the power amplifier.

When the microprocessor senses one of these conditions, it bypasses the power amplifier. The only way to reset from the protected state is to turn the FL-7000 **POWER** switch off. If overheating caused the protector to trip, the **PROTECT** lamp will flash again, and the FL-7000 cannot be used until it cools.

If overdrive or excessive ALC voltage caused the protector to trip, check the ALC connection to the transceiver, and that the exciter power level is not more than 100 watts (set the **ATT** switch on if it is).

Imbalance of the power amplifier indicates probable damage to the Combiner or PA sections of the FL-7000. The protection afforded by this feature lessens the chance of damage to the final transistors.

Operation

Initial Antenna Matching Procedure

- Press the **SWR** meter select switch, and then briefly key the transmitter while watching the SWR scale of the multimeter, and note the indication. (SWR calculation is automatic, so no full-scale presetting is necessary).
- If the SWR indication was above 1.5:1 (but below 3:1), activate the ATU (Antenna Tuning Unit) to retune, as follows:
 - (a) Press the **TUNER** switch.
 - (b) Key the transmitter.
 - (c) Press the **START** button.
- After a minute or so, the **READY** light will come on if the tuner is able to match the antenna. If not, **WARNING** or **PROTECT** will come on. In any case, stop transmitting as soon as the **WAIT** light turns off (but not before).
- If **WARNING** or **PROTECT** came on, see the box on the previous page.
- If the **READY** light is on after tuning, press the **PO** meter select switch and the **OPERATE** switch. The FL-7000 is now ready for operation, described in the next section. However, for first time operation (or when using a new transceiver), perform the next two steps

once the antenna has been matched the first time, back off the exciter **DRIVE**.

For *SSB and CW* operation, make sure to adjust the **MIC** gain and/or **DRIVE** controls on the transceiver for proper ALC indication on the transceiver ALC meter, as described in the transceiver manual. Generally, for SSB, ALC meter indication should not deflect beyond a certain ALC limit (the ALC zone on the transceiver's meter) on voice peaks; while for CW, the ALC indication should be just enough to cause slight meter deflection. Higher ALC levels are likely to produce distortion or key clicks, without additional power. The PO meter selection on the FL-7000 should indicate 500 watts at full power, as set by the **SSB ALC** control on the rear panel.

After setting the **DRIVE** or **MIC** gain as indicated in the transceiver manual, press the **ALC** meter select switch on the FL-7000, and confirm that the indication is within the ALC zone on the linear's multimeter.

For *FM, SSTV, RTTY, AMTOR or packet*, make sure the **SSB/RTTY** switch on the front panel of the FL-7000 is depressed, and adjust the **DRIVE** control on the transceiver so that the PO meter on the FL-7000 indicates 250 watts (maximum) while transmitting, as set by the **RTTY ALC** control on the rear panel. This is a safe level that will not cause overheating during continuous operation for extended periods.

For *AM* operation, adjust the **DRIVE** control on the transceiver so that the PO meter on the FL-7000 does not exceed 100 watts when transmitting a carrier (this

- Make sure the **SSB/RTTY** switch on the front panel is set to the undepressed (SSB) position, and locate the **SSB ALC** potentiometer on the rear panel. Key the transmitter (in CW mode), and adjust this control, if necessary, for 500 watts on the PO meter. If on the 160m band, adjust the **ALC** control for 20 Amperes on the IC meter.

more than about one width of the meter needle.

During transmissions (in any mode), the **PS TEMP** and **FAN** indicator LEDs on the FL-7000 will come on as the heatsink temperatures rise. This is normal. However, if you push the amplifier too hard, with long transmissions at full power, the **PROTECT** function will take over and disable the amplifier, in which case it will shut itself down and require toggling the **POWER** switch to reset the protection circuitry (after cooling).

- Press the **SSB/RTTY** switch (to the RTTY position), and locate the **RTTY ALC** potentiometer on the rear panel. Key the transmitter (again in CW mode), and adjust this control for 250 watts on the PO meter. This **ALC** control allows the amplifier to operate at higher efficiency when run at reduced power output, as is needed for semi-continuous-duty operation.

Manual Tweaking and Retuning

During normal amplifier operation, the SWR detection circuitry senses the full output power of the amplifier, and indicates the resulting SWR on the multimeter when the **SWR** button is pressed. After automatic tuning, if you believe you can improve the match of the tuner further, use the **TUNE** and **LOAD** arrow keys to change the capacitor settings while watching the SWR meter closely. This can be done at full power with the amplifier section of the FL-7000.

Linear Amplifier Operation

Although continuous full exciter power is required for accurate SWR measurement and antenna matching

if you allow the SWR indication to exceed 2:1, the

Operation

microprocessor will automatically disable the **TUNE** and **LOAD** keys, shut off the amplifier section, and attempt to rematch automatically. If this happens, *keep the carrier on until the tuner finishes (READY lights).*

Similarly, if you tune to a different part of the same band, the ATU will sense the SWR when you transmit, and will automatically attempt to rematch the antenna if the SWR exceeds 2:1. When this happens, keep the transmitter keyed with a steady carrier (in SSB, you can hum or whistle a steady note) until **READY** lights.

If you change frequency enough to cause a slight rise in SWR (less than 2:1), you can press the **START** key while transmitting a steady carrier to force automatic retuning, or you can use the **TUNE** and **LOAD** keys (gingerly), if you wish, to dip the SWR again.

When rematching the antenna, manually or automatically, remember: always watch the SWR meter, key the transmitter and apply a steady carrier. Bear in mind that the ATU requires 50 to 80 watts steady drive to tune properly, and that the power amplifier section of the FL-7000 is automatically bypassed by the ATU while it is tuning.

Band Changing

When new, the FL-7000 must be set up as in the previous section for each band. If you are not using a band control cable and one of the Yaesu transceivers noted at the beginning of this chapter, you must remember to change the band selected on the FL-7000 whenever the transceiver band is changed. When changing bands, the microprocessor will automatically recall the

ATU settings last used on that band. Also, if the optional FAS-1-4R is connected with multiple antennas, the last antenna selected on a band will be recalled when returning to that band. If the FAS-1-4R is not being used, remember to reconnect the antenna last used on a band when it is recalled.

Press the **SWR** button to check SWR when you change bands, to make certain that the memorized settings of the ATU are correct for the antenna and frequency of operation. If the SWR is high, key the transmitter and press **START** to rematch.

Operating Precautions

Summarized below are some precautions to adhere to in order to ensure long life and trouble-free operation with the FL-7000:

- Do not transmit after changing bands until the **READY** indicator comes on.
- Do not transmit when turning the **POWER** switch or the (transceiver) ATU switch on or off.
- When changing bands, always make certain that the FL-7000 is set for the same band as the transceiver before transmitting, and that the proper antenna is connected. If using the FAS-1-4R, remember that Antenna 1 is automatically selected when the FL-7000 is switched off.
- Reduce drive power or shorten transmissions if the **PS TEMP** or **FAN** indicators come on.

FL-7000 Microprocessor Resetting

Under certain conditions, one or both of the microprocessors in the FL-7000 can malfunction, causing the front panel LEDs to light at odd times or the **START** switches to be disabled. If this occurs, the microprocessor(s) should be reset by one or both of

If the **START** buttons is disabled and the **READY**, **WAIT** and **WARNING** LEDs appear to be malfunctioning, reset switch S9201.

To reset these switches, first turn the **POWER** switch off, and then set the reset switch(es) off. Then turn the **POWER** back on, followed by the reset switch(es).

If the **BAND** and **ANTENNA** LEDs and the **OPERATE** and **PROTECT** LEDs appear to be malfunctioning,

The locations are S6002 and S9201 are indicated

Alignment

Each FL-7000 is carefully aligned at the factory, so realignment should not be necessary unless a major component failure occurs. Under no circumstances should realignment be attempted without the proper test equipment, and unless operation of the FL-7000 is fully understood, the malfunction carefully analyzed, and the fault definitely determined to be caused by misalignment. Sudden difficulties are almost always

Test Equipment Required

- HF Transceiver: FT-747GX, FT-757GX, FT-767GX, FT-980, FT-990, FT-1000 or equivalent, providing 90 to 120 watts RF excitation in CW and SSB modes on 1.910 and 14.00 MHz.
- DC Voltmeter: with 50-V DC scale.

Alignment

Connect the 1-kW dummy load and in-line RF wattmeter to the antenna jack on the rear panel for all alignment steps.

For those steps that call for transmitter activation, key the transmitter only after all controls have been set and test equipment connected, and then return to receive immediately after taking the reading or making the called-for adjustment.

Remember, although the DC supply voltage is not likely to cause injury, the RF voltage developed by the power amplifier can still be lethal.

Before connecting the FL-7000 to AC power, remove the top cover and confirm that the power transformer primary taps are set correctly for the AC voltage to be supplied during alignment, as shown on page 6.

Refer to the photograph below for locations of the alignment points referred to in the alignment procedures. Adjustment points referred to are prefixed as follows:

VR = trimmer potentiometer

TC = trimmer capacitor

TP = terminal post (test point)

The word "ammeter" in the alignment procedures refers to the multi-function (right-hand) meter on the FL-7000, while "ammeter" refers to the (left-hand) Collector Current meter on the FL-7000. "Test ammeter" refers to the external test equipment by that name. "In-line wattmeter" refers to the external wattmeter connected between the FL-7000 antenna jack and the dummy load(s).

Note!

*Some adjustments of automatic sensing thresholds may trigger their respective functions before alignment can be made. If this occurs, reset the trimmer and repeat the procedure. In those cases where the **PROTECT** thresholds are set, the **POWER** switch must be turned off and on.*

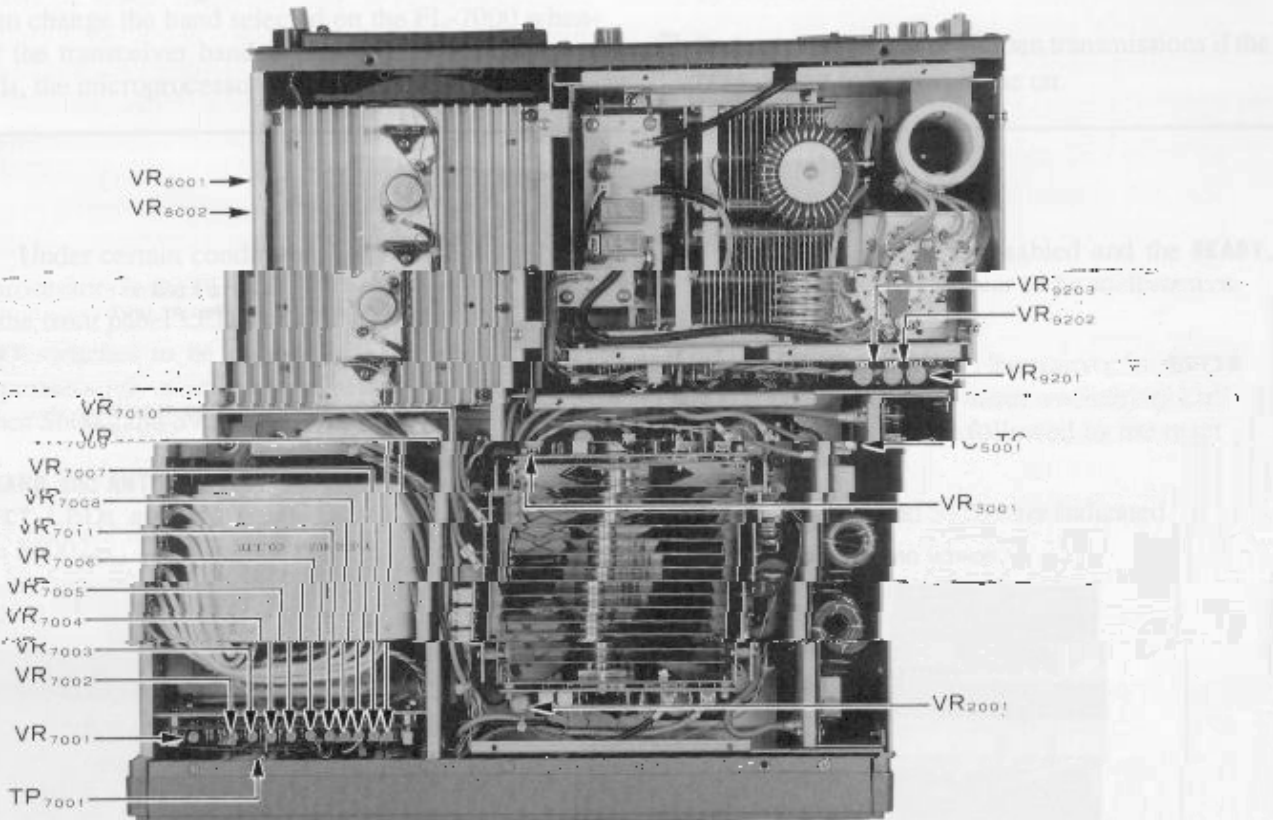

Alignment

Alignment Procedures

VCC Setting & Meter Calibration

- Connect the DC voltmeter (50-V scale) to the **VCC** terminal on the PS Unit, and press the **VCC** switch on the front panel.

- Adjust VR7010 on the Protector Unit for an indication of 47V on the front panel multimeter (corresponding to the 300-W mark on the PO scale).
- Press the **SSB/RTTY** button to select RTTY, and adjust VR8003 on the PS Unit for 32V on the voltmeter.

Overcurrent Protector

- Set the **SSB/RTTY** switch on the front panel to the SSB position.
- Mark the current position of the **SSB ALC** potentiometer on the rear panel (so that it can be reset to this position after alignment), and then turn the potentiometer fully clockwise.
- Press the **OPERATE** button and adjust VR7001 on the Protector Unit so that the ammeter (front panel meter at the left) is just at the threshold point where it begins to deflect (without transmitting).
- Set the transceiver and amplifier to 14.000 MHz, CW mode, and adjust the excitation for 500W output from the linear. Adjust VR7011 on the Protector Unit for an indication of 20 A on the front panel ammeter.
- Retune the equipment to 1.910 MHz, key the transmitter and adjust the **SSB ALC** potentiometer for 27 A on the ammeter.
- With the setup of the last step, key the transmitter and adjust VR8001 on the PS Unit very gradually so that the **PROTECT** indicator just starts to blink (the amplifier will shut down). Turn the **POWER** switch off and back on to reset.
- Return the **SSB ALC** potentiometer to the original (marked) position.

Idling Current

- Temporarily disconnect the wire from the **VCC** terminal on the PS Unit to the **VCC** terminal on the PA-1 Unit, and connect the test ammeter (set for 1 A f/s) in this line, '+' to the PS Unit and '-' to the PA-1 Unit.

- Set the transceiver and FL-7000 to 14.000 MHz SSB mode, and set the **MIC** gain control on the transceiver fully counterclockwise (no drive). With the **OPERATE** button depressed, key the transmitter, *wait sixty seconds*, and then adjust VR2001 on the PA-1 Unit for 100 to 150 mA on the test ammeter.

CM Coupler Balance

- With the transceiver and FL-7000 set to 14.000 MHz, CW mode, set the **OPERATE** and **SWR** switches to the depressed position, and the **TUNER** switch to the un-depressed (off) position.
- Key the transmitter, and with full output power, adjust TC5001 on the LPF Unit for minimum deflection on the multimeter (indicating SWR).

ALC Calibration and Setting

- With the transceiver and FL-7000 set to 14.000 MHz, USB mode, set the **OPERATE** and **ALC** switches to the depressed position, and the **TUNER** switch to the un-depressed (off) position.
- Apply the +9V DC voltage reference to TP7001 on the Protector Unit.
- With minimum excitation (**MIC** gain fully counterclockwise), adjust VR7008 on the Protector Unit so that the FL-7000 multimeter deflects exactly to the right edge of the ALC zone.
- Now adjust VR7005 on the Protector Unit very gradually so that the **PROTECT** indicator just starts to blink, and the amplifier shuts down.
- Return to receive, remove the 9V reference, and turn the FL-7000 **POWER** switch off and back on to reset.
- Switch the transceiver to CW mode, and set the transceiver drive control for full power. Key the transmitter and adjust VR7002 for 500 W on the in-line wattmeter.
- Install the second 50-ohm dummy load in parallel with the first, to provide a 25-ohm load. Key the transmitter and adjust VR7003 for 300W on the in-line wattmeter.

SWR Metering

- With the transceiver and FL-7000 set to 14.000 MHz, CW mode, set the **OPERATE** and **SWR** switches to the

Alignment

depressed position, and the **TUNER** switch to the undeepressed (■) position.

- Connect the 16.5-ohm dummy load (or three 50-ohm loads in parallel) to the antenna jack with the in-line wattmeter.
- Apply maximum CW excitation from the transmitter, and adjust VR7006 on the Protector Unit for minimum deflection on the FL-7000 multimeter (showing SWR).
- Adjust VR7009 on the Protector Unit for an SWR indication of exactly '3' on the multimeter.

SWR Protection Calibration

- With the equipment set up and connected as in the first two steps of the previous procedure, apply maximum excitation and adjust VR7004 on the Protector Unit very gradually until the **PROTECT** indicator blinks and the amplifier shuts down. Turn the **POWER** switch off and on to reset.

PO Meter Calibration

- With the transceiver and FL-7000 set to 14.000 MHz, CW mode, set the **OPERATE** and **PO** switches to the

depressed position, and the **TUNER** switch to the undeepressed (■) position.

- Connect one 50-ohm dummy load with the in-line wattmeter to the antenna jack. Key the transmitter and adjust the exciter drive for 500 W output on the in-line wattmeter.
- Key the transmitter and adjust VR7007 on the Protector Unit for 500 W indication on the PO scale of the FL-7000 multimeter.

ATU Sensitivity

- With the transceiver and FL-7000 set to 14.000 MHz, CW mode, set the **TUNER** and **SWR** switches to the depressed position, and the **OPERATE** switch to the undeepressed (■) position.
- With the 50-ohm dummy load and in-line wattmeter connected to the antenna jack, apply maximum excitation and manually tune the FL-7000 **LOAD** and **TUNE** keys for 1:1 SWR on the multimeter.
- Replace the 50-ohm dummy load with 25 ohms (two 50's in parallel). Then key the transmitter and adjust VR9203, if necessary, so the **WAIT** indicator comes on (the ATU starts automatic tuning).

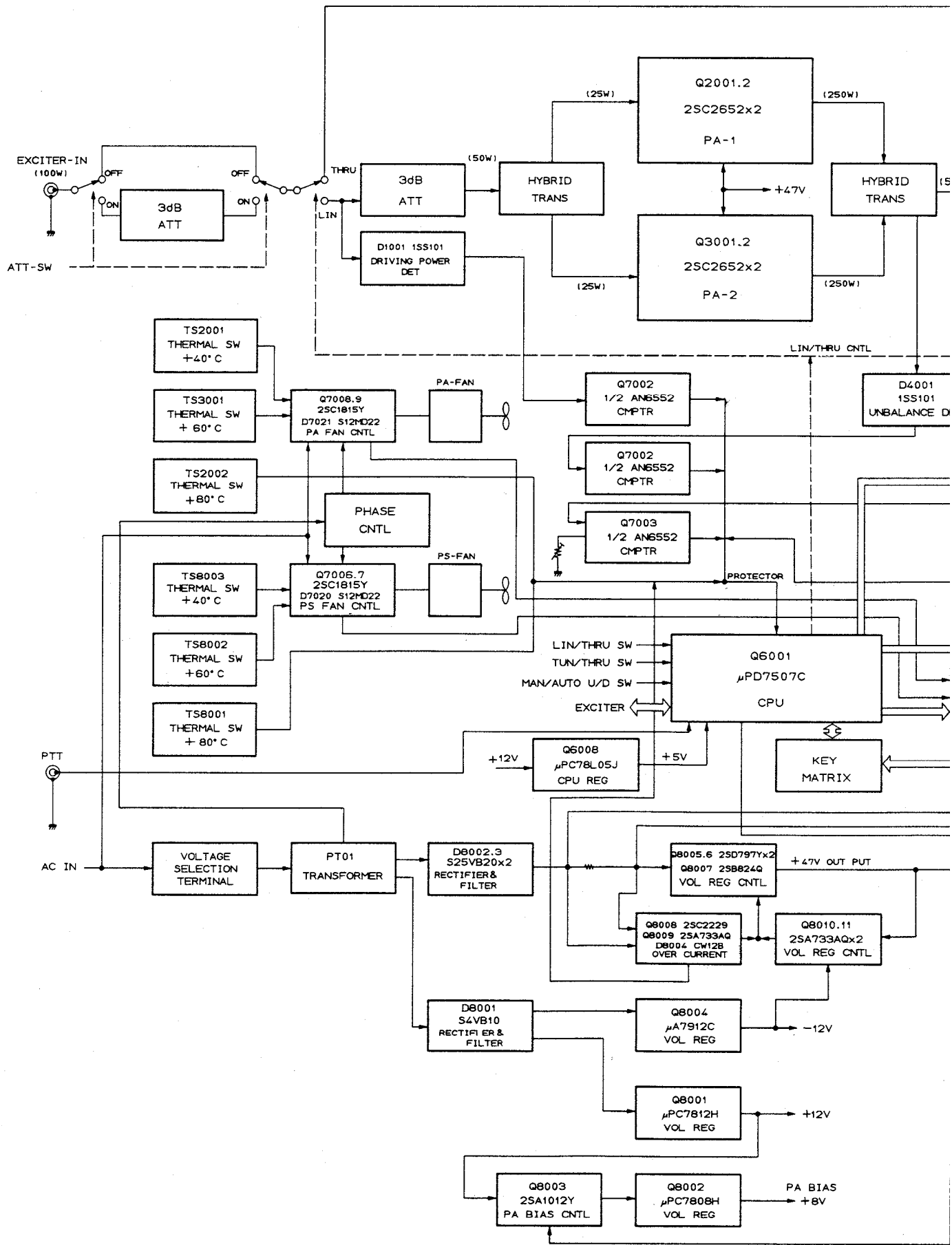

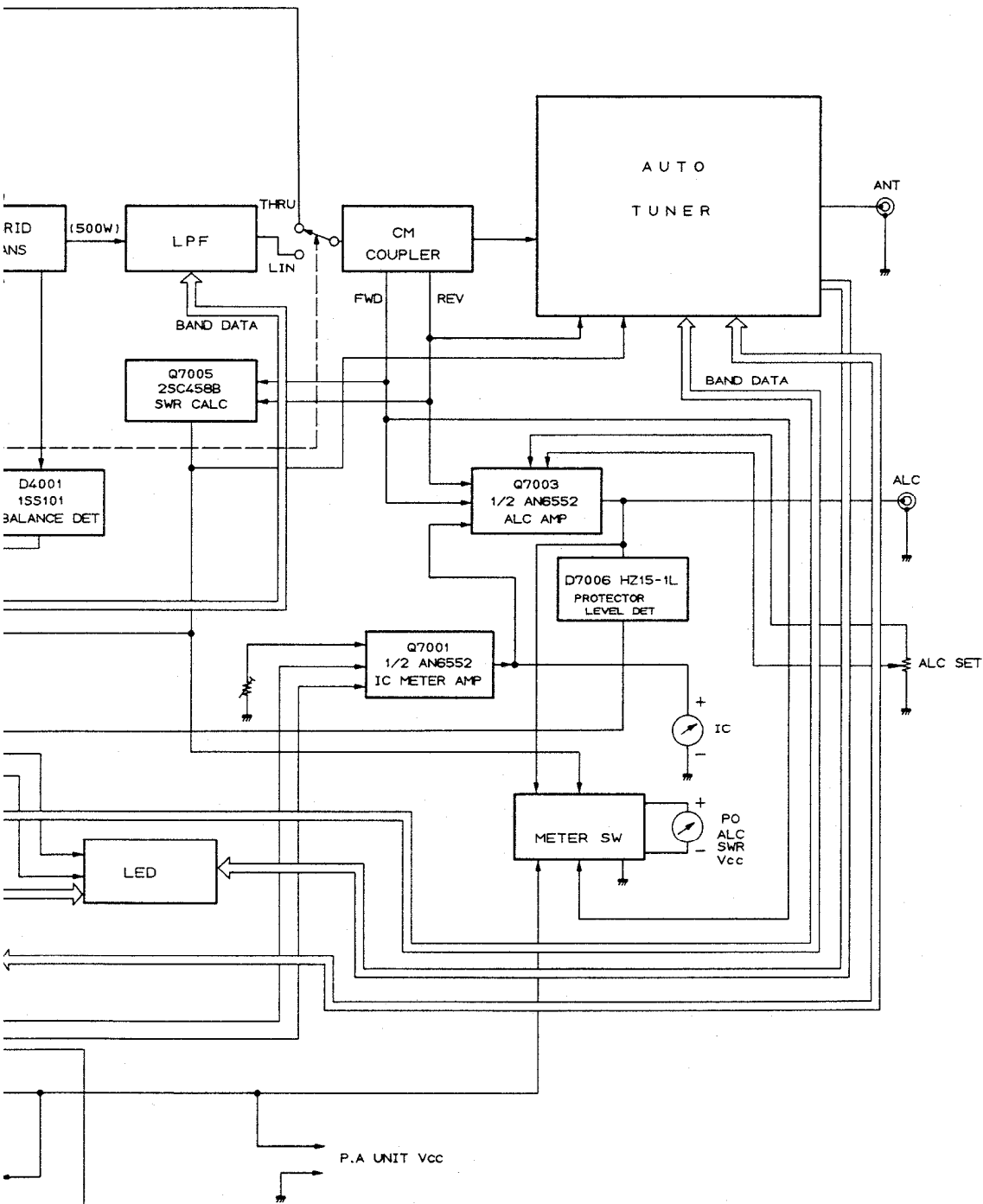

FL-7000
BLOCK DIAGRAM

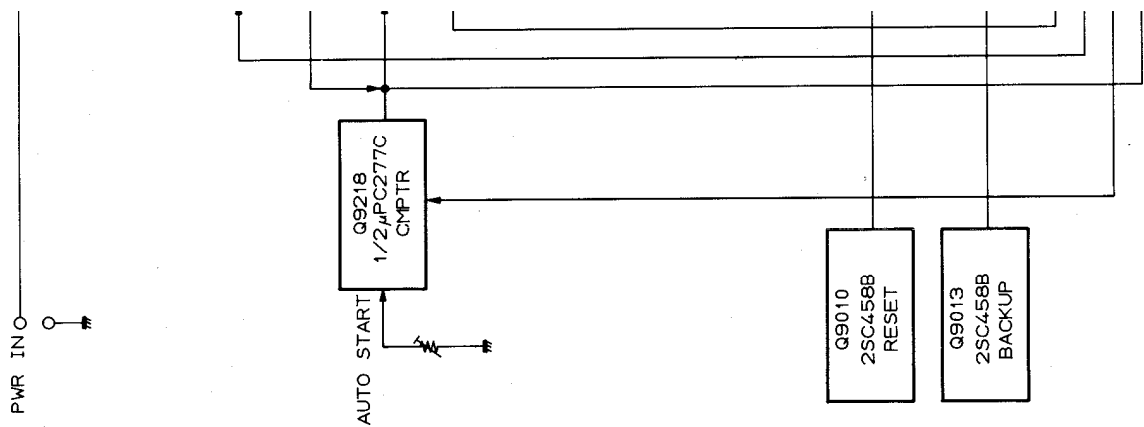
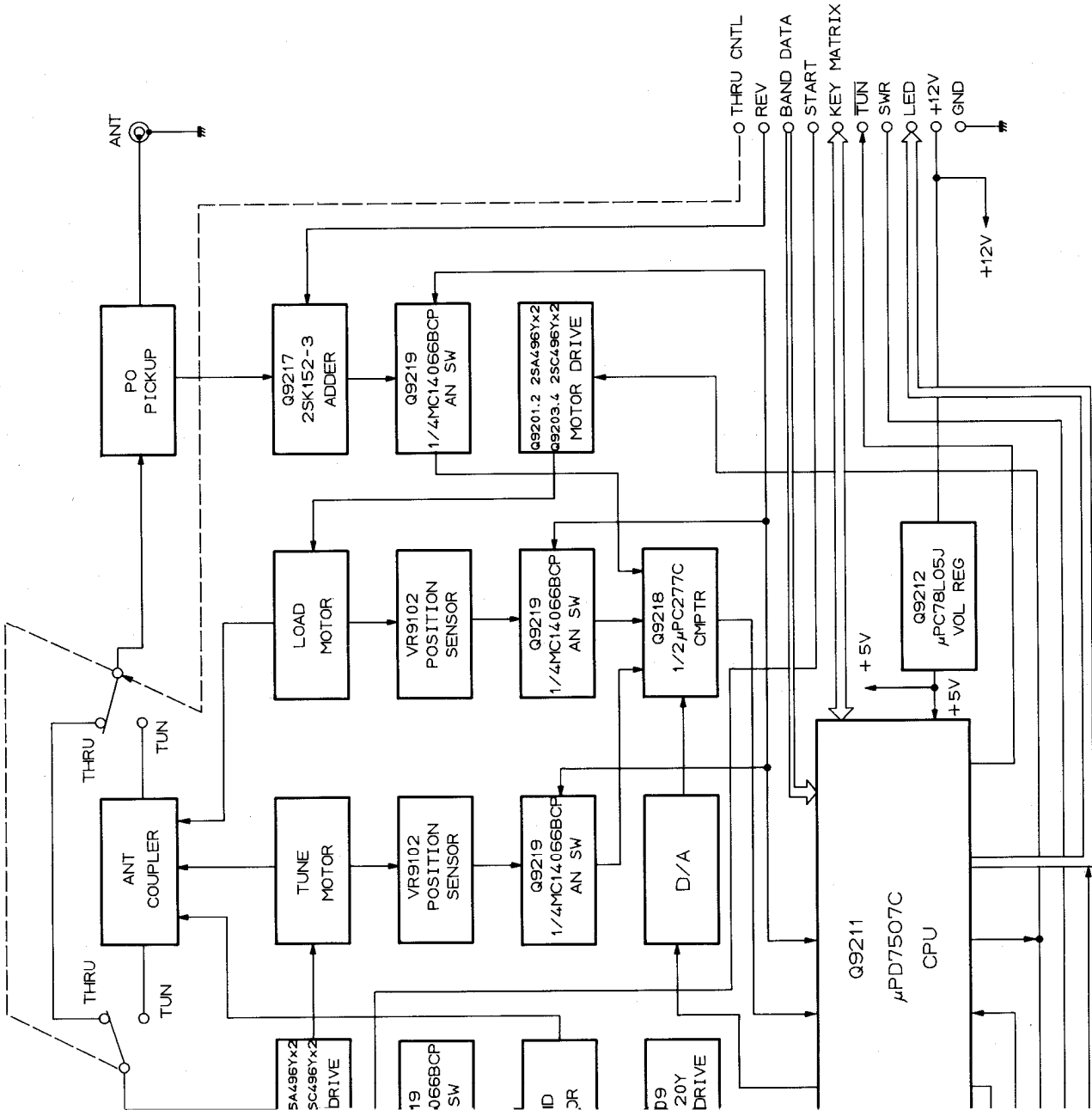

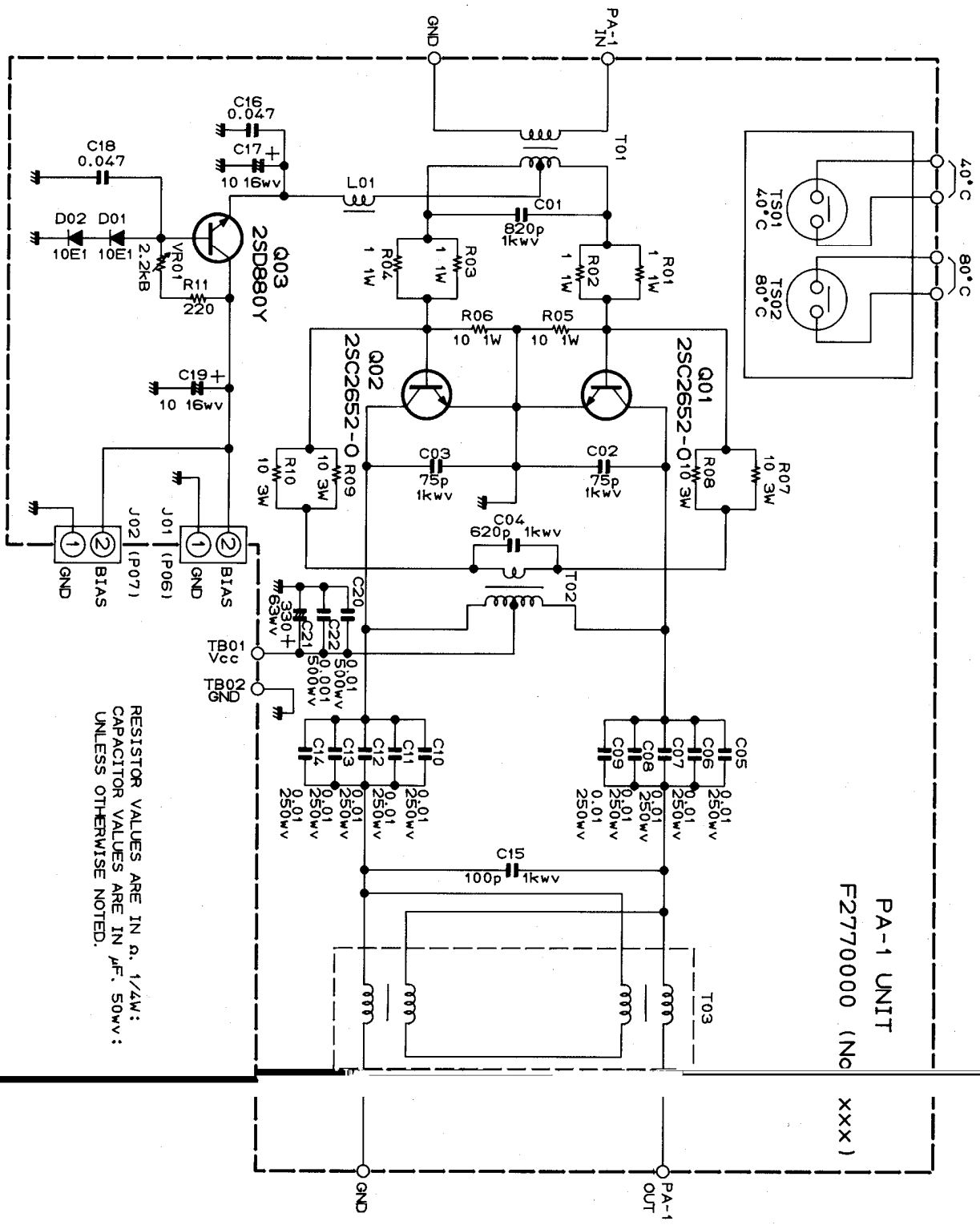

RESISTOR VALUES ARE IN Ω, 1/4W;
 CAPACITOR VALUES ARE IN μF, 50WV;
 UNLESS OTHERWISE NOTED.

PA-1 UNIT
 F2770000 (No
 XXX)

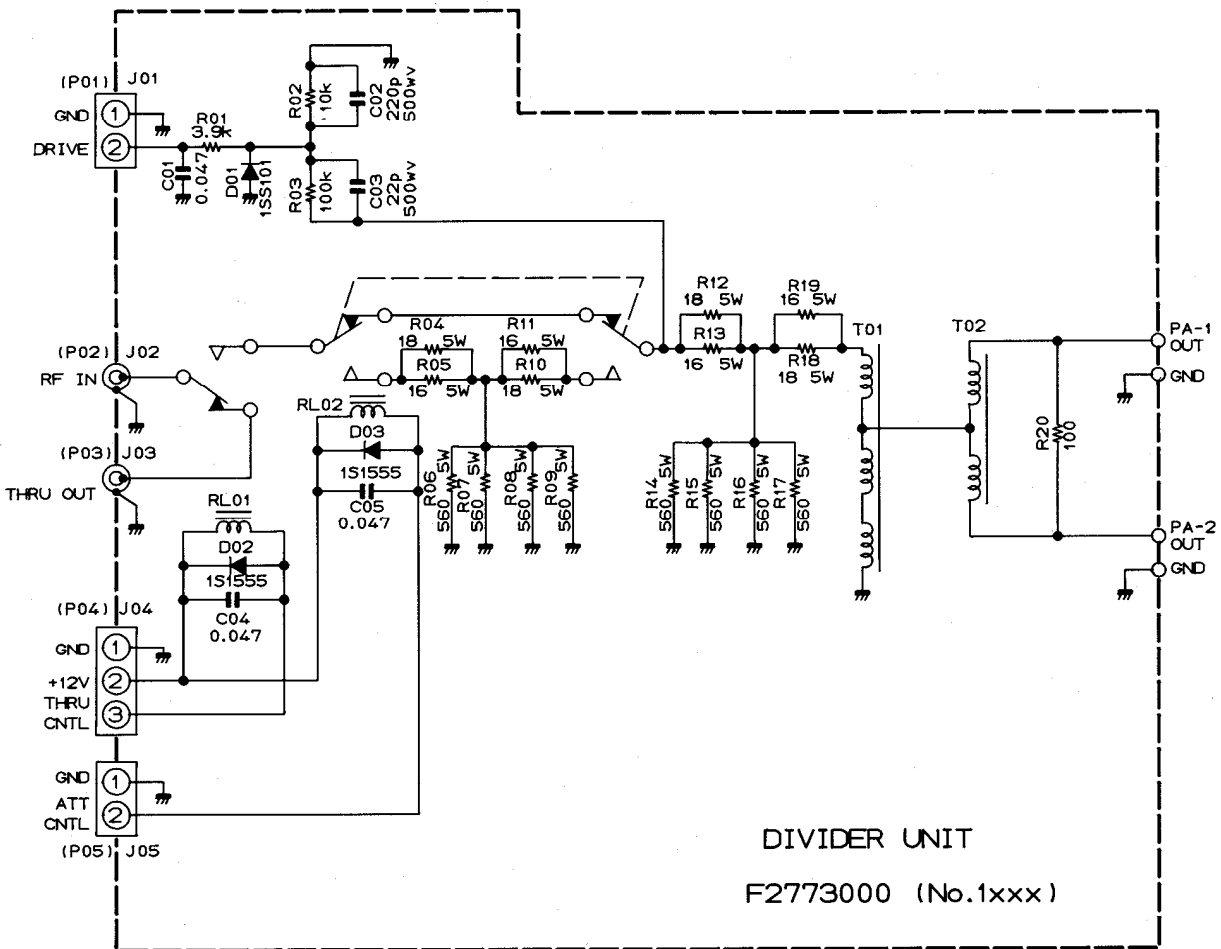

RESISTOR VALUES ARE IN Ω , 1/4W:
CAPACITOR VALUES ARE IN μ F, 50wv:
UNLESS OTHERWISE NOTED.

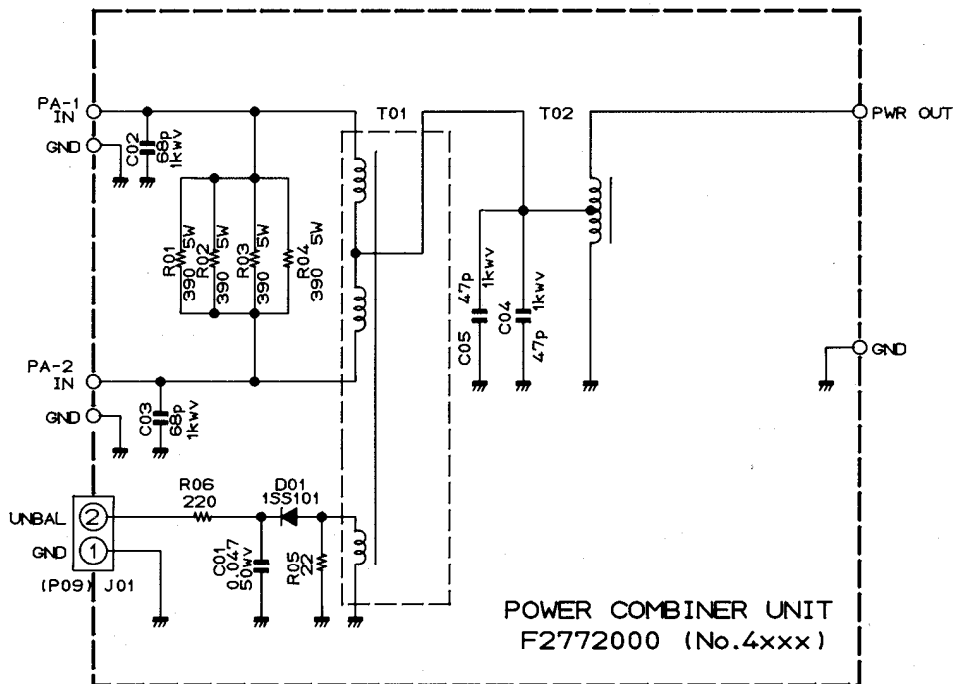

RESISTOR VALUES ARE IN Ω , 1/4W:
CAPACITOR VALUES ARE IN μ F.
UNLESS OTHERWISE NOTED.

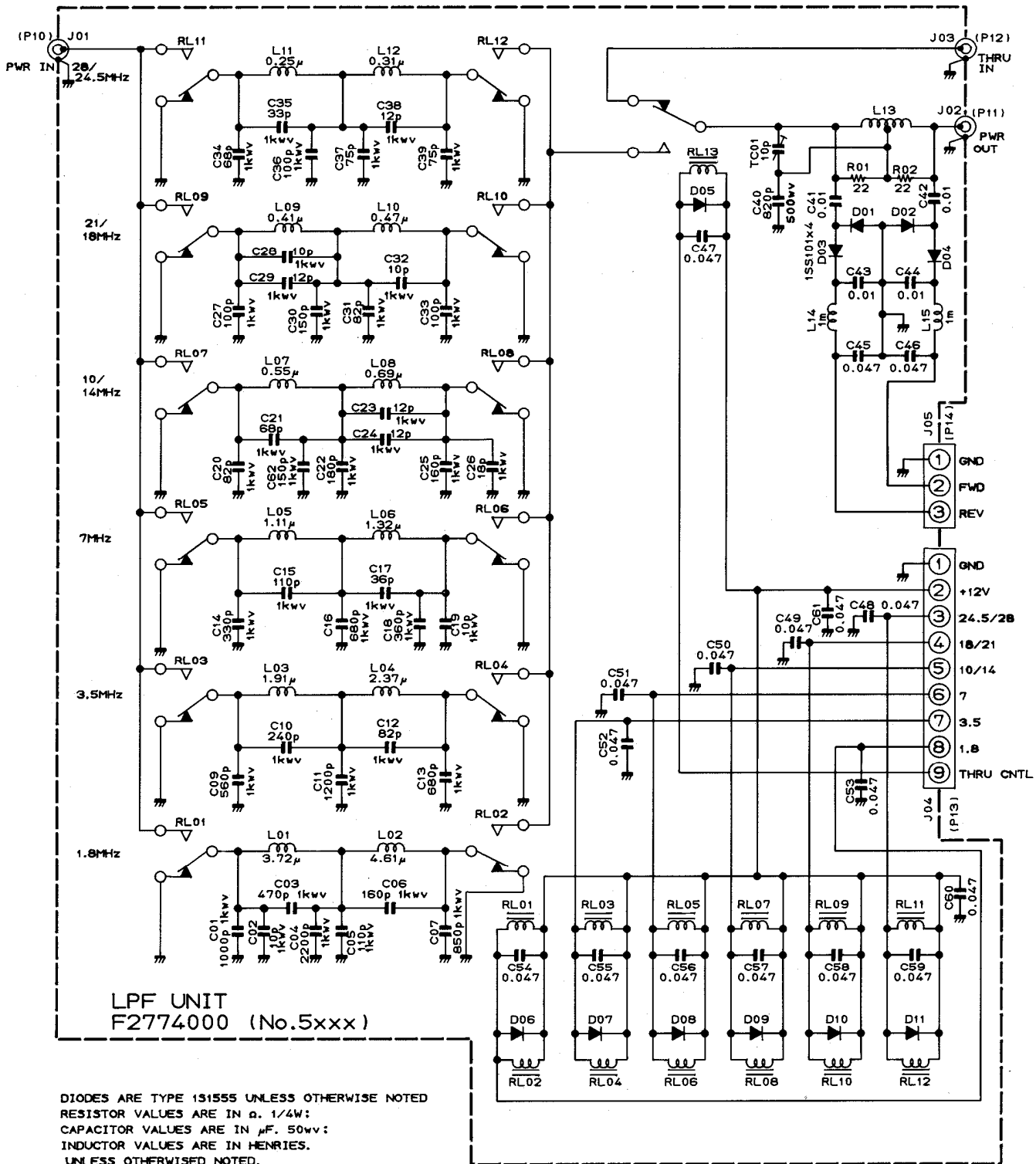

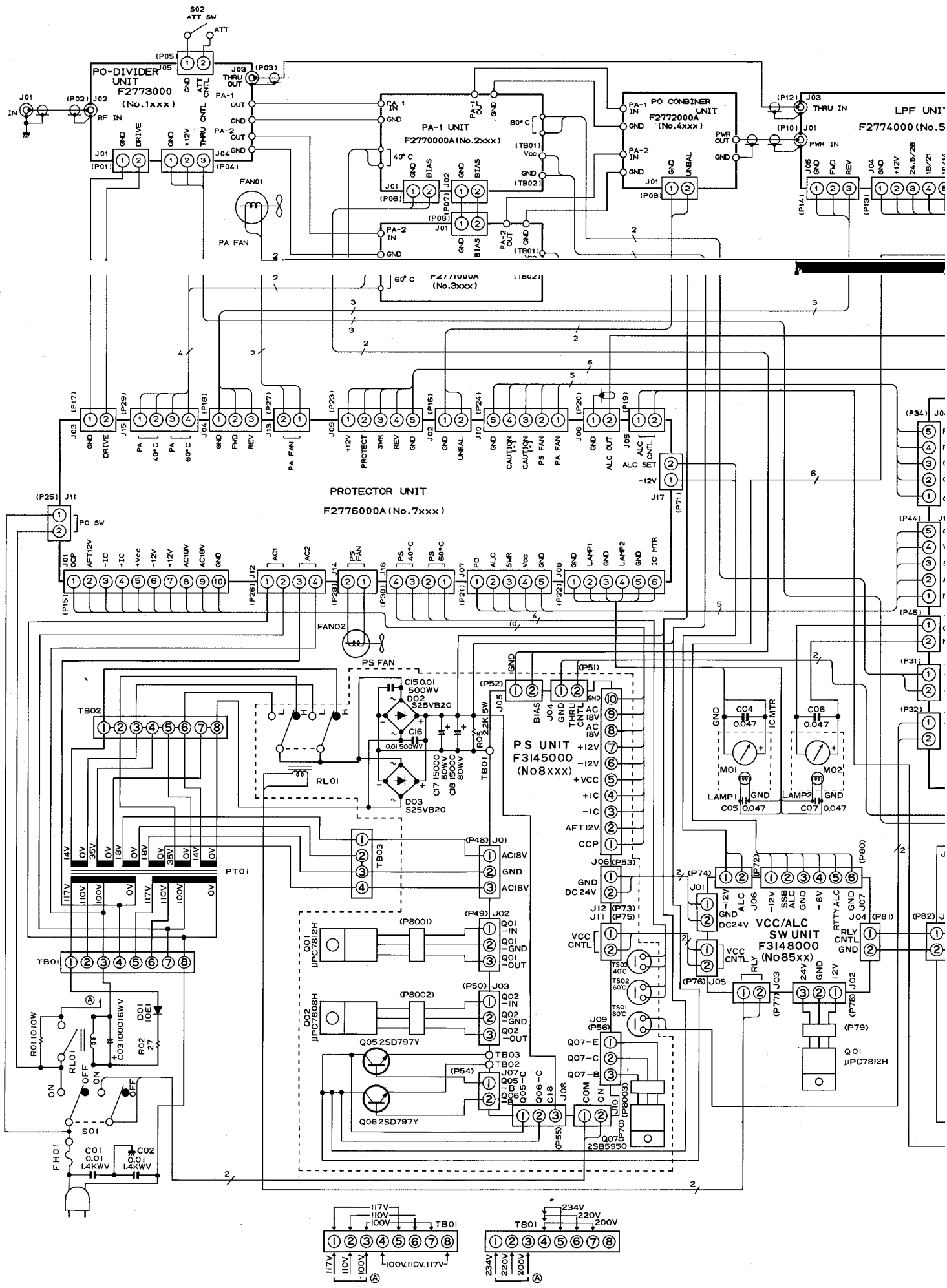

502 ATT SW

PO-DIVIDER UNIT
F2773000
(No. 1xxx)

PA-1 UNIT
F2770000A (No. 2xxx)

PO COMBINER UNIT
F2772000A
(No. 4xxx)

LPF UNIT
F2774000 (No. 5)

PROTECTOR UNIT
F2776000A (No. 7xxx)

P.S. UNIT
F3145000
(No 8xxx)

VCC/ALC SW UNIT
F3148000
(No 85xx)

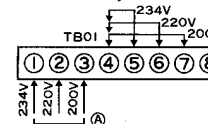
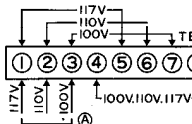

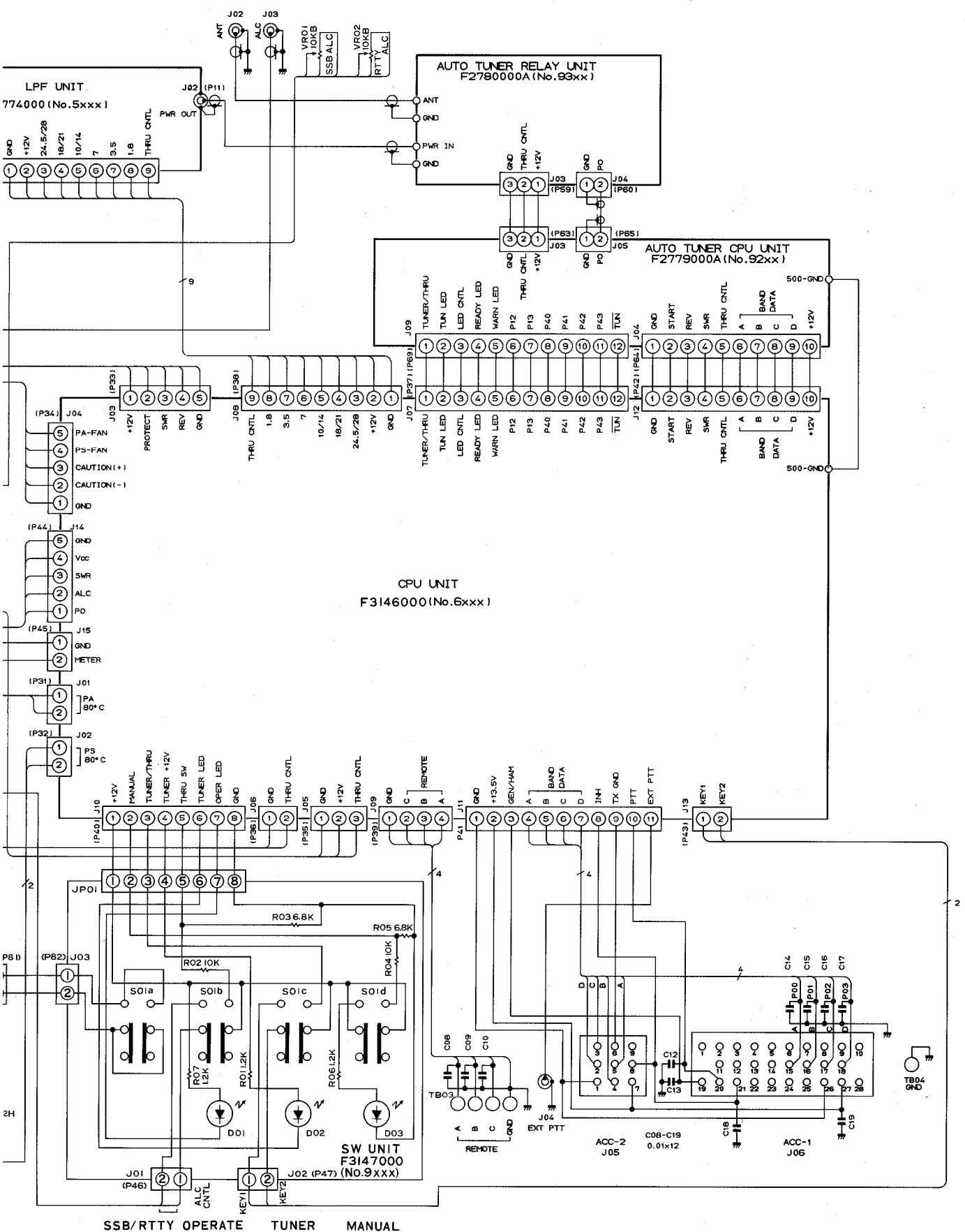

SSB/RTTY OPERATE TUNER MANUAL

RESISTOR VALUES ARE IN Ω , $\frac{1}{4}$ W;
 CAPACITOR VALUES ARE IN μ F, 50WV;
 INDUCTOR VALUES ARE IN H
 UNLESS OTHERWISE NOTED.

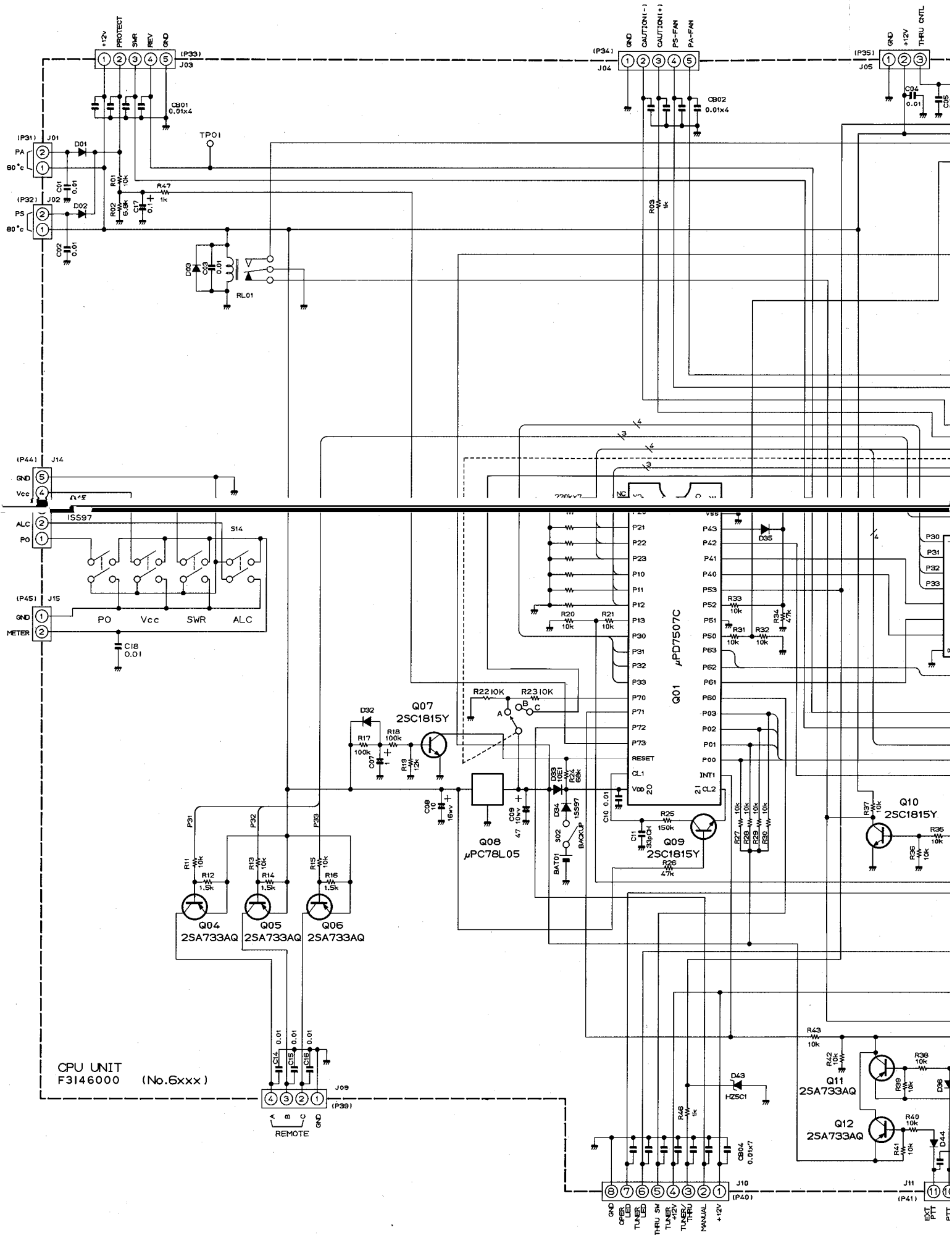

CPU UNIT
F3146000 (No. 6xxx)

Q01 μ PD7507C

Q07 2SC1815Y

Q08 μ PC78L05

Q09 2SC1815Y

Q10 2SC1815Y

Q04 2SA733AQ

Q05 2SA733AQ

Q06 2SA733AQ

Q11 2SA733AQ

Q12 2SA733AQ

80°C

80°C

ALC

METER

EXT PTT

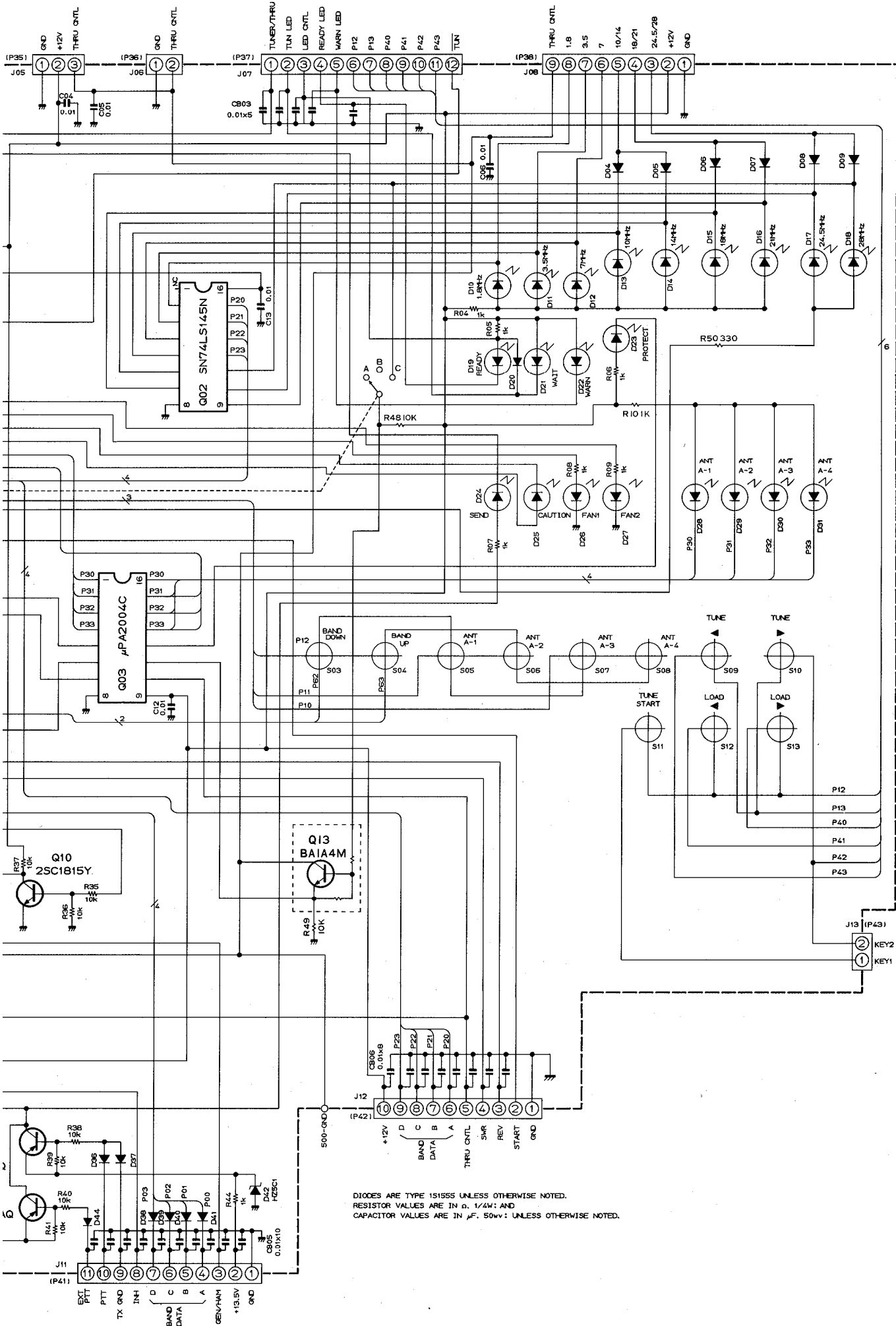

DIODES ARE TYPE 1S1555 UNLESS OTHERWISE NOTED.
 RESISTOR VALUES ARE IN Ω , $\frac{1}{4}\Omega$; AND
 CAPACITOR VALUES ARE IN μ F, 50V; UNLESS OTHERWISE NOTED.

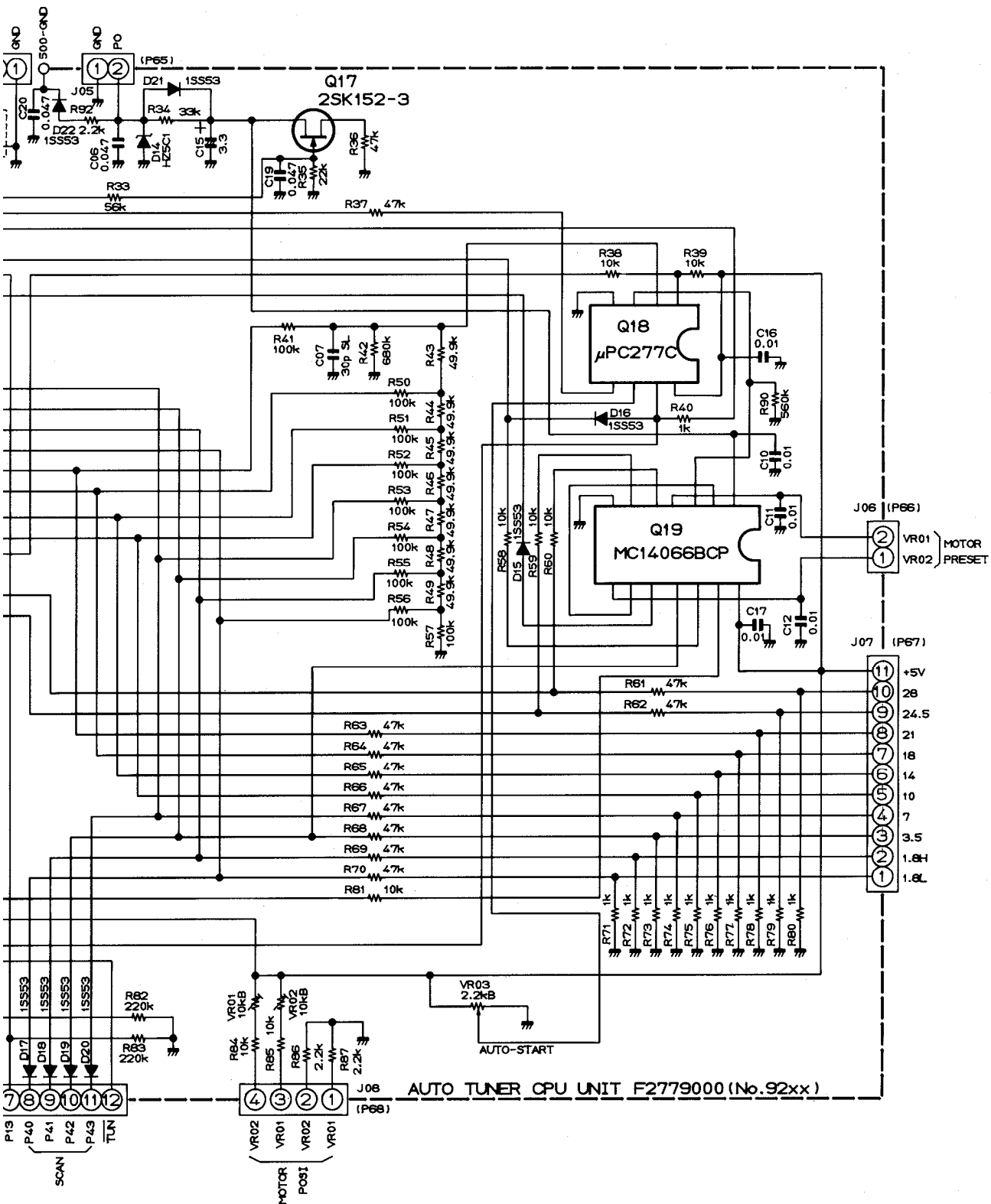

AUTO TUNER CPU UNIT F2779000 (No.92xx)

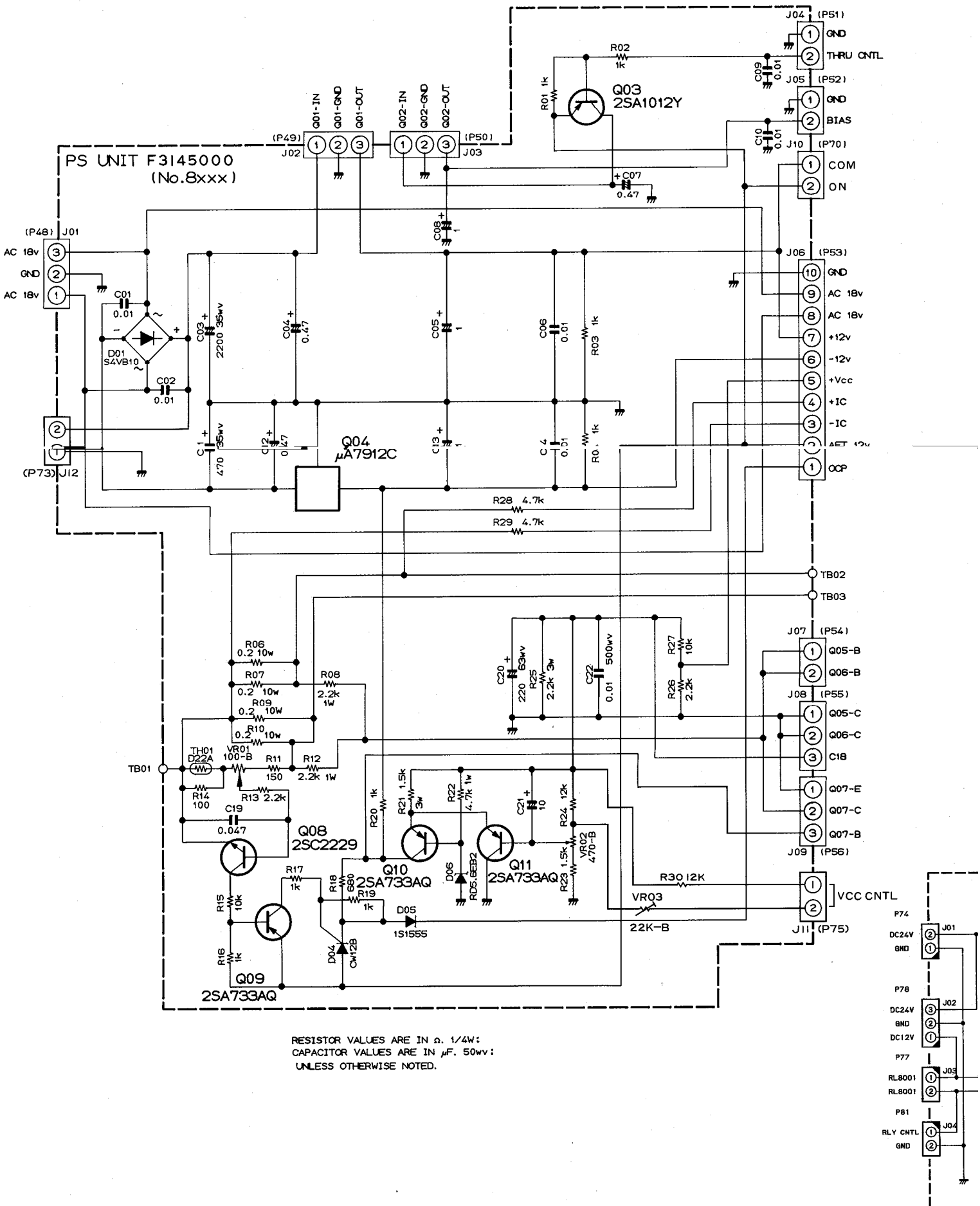

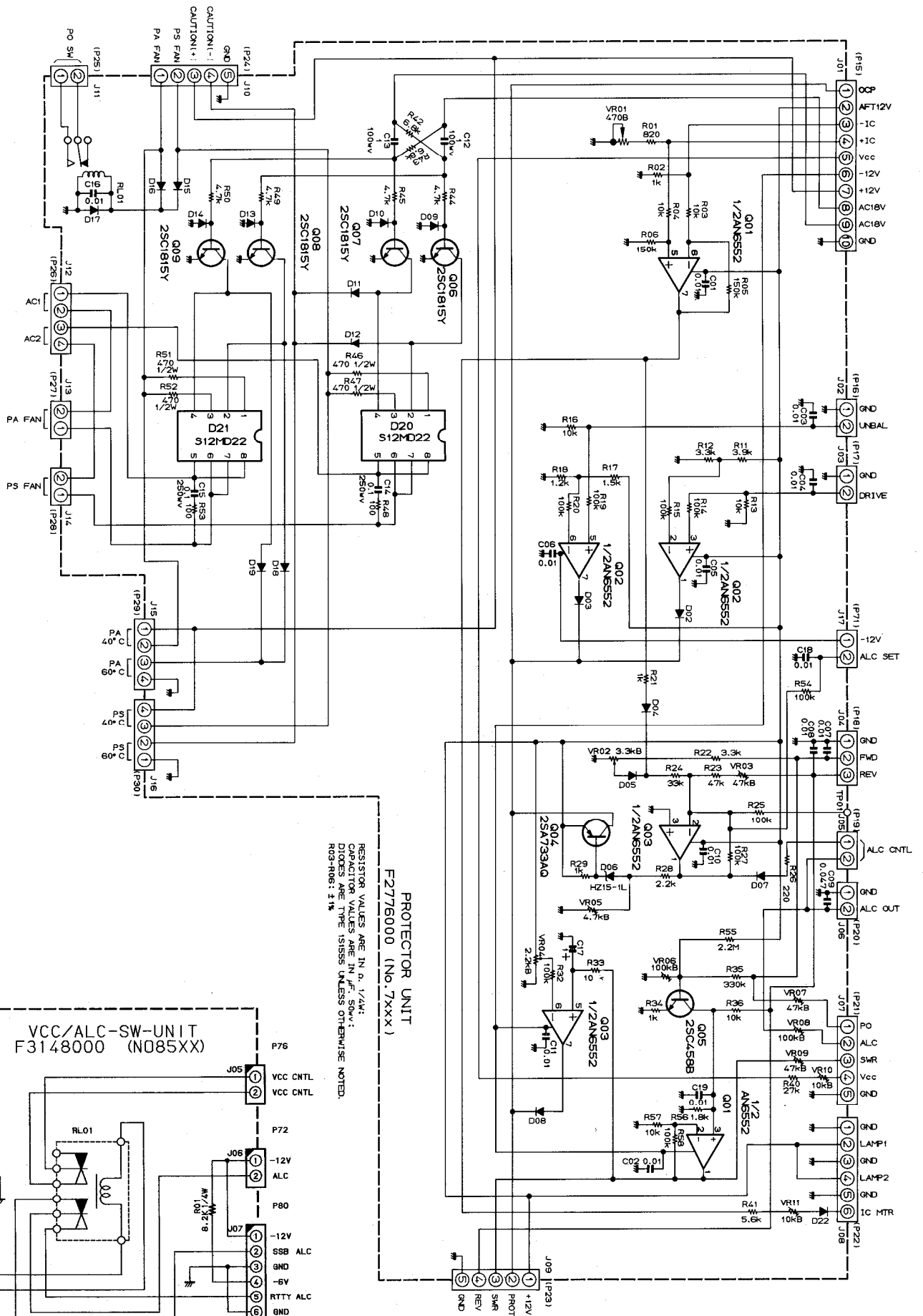

RESISTOR VALUES ARE IN Ω, 1/10W.
CAPACITOR VALUES ARE IN μF, 50V.
DIODES ARE TYPE 1N4001 UNLESS OTHERWISE NOTED.
R03-R06: 1%

PROTECTOR UNIT (No. 7xxx)

VCC/ALC-SW-UNIT (N085XX)

Alignment

depressed position, and the 7000 set to the un-depressed (up) position.

- Connect the PL-3-ohm dummy load (or three 50-ohm loads in parallel) to the antenna jack with the in-line switch.
- Apply maximum CW excitation from the transceiver, and adjust VR7006 on the Protector Unit for minimum reflection on the PL-3000 multimeter showing SWR.
- Adjust VR7009 on the Protector Unit for an SWR indication of exactly '3' on the multimeter.

SWR Protection Calibration

- With the equipment set up and connected as in the first two steps of the previous procedure, apply maximum excitation and adjust VR7014 on the Protector Unit very gradually until the PROTECT indicator blinks and the amplifier shuts down. Turn the potentiometer clockwise.

PT-6000 Calibration

- With the transceiver and PL-7000 set to CW mode, set the OPERATE and 25-7000

depressed position, and the 7000 set to the un-depressed (up) position.

- Connect one 50-ohm wattmeter to the antenna jack and adjust the exciter drive to maximum.
- Key the transmitter and adjust VR7003 on the PL-7000 multimeter.

ATU Sensitivity

- With the transceiver in CW mode, set the antenna to the depressed position, and the 7000 set to the un-depressed (up) position.
- With the 50-ohm dummy load connected to the antenna jack, adjust VR7005 until the ATU starts to work.

- Replace the 50-ohm dummy load with the PL-7000 (PT-6000) is installed. The VR7003, if necessary, should be adjusted so that the ATU starts to work.

