

FRG-7000

YAESU MUSEN CO., LTD.

TOKYO JAPAN.

TABLE OF CONTENTS

	(Page)
GENERAL DESCRIPTION	1
SPECIFICATIONS	2
CONTROLS AND SWITCHES	3
INSTALLATION	6
OPERATION	7
BLOCK DIAGRAM	10
CIRCUIT DESCRIPTION	10
ALIGNMENT AND MAINTENANCE	13
PARTS LIST	17
WORLD TIME CONVERSION CHART IN HOURS	24

"WARNING : TO PREVENT FIRE OR SHOCK HAZARD, DO
NOT EXPOSE THIS APPLIANCE TO RAIN OR MOISTURE."

COMMUNICATIONS RECEIVER FRG-7000



GENERAL DESCRIPTION

The model FRG-7000 is a high-performance, all solid state, communications receiver designed to cover the entire medium and high-frequency spectrum from 0.25 MHz - 29.9 MHz.

The FRG-7000 features a digital frequency display using large, bright digits for easy viewing. Also included is a 24-hour digital clock for both local and GMT time, with a timing feature for automatic receiver on/off switching.

The FRG-7000 is a triple-conversion superheterodyne receiver, utilizing a synthesized heterodyne oscillator known as the "Wadley Loop System," offering extremely stable receiver performance.

The FRG-7000 provides a 60 Hz. To reduce power consumption, the front panel lamps and digital display may be turned off.

The FRG-7000 provides a 60 Hz. To reduce power consumption, the front panel lamps and digital display may be turned off.

The FRG-7000 provides a 60 Hz. To reduce power consumption, the front panel lamps and digital display may be turned off.

able front-end attenuator assist in reception under a

The FRG-7000 is a precision-built instrument. Its performance, versatility, and reliability assure the discriminating listener of many hours of satisfying reception.

variety of conditions, and the continuously variable audio filter provides for minimizing the high or low frequency audio response, as needed. A front panel recording jack plus relay connection jacks on the rear panel provide the flexibility demanded by the discriminating listener.

Plug-in circuit boards are used in the FRG-7000, providing high reliability and ease of servicing. FET's and IC's are used throughout the receiver, providing maximum performance within a compact cabinet.

A built-in AC power supply allows operation from 100/110/117/200/220/234 volts AC 50/

The IF filtering in the bandwidth of 3 kHz (down), and 6 kHz for providing superb rejection.

The FRG-7000's switch and amplified AGC as

SPECIFICATIONS

Frequency Range:

0.25 MHz - 29.9 MHz

Speaker Impedance:

4 ohms

Type of Emissions:

AM, SSB (USB or LSB), CW

Audio Output:

2 watts

Sensitivity:

SSB/CW: Better than 0.7 μ V at S/N 10 dB

AM: Better than 2 μ V at S/N 10 dB

Power Requirement:

100/110/117/200/220/234 volts

AC 50/60 Hz

Selectivity:

SSB/CW \pm 1.5 kHz (-6 dB), \pm 4 kHz (-50 dB)

AM \pm 3 kHz (-6 dB), \pm 7 kHz (-50 dB)

Power Consumption:

AC 25 VA

Stability:

Less than \pm 500 Hz at any 30 minutes after warm-up

Size:

360 (W), 125 (H), 295 (D) mm

Weight:

Approx. 7 kg

Antenna Requirements:

Random wire 0.25 MHz - 1.6 MHz

50 Ohm unbalanced feed 1.6 MHz - 29.9 MHz

SEMICONDUCTOR COMPLEMENT

IC	SN76514N	2		μ PC14305	1
	TA7205AP	1		μ PC14308	2
	MC1416	2		NJM78L05A	1
	MC14011	1	FET	3SK40M	7
	MC14016	1		2SK19GR	8
	MC14027	1	Tr.	2SC372Y	8
	MC14081	1		2SC373	4
	MC14518B	1		2SC535A	1
	MC14519B	1		2SC784(O)	1
	MSM5502	1		2SC828	1
	MSM5592	1		MPS-A13	2
	SN7407N	2	Ge Diode	1S1007	11
	SN74LS00N	2	Si Diode	1S1555	17
	SN74LS90N	1		V06B	8
	SN74LS112N	1	LED	SL-103D	2
	SN74LS390N	1	LED Display	5082-7286	1
	SP8646B	1		5082-7740	5
	μ PA56C	1			
	μ PD546C-1(CPU)	1			

ACCESSORIES

The following accessories are packaged along with your FRG-7000:

(1) MINIATURE PHONE PLUG 2 ea.
For use in EXT SP or REC jacks.

(2) PHONE PLUG 1 ea.
For use with headphones.

(3) RCA TYPE PLUGS 2 ea.
For use in control of station equipment through relay jacks on rear panel.

(4) UHF COAX PLUG 1 ea.
For connection to HF antenna using coaxial feedline.

(5) EXTRA FUSES 2 ea.
3 amp fuse plus another 1 amp or 0.5 amp fuse, depending on local supply voltage.

(6) WIRES 3M/10M 1 ea.
For indoor antennas.

CONTROLS AND SWITCHES

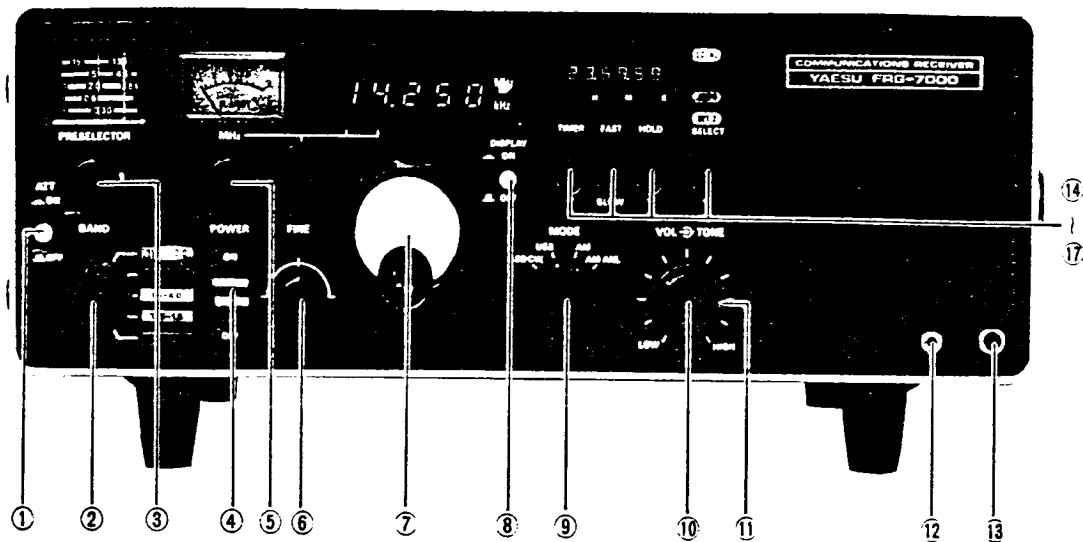

The FRG-7000 has been specifically designed for ease of operation. All controls have been adjusted

(3) PRESELECT

The preselector peaks the receiver circuits at the factory to ensure peak performance. The operator may be unfamiliar with the operation of some of the controls, and improper settings thereof may result in poor reception. For this reason, please become thoroughly familiar with the function of every control before attempting to operate the receiver.

maximum sensitivity received. The pres to match the color the preselector co frequency in use b marks on the colo for maximum sign speaker.

FRONT PANEL

(1) ATT (ON, OFF)

The ATT switch activates an attenuator for the receiver front end to minimize overloading under extreme conditions of strong adjacent signals. Maximum receiver sensitivity occurs with the ATT switch OFF.

(4) POWER

This is the main When it is in the will turn the receiv settings of SET 1 a

(2) BAND

The BAND switch has five positions for selecting the proper preselector range for peak receiver circuits.

(5) MHz

The MHz control tuned for reception correctly, e.g. bet

on/off switch for the receiver. OFF position, the timer circuit ver on or off, according to the and SET 2 on the digital clock.

selects the 1 MHz band to be n. When the control is not set between the 6 MHz and 7 MHz. Making the segments, the UNLOCK lamp will light to indicate that adjustment is needed.

(6) FINE

This control allows fine tuning of the received frequency.

(7) MAIN TUNING KNOB

This is the main tuning control for the receiver.

(8) DISPLAY (ON, OFF)

For conservation of energy, the front panel digital frequency display and lamps may be switched off with this button. The digital clock is not affected by this control.

(9) MODE (LSB/CW, USB, AM, AM/ANL)

This control selects the desired mode:

- LSB/CW: Lower sideband and CW
- USB: Upper sideband
- AM: Amplitude modulation
- AM/ANL: Amplitude modulation, automatic noise limiter

(10) VOL

This is the main volume control for the receiver.

(11) TONE

This control varies the audio filter so as to emphasize either high or low audio tones.

(12) REC

This jack is for recording purposes, and its output is set to approximately 50 mV, regardless of the setting of the volume control.

(13) PHONES

This is a standard 1/4" headphone jack. When the headphone plug is inserted into the jack, the internal speaker is cut off.

(14) TIMER

With proper setting of the SET 1 and SET 2 positions of the digital clock, placing the TIMER switch in the "down" position will allow automatic ON/OFF switching of the receiver by the digital clock.

(15) FAST/SLOW

This lever switch is used for setting the digital

(16) HOLD

This lever switch will lock the digital clock on the indicated time. This switch is useful for alignment of the GMT and LOCAL indications, and also for time setting if the FAST/SLOW control advances the time too far.

(17) SELECT

Each time the SELECT switch is pressed downward, the digital clock selection lamps are switched, corresponding to the change in the clock function. If the local time is being displayed (LOCAL lamp lighted), pressing the SELECT switch will cause the SET 1 lamp to light, and the clock will now display the time which has been programmed into the SET 1 position. Another press of the SELECT switch will cause SET 2 to be displayed, etc.

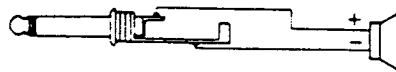

Speaker Connection
Via Headphone Plug



Phone Plug

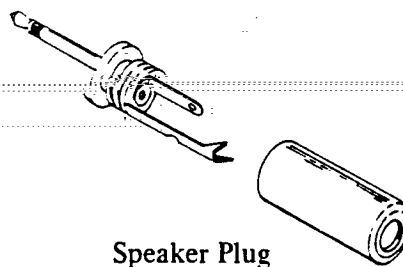

Speaker Plug

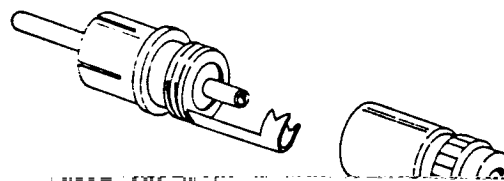
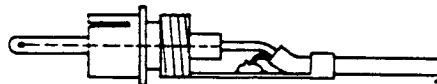

Phono Plug

rapid advance-
the slow speed

clock. The fast speed is used for
ment of the indicated time, and
is used for the final, fine adjustment.

REAR PANEL

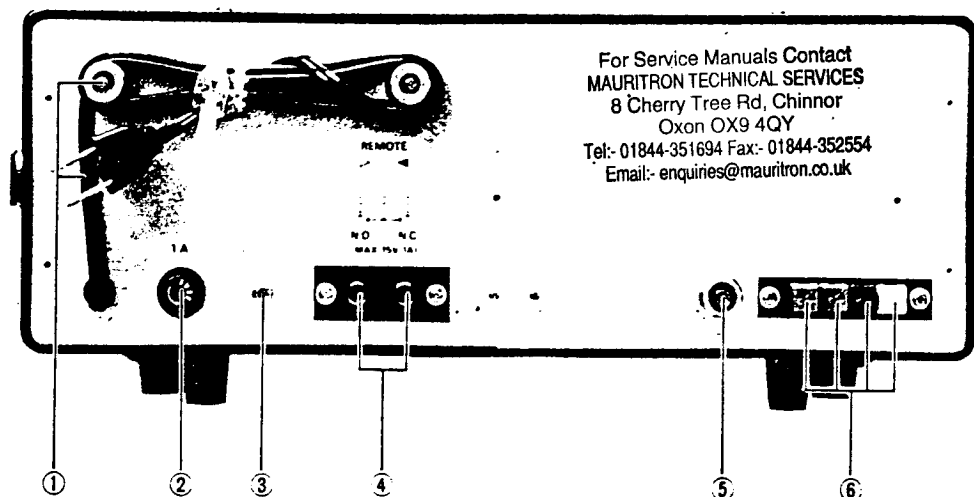

(1) POWER CORD AND CORD HOLDER

The power cord may be wrapped around the cord holder for packing purposes.

(2) FUSE

For 100/110/117 volt operation, a 1 amp fuse should be installed here. For 200/220/234 volt operation, a 1/2 amp fuse should be installed. **BE CERTAIN TO USE A FUSE OF THE PROPER RATING WHEN REPLACING FUSES.**

(3) EXT SP

This jack is for connection of an external speaker. The impedance is 4 ohms, and insertion of a plug into this jack disables the internal speaker.

(4) REMOTE (N.O./N.C.) (N.O. = Normally Open; N.C. = Normally Closed)

These two phono jacks are used for switching peripheral station equipment such as tape recorders, etc. When the TIMER switch is activated, and the clock passes the SET 1 time, the relay is activated. When the SET 2 time is passed, the relay returns to its normal state. With the TIMER switch off, the relay is in its normal state. The relay contacts are rated at 15 V at 1A.

(5) SW2

This is a standard UHF connector for coax-fed shortwave antennas.

(6) SW1, BC, E, MUTE

SW1 is a low-impedance connection for a random-length shortwave antenna.

BC is a high-impedance connection for a random-length shortwave antenna.

E is a ground connection.

MUTE is a connection for muting FRG-7000, as, for example, with an external standby switch. Shorting the MUTE terminal to ground will mute the receiver.

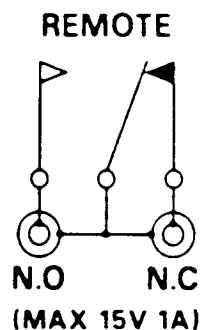

INSTALLATION

Carefully remove FRG-7000 from its carton, and inspect it for any signs of physical damage. Should any damage be observed, immediately notify the shipping company, stating the damage

TO THE RECEIVER. THE WARRANTY DOES NOT COVER DAMAGE CAUSED BY IMPROPER AC SUPPLY VOLTAGE.

Should it become necessary to adapt the FRG-7000 to a different AC supply voltage, refer to the chart below for the proper connections. After modification, make a notation on the rear panel regarding the AC supply voltage in use.

If fuse substitution is required, be certain to use a fuse of the proper rating. For 100 - 117 volt

CAUTION

PERMANENT DAMAGE WILL RESULT IF IMPROPER AC SUPPLY VOLTAGE IS APPLIED.
In detail, save the carton and the packing material for possible future use.

LOCATION

In general, the location of the FRG-7000 is not critical. However, it is recommended that excessively warm locations be avoided.

The FRG-7000 is supplied with a multi-voltage power transformer (export model only). Thus

OPERATION

FREQUENCY SELECTION

The operating frequency is read directly from the digital display. All digits of the operating

PRESELECTOR OPERATION

For peaking the receiver circuits for maximum sensitivity on the desired frequency the pre-

BROADCAST BAND (0.5 MHz - 1.6 MHz) OPERATION

Special caution should be observed when attempting broadcast band reception, as the MHz control may appear to select more than one range for the segment of the band below 1 MHz. Use only the

switch to USB or LSB as appropriate. Rotate the main tuning dial until a signal is heard. The FINE control is extremely useful when tuning in SSB signals. The VOLUME and TONE controls should be adjusted for the desired reception level.

Morse Code Signals:

Amateur and commercial Morse Code transmissions may be received by placing the MODE switch in the LSB/CW position, and tuning the main dial and FINE controls for the desired frequency.

AMATEUR BAND RECEPTION

SSB Voice Signals:

Virtually all amateurs use lower sideband (LSB) on the frequency bands below 7.3 MHz, and upper sideband (USB) above 14.0 MHz. Set the position of the MHz control immediately adjacent to the 1.0 MHz - 2.0 MHz band.

SHORTWAVE BROADCAST RECEPTION

International shortwave broadcast stations use the AM mode. Turn the POWER switch ON (TIMER switch OFF), place the MODE switch in the AM position, and select the desired frequency as described in the previous section. The VOLUME control should be adjusted for a comfortable listening level. The TONE control may be adjusted to provide the desired fidelity, and the FINE control will allow precise adjustment of the received frequency.

In the presence of extremely strong signals, the ATT switch may be placed in the ON position to prevent overload of the receiver front end. Should impulse noise be present, the MODE switch may be placed in the AM/ANL position.

REMOTE		
	N.O.	N.C.
2	OPEN	CLOSE
F	OPEN	CLOSE
	CLOSE	OPEN
F	OPEN	CLOSE
	CLOSE	OPEN
	OPEN	CLOSE

Power Switch	Timer Switch	RECEIVER		
		SET-1	SET-2	SET-3
OFF	OFF	OFF	OFF	OFF
ON	OFF	ON	ON	ON
OFF	ON	OFF	ON	-
			-	OFF
ON	ON	ON	OFF	-
			-	ON

Table 2

DIGITAL CLOCK OPERATION

The built-in digital clock will provide display of both your local time and Greenwich Mean Time (GMT). When the FRG-7000 is initially plugged in, the clock will indicate "00.00.00" and begin counting the seconds as they pass.

To set the clock to your local time, place the SELECT switch in the LOCAL position. Then use the FAST and SLOW switches to set the clock to the proper time. If desired, the clock may be set to some precise hour (for example, 11.00.00), and then the HOLD switch should be activated to hold the time at that point. When the time reaches exactly 11.00.00, release the HOLD switch, and the clock will resume counting. This technique is recommended for precise time calibration to a time standard such as WWV or JJY.

For setting to GMT time, it is recommended that the HOLD switch technique be used. Align the

LOCAL time to a suitable point (e.g. 16.00.00) and activate the HOLD switch. Place the SELECT switch in the GMT position, and use the FAST and SLOW switch to calibrate the GMT clock with the GMT appropriate for the LOCAL time being held (e.g. 16.00.00 Eastern Standard Time = 21.00.00 GMT). Release the HOLD switch to start both clocks simultaneously.

The HOLD switch will freeze the time on both clocks. The FAST and SLOW switch will advance only the clock being displayed. The clock is operative as long as the FRG-7000 is plugged in.

TIMER OPERATION

The SET 1 and SET 2 positions of the SELECT switch may be set to provide automatic ON and OFF control of the FRG-7000. For example, if a favorite program starts at 0730 local time, 07.30.00 may be stored in the SET 1 position for automatically turning the receiver on at that time. When it is desired to turn the receiver off automatically, that time may be stored in the SET 2 position. The TIMER circuitry may also be used for controlling peripheral equipment such as a tape recorder, as the timer relay actuates the REMOTE jacks on the rear apron.

The timer circuitry has the effect of switching the condition of the receiver as determined by the POWER switch. That is, when the POWER switch is OFF, and the TIMER switch ON, the receiver will be OFF until the SET 1 time. Between the SET 1 and SET 2 times, the receiver will be ON, and between the SET 2 and SET 1 times the receiver will again be OFF.

When the POWER switch is in the ON position, these relations are reversed. That is, with the POWER switch ON, and the TIMER switch ON, the receiver will be ON until the SET 1 time. From the SET 1 time until the SET 2 time, the receiver will be OFF, and after the SET 2 time the receiver will be ON until the SET 1 time.

The REMOTE contacts are controlled by the TIMER relay. In the period between the SET 1 and SET 2 times, the normally open (N.O.) jack will be CLOSED, and the normally closed (N.C.) jack will be OPEN. With the TIMER switch OFF,

regardless of the position of the POWER switch, the jacks are in their "normal" states.

For example, if you must be away from your station, but want to record a program, proceed as follows: preset the receiver to the proper frequency and peak the preselector, etc. Connect the FRG-7000 REC jack to the recording input of the tape recorder, and connect the tape recorder "footswitch" jack to the REMOTE N.O. jack. Align the SET 1 time to the start of the program and the SET 2 time to the end of the program. Place the POWER switch in the OFF position and the TIMER switch ON. Place the tape recorder in the record condition; it should not operate because the REMOTE N.O. jack is open. When the SET 1 time is reached, the FRG-7000 will turn on, the tape recorder will be activated, and both will operate until the SET 2 time (the end of the program).

CIRCUIT DESCRIPTION

The block diagram will provide you with a better understanding of this receiver. Basically, the FRG-7000 is a triple-conversion superheterodyne receiver utilizing a synthesized local oscillator for both the first and second mixers. The result is drift-free VFO operation.

The signal from the antenna is fed through the RF attenuator to the gate of the FET RF amplifier (Q101 (3SK51-03)). The amplified signal is fed through a low-pass filter (cutoff frequency 35 MHz) to the first balanced mixer, consisting of Q102 and Q103 (both 2SK19GR), where the incoming signal is mixed with a signal from the

The 52.5 MHz output signal from Q201 is fed to the second pre-mixer Q202 (3SK51-03), where the 52.5 MHz signal is mixed with a 63.2 MHz signal generated by Q207 (2SK19GR), producing a 10.7 MHz IF signal.

The 10.7 MHz IF signal passes through a 10.7 MHz ceramic filter and is amplified by Q203 (2SK19GR) and fed to mixer Q204 (SN76514), where the 10.7 MHz signal is mixed with a 63.2 MHz signal generated by Q207, producing a filtered 52.5 MHz signal.

The 52.5 MHz signal is then amplified by Q205 (2SK19GR) and fed to the heterodyne oscillator, Q301 (2SC7840), which provides a signal varying between 55.5 and 84.5 MHz.

A 52.5 MHz heterodyne signal is produced as follows: The synthesized oscillator Q301 (2SC7840) provides a 52.5 MHz signal, which is filtered to the harmonic generator D501 - D502 (both 1S1007). This produces a series of harmonics from 3 to 32 MHz. This signal is fed to the first pre-mixer, Q201 (SN76514), where the 55.5 MHz - 84.5 MHz and 3 MHz - 32 MHz signals are mixed, producing a 52.5 MHz signal.

The 54.5 MHz - 55.5 MHz signal is mixed with the 52.5 MHz heterodyne signal by Q105 (2SK19GR), resulting in a 2 MHz - 3 MHz IF

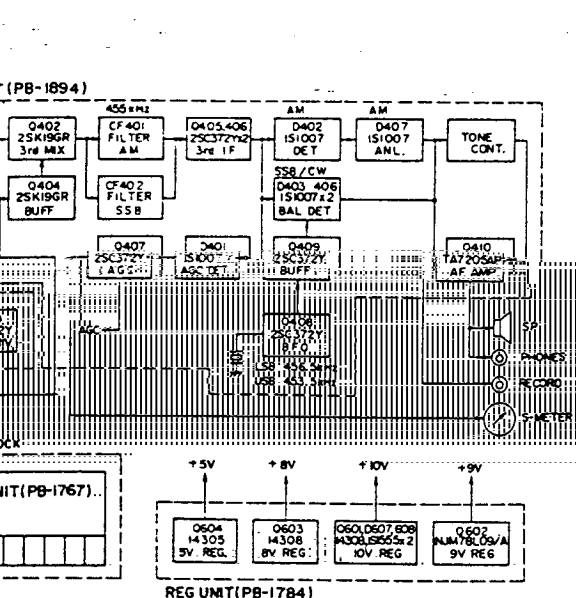

FRG-7000
BLOCK DIAGRAM

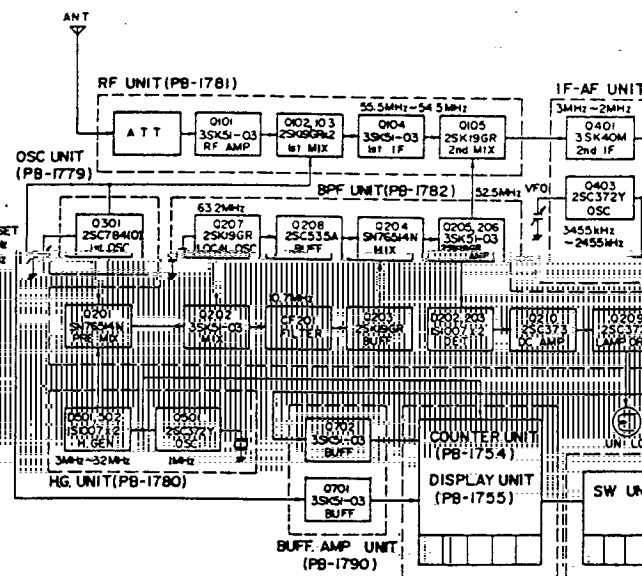

BLOCK DIAGRAM

signal. This IF signal is amplified by Q₄₀₁ (3SK40M) and fed to a third mixer Q₄₀₂ (2SK19GR), where the IF signal is mixed with

(2SC372Y). The MODE switch shifts the BFO frequency for reception of an LSB or USB signal.

2455 kHz. 2455 kHz heterodyne signal produced by a 455 kHz third IF signal. The 2455 kHz - 55 kHz heterodyne signal is generated by VFO oscillator Q₄₀₃ (2SC372Y) and fed through buffer amplifier Q₄₀₄ (2SK19GR) to Q₄₀₂. The 55 kHz IF signal is fed through a ceramic filter Q₄₀₁ for AM, or CF-402 for SSB and CW, to eliminate adjacent-frequency interference.

The output from the detector is amplified by Q₄₀₆ (2A7205AP) for delivery to the speaker.

A portion of the output from the last IF amplifier Q₄₀₆ is fed to the AGC (Automatic Gain Control) rectifier D₄₀₁ (1S1007). The rectified AGC voltage is then amplified by AGC amplifier Q₄₀₇ (2SC372Y) and fed to Q₁₀₁, Q₄₀₁, and Q₄₀₅ to control the gain of these stages automatically according to the strength of the received signal. Thus, the receiver output is not affected by variations in signal strength which may be caused by phase shift on the incoming signal. The S-meter is placed in the emitter circuit of Q₄₀₇, in which the emitter current changes in accordance with the incoming signal strength.

The signal is then amplified by the third IF amplifier Q₄₀₅ and Q₄₀₆ (both 2SC372Y), and fed to the appropriate detector. The AM signal is detected by diode detector D₄₀₂ (1S1007).

Balanced demodulator D₄₀₃ - D₄₀₆ (all 1S1007) is used for the detection of SSB and CW signals. The carrier signal for SSB and the beat frequency signal for CW (generated by BFO oscillator Q₄₀₃ (2SC372Y)) are fed to the balanced demodulator through buffer amplifier Q₄₀₉

The 55.5 MHz - 84.5 MHz and 2455 kHz - 3455 kHz signals are amplified, respectively, by buffer amplifiers Q₇₀₁ and Q₇₀₂ (both 3SK51-03), and fed to the counter display the received frequency.

FREQUENCY f	1ST OSC fo ₁	1ST IF (fo ₁ - fi ₁) fi ₁	REF FREQ (1MHz × n) fh	2ND OSC (fo ₁ - fh) fo ₂	2ND IF (fi ₁ - fo ₂) fi ₂	3RD OSC fo ₃	3RD IF (fo ₃ - fi ₂) fi ₃
500kHz	55.5MHz	55.0MHz	3MHz	52.5MHz	2.500kHz	2.955kHz	455kHz
1,500	56.5	55.0	4	"	2,500	2,955	"
2,500	57.5	55.0	5	"	2,500	2,955	"
58.5	55.0	6	"	2,500	2,955	"	"
59.5	55.0	7	"	2,500	2,955	"	"
60.5	55.0	8	"	2,500	2,955	"	"
61.5	55.0	9	"	2,500	2,955	"	"
62.5	55.0	10	"	2,500	2,955	"	"
63.5	55.0	11	"	2,500	2,955	"	"
64.5	55.0	12	"	2,500	2,955	"	"
65.5	55.5	13	"	3,000	3,455	"	"
66.5	55.5	14	"	3,000	3,455	"	"
67.5	55.5	15	"	3,000	3,455	"	"
68.5	55.5	16	"	3,000	3,455	"	"
69.5	55.5	17	"	3,000	3,455	"	"
70.5	55.5	18	"	3,000	3,455	"	"
71.5	55.5	19	"	3,000	3,455	"	"
72.5	55.5	20	"	3,000	3,455	"	"
73.5	55.5	21	"	3,000	3,455	"	"
74.5	55.5	22	"	3,000	3,455	"	"
75.5	55.5	23	"	3,000	3,455	"	"
76.5	55.4	24	"	2,900	3,355	"	"
77.5	55.3	25	"	2,800	3,255	"	"
78.5	55.2	26	"	2,700	3,155	"	"
79.5	55.1	27	"	2,600	3,055	"	"
80.5	55.0	28	"	2,500	2,955	"	"
81.5	54.9	29	"	2,400	2,855	"	"
82.5	54.8	30	"	2,300	2,755	"	"
83.5	54.7	31	"	2,200	2,655	"	"
84.5	54.6	32	"	2,100	2,555	"	"

Table 3 Frequency Relationship

The counter unit utilizes a 4-bit microcomputer unit (CPU) to display the frequency being received. The CPU also drives the digital clock, which displays both local and GMT time. The clock section of the CPU controls the timer function for ON/OFF control of the receiver and peripheral station equipment.

The regulated power supply consists of four regulators: Q₆₀₁ (14308), Q₆₀₂ (NJM 78L09A), Q₆₀₃ (14308), and Q₆₀₄ (14305), to deliver stabilized voltages of 10V, 9V, 8V, and 5V to various circuits in the receiver.

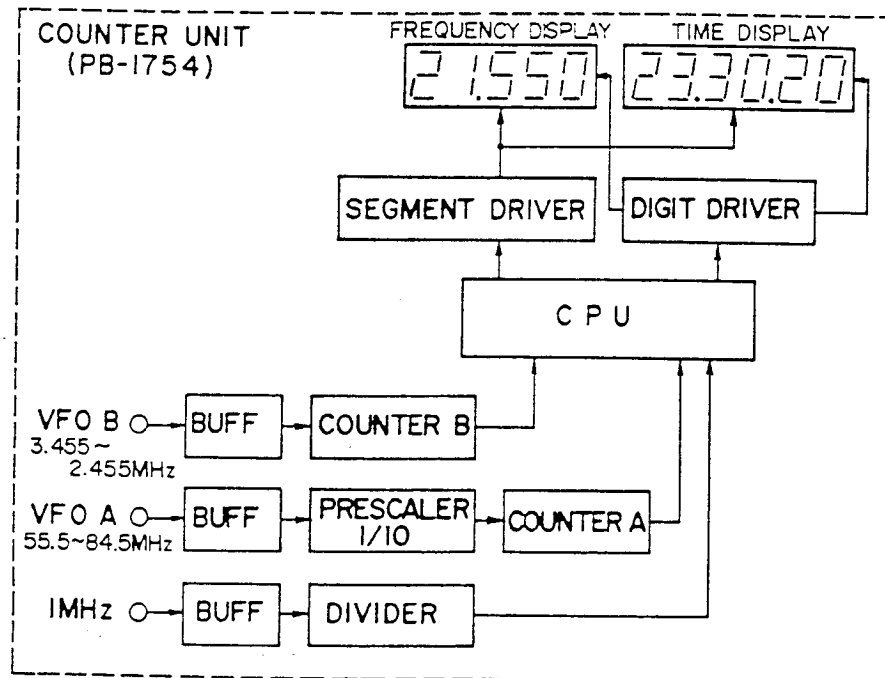

MAINTENANCE & ALIGNMENT

GENERAL

The FRG-7000 has been carefully aligned and tested at the factory prior to shipment, and, with normal usage, it should not require other than the usual attention given to electronic equipment. Service or replacement of a major component may entail substantial realignment; under no circumstances, however, should realignment be attempted unless the operation of the receiver is fully understood and the malfunction has been definitely attributed to misalignment rather than component failure. Service work should be performed by experienced personnel using proper test equipment.

(1) Local Oscillator T_{207}

Connect a VTVM between TP_{202} and TP_{204} (ground). Adjust T_{207} for 0.6V RMS as indicated on the VTVM. Connect a frequency counter to TP_{202} , and make sure that the output frequency is 63.2 MHz.

(2) Output level $T_{201} - T_{206}$

Connect a VTVM between TP_{108} and TP_{109} (ground). Set the FRG-7000 MHz control to 29 MHz. Carefully adjust the MHz control for a maximum VTVM reading. Then peak $T_{201} - T_{206}$ for a maximum VTVM reading.

(3) Harmonic generator TC_{501}

Connect a frequency counter between TP_{502} and TP_{501} (ground), and adjust TC_{501} for a reading of 1 MHz. The output voltage at TP_{502} should be approximately 0.2V RMS.

(4) Oscillator Unit T_{301}, TC_{301}

Connect a frequency counter between TP_{107} and TP_{104} (ground). Set the FRG-7000 MHz control to the fully counterclockwise position. Adjust T_{301} for a reading of 54.0 MHz on the counter. Set the MHz control to the fully clockwise position, and adjust TC_{301} for a reading of 85.2 MHz on the counter. Repeat the above adjustments, if necessary, until the UNLOCK lamp turns off at every 1 MHz incremental advancement of the MHz control.

(5) VFO Frequency T_{403}, TC_{403}

This alignment should be performed after the receiver has been allowed to warm up 30 minutes. Connect a frequency counter between TP_{402} and TP_{404} (ground). Set the main tuning knob to the fully clockwise position, and adjust T_{403} for a reading of 2380 kHz on the counter. Set the main tuning knob next to the fully counterclockwise position, and adjust TC_{403} for a counter reading of 3480 kHz. Repeat this adjustment, if necessary, until complete tracking is accomplished. The output voltage at TP_{402} should be 0.3V - 0.6V RMS.

(6) Second IF Alignment $T_{401}, T_{402}, TC_{401}, TC_{402}$

Connect a signal generator between TP_{105} and TP_{106} (ground). Set the MODE switch to the AM position, and set the signal generator output frequency to 2.1 MHz (the FRG-7000 display should indicate 900 kHz). Peak T_{401} and T_{402} for a maximum S-meter reading.

Set the signal generator to 2.9 MHz (the FRG-7000 digital display should indicate 100 kHz). Peak TC_{401} and TC_{402} for a maximum S-meter reading. Repeat the above adjustments until complete tracking is accomplished.

(7) Third IF Alignment T_{404}, T_{405}

Connect a signal generator to TP_{401} and TP_{406} (ground), and set its output to 2.9 MHz (the FRG-7000 digital display should indicate 100 kHz). Peak T_{404} and T_{406} and T_{405} for a maximum S-meter reading.

(8) S-meter Sensitivity VR_{401}

Connect a signal generator to SW2 and apply an 11 MHz 100 dB signal. Tune the receiver to 11 MHz and adjust VR_{401} for a full scale reading on the S-meter.

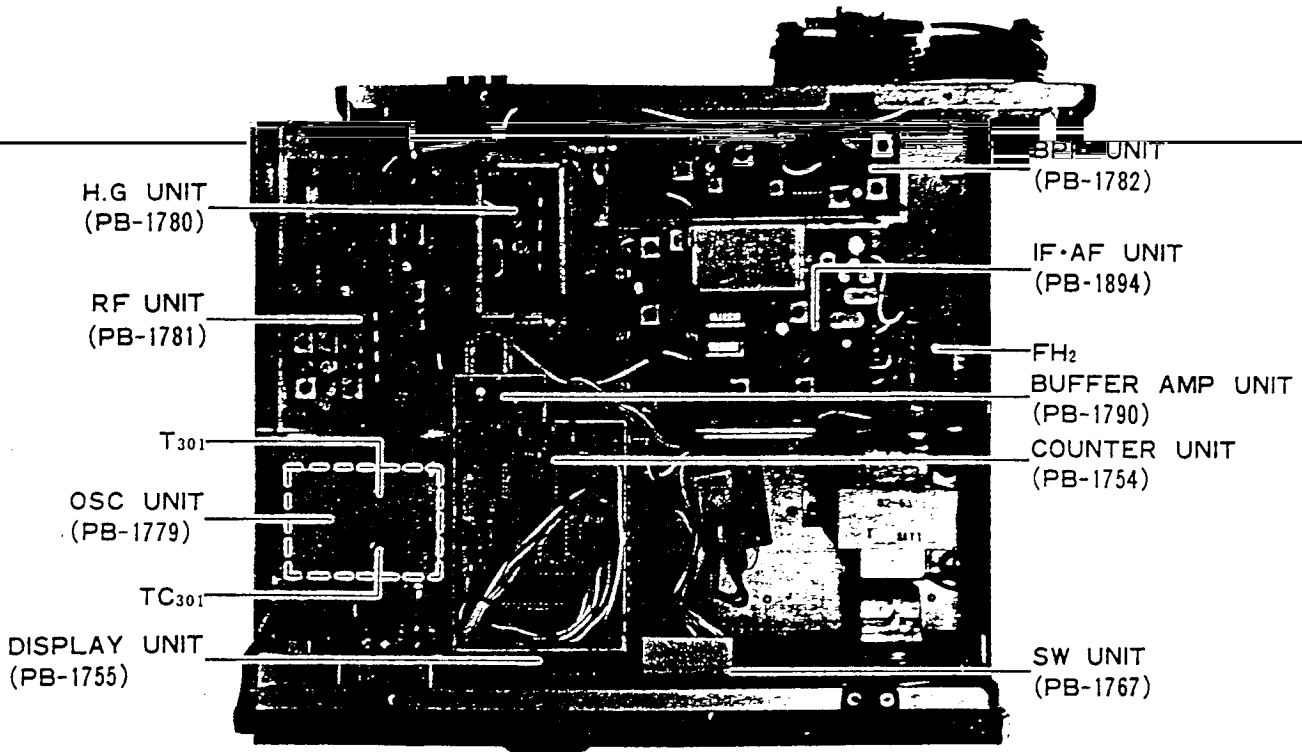

TOP VIEW

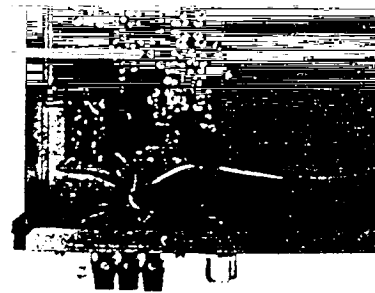
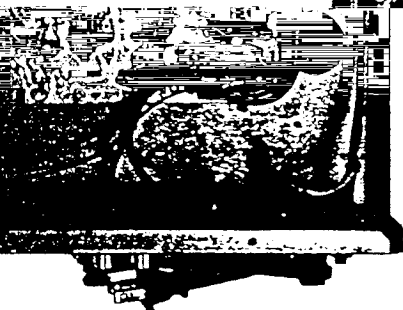
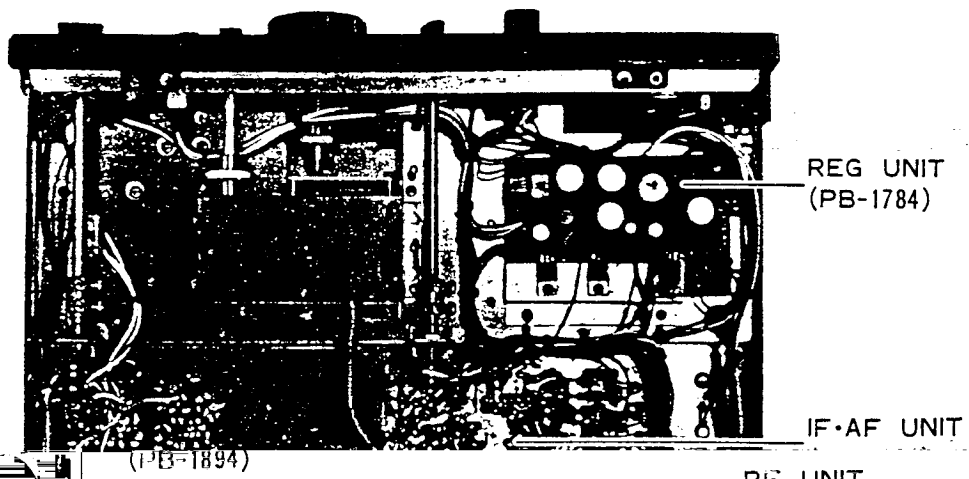

BOTTOM VIEW

BOTTOM VIEW

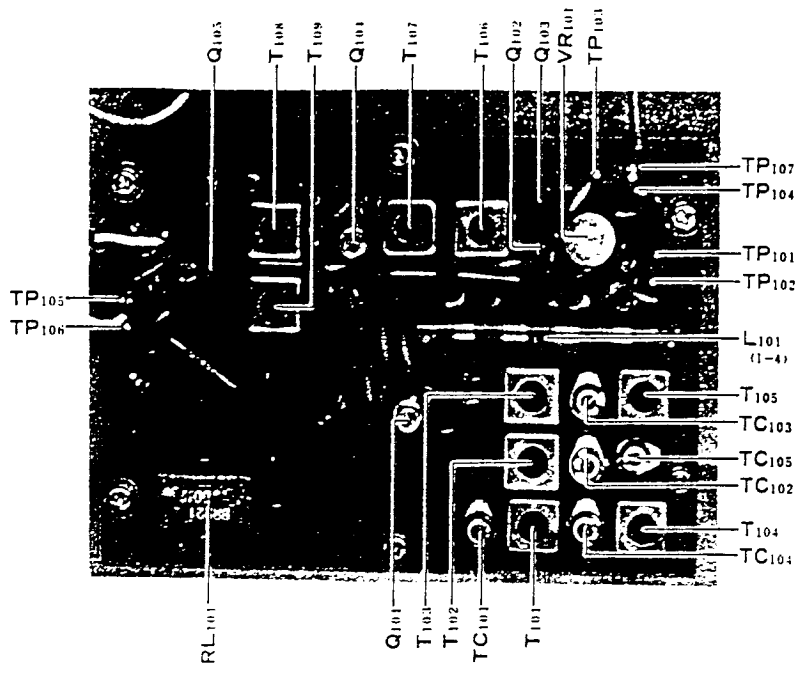

RF UNIT (PB-1781)

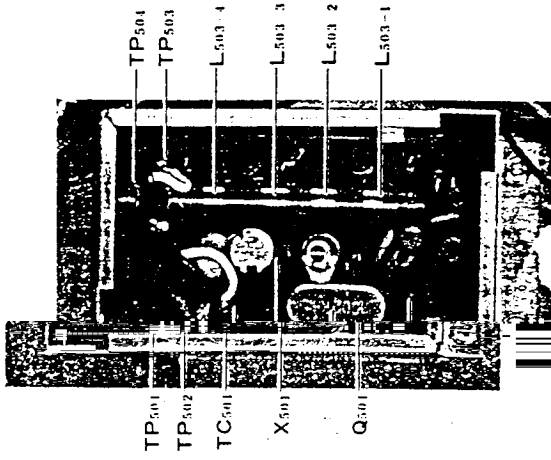

H.G. UNIT (PB-1780)

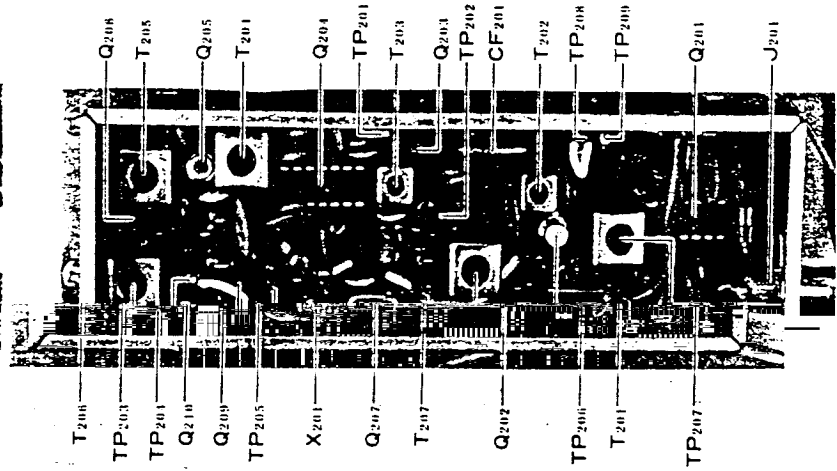

BPF UNIT (PB-1782)

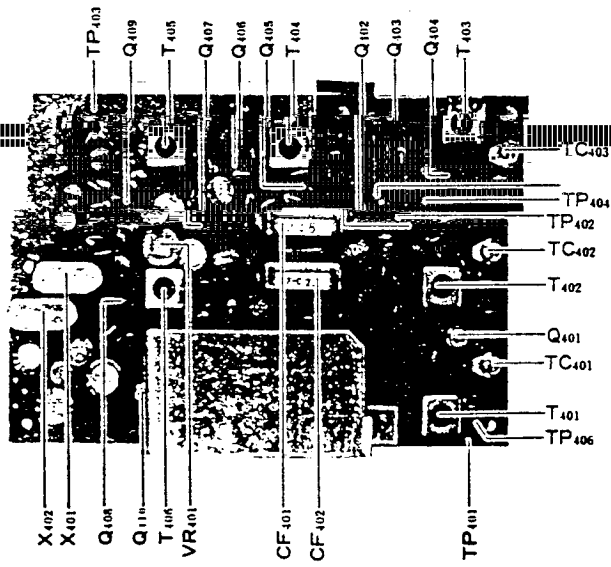

IF-AF UNIT (PB-1894)

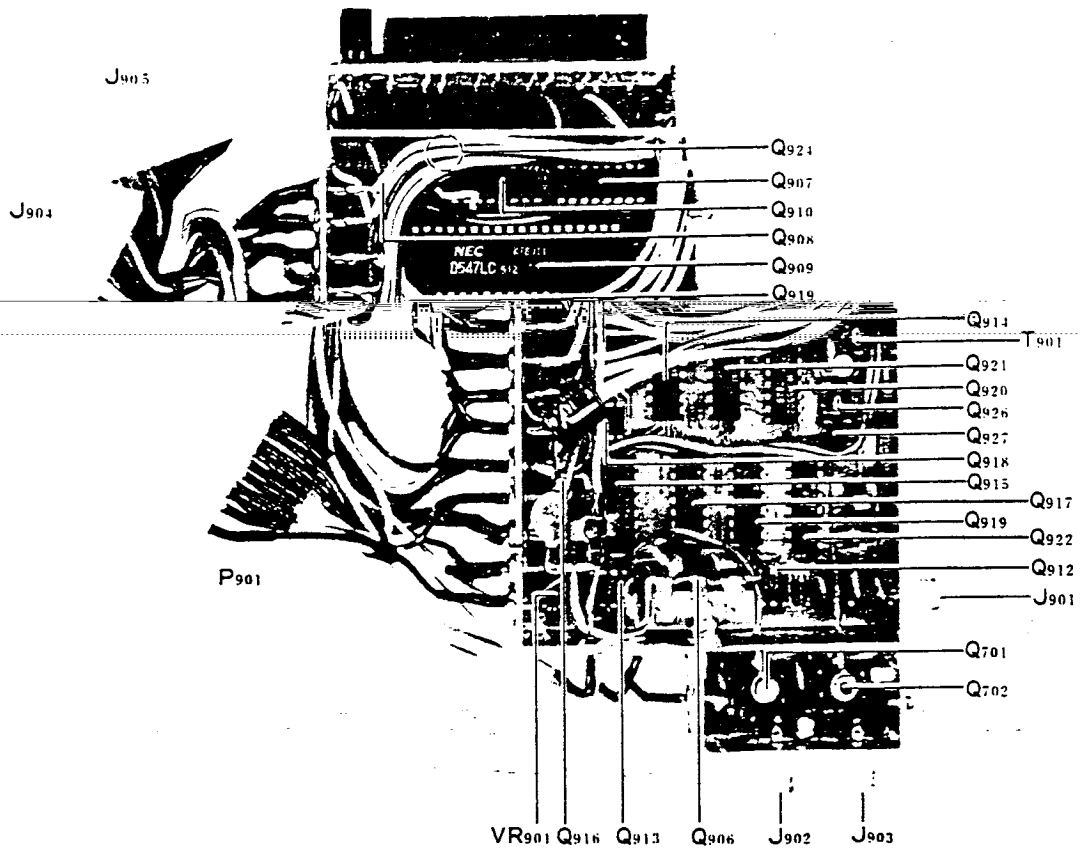

COUNTER UNIT(PB-1754)

PARTS LIST

MAIN CHASSIS						
Symbol No.	Part No.	Description				
		RESISTOR				
R5	40143470	Carbon film 1/4W VJ 47Ω				FUSE
R3, 6	41143680	" " " TJ 68Ω	F1	73000013	1A (100V~117V)	
R1	41143222	" " " " 2.2kΩ		73000012	0.5A (200V~234V)	
R2	40143223	" " " VJ 22kΩ	F2	73000003	3A	
R4	42124120	" composition 1/2W GK 12Ω				
R7, 8, 9	42124225	" " " " 2.2MΩ				
R10	44204339	Wire wound 2W 3.3Ω				
						FUSE HOLDER
			FH1	69030005	SN-1301	
			FH2	69030003	F3294	
		POTENTIOMETER				
VR1	49800104	DM10A 10kΩB/10kΩB				
						PILOT LAMP
			PL1, 2, 13, 14	14000033	BQ-034-22529A	
		CAPACITOR	PL3, 9~12	14000031	BQ-034-22527A	
C2	31820050	Ceramic disc 50WV 5PF CH	PL4~8	14000032	BQ-034-22528A	
C3	30820103	" " " 0.01μF				
C1	56825104	Mylan " 0.1μF				
C4	34220108	Electrolytic 25WV TT 1000μF				
						RF UNIT
			Symbol No.	Parts No.	Description	
				017811AZ	RF board with components	
		VARIABLE CAPACITOR	PB-1781A	60417811	P.C. Board	
VC1, 2	39000078	CY-31A 335PF x 2				
VC3	39000079	TSN 150Sx04-1 4PF				
						FET
			Q102, 103, 105	22800195	2SK19GR	
			Q104	22800195	3SK40M	
PT1	52000062	52-62	Q101	22800513	3SK51-03	
						DIODE
			D101	21015550	Silicon 1S1555	
		METER				
M1	74000380	KTC-024				
						RESISTOR
			R121	40143100	Carbon film 1/4W VJ 10Ω	
		SPEAKER	R119	40143330	" " " " 33Ω	
SP1	76000022	SM-92Y 4Ω 4W	R120	40143470	" " " " 47Ω	
			R107, 122	40143101	" " " " 100Ω	
			R102, 108, 113, 116, 124	40143221	" " " " 220Ω	
		SWITCH	R103	41143221	" " " TJ 220Ω	
S1	62000002	ESR-E365R20A	R104, 105	40143561	" " " VJ 560Ω	
S2	62000020	ESR-E264R20	R112	40143681	" " " " 680Ω	
S3	65000012	PW-22	R115	40143152	" " " " 1.5kΩ	
S4	65000038	PW-42	R110,	40143103	" " " " 10kΩ	
S5	64000053	8H2011	R111	40143273	" " " " 27kΩ	
			R118	40143393	" " " " 39kΩ	
			R117	40143473	" " " " 47kΩ	
			R101, 106, 109, 114, 123	40143104	" " " " 100kΩ	
		RECEPTACLE				
J1	68000011	M-BR-06D				
J2	68040006	SQ2450-03				
J3, 5	68020012	SG8050-07				
J4	68030002	SG7814				
J6	80043741	UP-021				

C213, 233, 236, 238	31820101	Ceramic disc 50WV 100PF CH					
CAPACITOR							
C209, 210, 216, 220, 223, 235, 239	30820102	" " " 0.001μF	C301	31827070	Ceramic disc 50WV 7PF UJ		
			C304	31827220	" " " 22PF "		
			C305	31827330	" " " 33PF "		
C206, 214, 217~219, 221, 222, 224, 227, 229~232, 234, 237, 241	30820103	" " " 0.01μF	C302, 303	30820103	" " " 0.01μF		
			C307, 308	30820473	" " " 0.047μF		
C205, 207, 208, 211, 215, 225, 228	30820473	" " " 0.047μF					
VARIABLE CAPACITOR							
			VC301	39000074	C343C 15PFx4		
TRIMMER CAPACITOR							
		TRANSFORMER	TC301	39000001	ECV-1ZW 10x32 10PF		
T201, 204~206	55003294	#220361					
T207	55003295	#220362					
T202, 203	55003296	#220187					
TRANSFORMER							
			T301	55003208	#220052		
INDUCTOR							
L201	55003206	#220053	L301	53010003	Micro inductor 250μH		
L202	55003207	#220054					
L204, 206	53020013	Micro inductor 150μH					

Symbol No.	Parts No.	Description
#203, #205	5302000	" " 1mH
		IF, AF unit with components
	PB-1894	60418940 P.C. Board
		US PIN JACK
J101	68020008	SQ3056 IC, FET & TRANSISTOR
		Q410 25000162 IC TA7205AP

Symbol No.	Parts No.	Description
23800401	38K40M	Diode
22303724	2SQ372Y	Transistor
21030070	1S1007	Germanium
23018550	1S1855	Silicon
22303724	2SQ372Y	Transistor
		CRYSTAL
71600035	456.5KHz	HC-6/W
71600034	453.5KHz	
		CERAMIC FILTER
71200012	LF-C6	
71200021	GF-C2A	
		RESISTOR
40143150	Carbon film 1/4W VJ 15Ω	
40143470	" " " " 47Ω	
454 40143101	" " " " 100Ω	

Symbol No.	Parts No.	Description
	9-100008	9-100008 Wrapping terminal
		OSC Unit
		OSC board with components
	PB-179A	60417910 P.C. Board
		TRANSISTOR
Q301	22307843	2SG784 O
		RESISTOR
R304	40143101	Carbon film 1/4W VJ 100Ω
R303	40143821	" " " " 820Ω
R302	40143472	" " " " 4.7kΩ
R301	40143223	" " " " 22kΩ

R420, 421	41143101	Carbon film 1/4W TJ	100Ω	C438, 444	32824510	Dipped mica 50WV	51PF
	40143121	" " " "	120Ω	C458	32824820	" " "	82PF
R408, 410, 414, 424, 426, 433, 435, 437, 453	40143221	" " " "	220Ω	C460	32824121	" " "	120PF
				C435	32824271	" " "	270PF
				C441	32824391	" " "	390PF
R401	40143331	" " " "	330Ω	C432	32824471	" " "	470PF
R430	40143471	" " " "	470Ω	C462	32824681	" " "	680PF
R449	40143561	" " " "	560Ω	C431, 463	32824102	" " "	1000PF
R431	40143681	" " " "	680Ω		36825332	Mylar	" 0.0033μF
R425, 440, 458	40143102	" " " "	1kΩ	C427	36825472	"	" 0.0047μF
R416	40143152	" " " "	1.5kΩ	C426	36825103	"	" 0.01μF
R415, 418, 419, 422, 455, 457	40143222	" " " "	2.2kΩ	C437	36825223	"	" 0.022μF
				C436	36825333	"	" 0.033μF
R413, 417, 428, 451	40143332	" " " "	3.3kΩ	C416, 420, 422, 442, 468	36825473	"	" 0.047μF
R448	40143392	" " " "	3.9kΩ	C445	36825104	"	" 0.1μF
R452	40143472	" " " "	4.7kΩ	C428	36825224	"	" 0.22μF
R411	40143822	" " " "	8.2kΩ		34220105	Electrolytic 16WV	1μF
R427	40143103	" " " "	10kΩ	C425, 447	34220225	"	" 2.2μF
				C439	34220226	"	" 22μF
R450, 460	40143183	" " " "	18kΩ		34220336	"	" 33μF
				C442, 446, 448	34220476	"	" 47μF
R459	40143333	" " " "	33kΩ	C440, 467, 469	34220107	"	" 100μF
R406	40143393	" " " "	39kΩ				
R404	40143473	" " " "	47kΩ				
R402	40143563	" " " "	56kΩ				
R436	40143683	" " " "	68kΩ				
R412, 434, 441, 456	40143104	" " " "	100kΩ				TRIMMER CAPACITOR
				TC403	39000002	ECV-1ZW 20x32	20PF
R405	40143154	" " " "	150kΩ	TC401, 402	39000005	ECV-1ZW 50x32	50PF
R423, 438	40143224	" " " "	220kΩ				

TRANSFORMER

			T401	55003209	R12-5783	#220060
			T402	55003210	R12-5780	#220061
			T403	55003211	R12-5775	#220062
H401	29090005		T404, 405	54140970	R12-4097	#220101
			T406	54140990	R12-4099	#220156

THERMISTOR

D-22A

INDUCTOR

			L401, 402	53020022	Micro inductor FL4H 4.7μH
R401	49905471	SR19R	L414	53020024	FL5H 27μH

POTENTIOMETER

470ΩB

CAPACITOR

			L415	53020023	FL5H 100μH
			L403	53020001	FL5H 1mH
			L404, 406, 407, 410~412	53020003	FL7H 3.9mH
C415, 419	31820010	Ceramic disc 50WV	L405, 408, 409, 413, 416	53030003	" (shielded) S6-392 3.9 mH
C434	31820070	" " "			
C430	31820100	" " "			
C461	31820220	" " "			
C465	31820270	" " "			
C459	31827820	" " "	P401	67020007	US PIN PLUG SQ4052
C421, 423	31829101	" " "			
C453	31829151	" " "		91100008	Wrapping terminal C
C454	31829221	" " "			
C424	30820102	" " "		80022070	Heat sink
C401, 402, 406, 407, 409~414, 418, 429, 449, 450, 464, 466	30820103	" " "			
C403, 404, 405, 408, 417, 433, 451, 452, 455, 457, 470	30820473	" " "			
			HG UNIT		
			Symbol No.	Parts No.	Description
				017801AZ	HG unit with components
			PB-1780A	60417801	P.C. Board
C456	32824200	Dipped mica			" 20PF

TRANSISTOR			REG UNIT		
Symbol No.	Part No.	Description	Symbol No.	Part No.	Description
Q501	22303724	2SC372Y		017841AZ	Regulator unit with components
			PB-1784A	60417841	P.C. Board
DIODE					
D501, 502	21010070	Germanium 1S1007			IC
			Q604	25000105	μPC 14305
			Q601, 603	25000116	μPC 14308
CRYSTAL			Q602	25000170	NJM 78L09A
X501	71600026	HC-6/W 1MHz			
RESISTOR			D607, 608	21015550	Silicon 1S1555
R505, 506	40143101	Carbon film 1/4W VJ 100Ω	D601~606	21090022	" V06B
R503	40143221	" " " " 220Ω			
R502	40143103	" " " " 10kΩ			
R501	40143104	" " " " 100kΩ			
RESISTOR			R602	42124220	Carbon composition 1/2W GK 22Ω
CAPACITOR					
C502, 510	31820080	Ceramic disc 50WV 8PF CH			
C511	31820150	" " " 15PF "			CAPACITOR
C509, 514	31820270	" " " 27PF "	C610, 611	30820473	Ceramic disc 50WV 0.047μF
C508	31820330	" " " 33PF "	C605	34220336	Electrolytic 16WV 33μF
C506	31820680	" " " 68PF "	C604, 607, 608	34220107	" " 100μF
C501, 504, 505, 507	30820103	" " " 0.01μF	C606, 609	34220108	" " 1000μF
C503	33824820	Dipped mica " 82PF	C601~603	34320108	" 25WV 1000μF
C512	34220476	Electrolytic 16WV TW 47μF			
RELAY			RL601	70000036	AW 62209 HB2-DC 6V
TRIMMER CAPACITOR					
TC501	39000004	ECV-1ZW 40x32 40PF			
MINI CONNECTOR					
			J601	168110008	5047-11 #240063A

100008	Wrapping terminal C
BUFFER AMP UNIT	
Part No.	Description
7901AZ	Buffer board with components
417901	P.C. Board
FET	
800401	3SK40M

INDUCTOR		(with wire)
L5G3	550000.2	#220051
L5C2	53020022	Micro inductor FL4E 4.7mH
L501	53020001	" " FL5H 1mH
L504	53020003	" " FL7H 3.9mH
US PIN PLUG		
P501, 502	67020007	SQ4052
	91100008	Wrapping terminal C
		Symbol No. PB-1790A
		Q701, 702

		RESISTOR				SWITCH	
R703, 709	40143221	Carbon film	1/4W VJ 220Ω	S801	64000107	SLE 72251	
R704	40143152	" " " "	1.5kΩ	S802	64000103	SLE 62251	
R710	40143272	" " " "	2.7kΩ	S803	64000106	SLE 82301	
R702, 707	40143333	" " " "	33kΩ	S804	64000108	SLE 64251	
R705, 708	40143473	" " " "	47kΩ				
R701, 706	40143474	" " " "	470kΩ				
MINI CONNECTOR							
				J801	68060008	3024-15C	
				P801, 802	67150008	5048-15A	
				P803	68150006	3094-15A	
CAPACITOR							
C701~704	30820103	Ceramic disc	50WV 0.01μF				
C705	36226105	Tantalum	16WV 1μF				
C706	32821102	Feed thru	50WV 0.001μF				
	91001102	Seal terminal	A102	COUNTER UNIT			
				Symbol No.	Part No.	Description	
	91100008	Wrapping terminal	C		017541AZ	Counter unit assembly with Buffer Display board	
				PB-1754A	60417541	P.C. Board	
				PR-1755	60417550	P.C. Board	
SWITCH UNIT							
Symbol No.	Part No.	Description		IC & TRANSISTOR			
	017671AZ-	Switch board with components		Q907, 910	25000143	IC	MC1416
PB-1767A	60417671	P.C. Board		Q918	25000160		MC14518
				Q919	25000174		MC14519
				Q920	25000053		MSM5502
				Q912	25000067		MSM5592
		IC & TRANSISTOR		Q915, 923	25000140		SN74LS00N
Q801	25000114	IC	MC14011	Q914, 921	25000121		SN7407N
Q803	25000176		MC14016	Q917	25000072		SN74LS90N
Q802	25000156		MC14027	Q913	25000170		SN74LS102N
Q804	25000092		MC14081	Q922	25000161		SN74LS390N
Q805~808	22303730	Transistor		Q916	25000159		SP8646
Q809	21090147	Display	5082-7286	Q908	25000157		μPA56C
				Q909	25000158		μPA547C-1
				Q906	25000172		NJM78L05A
				Q926, 927, 928	22303730	Transistor	2SC373
		DIODE		Q911	22308282		2SC828
D801~806	21015550	Silicon	1S1555	Q924, 925	22390001		MPSA13
				Q901~905	21090135	Display	5082-7740
RESISTOR							
R802~806	42184103	Carbon composition	1/8W GK 10kΩ				
R801	42184473	" " " "	47kΩ				
				D901, 902, 905	21015550	Silicon	1S1555
				D903, 904	21090091	LED	SL103D
CAPACITOR							
C802	30820102	Ceramic disc	50WV 0.001μF			RESISTOR	
C801	30820473	" " " "	0.047μF	R922, 949~955	40143390	Carbon film RD1/4(F) 39Ω	
C804	33824470	Dipped mica	47PF	R924, 928, 930,	40143221	" " " 220Ω	
C803	36326685	Tantalum	20WV 6.8μF	956			
				R958	40143271	" " " 270Ω	
				R903, 908, 909,	40143102	" " " 1kΩ	
				919			
				R907, 925, 926	40143222	" " " 2.2kΩ	

PB-1894 IF-AF UNIT (No. 4..)

PB-1781 RF UNIT (No. 1..)

B.P.F. UNIT (No. 2..)

H.G. UNIT (No. 5..)

REG UNIT (No. 6..)

BUFFER AMP UNIT
PB-1790

COUNTER UNIT
PB-1754

DISPLAY UNIT PB-1755

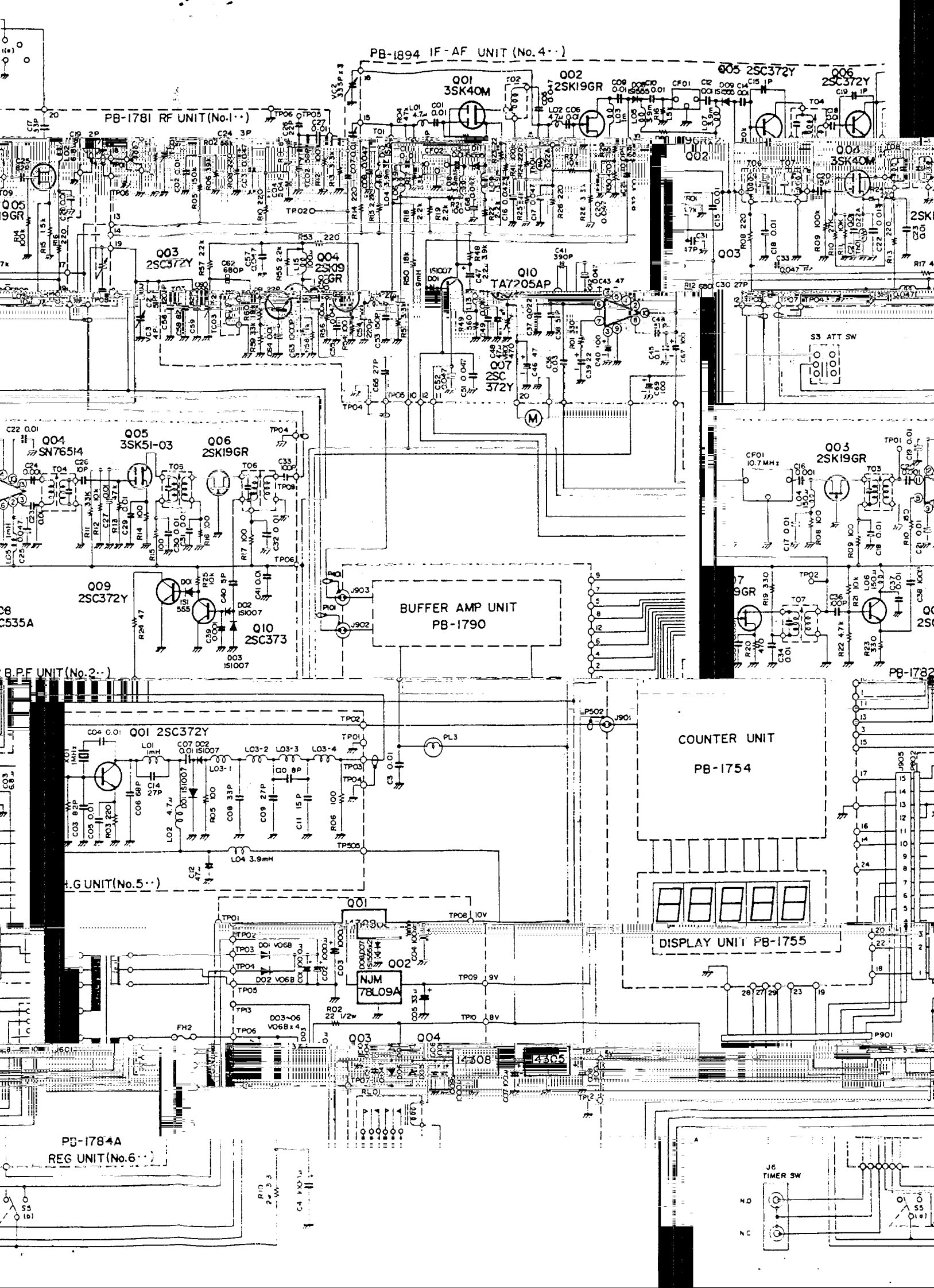

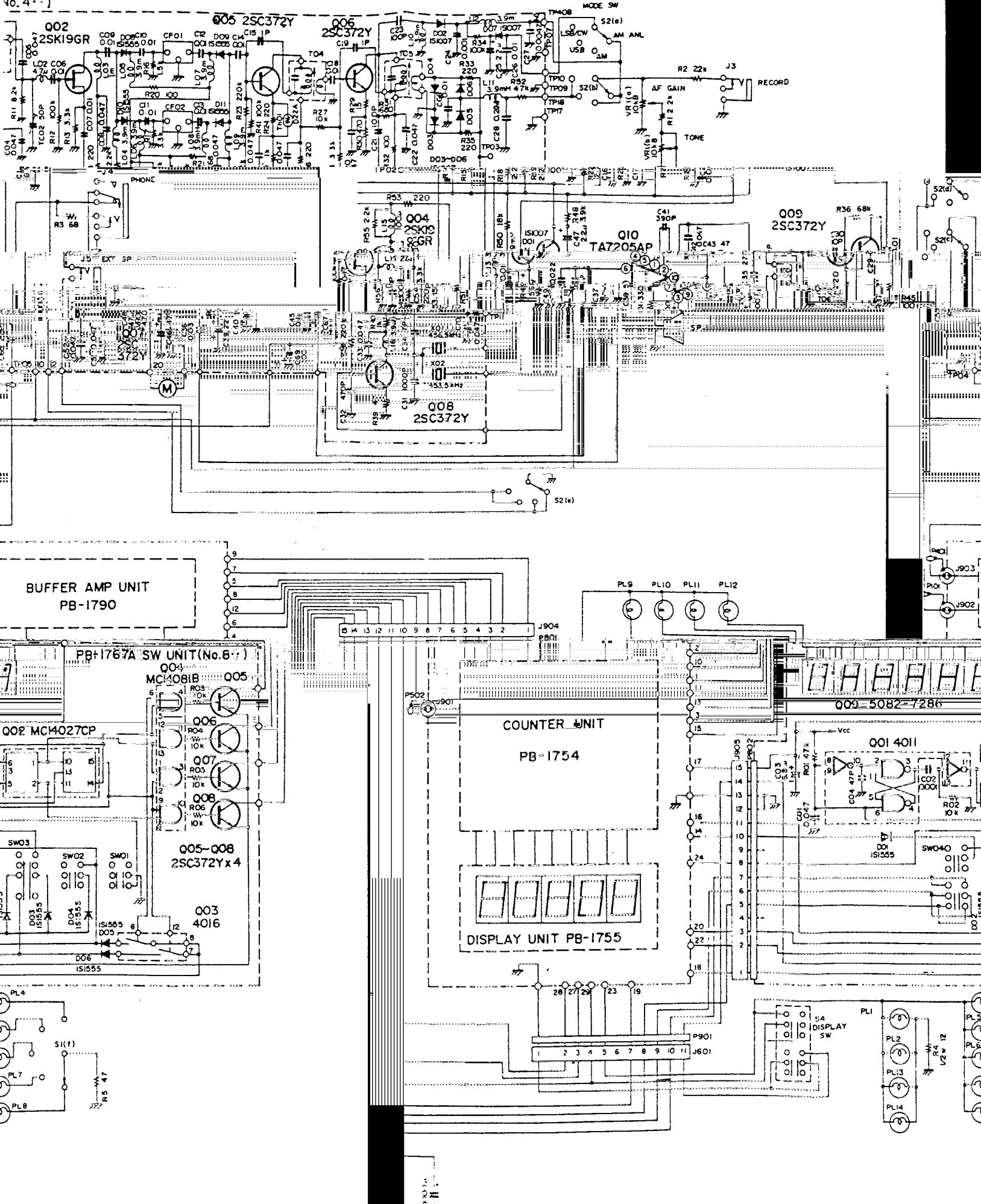

FRG-7000
CIRCUIT DIAGRAM