

TECHNICAL
MANUAL
FT-ONE



YAESU MUSEN CO., LTD.

C.P.O. BOX 1500

TOKYO, JAPAN

YAESU ELECTRONICS CORP.

P.O. BOX 49

PARAMOUNT, CALIFORNIA, 90723

PREFACE

This Technical Manual is intended to serve as a companion volume to the FT-ONE Operating Manual. It will be noted that this volume begins with Section 2. The material covered in the Operating Manual, composing Section 1, is intended to provide general information, specifications, notes on accessories and installation, and operating instructions for the FT-ONE. These subjects are not covered again in this manual.

This purpose of this Technical Manual is to provide the reader with information critical to the maintenance and repair of the FT-ONE transceiver, as well as information useful for understanding its functions and operation more thoroughly. Technical explanations are geared toward providing a clear understanding of the overall system design, rather than attempting to cover many specific circuit details. Therefore descriptions have been kept brief, although photographs and drawings are utilized liberally.

Use of this manual is entirely at the owner's risk. The FT-ONE uses high quality components and a design and construction intended to last a long time without the need for alignment or servicing. Should the reader discover any errors in this manual, however, we invite any corrections; although Yaesu can not assume liability for damage which may occur when this manual is used as a reference.

Your attention to the note below is requested.

Yaesu Musen Company, Ltd.
Tokyo

Copyright © 1982
Yaesu Musen Co., Ltd.
All Rights Reserved

No portion of this Manual
may be reproduced in any
form without written permission
of Yaesu Musen Co., Ltd.

SECTION 2—TECHNICAL NOTES

BLOCK DIAGRAM	2-1
CIRCUIT DESCRIPTION	2-7
PLL CIRCUIT FREQUENCY RELATIONSHIPS	2-13
FREQUENCY RELATIONSHIPS	2-14
FREQUENCY RANGE MODIFICATION	2-15
QSK LINEAR AMPLIFIER MODIFICATION	2-17
RECEIVER STABILITY IMPROVEMENT MODIFICATIONS	2-18

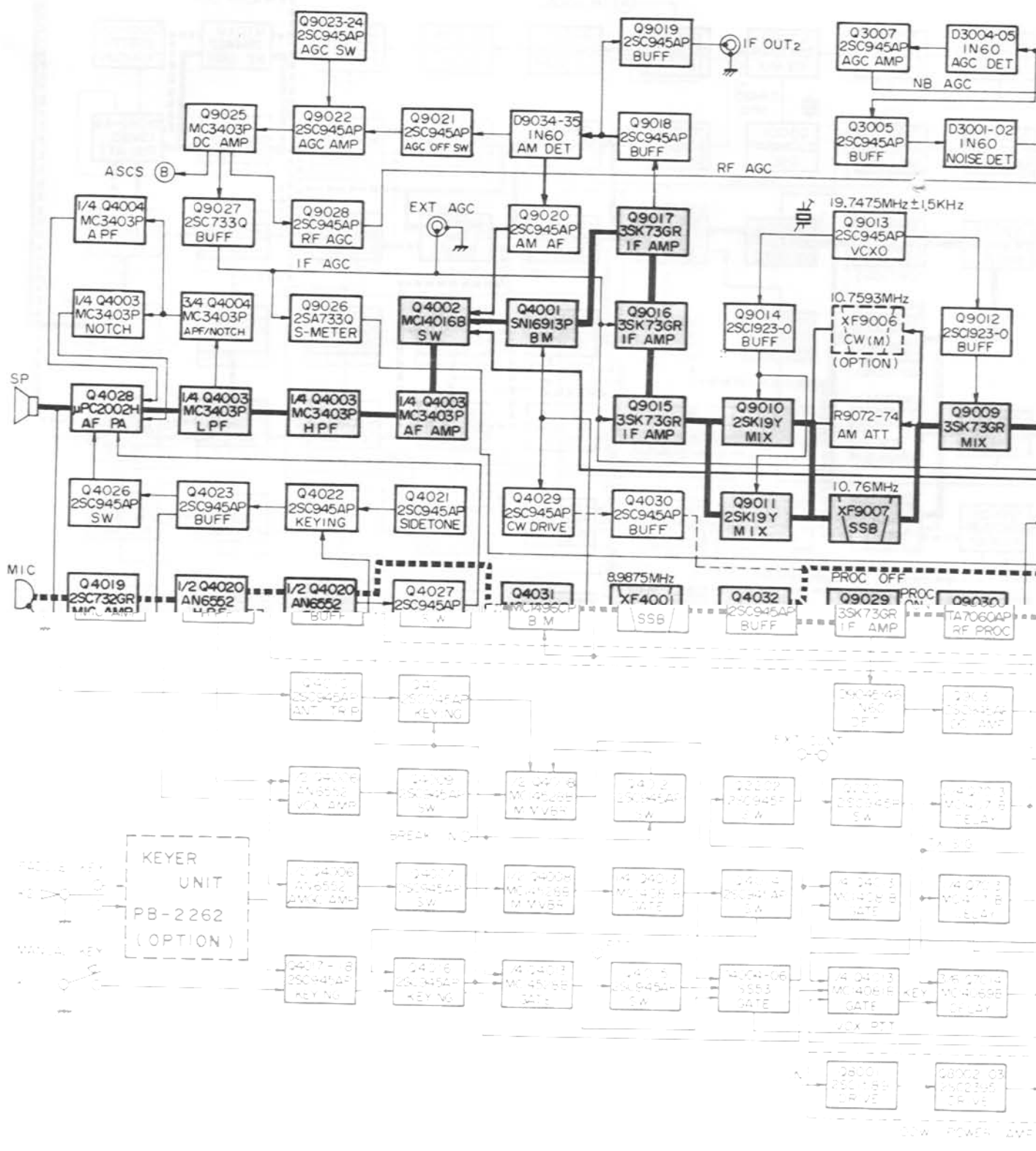

SSB MOD

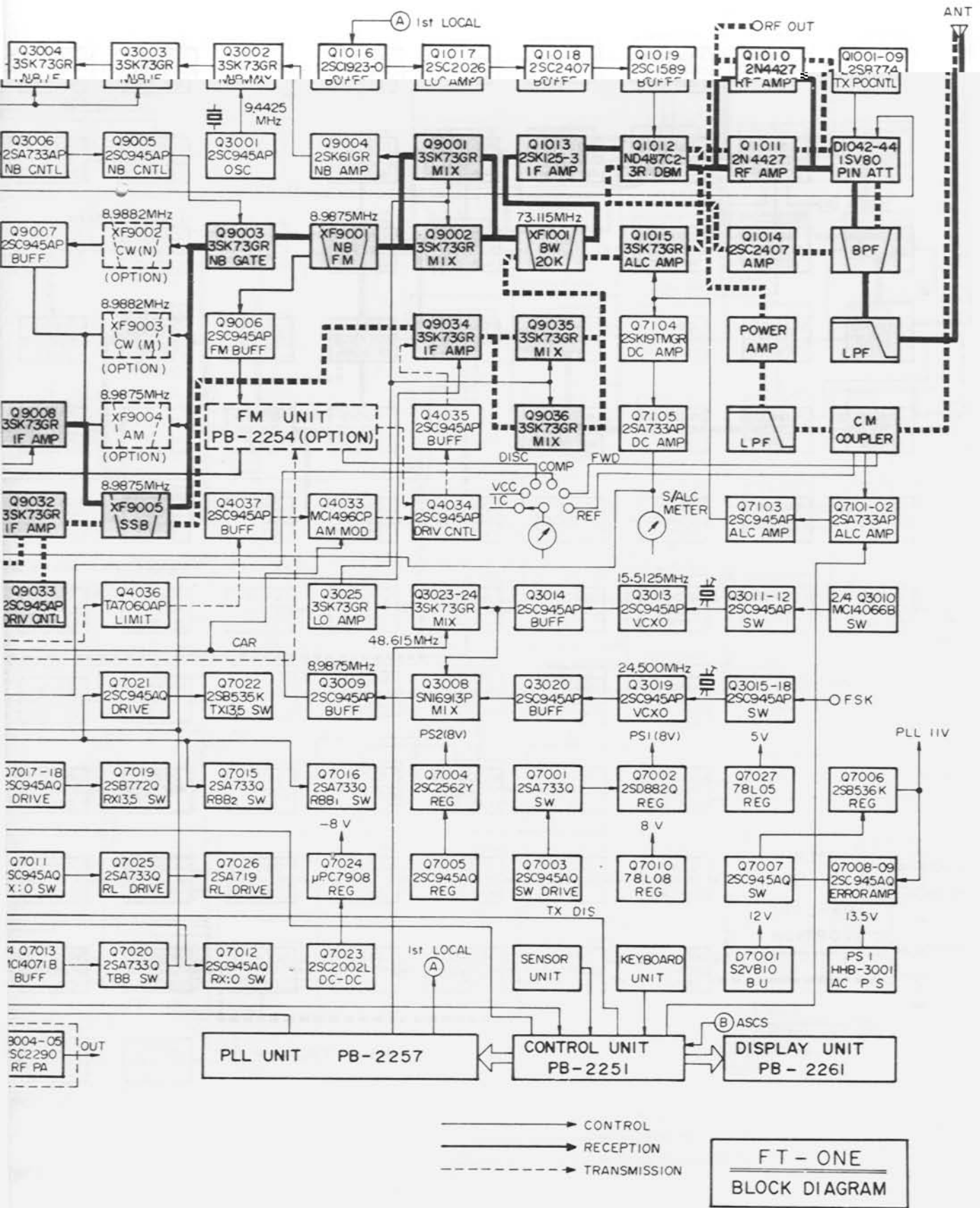

FT - ONE
BLOCK DIAGRAM

TECHNICAL NOTES

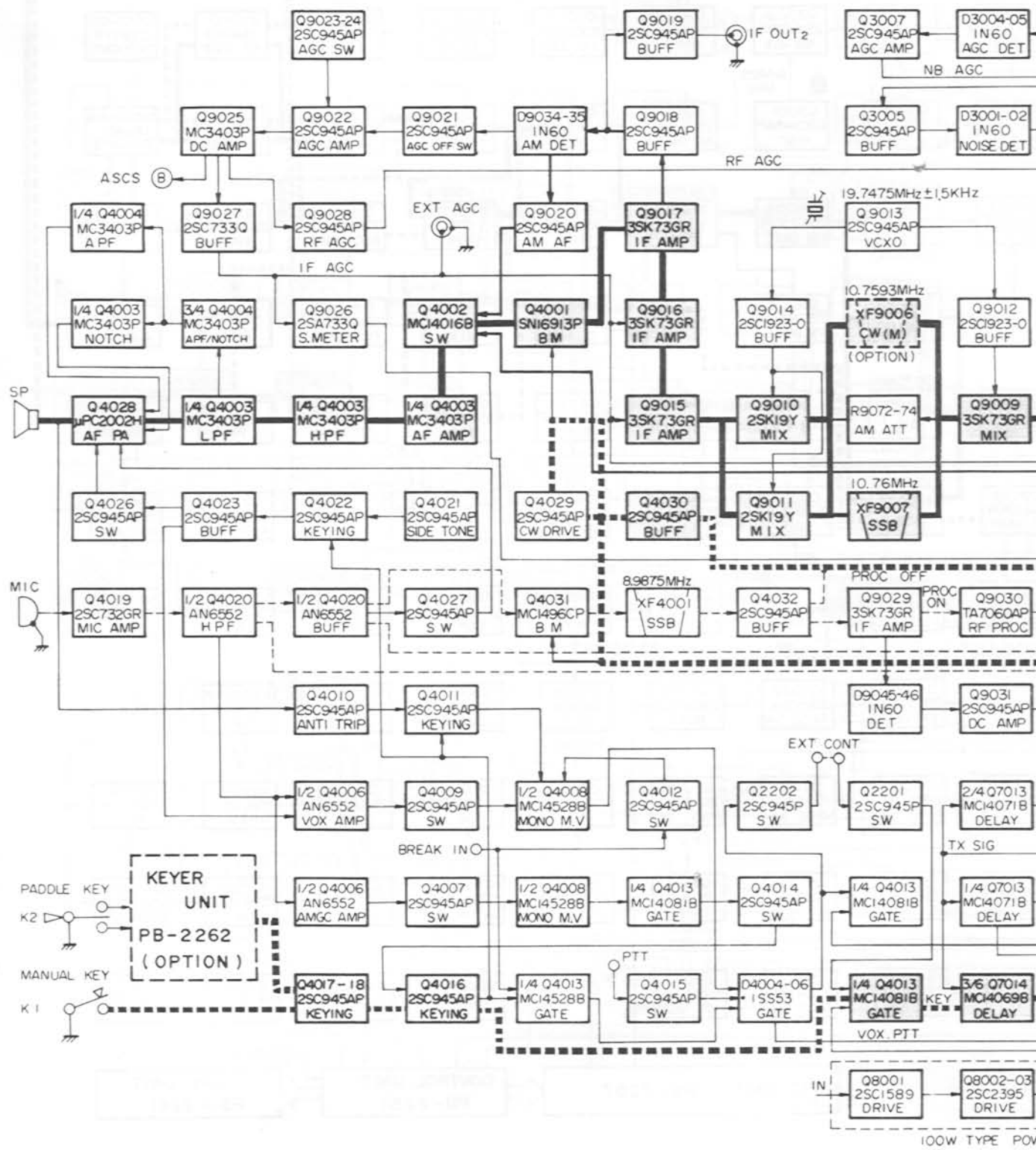

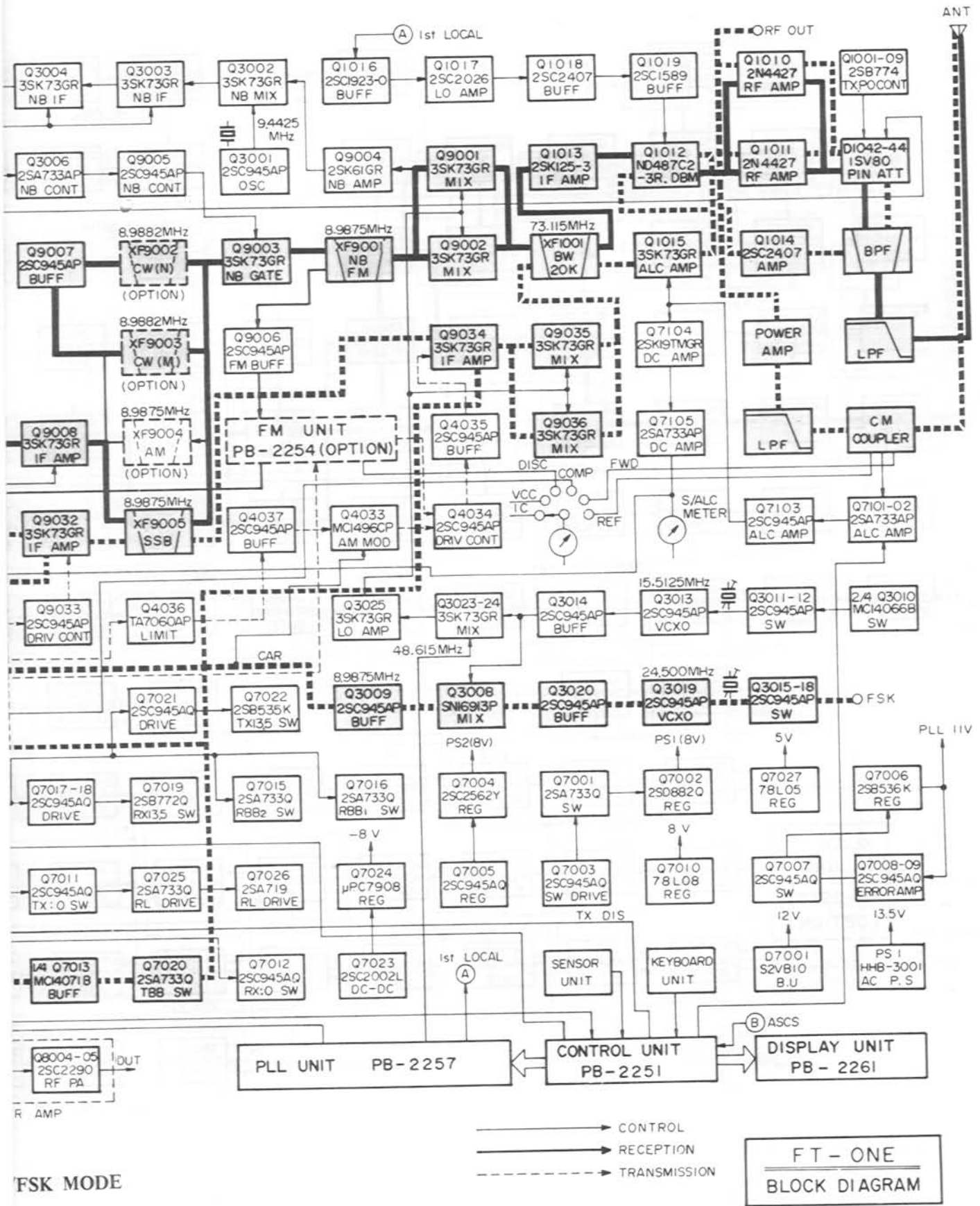

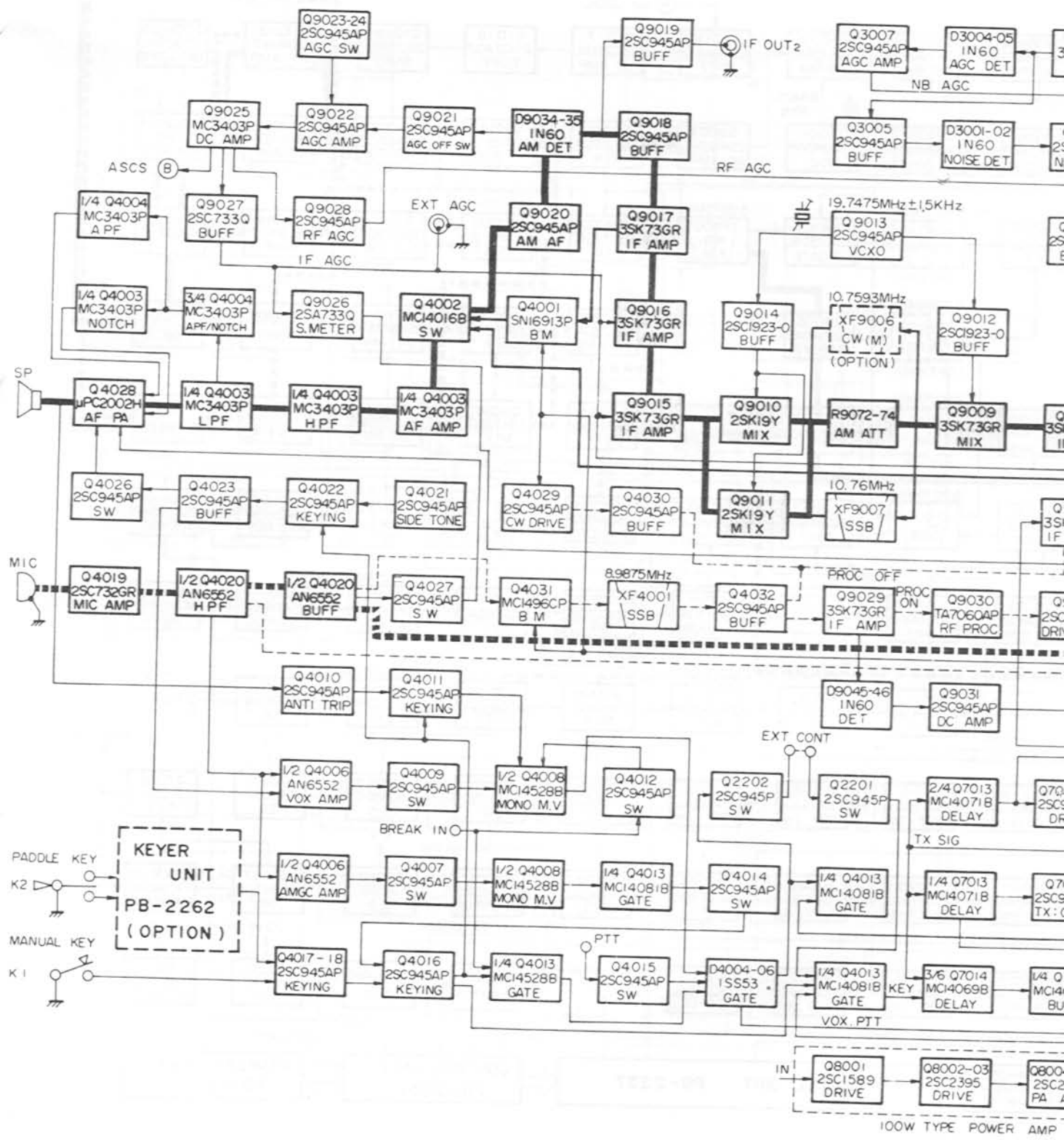

3-
MAR 1962

AM MODE

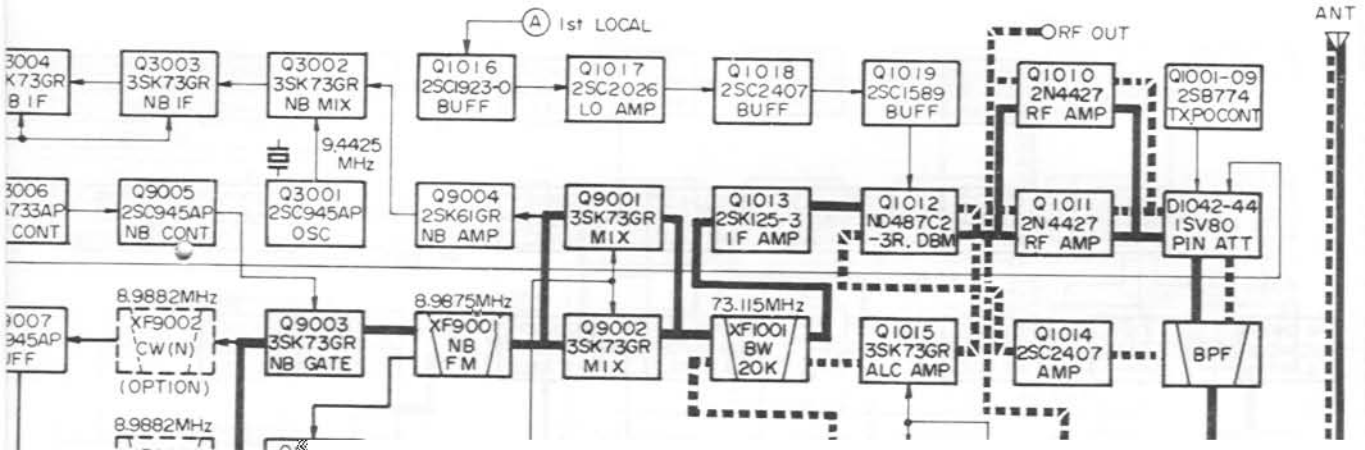

TECHNICAL NOTES

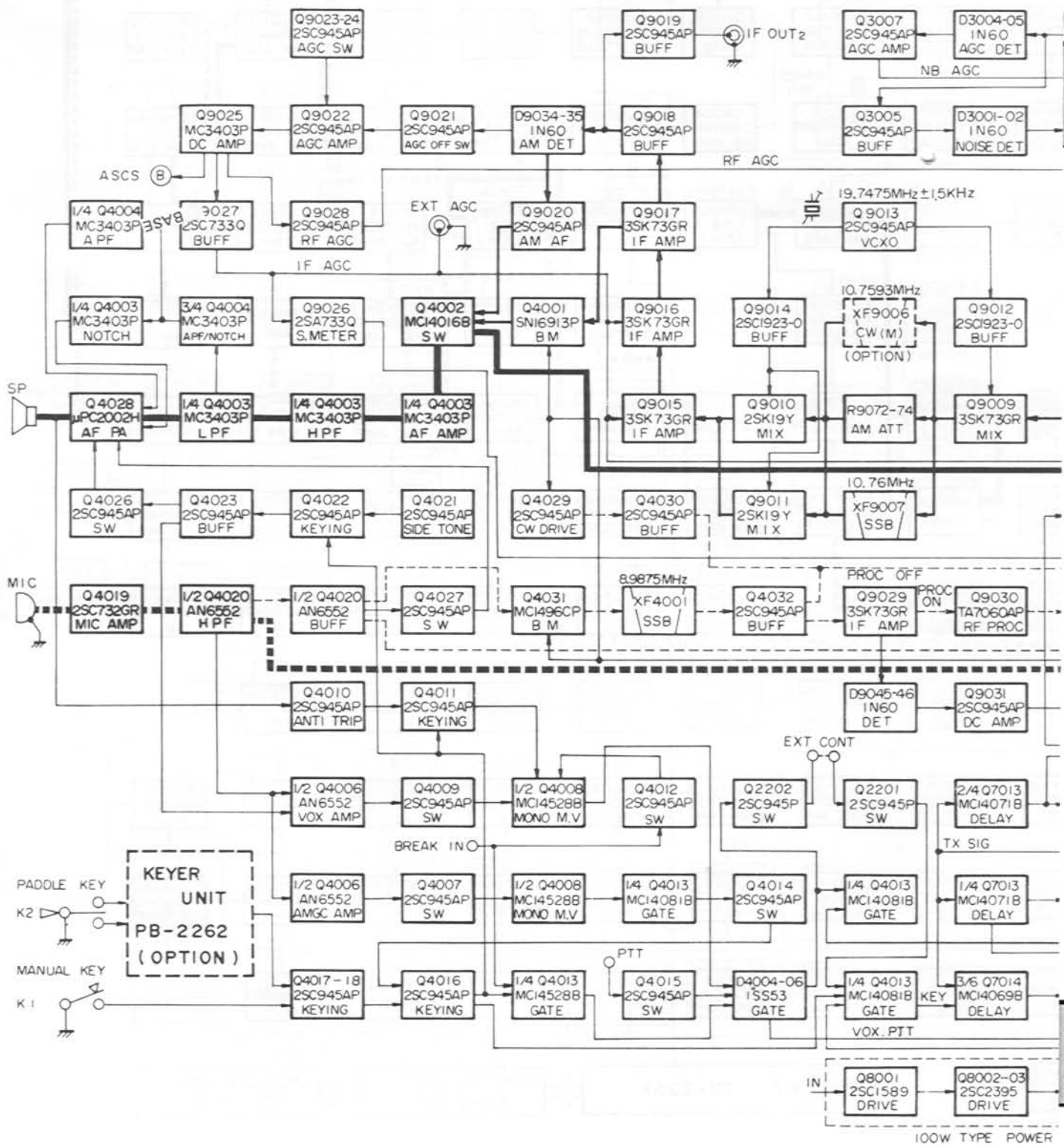

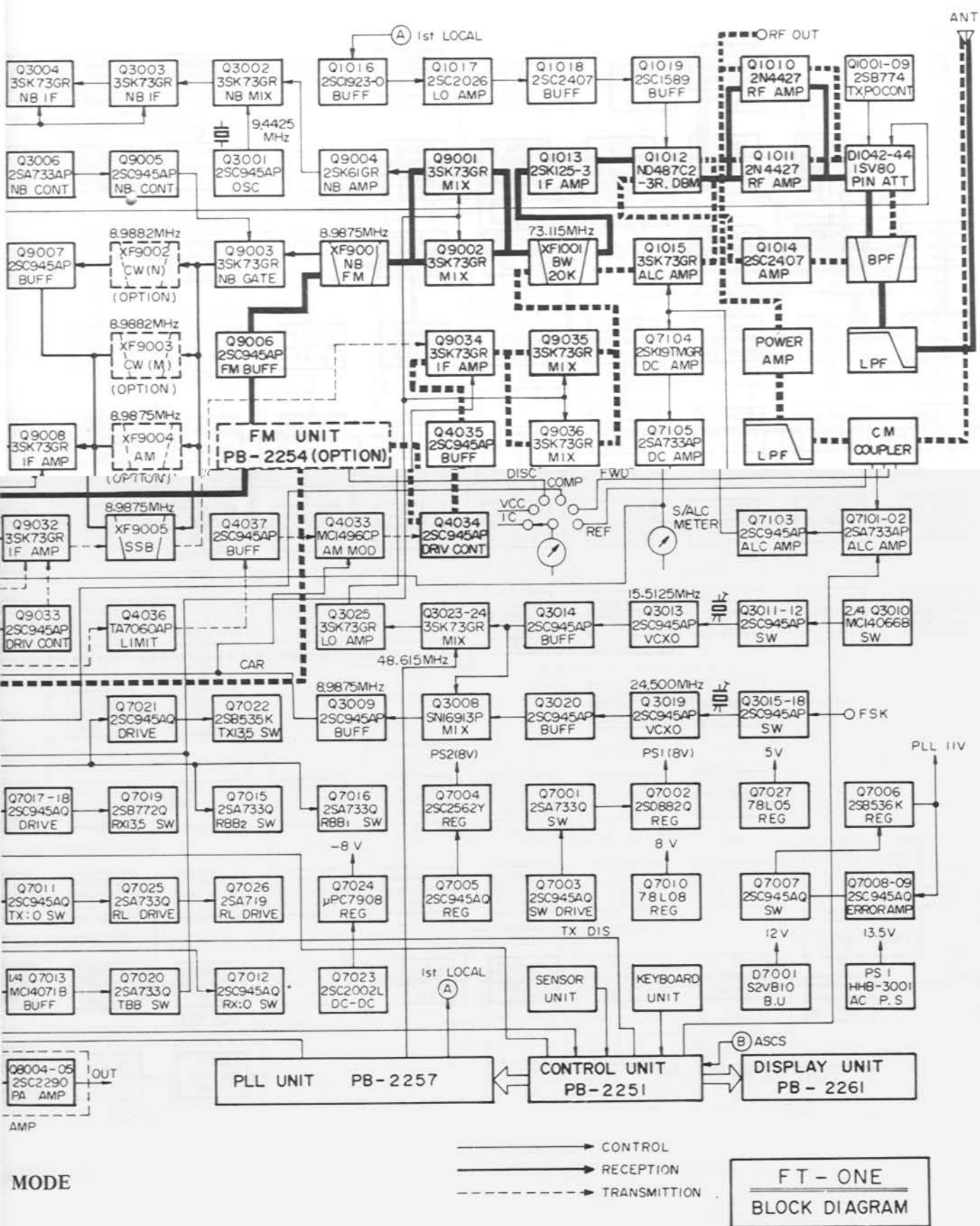

MODE

- CONTROL
- RECEPTION
- - - TRANSMISSION

FT - ONE
BLOCK DIAGRAM

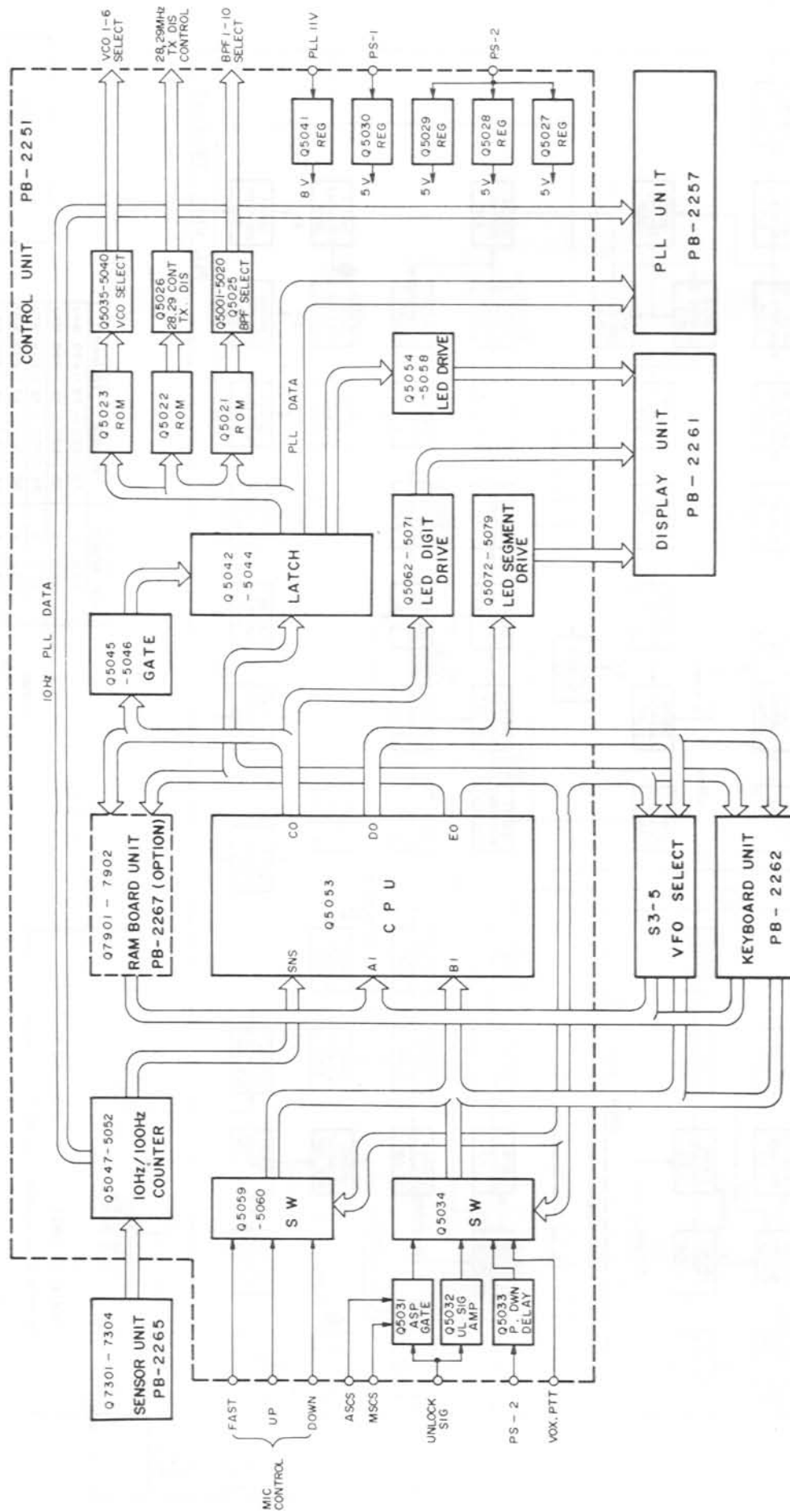

FT - ONE
CONTROL BLOCK DIAGRAM

CIRCUIT DESCRIPTION

If you intend to secure the full potential of the high technology design of the FT-ONE a clear understanding of the functions of the various circuits of the transceiver is helpful.

The FT-ONE circuitry incorporates a new type of design in which a microprocessor is used to control many of the circuits in a manner that may not be familiar to the operator. The block diagrams, together with the following circuit descriptions, will provide you with a better understanding of the design of the FT-ONE. Refer to the schematic diagrams for specific component details. The following circuit descriptions apply to the fully equipped FT-ONE.

RECEIVER

The RF signal from the antenna connects to the ALC Unit (PB-2260) where it is passed through antenna relay RL₇₁₀₁, and then a low-pass filter and a lamp fuse, after which it is passed through the jumper between the RCV-1 and RCV-2 jacks on the rear panel. From RCV-2 the RF signal is delivered to the RF Unit (PB-2256).

RF Unit (PB-2256)

The RF signal passes through impedance transformer T₁₀₀₁ where the 50 ohm input impedance is converted to 200 ohms, and then fed through a diode switch to one of the ten band-pass filters selected by the receive frequency data from the microprocessor. From the band-pass filter the impedance is transformed at T₁₀₀₂ back to 50 ohms and this signal is fed to the PIN diode attenuator, consisting of D₁₀₄₂, D₁₀₄₃ and D₁₀₄₄ (1SV77); and on to the push-pull RF amplifier; Q₁₀₁₀ and Q₁₀₁₁ (2N4427). The signal then passes through a resistive attenuator to present exactly 50 ohms to the mixer circuit, consisting of three transformers and Schottky-barrier diode module Q₁₀₁₂ (ND487C2-3R), where the signal is heterodyned with the local signal delivered from the local amplifier, resulting in a first IF frequency of 73.155 MHz. (See PLL description for details of local signal derivation.)

From the first mixer the first IF signal is fed through JFET post-amplifier Q₁₀₁₃ (2SK125-3) to 20 kHz BW, 4-pole crystal band-pass filter XF₁₀₀₁, after which it is delivered to the IF Unit (PB-2255).

IF Unit (PB-2255)

The filtered first IF signal is fed to singly-balanced second mixer Q₉₀₀₁ and Q₉₀₀₂ (3SK73GR), where it is heterodyned with the second local signal to produce the 8.9875 MHz second IF. The frequency of the second local signal is determined by the mode of operation and the IF Shift function, and is approximately 64 MHz. The second IF signal from the second mixer is passed through 20 kHz BW, 4-pole crystal filter XF₉₀₀₁, except for a portion of this signal, which is diverted to noise blanker buffer Q₉₀₀₉ (2SK61GR) and passed to the noise blanker circuit. The signal from the crystal filter is amplified by Q₉₀₀₃ (3SK73GR), which also serves as the noise blanker gate.

The signal is now passed through one of the 8-pole crystal filters determined by the mode of operation selected (SSB XF₉₀₀₅ is standard, AM XF₉₀₀₄, CW-M XF₉₀₀₃ and CW-N XF₉₀₀₂ are options), to amplifier Q₉₀₀₈ (3SK73GR): with the exception of the signal from the CW-N crystal filter, which is first amplified by Q₉₀₀₇ (2SC945AP) to compensate for the greater insertion loss of the narrow bandwidth filter. From Q₉₀₀₈ the signal is applied to first width mixer Q₉₀₀₉ (3SK73GR), where it is heterodyned with the 19.7475 MHz (± 1.5 kHz) signal from width oscillator Q₉₀₁₃ (2SC945AP) and crystal X₉₀₀₁, via buffer Q₉₀₁₂ (2SC1923-O).

From the first width mixer the 10.76 MHz signal is fed through the second IF filter; XF₉₀₀₇ for SSB (and for CW and FSK if the optional filter is not installed), XF₉₀₀₆ for CW-M, CW-N, and FSK-N (if installed), or through an attenuator network for AM. Now the signal is fed to second width mixer Q₉₀₁₀ and Q₉₀₁₁ (2SK19TMY), where it is heterodyned again with the width oscillator signal—this time through buffer Q₉₀₁₄ (2SC1923-O). From this second width mixer the 8.9875 MHz signal passes through three stages of IF amplification provided by Q₉₀₁₅, Q₉₀₁₆, and Q₉₀₁₇ (3SK73GR).

A portion of the output of Q₉₀₁₇ is fed through buffer Q₉₀₁₈ (2SC945AP) to AM detectors D₉₀₃₄ and D₉₀₃₅ (1N60), and through buffer Q₉₀₁₉ (2SC945AP) to provide a signal for an external monitor scope. A portion of the signal from the AM detector is amplified by AGC amplifier Q₉₀₂₂ (2SC945AP), which can be switched off by Q₉₀₂₁ (2SC945AP). The AGC rate is switched by Q₉₀₂₃ and Q₉₀₂₄ (2SC945AP) controlling time constant networks R₉₁₃₅ C₉₁₃₄ and R₉₁₃₂ C₉₁₃₅ respectively. The AGC signal from Q₉₀₂₂ is fed to quad differential input op amp Q₉₀₂₅ (MC3403P), from where it is applied to the RF and IF amplifiers, the scanner circuitry (for automatic scan stop) and the S-meter.

The remainder of the signal from the AM detector passes through buffer Q₉₀₂₀ (2SC945AP) and is delivered to the AF Unit (PB-2252). The remainder of the IF amplifier output from Q₉₀₁₇ is also delivered to the AF Unit for SSB, CW, and FSK detection.

AF Unit (PB-2252)

The IF signal from the IF Unit is applied to the active product detector IC, Q₄₀₀₁ (SN16913P), where it is mixed with the carrier oscillator signal and the audio frequencies are detected. The frequency of this carrier oscillator signal is determined by the mode selected and the IF shift. The SSB, CW, or FSK signal from the product detector is then fed to one gate of analog switch Q₄₀₀₂ (MC14016BCP), whose other gates are fed by the detected AM signal and the detected FM signal and whose control gates are selected by the MODE switch.

The output from the selected gate is amplified by one section of quad op amp Q₄₀₀₃ (MC3403P), and then fed through a high-pass filter (another section of Q₄₀₀₃), and a low-pass filter (third section), where a portion of the signal is diverted to the NOTCH/APF circuitry. The remainder of the signal from the low-pass filter section is fed directly to the audio power amplifier, Q₄₀₂₈ (μ PC2002H), and from there to the speaker. When the NOTCH/APF is activated, the signal from the third section of Q₄₀₀₃ is fed through the audio band-pass filter circuit composed of the remaining quarter of Q₄₀₀₃ and the four op amp sections of Q₄₀₀₄ (MC3403P) before being fed to the audio power amplifier.

Noise Blanker (part of IF Unit (PB-2255) and Local Unit (PB-2253))

A portion of the 8.9875 MHz signal before the second mixer is amplified by JFET Q₉₀₀₄ (2SK-61GR) on the IF Unit and delivered to noise blanker mixer Q₃₀₀₂ (3SK73GR) on the Local Unit, where it is heterodyned with the 9.4424 MHz signal from the noise blanker local oscillator, Q₃₀₀₁ (2SC945AQ), and crystal X₃₀₀₁. The 455 kHz product from the mixer is amplified by Q₃₀₀₃ and Q₃₀₀₄ (3SK73GR), after which a portion of the signal is rectified by noise blanker AGC diodes D₃₀₀₄ and D₃₀₀₅ (1N60), amplified by Q₃₀₀₇ (2SC-945AP), and fed back to Q₃₀₀₃ and Q₃₀₀₄.

The remainder of the signal from Q₃₀₀₄ is amplified by Q₃₀₀₅ (2SC945AP) and then rectified by diodes D₃₀₀₁ and D₃₀₀₂ (1N60). The DC output from these diodes is amplified by Q₃₀₀₆ (2SA733AP) and delivered back to the IF Unit, where it is buffered by Q₉₀₀₅ (2SC945AP) and fed to noise gate MOSFET Q₉₀₀₃ (3SK73GR) just after first 9 MHz crystal filter XF₉₀₀₁.

FM Unit (PB-2254, option)

A portion of the 8.9875 MHz second IF signal from crystal filter XF₉₀₀₁ is buffered by Q₉₀₀₆ (2SC945AP) before being delivered from the IF Unit to the FM Unit, when installed. On the FM Unit this received signal is then buffered by Q₂₁₀₁ (2SC1674L) and applied to mixer Q₂₁₀₂ (2SK-19TMGR), which also receives a 9.4425 MHz local signal generated by crystal oscillator Q₂₁₀₅ (2SC-945AP). The resulting 455 kHz output from Q₂₁₀₂ is passed through ceramic filter CF₂₁₀₁ and then amplified by Q₂₁₀₃ (2SC945AP) and limiting amplifier Q₂₁₀₄ (μ PC577H), where the amplitude variations on the filtered signal are removed. Output from Q₂₁₀₄ is applied through ceramic discriminator CD₂₁₀₁ and diode detectors D₂₁₀₁ and D₂₁₀₂ (1S188FM) to result in an audio output corresponding to frequency variations of the 455 kHz input. This audio is then amplified by Q₂₁₁₁ (2SC945AP) and delivered to analog switch Q₄₀₀₂ on the AF Unit for final audio amplification and output.

When no carrier is present to quiet the 455 kHz IF, noise present in the audio output from discriminator diodes D_{2101} and D_{2102} is passed through a high-pass filter and the Squelch control on the front panel, before amplification at Q_{2108} (2SC-945AQ) and one half of Q_{2109} (AN6552). The amplified noise is then detected by D_{2105} and D_{2106} (1S188FM), and the resulting DC is applied to Q_{2110} (2SC945AP), which grounds the base of Q_{2111} to prevent audio output to the AF Unit when no carrier is present.

A sample of the output from D_{2101} and D_{2102} is diverted through meter level trimmer VR_{2103} to the remaining half of Q_{2109} , which amplifies the discriminator output sample for discriminator center tuning indication on METER I. Regulated plus 8 volts for Q_{2109} is derived from the FM plus 13.5 V bus by Q_{2106} (2SC1959Y) and Q_{2107} (2SC945), and zener diodes D_{2103} (RD9.1EB2) and D_{2104} (RD8.2EB3).

TRANSMITTER

SSB

From the microphone or patch input the speech signal is amplified by Q_{4019} (2SC732TMGR) on the AF Unit (PB-2252) and fed through the active high-pass filter, one half of dual op amp Q_{4020} (AN6552); and buffered by the other half of Q_{4020} . The signal is now applied to balanced modulator Q_{4031} (MC1496CP), where it modulates the 9 MHz carrier signal from carrier buffer Q_{3009} (2SC945AP) on the Local Unit. The modulated sidebands are now fed into sideband filter XF_{4001} where the unwanted sideband is rejected. The remaining single sideband signal is then buffered by Q_{4032} (2SC945AP) and one portion delivered to the speech processor circuit on the IF Unit. The remaining portion of the signal is delivered directly to IF amplifier Q_{9032} (3SK73GR) when the speech processor is switched off.

When the speech processor is on the signal is amplified by Q_{9029} (3SK73GR) and fed to RF clipper Q_{9030} (TA7060AP), from where it is passed through drive control buffer Q_{9033} (2SC945AP) to IF amplifier Q_{9032} (mentioned above). A sample of the compression signal at Q_{9029} is rectified by diodes D_{9045} and D_{9046} , amplified by Q_{9031} (2SC945AP) and delivered to METER I for the COMP indication.

From IF amplifier Q_{9032} the signal is passed through SSB crystal filter XF_{9005} and IF amplifier Q_{9034} (3SK73GR) to first transmit mixer Q_{9035} and Q_{9036} (3SK73GR), where it is heterodyned with the 64 MHz signal from the LO. The 73 MHz product of the mixer is delivered to the RF Unit and fed through 20 kHz BW filter XF_{1001} and ALC amplifier Q_{1015} (3SK73GR) to mixer Q_{1012} (ND487C2-3R). Here the signal is heterodyned with the first local signal from the local amplifier, and the product at the desired output frequency is then amplified by Q_{1014} (2SC2407) and passed through one of the nine band-pass filters and the PIN diode attenuator, D_{1042} through D_{1044} , to equalize the output level of the final amplifier for each band.

From the attenuator the signal is amplified by RF amplifier transistors Q_{1010} and Q_{1011} (2N4427), which are used as the RF amplifier in receive, to deliver 100 mW to the 100 W PA Unit (PB-2321). Here the signal is amplified by Q_{8001} (2SC1589), followed by push-pull drivers Q_{8002} and Q_{8003} (2SC2395), and final push-pull power amplifiers Q_{8004} and Q_{8005} (2SC2290); and then delivered through the narrow-band pass filter in the LPF Unit (PB-2259), the directional coupler L_{7101} , and antenna relay RL_{7101} on the ALC Unit (PB-2260) to the antenna.

CW

On the Local Unit (PB-2253), 24.4992 MHz crystal oscillator Q_{3019} (2SC945AP), whose frequency can be shifted by switches Q_{3015} through Q_{3018} (2SC945AP) controlled by FSK keying, has its output buffered by Q_{3020} (2SC945AP) before being fed to balanced mixer Q_{3008} (SN16913P). Also fed to the mixer is the shift and carrier oscillator signal of 15.5110 MHz generated at Q_{3013} (2SC945AP), switch shifted by Q_{3011} and Q_{3012} (2SC945AP), and two sections of Q_{3010} (MC-14066BCP); and buffered by Q_{3014} (2SC945AP).

The 8.9882 MHz resultant output of mixer Q_{3008} is then buffered by Q_{3009} (2SC945AP) and delivered to CW drive amplifier Q_{4029} (2SC945AP) on the AF Unit (PB-2252). After this the signal is buffered by Q_{4030} (2SC945AP) and delivered to IF amplifier Q_{9032} on the IF Unit before being filtered by crystal filter XF_{9005} . The remainder of the signal path for the CW signal is identical to that of the SSB signal already described.

FSK

The FSK keying signal is applied to crystal oscillator Q₃₀₁₉ via switches Q₃₀₁₅ through Q₃₀₁₈, which cause the oscillator to produce a 24.502125 MHz signal for MARK and a 24.502295 MHz signal for SPACE. Shift and carrier oscillator Q₃₀₁₃ is directed through switches Q₃₀₁₁, Q₃₀₁₂ and two sections of Q₃₀₁₀ (controlled via the mode switch) to generate a signal at 15.5140 MHz. These are mixed to produce the carrier, filtered, and amplified in the same manner as CW.

AM

The audio signal from the microphone is amplified by Q₄₀₁₉ (2SC732TMGR) on the AF Unit (PB-2252) and fed through the high-pass filter, 1/2Q₄₀₂₀ (AN6552), and through the buffer composed of the other half of Q₄₀₂₀; from where it is passed to limiter Q₄₀₃₆ (TA7060AP). The signal is then buffered by Q₄₀₃₇ (2SC945AP) and fed to AM modulator Q₄₀₃₃ (MC1496CP). From the modulator the signal is fed through drive control amplifier Q₄₀₃₄ (2SC945AP) and buffer Q₄₀₃₅ (2SC945AP) before being fed to IF amplifier Q₉₀₃₄ (3SK73GR) on the IF Unit (PB-2255). The signal path is then the same as for SSB, with appropriate changes in the oscillator frequencies by the CPU to provide the correct LO signals at the mixers.

FM

After amplification and high-pass filtering, the speech signal is delivered from Q₄₀₂₀ on the AF Unit to Q₂₁₁₂ (2SC945AP) on the FM Unit (PB-2254). Pre-emphasis is applied at Q₂₁₁₂ via C₂₁₅₀ and R₂₁₅₂, and the signal is then amplified by Q₂₁₁₃ (2SC945AP) and clipped at D₂₁₀₇ and D₂₁₀₈ (1SS53) to remove any amplitude peaks that would cause overdeviation. After clipping the signal is filtered at Q₂₁₁₄ (2SC945AP) and buffered by Q₂₁₁₅ for application through deviation trimmer VR₂₁₀₅ to modulating varactor D₂₁₀₉ (FC63). D₂₁₀₉ is located in the 8.9875 MHz VCXO circuit composed also of crystal X₂₁₀₂ and Q₂₁₁₆ (2SC945AP), which is frequency modulated by the audio voltage on D₂₁₀₉. The resulting output is buffered by Q₂₁₁₇ and delivered from FM drive control VR₂₁₀₆ to Q₄₀₃₄ on the AF Unit, from where the signal follows the same path as that for

AM transmission. Regulator Q₂₁₁₈ (μPC78L08) provides a separate 8 volt supply for the VCXO from the 13.5 VDC FM transmit bus.

VOX, AMGC

A portion of the signal from the high-pass filter 1/2Q₄₀₂₀ (AN6552) for the microphone audio on the AF Unit (PB2252) is fed to both halves of Q₄₀₀₆ (AN6552). One half is used for the VOX amplifier, which controls switch Q₄₀₀₉ (2SC945AP), which in turn triggers one half of dual monostable multivibrator Q₄₀₀₈ (MC14538BCP), also fed by the Break-in command from the front panel switch through switch Q₄₀₁₂ (2SC945AP) and by the anti-trip signal from the speaker through anti-trip switch Q₄₀₁₀ and keying switch Q₄₀₁₁ (both 2SC945AP) keyed by Q₄₀₁₆. The output of this half of Q₄₀₀₈ is fed to the D₄₀₀₄ through D₄₀₀₆ diode gate (mentioned in the keying circuit description).

The remaining half of Q₄₀₀₆ is the AMGC amplifier, which feeds through switch Q₄₀₀₇ (2SC945AP) to the other half of Q₄₀₀₈, the other monostable multivibrator. The output of this monostable is fed through one gate of Q₄₀₁₃, a quad AND gate (MC14081B), and then switch Q₄₀₁₄ (2SC945AP) to third keying switch Q₄₀₁₆ (2SC945AP), mentioned in the keying circuit description.

KEYING

The keying command gate is one section of quad AND gate Q₄₀₁₃ (MC14081BCP) on the AF Unit (PB-2252). This gate is keyed by the signal from keying transistors Q₄₀₁₆, Q₄₀₁₇ and Q₄₀₁₈ (all 2SC945AP) which are fed by the Manual Key or optional Keyer Unit (PB-2262). The keying signal from Q₄₀₁₃ is then delivered to the Regulator Unit (PB-2258), where 3/6 of hex inverter Q₇₀₁₄ (MC14069UBCP) are used to delay the keying signal before passing through 1/4 of quad buffer Q₇₀₁₃ (MC14071BCP) to Transmit Bias Switch Q₇₀₂₀ (2SA733Q).

A portion of the signal from keying transistor Q₄₀₁₆ on the AF Unit is fed to another 1/4 of quad AND gate Q₄₀₁₃, which is also fed by the Break-in control switch from the front panel, and which switches the diode gate D₄₀₀₄, D₄₀₀₅,

and D₄₀₀₆ (1SS53); along with the PTT signal through Q₄₀₁₅ (2SC945AP) and the VOX signal mentioned earlier. This diode gate delivers the VOX/PTT signal to the Control Unit (PB-2251), and also feeds a signal through switches Q₂₂₀₂ and Q₂₂₀₁ (2SC945P) connected together by a jumper at the External Control Unit (PB-2238) to the keying command gate of Q₄₀₁₃ mentioned above.

This signal from the diode gate is also limited at another ¼ of Q₄₀₁₃ by the TX DISABLE command from the Control Unit. The keying command gate portion of Q₄₀₁₃ also has a third input from the PLL Unit (PB-2257). Additional keying-related circuitry is covered in the RX MUTE/TX DELAY circuit description.

SIDETONE

Sidetone oscillator Q₄₀₂₁ (2SC945AP) on the AF Unit (PB-2252) feeds its signal through sidetone keying switch Q₄₀₂₂ (2SC945AP) (keyed by a portion of the output of the third keying transistor, Q₄₀₁₆) and buffer Q₄₀₂₃ (2SC945AP) to both the VOX amplifier portion of Q₄₀₀₆ and switch Q₄₀₂₆ (2SC945AP). Q₄₀₂₆ then passes the sidetone signal on to AF power amplifier Q₄₀₂₈.

RECEIVER MUTE, TRANSMIT DELAY (QSK)

From the Control Unit (PB-2251) the TX Signal switching command is delivered to the sequential delay gates on the Regulator Unit (PB-2258), composed of quad OR gate Q₇₀₁₃ (MC14071B), and also the same half of hex inverter Q₇₀₁₄ mentioned earlier in the Keying Circuit description controlling the Transmit Bias switching. Of Q₇₀₁₃'s delay gates, one set controls the Transmit Zero Voltage Reference Switch, Q₇₀₁₁ (2SC945AQ), which in turn controls Relay Drivers Q₇₀₂₅ (2SA733Q) and Q₇₀₂₆ (2SA719Q) to the antenna relay. This set of gates also controls the Receiver Zero Voltage Reference Switch, Q₇₀₁₂ (2SC945AQ).

The other set of delay gates in Q₇₀₁₃ controls drivers Q₇₀₁₇ and Q₇₀₁₈ (2SC945AQ) to Receiver 13.5V Switch Q₇₀₁₉ (2SB772Q); driver Q₇₀₂₁ (2SC945AQ) to Transmitter 13.5V Switch Q₇₀₂₂ (2SB536K); Receiver Bias Switch 1, Q₇₀₁₆ (2SA733Q); and Receiver Bias Switch 2, Q₇₀₁₅ (2SA733Q).

REGULATOR UNIT (PB-2258)

In addition to the Mute and Delay circuitry, the Regulator Unit contains the minus 8 V supply, derived from 13.5 V through DC-DC Converter Q₇₀₂₃ (2SC2002L) and Regulator Q₇₀₂₄ (MC7908CT). The 13.5 VDC output of Power Supply Unit PS1 is also fixed by Regulator Q₇₀₂₇ (µPC78L05) to provide plus 5 V, by Q₇₀₁₀ (µPC78L08) to provide plus 8 V, through Power Switch S₂ to Switch Driver Q₇₀₀₃ (2SC945AQ) to Switch Q₇₀₀₁ (2SA733Q) and then to Regulator Q₇₀₀₂ (2SD882Q) to provide plus 8 V; and also through Switch Q₇₀₀₇ (2SC945AQ) to Regulator Q₇₀₀₆ (2SB536K) providing plus 11 V to the PLL, a portion of which is fed through an Error Amplifier, Q₇₀₀₈ and Q₇₀₀₉ (2SC945AQ), and back to Q₇₀₀₇.

Power Supply PS2 provides 8 V for memory backup through power transformer PT1 and bridge rectifier D₇₀₀₁ (S2VB10), delivering 12 V to the 13.5 V bus when the POWER Switch is off. This 12 V is regulated by Q₇₀₀₄ (2SC2562Y) and Q₇₀₀₅ (2SC945AQ) to provide PS2 plus 8 V.

PLL CIRCUITS

The PLL system is composed of four loops, each consisting of a VCO, prescaler, crystal oscillator reference signal, programmable divider and a phase detector. Synthesized signal frequencies are thus produced for the local signals for transmitter and receiver stages, using 10 Hz steps. In PLL4, the VCO to be used is selected by the microprocessor in the Control Unit, which chooses one of 6 VCOs, each covering a 5 MHz portion of the 30 MHz range of the First Local signal. PLL1 is located on the Local Unit, but is functionally an integral part of the rest of the PLL circuitry located on the PLL Unit.

PLL Circuit Configuration

The 73.115 MHz–102.11499 MHz First Local signal is generated by one of the six VCO's composed of Q₆₀₀₁–Q₆₀₀₆ (2SC1923-O) selected for the desired 5 MHz portion of the frequency range by the microprocessor on the Control Unit. This signal from the VCO is buffered by Q₆₀₀₈ (2SC1923-O) and Q₆₀₀₇ (2SC2026) before being

delivered to the RF Unit (PB-2256), where it is buffered further by Q₁₀₁₆ (2SC1923-O) and Q₁₀₁₇ (2SC2026), and amplified by Q₁₀₁₈ (2SC2407) and Q₁₀₁₉ (2SC1589) before being delivered to the mixer.

A portion of the signal from the selected VCO is also amplified by Q₆₀₀₉ (3SK74L) and fed to the mixer composed of Q₆₀₁₆ and Q₆₀₁₇ (2SK206-3), where it is mixed with the 105.115 MHz–106.11499 MHz signal from PLL3. The resulting 3 to 32 MHz output of the mixer is buffered by Q₆₀₁₈ (2SC1923-O), amplified by Q₆₀₁₉ (2SC2026), and buffered again by Q₆₀₂₀ (2SC1923-O) and Q₆₀₂₁ (2SC2407) before being applied to the Programmable Divider composed of Q₆₀₁₁ (SN74S113N), Q₆₀₁₂ (SN74S11N), Q₆₀₁₃ (SN74LS196N) and Q₆₀₁₅ (SN74LS196N); which is programmed by ROM Q₆₀₁₄ (TBP18SA030N-0376), fed with the 10 MHz and 1 MHz binary data from the Control Unit.

Thus the Programmable Divider feeds a 1 MHz signal to Phase Detector Q₆₀₂₂ (MC4044P), which also receives a 1 MHz reference from Reference Amplifier Q₆₀₂₆ (2SC945AQ). 20.0 MHz crystal reference oscillator Q₆₀₆₂ (2SC535B) feeds a portion of its signal through buffer Q₆₀₆₁ (IF-1033B) to 1/20 divider Q₆₀₆₀ (HD10551), a portion of whose output provides 1 MHz to Q₆₀₂₆.

The Error Correcting DC voltage from the Phase Detector is then fed through the low-pass filter composed of Q₆₀₂₃ through Q₆₀₂₅ (2SC732BL) before being applied back to the selected VCO, Q₆₀₀₁ to Q₆₀₀₆. Q₆₀₁₀ (2SD882Q) and Q₆₀₆₅ (2SC1959Y) each serve as Regulators to provide 5 V and 8 V respectively to the loop mentioned above (PLL4) from the 11 V supplied to the PLL Unit.

In PLL3, a 105 MHz signal is generated at VCO3, Q₆₀₂₉ (2SC1923-O), from where it is amplified by Q₆₀₂₈ (3SK74L) before being fed to the mixer in PLL4. A portion of the output of VCO3 is buffered by Q₆₀₂₇ (2SC945AQ) and applied to doubly balanced mixer Q₆₀₄₃ (SN76514N), which also receives a 48.615 MHz signal through buffer Q₆₀₄₂ (2SC945AQ) from crystal oscillator Q₆₀₄₁ (2SC535B). The 56.50 MHz–57.4999 MHz output of the mixer is then buffered by Q₆₀₃₉ (2SC945AQ) and applied to doubly balanced mixer Q₆₀₃₈ (SN16913P), which also receives a 56.280 MHz–57.27009 MHz signal from PLL2.

The 220.0 kHz–229.9 kHz output from this mixer is then buffered by Q₆₀₃₇ before being fed to the phase detector, Q₆₀₃₄ (MC4044P). This phase detector also receives a 220.0 kHz–229.9 kHz signal derived from the 22.0 MHz–22.99 MHz signal delivered to the PLL Unit from PLL1 on the Local Unit, after it is amplified by Q₆₀₃₂ (2SC1923-O) and divided by 100 at Q₆₀₃₃ (SN74LS390N). The DC output from the phase detector is fed to inverter Q₆₀₃₅ (SN74LS26N), which produces an Unlock signal if the PLL is not locked, and passes the Error Correcting Voltage to Switch Q₆₀₃₆ (MC14066B). This switch then passes the voltage on through a low-pass filter back to VCO3. 48.615 MHz crystal oscillator Q₆₀₄₁ has another output through buffer Q₆₀₄₄ (2SC945AQ) which is delivered to the Local Unit.

In PLL2, a 56.280 MHz–57.27009 MHz signal is generated at VCO2, Q₆₀₄₈ (2SC1923-O), from where it is buffered by Q₆₀₅₀ (2SC945AQ) before being fed to mixer Q₆₀₃₈ in PLL3. A portion of the output of VCO2 is buffered by Q₆₀₄₉ (2SK19TMGR) and applied to doubly balanced mixer Q₆₀₅₃ (SN16913P), which is also fed with a 54.280 MHz–54.28009 MHz signal from VCXO Q₆₀₅₁ (2SC535B), buffered by Q₆₀₅₂ (2SC945AQ). The VCXO frequency is controlled by the 10 Hz BCD

Data from the Control Unit, through Digital-to-Frequency Converter D₆₀₂₈ (1T25).

The 2.0 MHz–2.99 MHz output of the mixer is amplified by Q₆₀₅₄ (2SC945AQ) and fed to programmable divider/phase detector Q₆₀₅₅ (MB8718M), which also receives a 10 kHz reference signal derived from the 20.0 MHz Reference Oscillator Q₆₀₆₂, through Q₆₀₆₁ and 1/20 Divider Q₆₀₆₀ mentioned as the 1 MHz reference in PLL4, which is further divided by 100 at Q₆₀₅₉ (MC14518B) to provide this 10 kHz reference and also the 10 kHz reference for PLL1 on the Local Unit. Q₆₀₅₅ also receives the 100 kHz and 10 kHz BCD Data delivered from the Control Unit. A PLL Unlock signal from Q₆₀₅₅ connects with the Unlock signal from PLL3 and is delivered to the Control Unit. The DC Error Correcting Voltage from Q₆₀₅₅ is fed through low-pass filters Q₆₀₄₆ (2SC732TMBL) and Q₆₀₄₇ (MPS-A13) back to VCO2.

PLL1 is located on the Local Unit (PB-2253). Its 22.0 MHz–22.99 MHz output is generated at VCO1, Q₃₀₃₄ (JF1033B), and then buffered by Q₃₀₃₅ (2SK19TMGR) before being delivered to amplifier Q₆₀₃₂ (mentioned in PLL3) on the PLL Unit. A portion of the output of VCO1 is buffered by Q₃₀₃₃ (2SK19TMGR) on the Local Unit and applied to doubly balanced mixer Q₃₀₃₂ (SN-16913P), which also receives a 20.0 MHz signal from 20.0 MHz Reference Oscillator Q₆₀₆₂, buffered by Q₆₀₆₃ (JF1033B) before being delivered from the PLL Unit.

The 2.0 MHz–2.99 MHz output from the mixer is amplified by Q₃₀₃₁ (2SC945AP) and applied to programmable divider/phase detector Q₃₀₃₀ (MB-8718M), which also receives a 10 kHz reference signal through Reference Amplifier Q₃₀₂₇ (2SC-

945AP) after being delivered from 1/100 Divider Q₆₀₅₉ on the PLL Unit. Q₃₀₃₀ also receives 1 kHz and 100 Hz data delivered from the Control Unit, while the Unlock signal from Q₃₀₃₀ is delivered to the Control Unit together with the Unlock signals from PLL3 and PLL2 on the PLL Unit. The DC Error Correcting Voltage from Q₃₀₃₀ is fed through a low-pass filter composed of Q₃₀₂₈ and Q₃₀₂₉ (2SC732TMBL) before being fed back to VCO1. Q₃₀₂₆ (2SC945AP) is used as an 8 V regulator to provide DC for PLL1 on the Local Unit from 13.5 V.

On the PLL Unit, Q₆₀₅₇ (2SC945AQ) and Q₆₀₅₈ (2SC1959Y) act as 5 V regulators from the 11 V supply bus; while Q₆₀₄₀, Q₆₀₄₅ (2SC1959Y) and Q₆₀₃₀ and Q₆₀₆₄ (2SC945AQ) act as 8 V regulators from the 11 V.

PLL CIRCUIT FREQUENCY RELATIONSHIPS

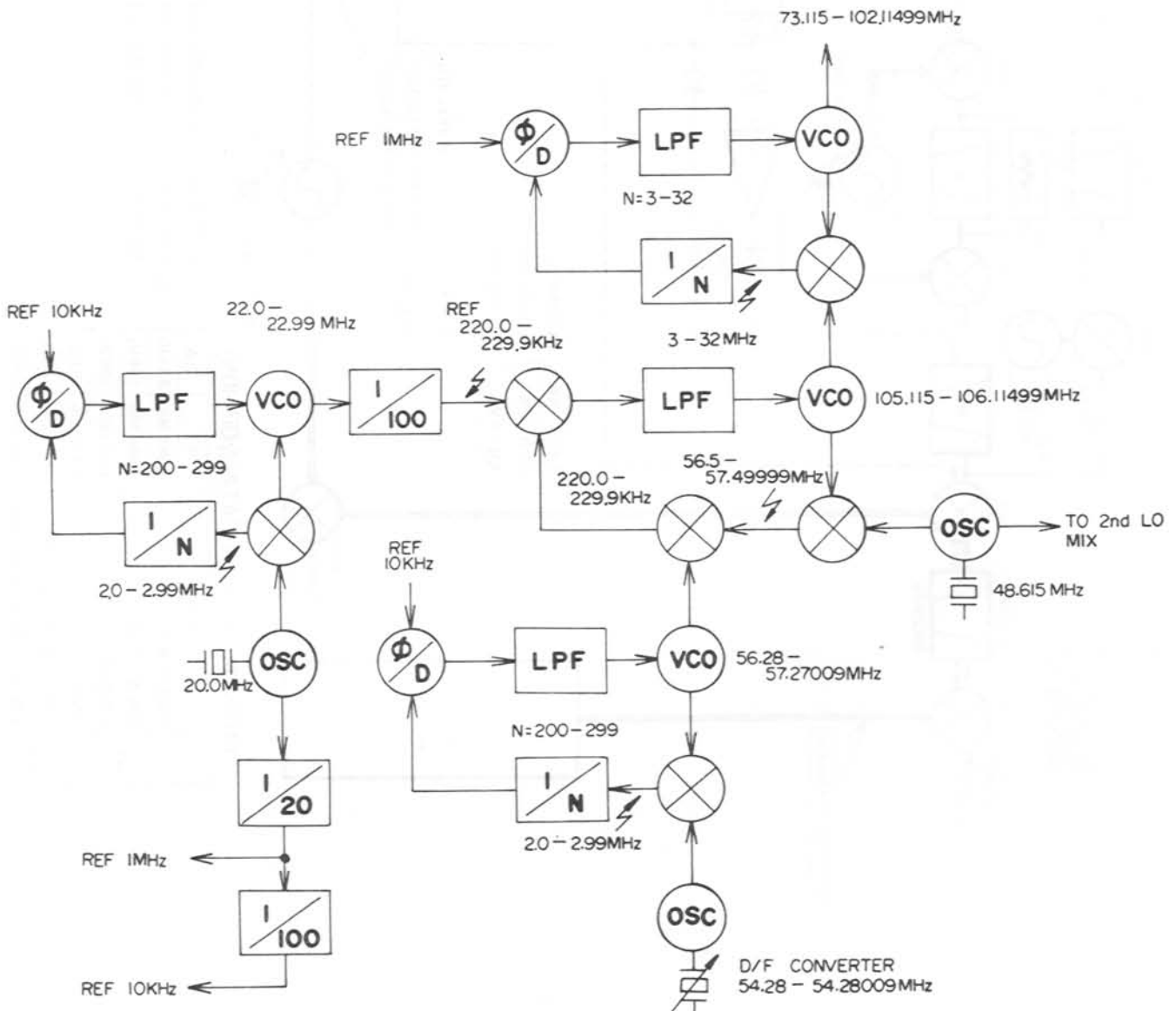

FREQUENCY RANGE MODIFICATION

The following information will allow you to change the transmitting and receiving frequencies of the FT-ONE to conform with local requirements.

1. Remove the CONTROL UNIT from the FT-ONE.
2. Referring to Figures 1 and 2 (following page), note that connecting a jumper wire from Point A to either Point B or C sets the receiving frequency range; while connecting another jumper wire from Point D to Point E, F, G or H sets the transmitting frequency range.
3. Solder the jumper wires to the appropriate points, selected from the Table below.
4. The example shown in Figure 3 illustrates how to set the receiver coverage for 150 kHz through 29.9999 MHz and the transmitter coverage for the new WARC bands.

RECEIVING FREQUENCY RANGE SETTING CHART

Range:	Jumper Connection:
150 kHz – 27 MHz, 28 MHz – 30 MHz (no 11 meter band)	A – C
150 kHz – 30 MHz	A – B

TRANSMITTING FREQUENCY RANGE SETTING CHART

Range:	Jumper Connection:
1.8 – 2 MHz; 3 – 4 MHz; 7 – 8 MHz; 10 – 11 MHz; 14 – 15 MHz; 18 – 19 MHz; 21 – 22 MHz; 24 – 25 MHz; 27 – 30 MHz (WARC plus 11 meter band)	D – E
1.8 – 2 MHz; 3 – 4 MHz; 7 – 8 MHz; 10 – 11 MHz; 14 – 15 MHz; 18 – 19 MHz; 21 – 22 MHz; 24 – 25 MHz; 28 – 30 MHz; (WARC)	D – F
1.8 – 2 MHz; 3 – 4 MHz; 7 – 8 MHz; 14 – 15 MHz; 21 – 22 MHz; 27 – 30 MHz (11 meters, no WARC)	D – G
1.8 – 2 MHz; 3 – 4 MHz; 7 – 8 MHz; 14 – 15 MHz; 21 – 22 MHz; 28 – 30 MHz (no 11 meters, no WARC)	D – H
1.8 – 30 MHz	No connection

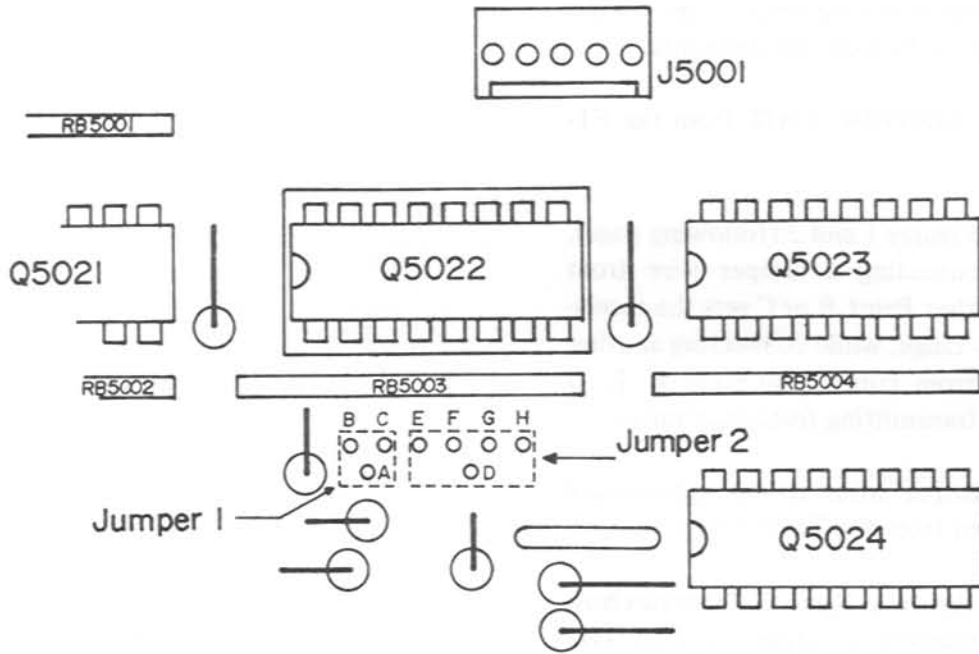

Figure 1

Viewed from components side

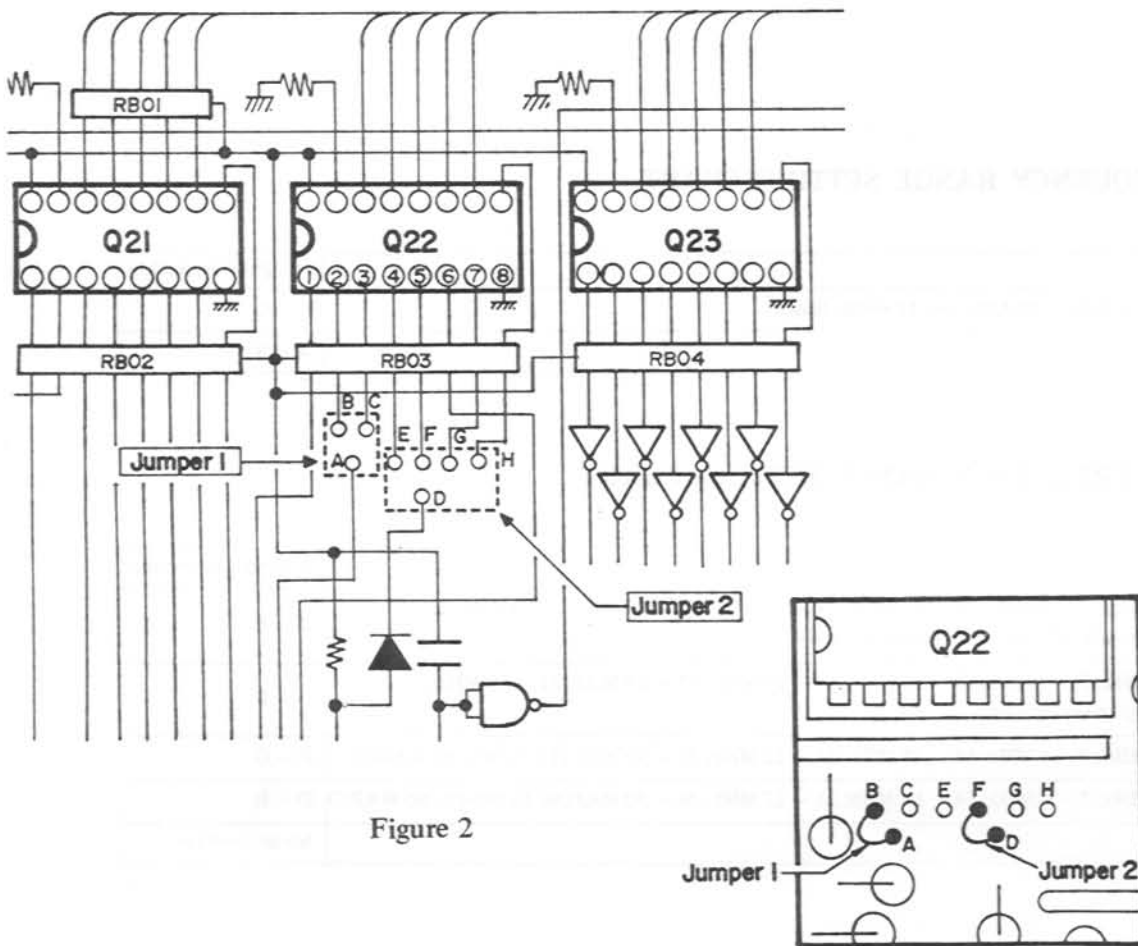

Figure 2

Receive : General coverage (Jumper 1 : A - B)
 Transmit: WARC (Jumper 2 : D - F)

Figure 3

QSK Operation Using the FT-ONE and a Full Break-in Linear Amplifier

To guard against accidental damage to non-QSK amplifiers, the FT-ONE is wired at the factory with the FLN-1 and FLN-2 lines (pins 6 and 7 on the ACC-1 jack) jumpered together. Therefore, to operate a QSK amplifier with the FT-ONE it is necessary to cut this jumper, located on the EXT

Cont Unit, PB-2338, PB-2367 or PB-2367A. This Unit is attached to the bottom of the chassis just beneath the LPF Unit, and is accessible by removing the bottom cover. (On some Units there is no silk screening on the circuit board). The location of the jumper to be cut is illustrated in the Figure.

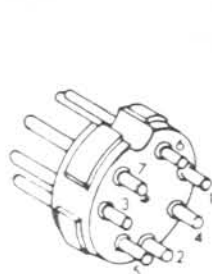

PIN No.	
1.	ALC
2.	RY COM.
3.	RY N.O. (Normally open)
4.	LNR GND (*1)
5.	RY N.C. (Normally closed)
6.	FLN-1
7.	FLN-2
Shell	GND

ACC-1

- *1. Connect to ground, except when using full break-in linear amplifier such as ALPHA 78.
- *2. Normally jumpered internally.
- *3. Remove internal jumper and connect to linear only when using a full break-in linear amplifier.

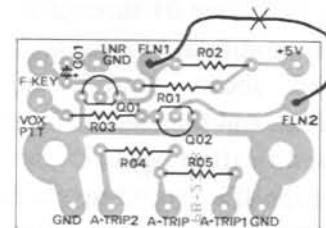

PB-2338

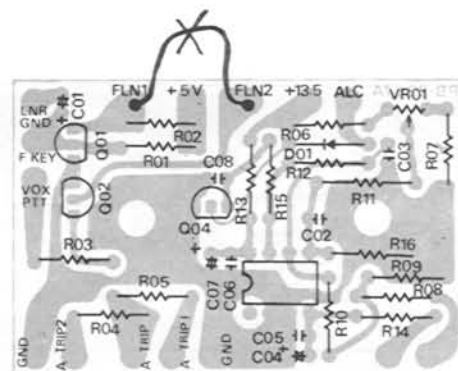

PB-2367/A

Connect the ACC-1 and ANT jacks on the FT-ONE to the jacks on the ALPHA 78 as shown in the diagram.

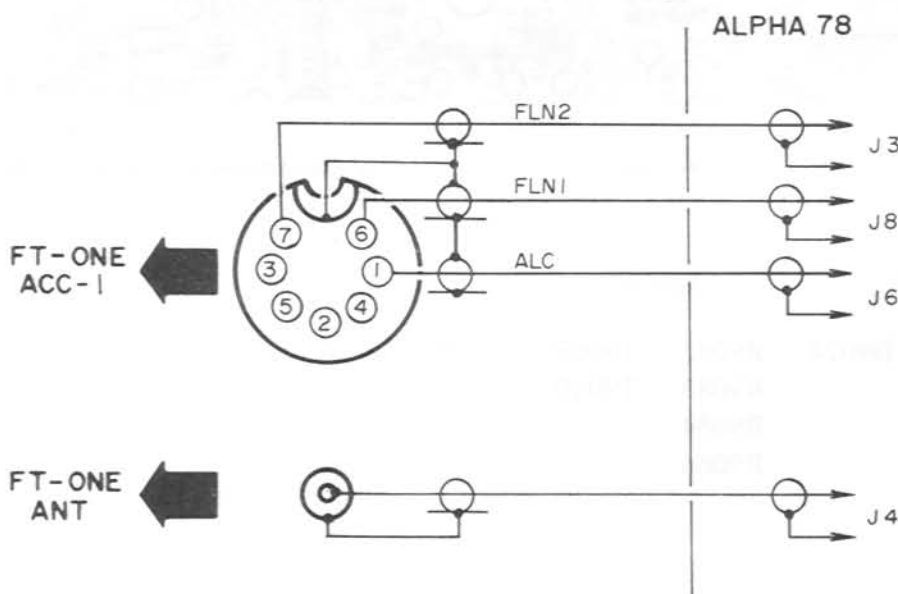

FT-ONE RECEIVER STABILITY IMPROVEMENT MODIFICATIONS

If your FT-ONE has a serial no. beginning with 01 or 02, you must ensure that a TX carrier oscillator sub-board is attached to the Local Unit before making the following modifications. If the sub-board is not attached and your dealer has not already contacted you, please contact the firm from whom you purchased your FT-ONE immediately.

The following modifications can improve receiver stability in many FT-ONES having serial nos. beginning with 01 through 03, and some beginning with 04 and 05. Some 01 through 05 lot units have already been modified, as have all units with serial nos. 06 and above. Modification A must be performed first, and then Modification B, if needed. If either modification appears too difficult after reading through the procedure (before beginning), contact your dealer for assistance.

A. Width Oscillator Modification

1. Remove the IF Unit (PB-2255 or PB-2255A) and locate the Width Oscillator Circuit enclosed with a metal shield. Referring to the figure below, locate transformer T₁₀. If this is the only transformer in the Width Oscillator enclosure, Modification A has already been performed.
2. Remove the shield on the solder side of the board, and then remove those components noted on the following figure.

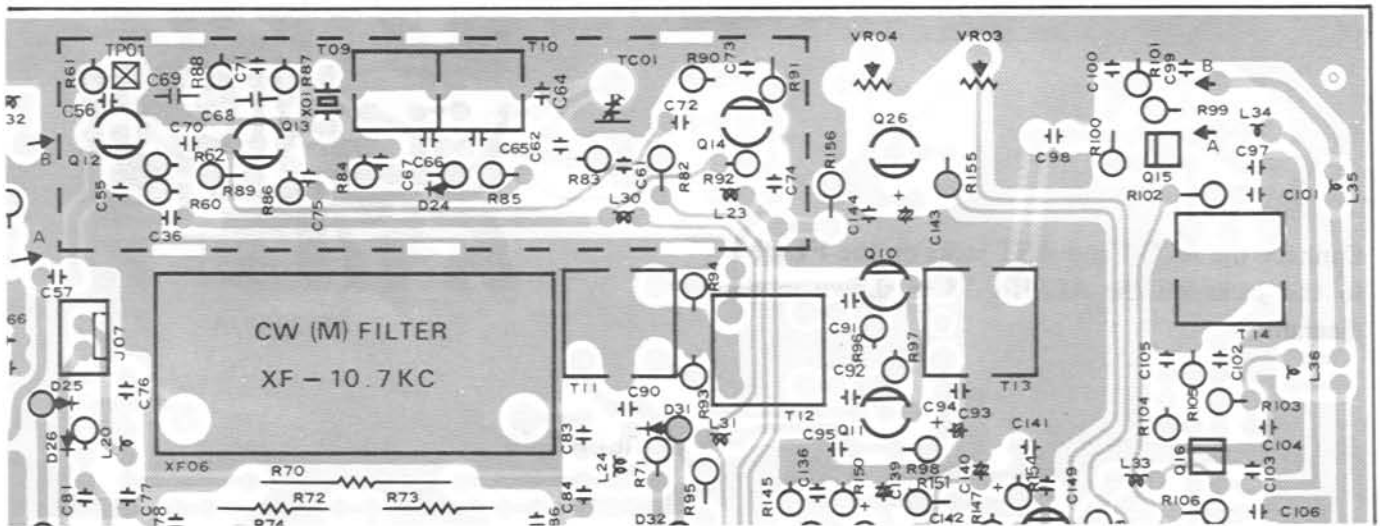

IF unit

Viewed from component side

Remove

- | | | | | | |
|-------|-------|-------|-------|--------|-------|
| C9062 | D9024 | R9082 | T9009 | TC9001 | X9001 |
| C9064 | | R9083 | T9010 | | |
| C9065 | | R9084 | | | |
| C9066 | | R9086 | | | |
| C9067 | | | | | |
| C9068 | | | | | |
| C9069 | | | | | |

3. Install the following parts on the board according to the figure on the following page.

Circuit Designation	Type or Value	Part Number
D9055	FC-52M5 varactor	G2090165
X9001	19.7475 MHz xtal	H0102470
R9085	10K ohm resistor	J02245103
R9086	12K ohm resistor	J02245123
R9214	10K ohm resistor	J01245103
R9215	22K ohm resistor	J10246223
C9068	47 pF CH cap	K02175470
C9069	100 pF CH cap	K02175101
C9201	62 pF UJ cap	K06179010
TC9001	40 pF trimmer	K91000096
L9060	FL5H151K	L1190020
T9010	transformer	L0021267

4. Remove the Local Unit (PB-2253/PB-2253A), and remove the shield covers from each side. Locate R₃₀₉₀ and R₃₀₉₁, and replace each of these resistors with 560K ohm resistors (part no. J02245564) as shown below.

5. Replace the shields on the Local Unit and the IF Unit, and reinstall these boards in the FT-ONE. Align the new Width Oscillator as follows:
 - a. Set the Width and Shift controls on the front panel to their center positions, and connect a frequency counter to TP₉₀₀₁ on the IF Unit.
 - b. Adjust TC₉₀₀₁ for a frequency of 19.7475 MHz on the counter. If TC₉₀₀₁ cannot tune this frequency, install a service extender board on the IF Unit and adjust T₉₀₁₀ for the correct frequency.

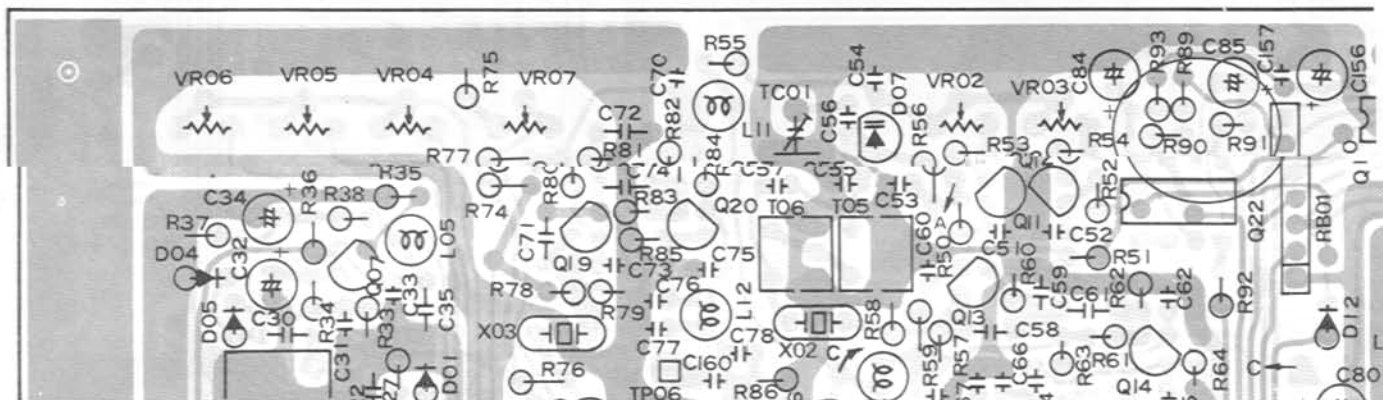

Viewed from component side

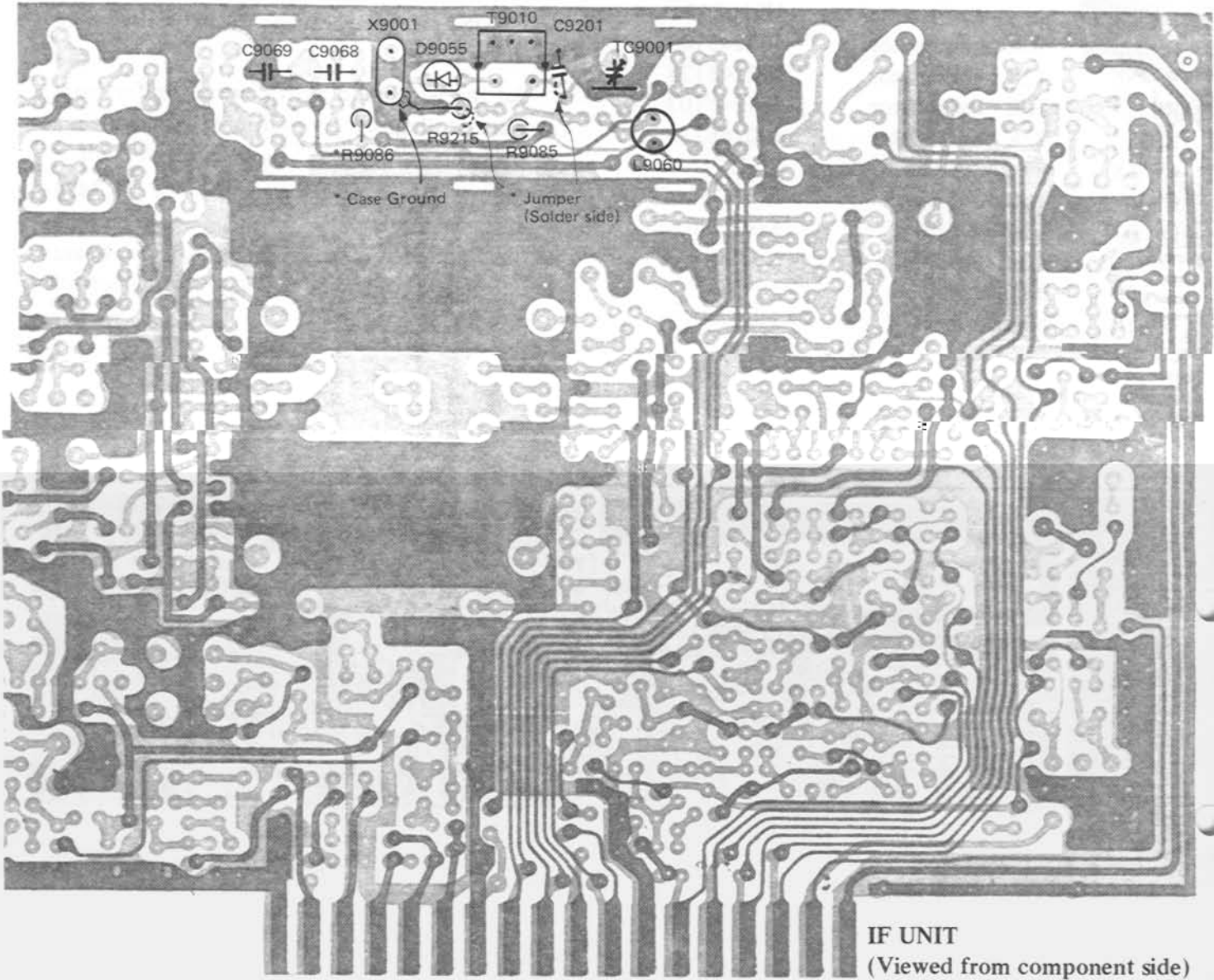
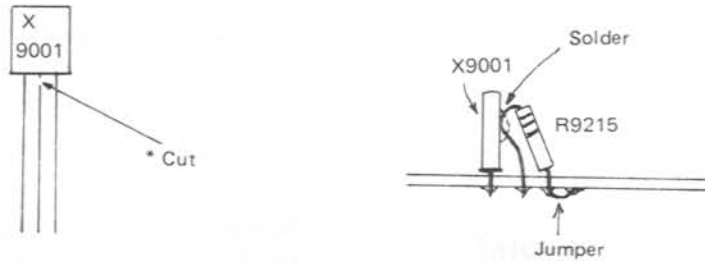

IF UNIT
(Viewed from component side)

Note:

* R₈₆ should be installed opposite to the printed indication on the board.
 Boldface wiring indicates interconnection with component lead.
 The lead of R₂₁₅ nearest X₀₁ should be soldered to the case of the crystal.
 The crystal has three leads, but the center lead is not used and should be cut.

Width Oscillator Schematic After Modification

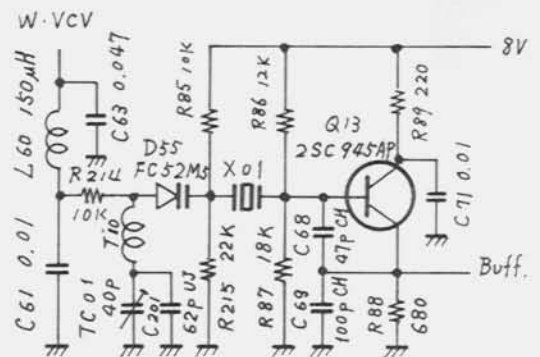

B. Shift Oscillator Modification

Modification A must be performed first.

1. Referring to the next two figures, remove the components from Local Unit PB-2253 or PB-2253A indicated. Note that the area

around C₅₇ differs on PB-2253 from PB-2253A. The modification, however, is the same.

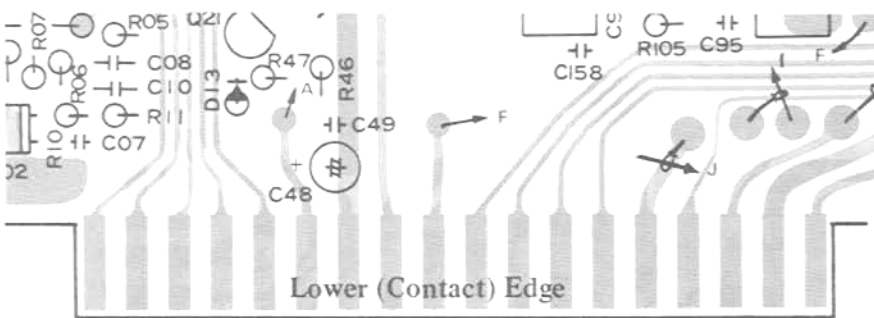
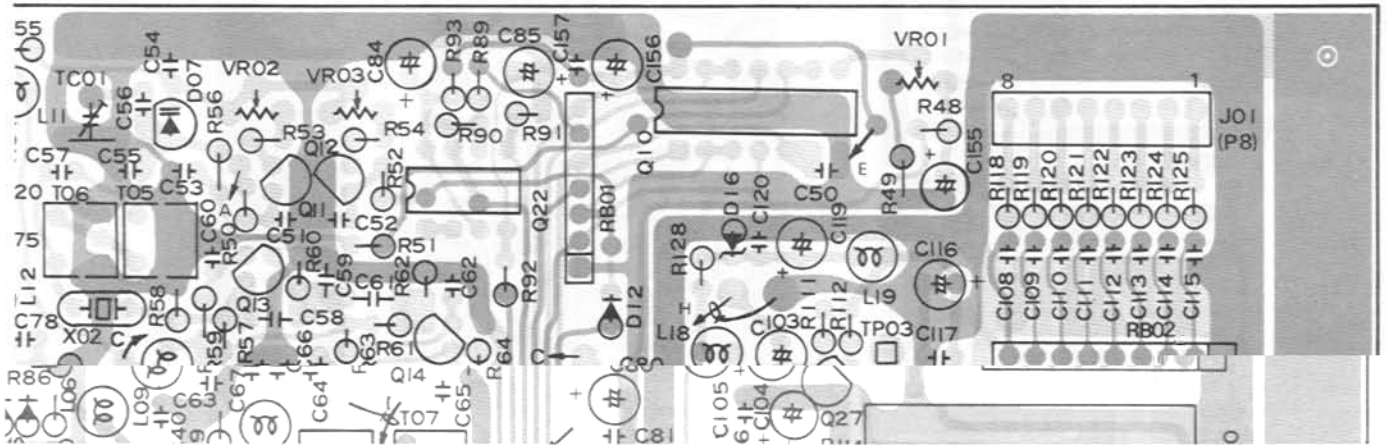

Remove

C3055	R3046	T3005
C3056	R3048	T3006
C3057	R3053	
C3058	R3055	TC3001
C3059	R3056	
C3061	R3057	VR3002
	R3059	
D3007	R3060	X3002

Circuit Designation	Type or Value	Part Number
D3024	FC52M5 varactor	G2090165
X3002	15.514 MHz xtal	H0102471
R3046	560 ohm resistor	J02245561
R3048	2.7K ohm resistor	J02245272
R3053	8.2K ohm resistor	J02245822
R3055	2.2K ohm resistor	J02245222
R3057	6.8K ohm resistor	J02245682
R3059	220 ohm resistor	J02245221
R3060	680 ohm resistor	J02245681
*R3090	270K ohm resistor	J02245274
*R3091	270K ohm resistor	J02245274
R3156	10K ohm resistor	J01245103
R3157	10K ohm resistor	J01245103
VR3002	20K ohm (B) pot.	J50749203
C3055	39 pF UJ cap.	K06175390
C3058	47 pF UJ cap.	K06175470
C3059	100 pF UJ cap.	K06175101
C3061	7 pF CH cap.	K02173070
C3164	47 pF CH cap.	K02175470
TC3001	40 pF trimmer	K91000096
T3005	transformer	L0021271

2. Install the following parts on the board according to the figures on the following page.

* These were changed once in Modification A, but must be changed again for Modification B.

3. Align according to the procedure on pages 3-12 and 3-13.

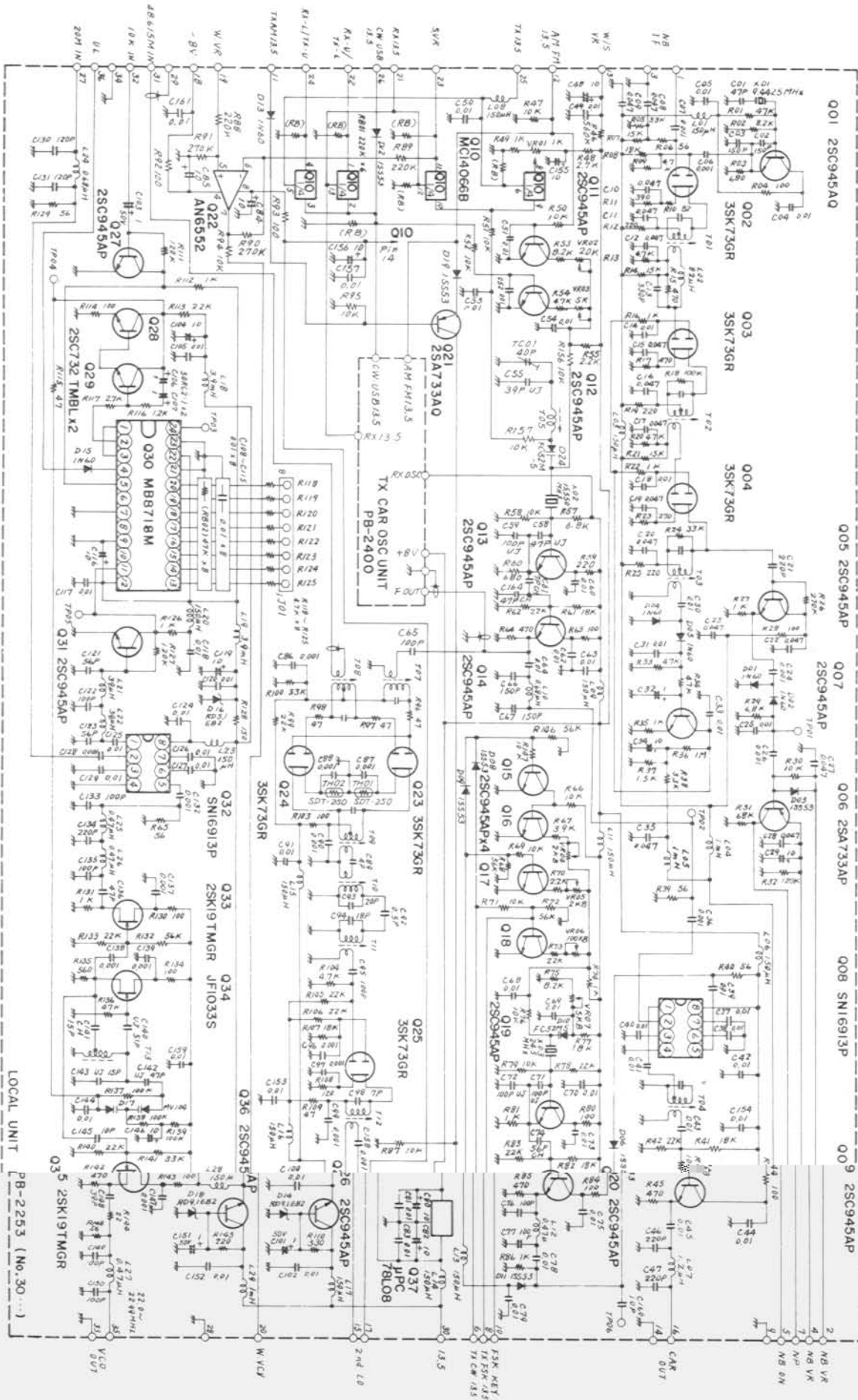

SECTION 3—SERVICING

OUTER COVER REMOVAL	3-1
BOARD LAYOUT	3-2
FRONT PANEL REMOVAL	3-3
REAR PANEL REMOVAL	3-4
ALIGNMENT	3-7
PARTS LAYOUT AND CIRCUIT DIAGRAM	3-23
RF UNIT (PB-2256)	3-23
SENSOR UNIT (PB-2265)	3-26
IF UNIT (PB-2255)	3-27
AF UNIT (PB-2252)	3-31
KEYER UNIT (PB-1728A)	3-34
LOCAL UNIT (PB-2253)/TX CAR OSC UNIT (PB-2400)	3-35
CONTROL UNIT (PB-2251)	3-39
RAM BOARD UNIT (PB-2267)	3-42
PLL UNIT (PB-2257)	3-43
100W PA UNIT (PB-2321)	3-48
DIODE SW UNIT (PB-2266)	3-51
ALC UNIT (PB-2260)	3-52
REG UNIT (PB-2258)	3-54
LPF UNIT (PB-2259)	3-58
PUSH SW UNIT (PB-2264)	3-60
LEVER SW UNIT (PB-2263)	3-61
KEYBOARD UNIT (PB-2262)	3-62
EXT CONTROL UNIT (PB-2367A)	3-63
DISPLAY UNIT (PB-2261)	3-64
FM UNIT (PB-2254)	3-66
SOLDERING AND DESOLDERING TECHNIQUE	3-70

OUTER COVER REMOVAL

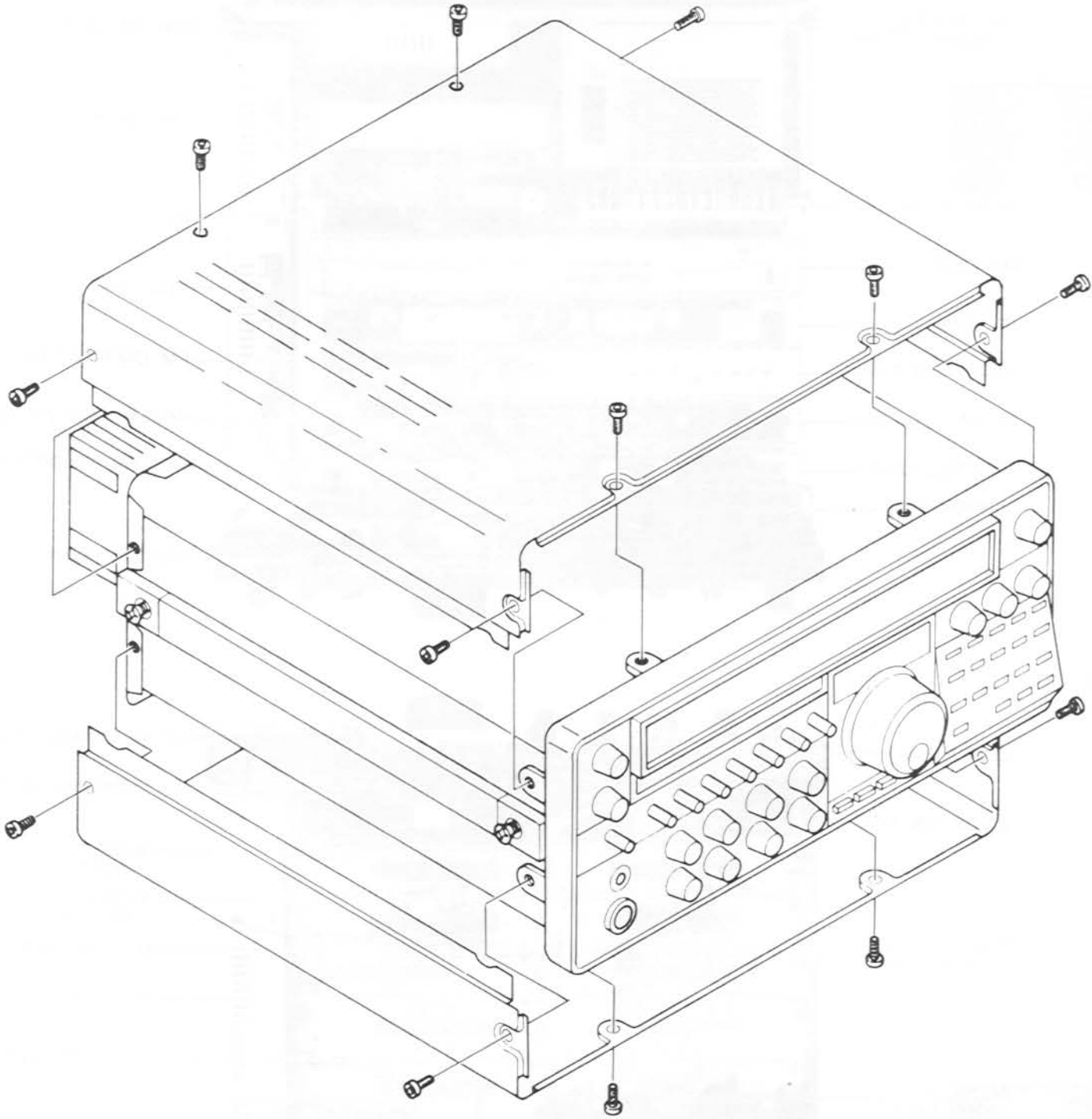

REMOVAL OF COVER

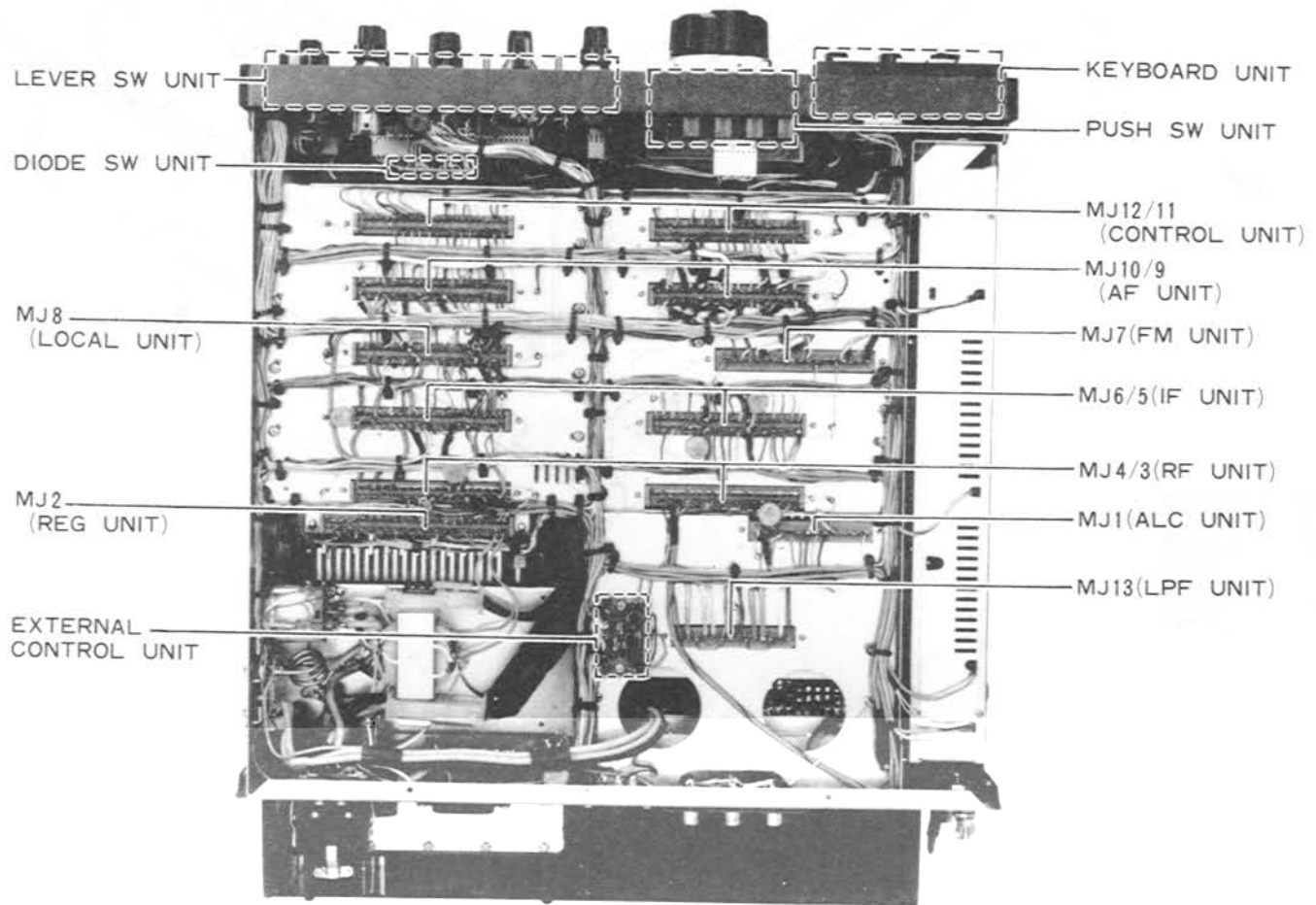
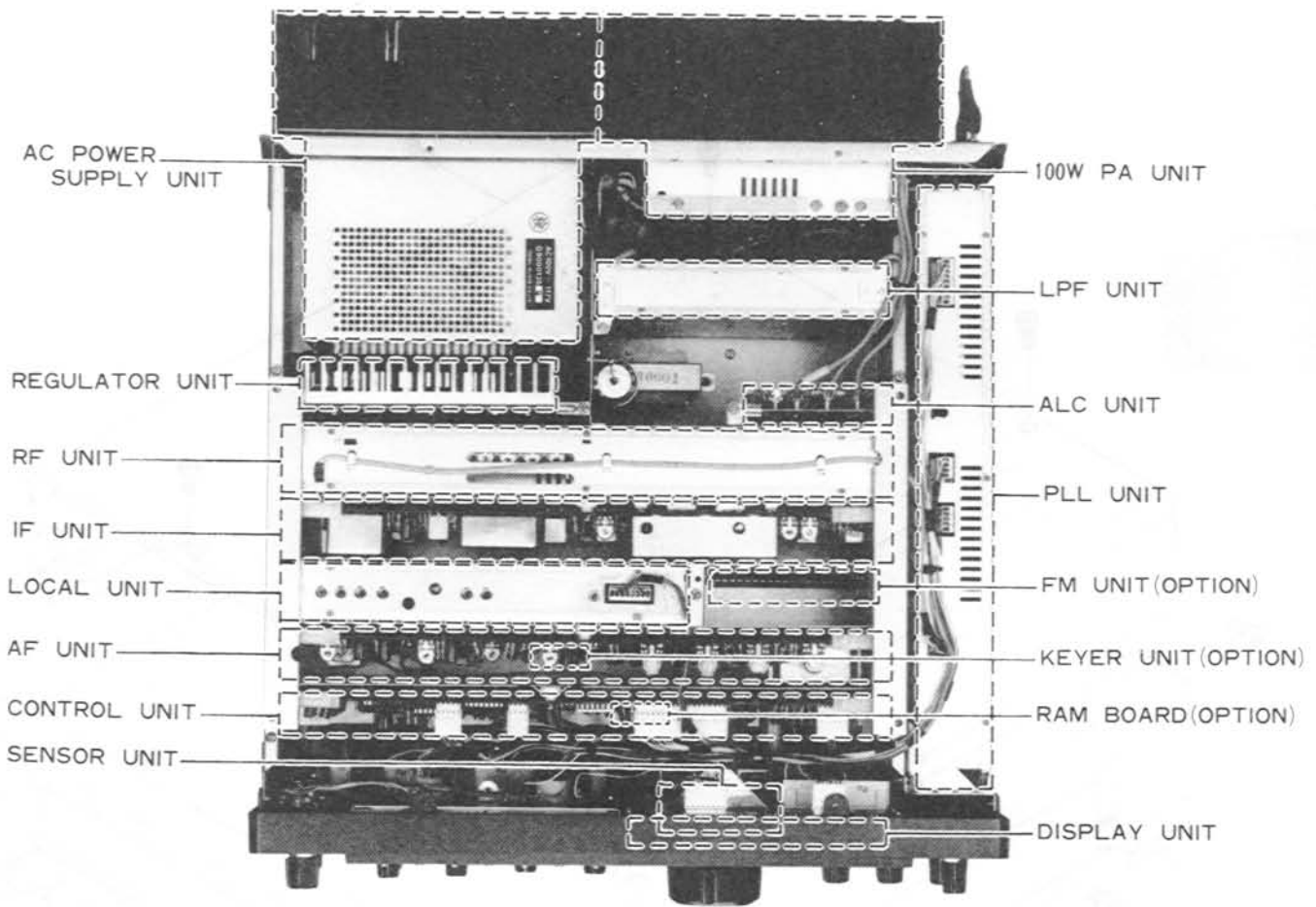

BOTTOM VIEW

FRONT PANEL

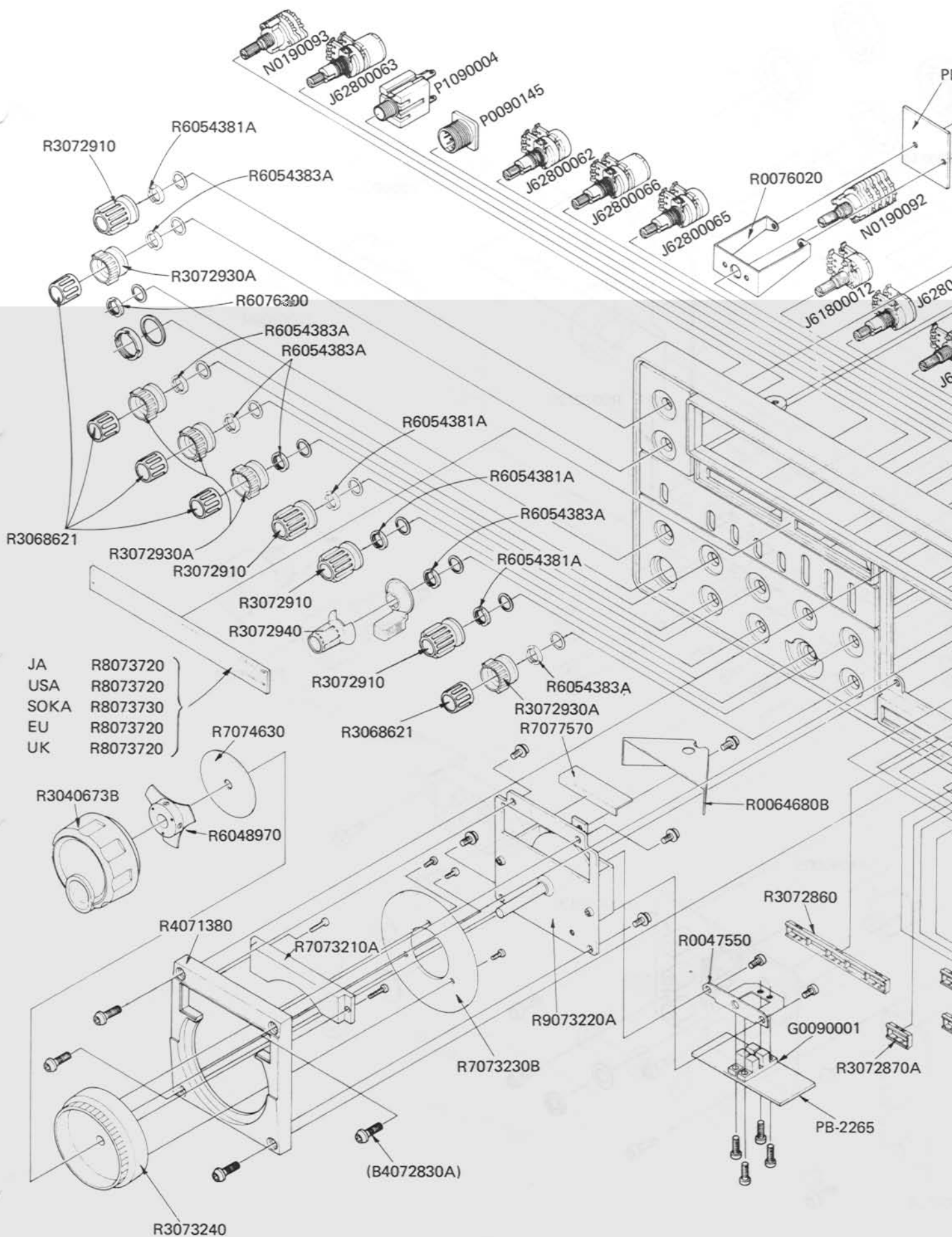

- | | |
|------|----------|
| JA | R8073720 |
| USA | R8073720 |
| SOKA | R8073730 |
| EU | R8073720 |
| UK | R8073720 |

REL REMOVAL

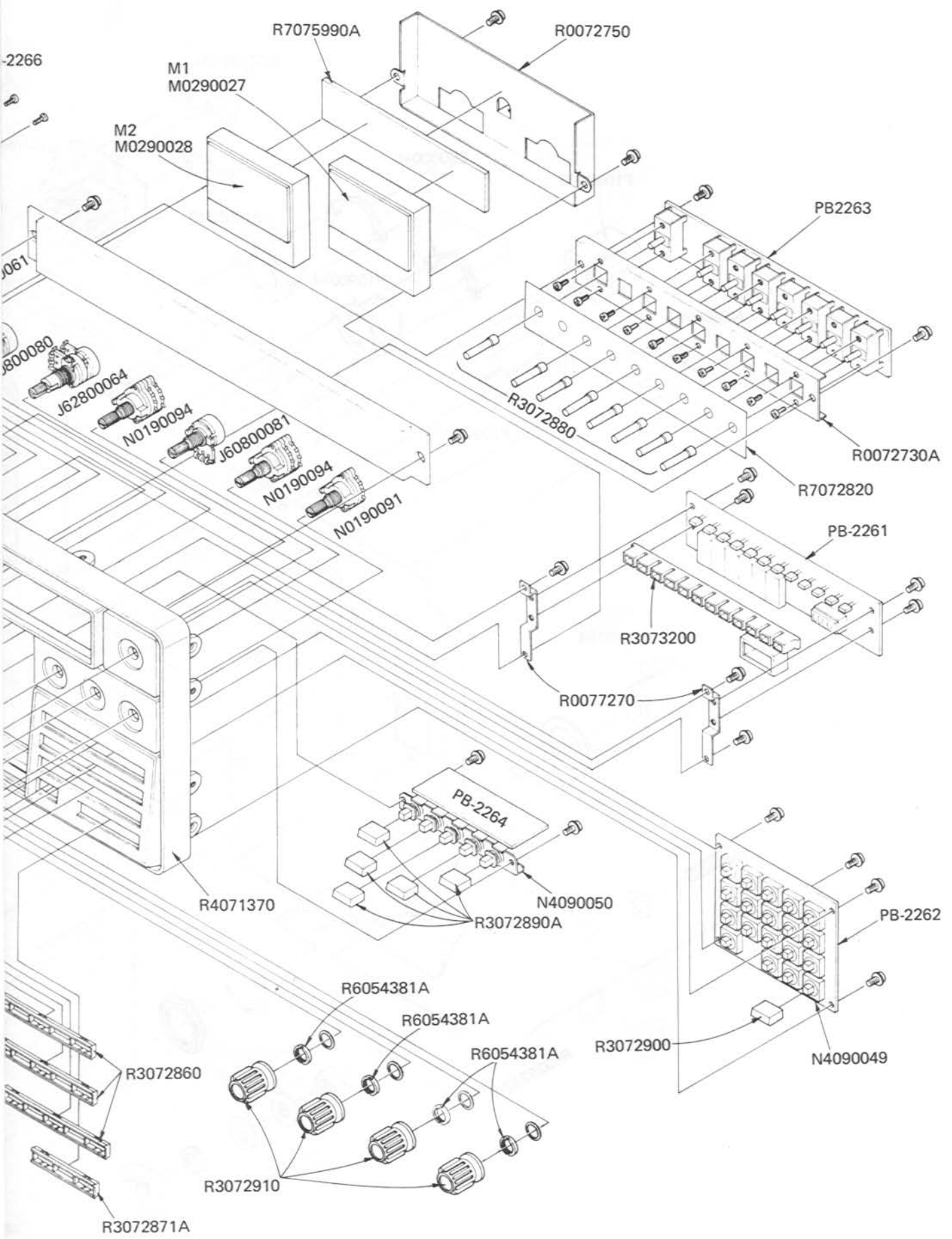

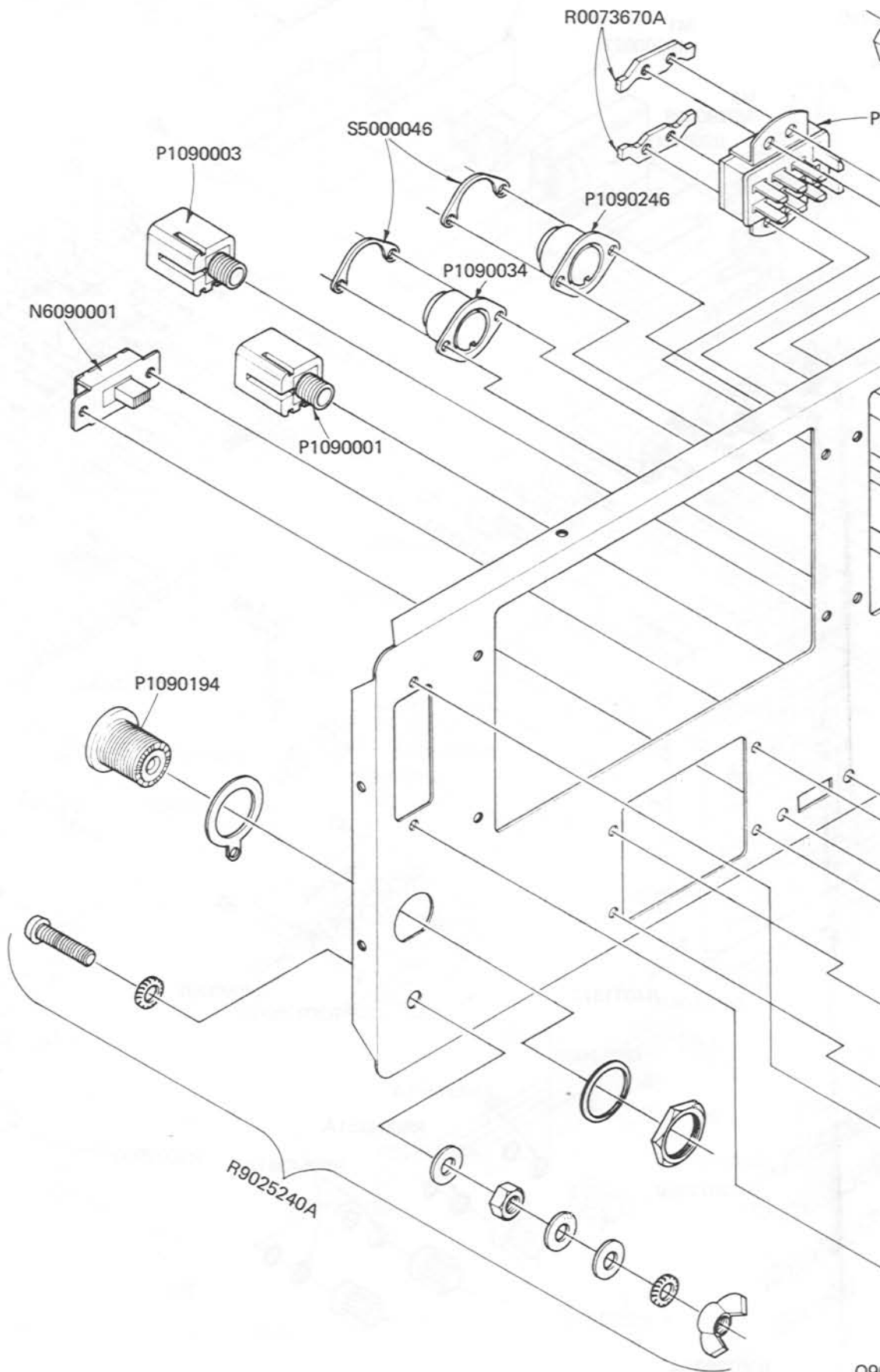

WHEEL REMOVAL (1)

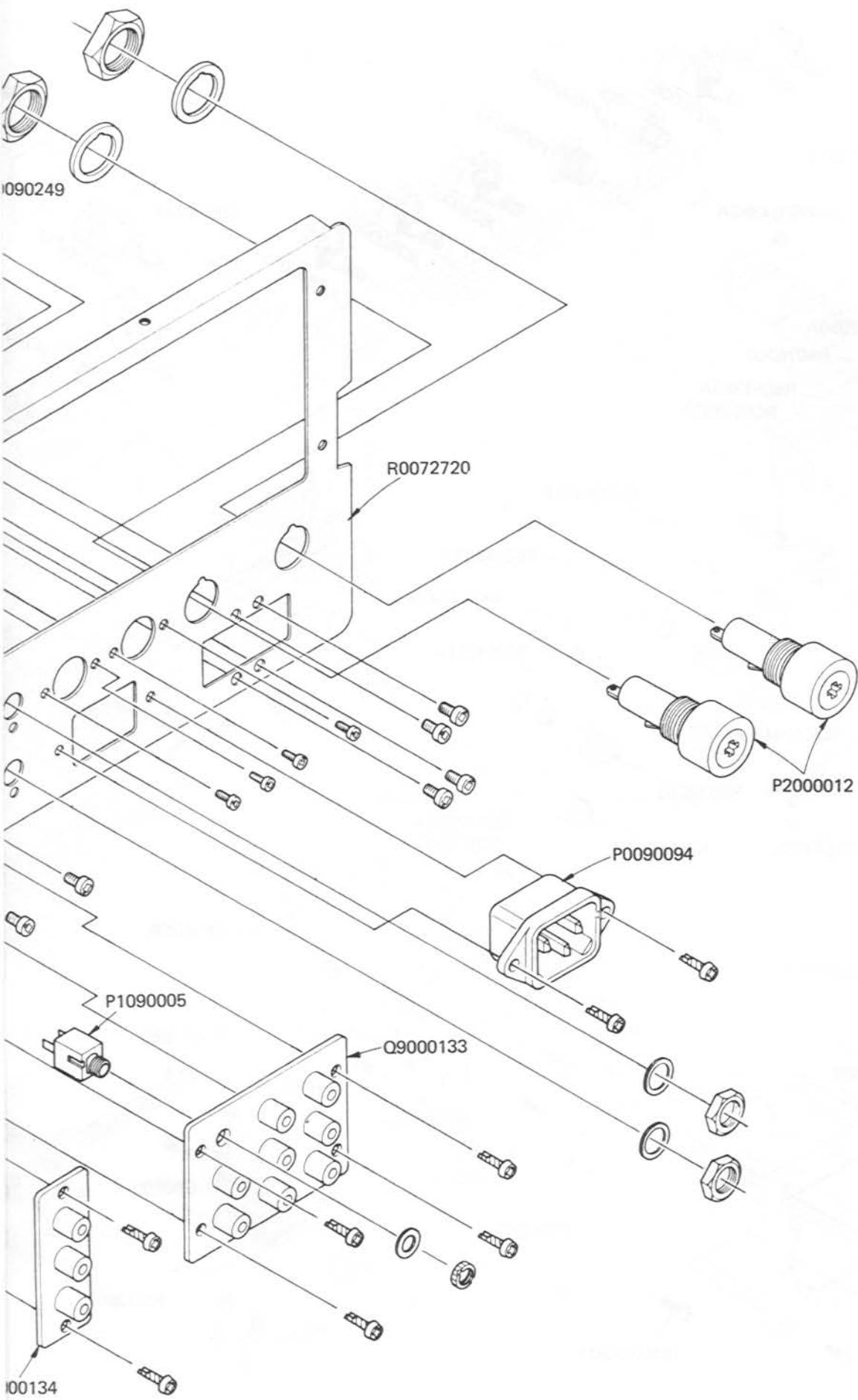

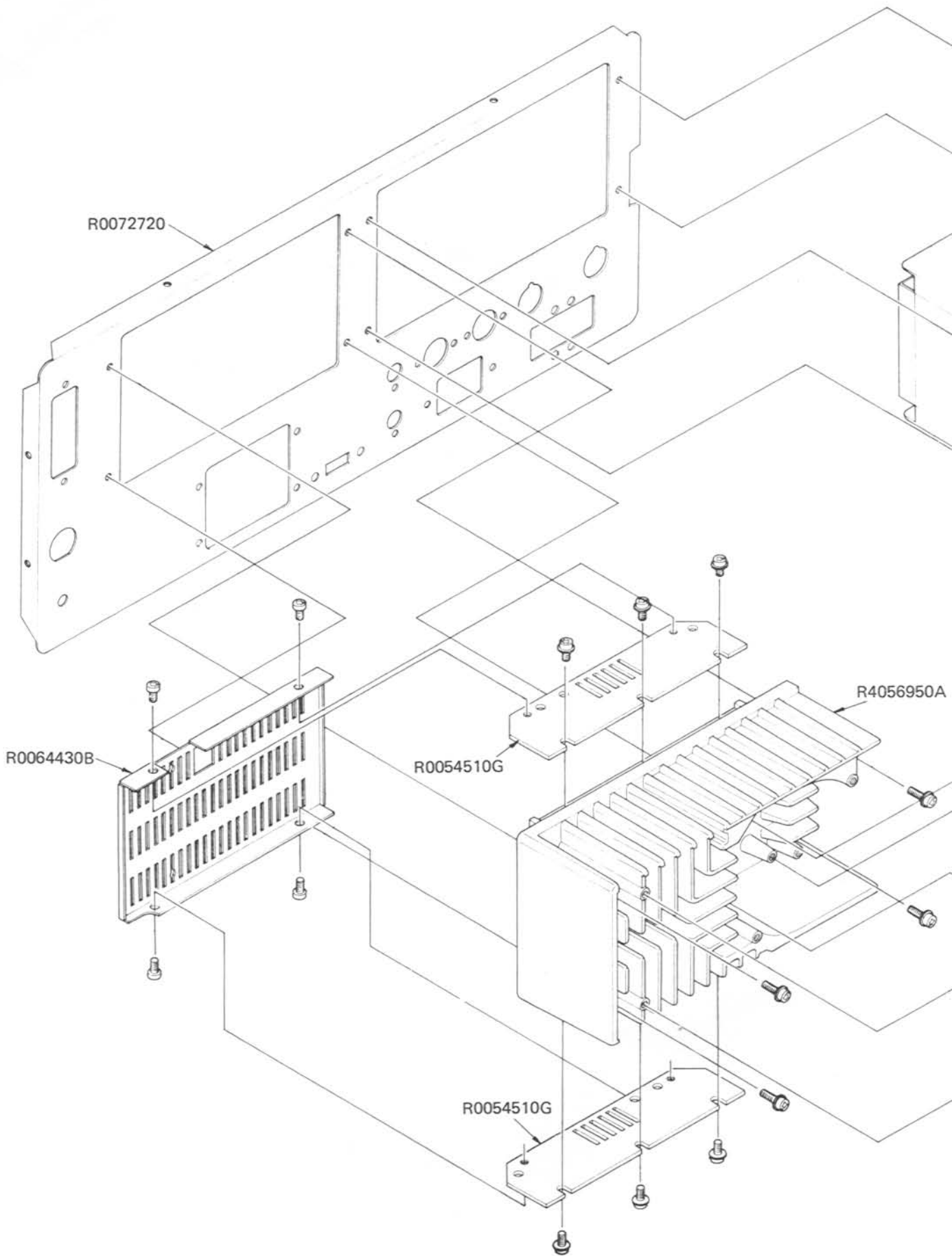

REMOVAL (2)

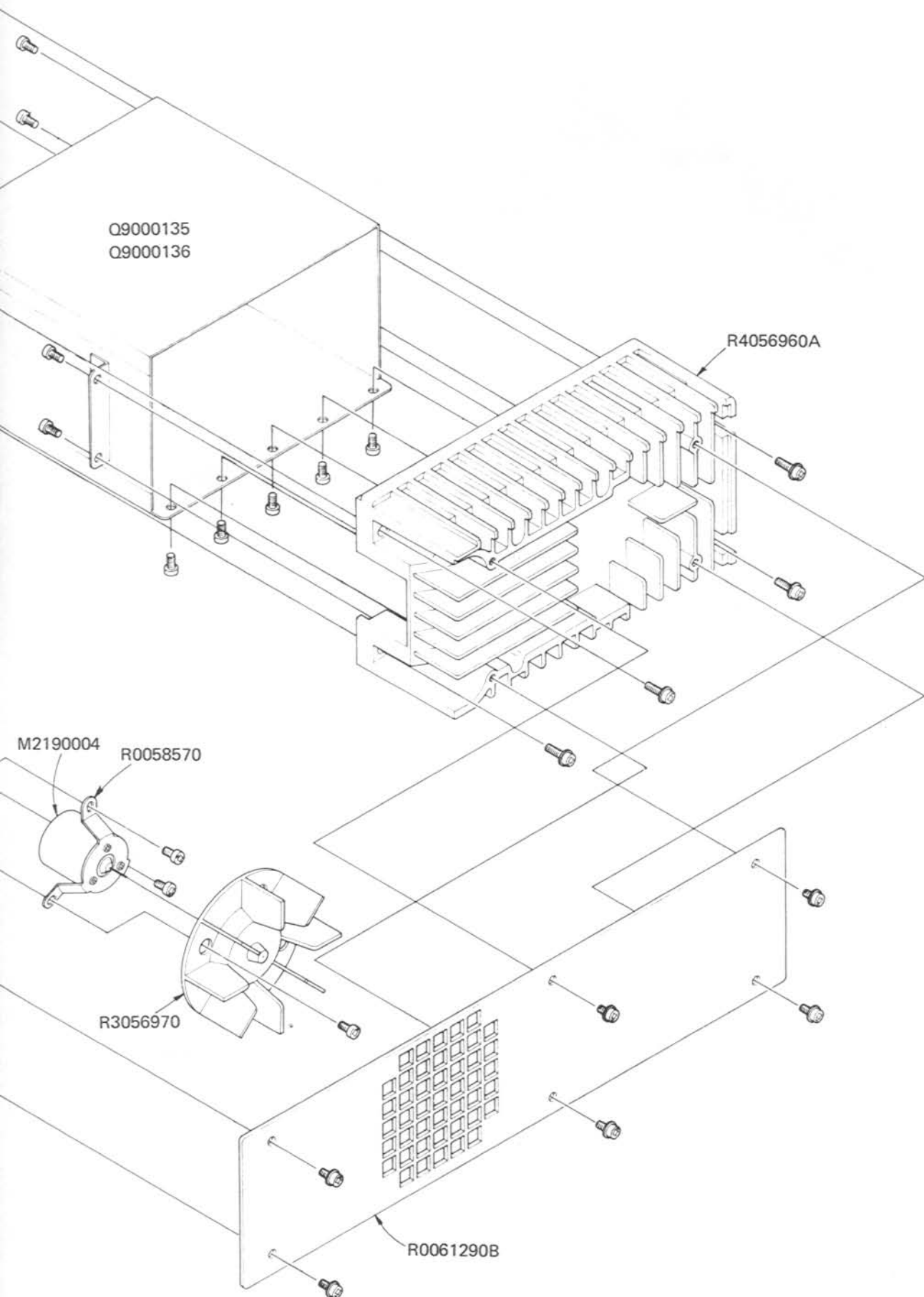

ALIGNMENT

The following Alignment Procedure for the FT-ONE is divided into two separate sections. The first section covers the various alignments and adjustments that may be made by the owner, as these do not require sophisticated test equipment outside of the FT-ONE itself and standard tools and equipment normally found in the ham shack. The second alignment section covers the sometimes critical and tedious adjustments, which must not be performed without the proper test equipment conforming to the specifications called for in the test equipment list. If you do not have, or are not familiar with this test equipment; or have any doubts about its use in these specific applications, you should not attempt any of the alignment procedures in this section. Unless you are experienced with alignment of these types of circuits and thoroughly understand their operation, let the alignments covered in the second section be performed by your authorized Yaesu dealer's service department.

Every FT-ONE has been completely aligned at the factory prior to shipment. However, your particular operating environment may call for some readjustments, such as VOX, Anti-trip, Monitor Volume, or Sidetone Pitch. Yaesu's design engineers have made a special effort to make these controls, and all of the adjustments that might require readjustment due to shipping and environmental variations, readily accessible to the user through the plastic circuit board cover under the cabinet's top cover. Under normal use, no other alignment should be necessary. Service or realignment of a major component may require substantial adjustment; under no circumstances, though, should realignment be attempted unless the operation of the transceiver is fully understood, the malfunction has been carefully analyzed, and the fault has definitely been traced to misalignment. Sudden difficulties are almost always caused by component failure rather than misalignment.

SECTION I

The following adjustments can be made by removing the top cover of the FT-ONE. The controls are labelled on the plastic cover over the pc boards, and can be adjusted with a small screwdriver. You will need to have on hand a microphone, CW key, headphones and, for the Carrier Balance adjustment, an external receiver in order to make these adjustments.

A. VOX Anti-Trip Level

1. Preset the transceiver front panel controls for normal SSB operation, but with the DRIVE control set to minimum. Tune in a station on the receiver, and set the AF GAIN for a comfortable listening level.
2. Preset the ANTI-TRIP control, VR₄₀₀₃, fully counter-clockwise (minimum). Place the microphone near to the loudspeaker (do not activate the PTT).
3. Rotate the VOX GAIN control on the front panel gradually clockwise from its counter-clockwise (minimum) position just to the point where the transmitter is activated.
4. Gradually rotate the ANTI-TRIP control, VR₄₀₀₃, clockwise to the point where the transmitter ceases to be activated by the audio from the loudspeaker.
5. Now retune the transceiver to a clear frequency and speak into the microphone to ensure that the VOX activates the transmitter properly.

B. AMGC (Automatic Mic Gain Control) Sensitivity

This control has been preset at the factory to cause the AMGC to pass on to the transmitter any signal presenting at least 1 mV (at 1 kHz) to the microphone jack. It may need to be readjusted to accommodate the particular microphone in use.

1. Preset the front panel controls for normal SSB transmission.
2. Close the PTT switch and speak into the microphone at normal volume, incorporating pauses in your speaking to allow the opportunity for the AMGC to trigger.
3. Adjust AMGC GAIN control VR₄₀₀₁ so that transmitter output appears on the meter when speaking.

C. AMGC Delay

This control is preset at the factory to allow a 1 second delay (pause) before squelching off the audio from the microphone to the transmitter.

1. Depress the PTT switch and speak into the microphone as above while adjusting the AMGC DELAY control, VR₄₀₀₂, for the desired delay after having stopped speaking, allowing a long pause.

D. CW Sidetone Pitch

1. Set the MODE selector on the front panel to one of the CW positions, and key down. Switch ON the MONI lever so that the sidetone is audible.
2. Adjust SIDETONE PITCH control VR₄₀₀₄ for the desired audio frequency. See page 26 of the Operating Manual for CW Spot calibration.

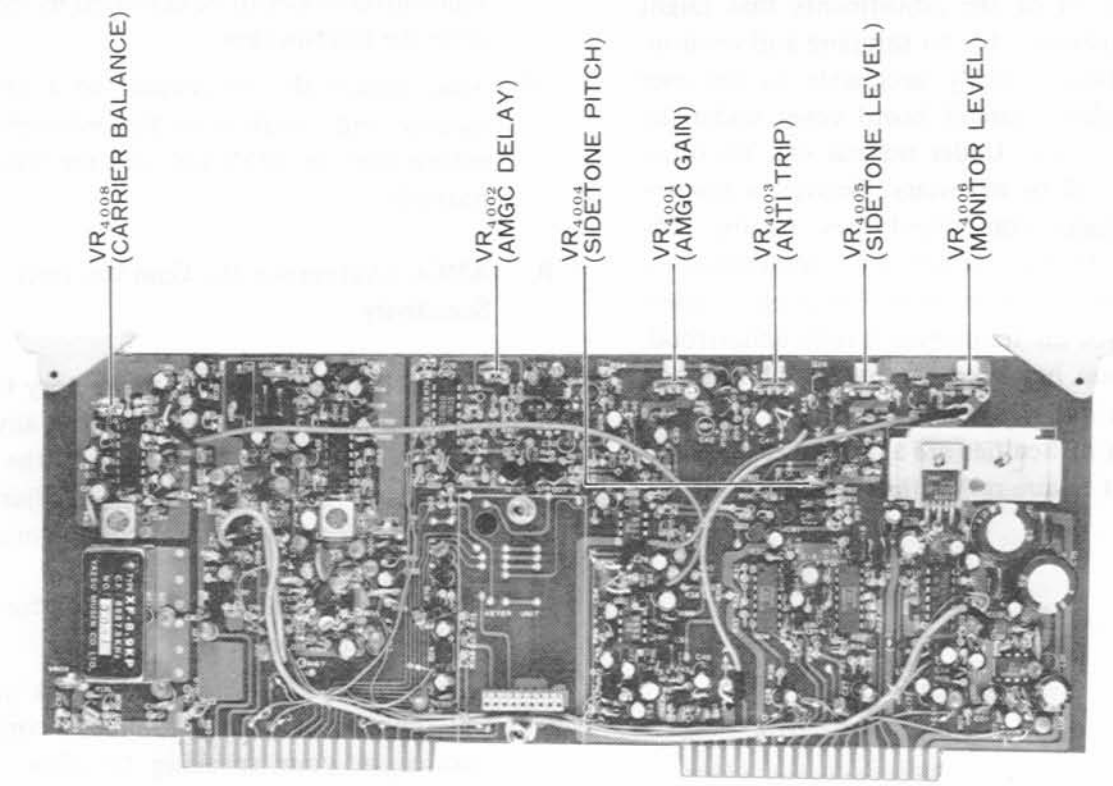
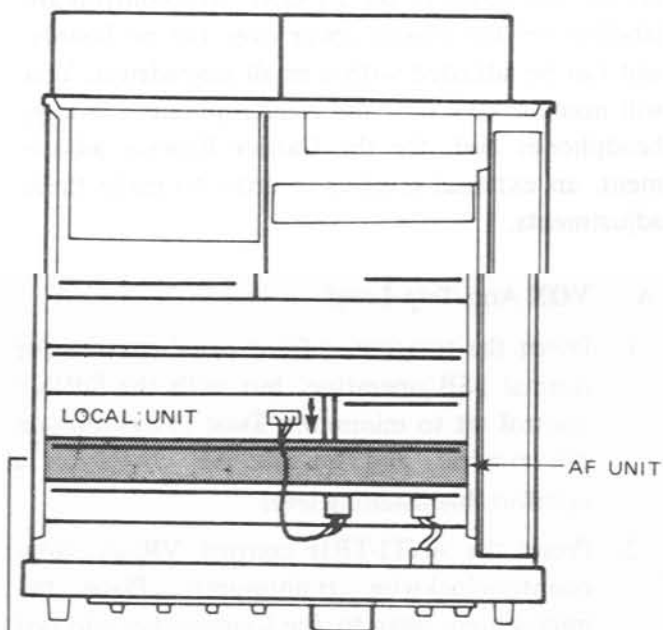

ALIGNMENT POINTS (SECTION I)

E. Sidetone Level

This control is preset at the factory to present a 60 mW signal to the speaker.

1. Using the same setup as in the previous adjustment, adjust LEVEL control VR₄₀₀₅ to your desired volume.

F. SSB Monitor Level

This control is preset at the factory so that, with the MIC GAIN control on the front panel set to maximum and a 0.5 mV, 1 kHz signal applied to the MIC jack, 60 mW of audio is presented to the speaker. For this adjustment, use headphones to monitor the transceiver so as to avoid feedback from the speaker to the microphone.

1. Set the MONI switch ON, and the MODE selector to LSB.
2. Depress the PTT switch and speak into the microphone while adjusting MONI LEVEL control VR₄₀₀₆ for a comfortable volume in the headphones.

G. Carrier Balance

1. Set the MODE selector to USB and tune the transceiver to the 14 MHz band.
2. Set the MIC GAIN control fully counter-clockwise (minimum), and disconnect the microphone from the MIC jack.
3. Set the VOX control fully counter-clockwise and into the click stop (MOX) position.
4. Tune an external receiver to the same frequency as the FT-ONE, and adjust CARRIER BALANCE control VR₄₀₀₈ for minimum signal at the external receiver.
5. Switch the MODE selector to LSB, and repeat step 4.
6. Switch back and forth from LSB to USB several times while adjusting VR₄₀₀₈ to obtain an equal minimum output in the two modes.

SECTION II

Those procedures marked with an asterisk (*) require the use of the optional Extender Board, which is available from Yaesu dealers.

SERVICE EXTENDER KIT

EXTENDER BOARD

14P	Single face	(D3100002)
18P	Double face	(D3100010)
22P	Double face	(D3100009)
18Px2	Double face	(D3100011)

EXTENDER CABLE (T9204357)

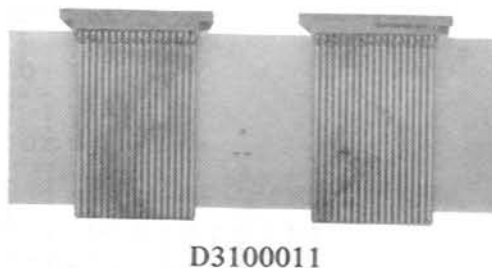
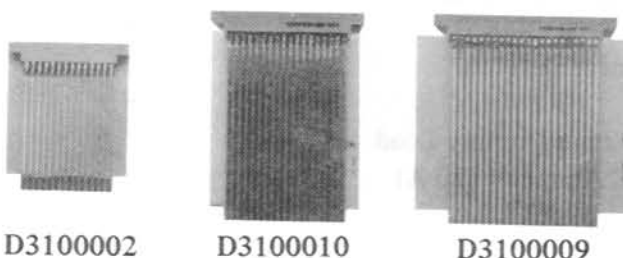

ALIGNMENT EQUIPMENT REQUIRED

The following precision test equipment is required for the alignment procedures in this section:

- Frequency Counter
YC-500E (YAESU) or equivalent
- Signal Generator
HP 8640B (Hewlett Packard) or equivalent
- DC Voltmeter
HP 4304B " "

VTVM with RF probe

HP 3406A (Hewlett Packard) or equivalent

AF VTVM

HP 400E

In-line Wattmeter

Bird 43

Dummy Load (200 W)

Bird 8343-200

Oscilloscope

HP 1222A (Hewlett Packard) or equivalent

Spectrum Analyzer

HP 141T

8552B

8553B

Distortion Meter

HP 334A

Audio Generator

HP 200CD

Linear Detector

HP 8901A

25 ohm Dummy Load

DC Ammeter (20 A)

COMMON CIRCUITS

PLL CIRCUIT

Set the FINE key OFF (out) to provide 100 Hz PLL steps.

(1) PLL Reference Oscillator (20 MHz)

- a) Connect the RF probe of the voltmeter and the frequency counter to pin 27 of edge connector MJ8.
- b) Adjust T_{6022} for a reading of 160 to 240 mV_{rms} on the meter.
- c) Adjust trimmer TC_{6003} for 20 MHz \pm 100 Hz on the counter.

(2) PLL Reference Oscillator (48.615 MHz)

- a) Connect the RF probe of the voltmeter and the frequency counter to pin 31 of edge connector MJ8.
- b) Adjust T_{6017} for maximum deflection on the meter (100 to 160 mV_{rms}).
- c) Adjust trimmer TC_{6001} for 48.615 MHz \pm 0.5 kHz on the frequency counter.

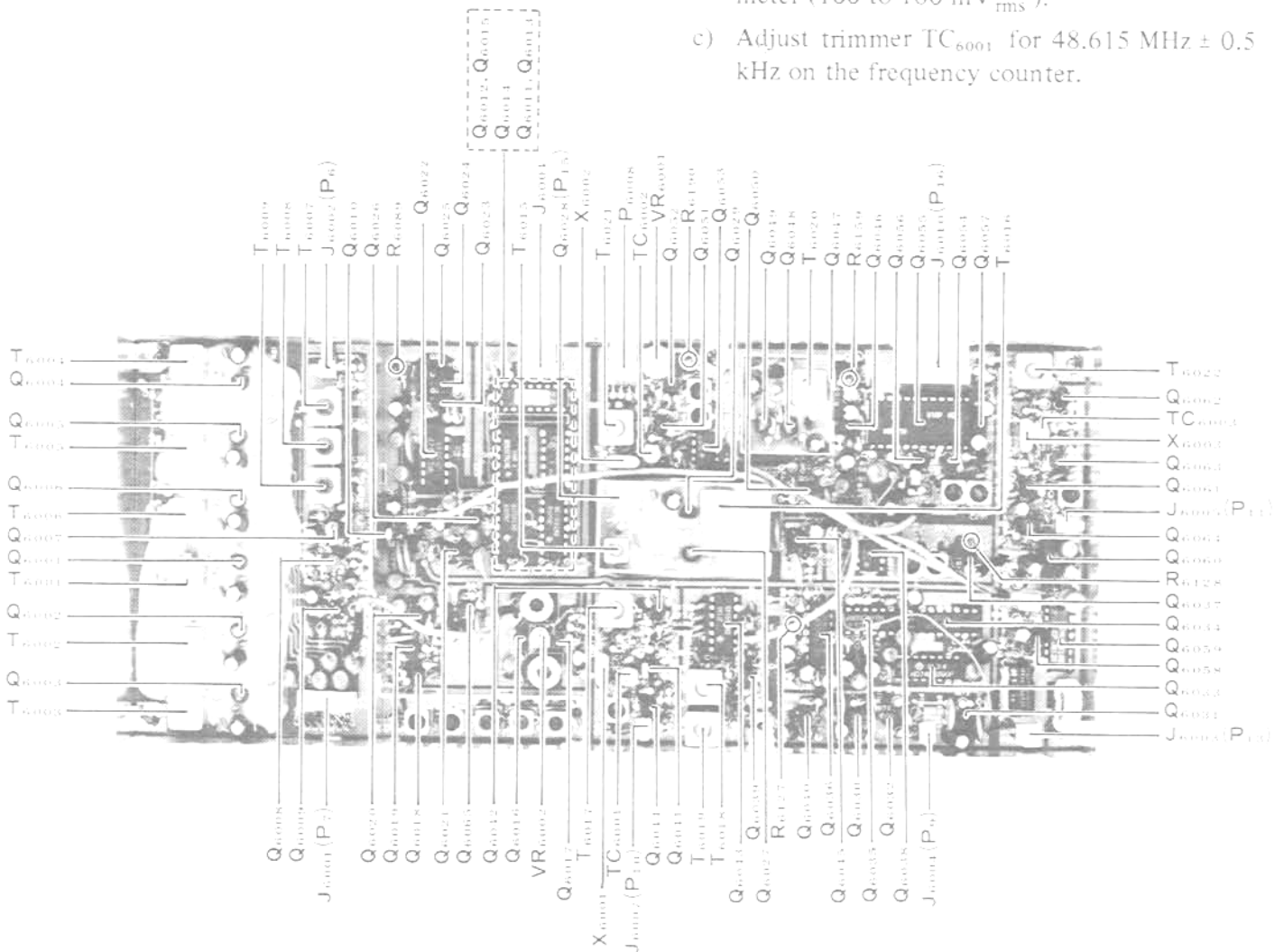

PLL UNIT (PB-2257)

(3) PLL Local Oscillator (54.28 MHz)

- a) Connect the RF probe of the voltmeter and the frequency counter to the hot lead of resistor R_{6190} .
- b) Adjust T_{6021} for maximum deflection on the meter (100 to 160 mV_{rms}).
- c) Adjust trimmer TC_{6002} for 54.28 MHz \pm 100 Hz on the counter.

***(4) VCO1 (22.0 to 22.99 MHz)**

VCO1 is located on the Local Unit.

- a) Connect the DC voltmeter to TP_{3004} on the Local Unit.
- b) Set the transceiver frequency to exactly 10.0000 MHz.
- c) Adjust T_{3013} for 6.0 V \pm 0.25 V on the meter.
- d) Now set the transceiver frequency to 10.0099 MHz, and check that the voltmeter reads approximately 3.6 V.
- e) Connect the RF probe of the voltmeter to pin 35 of edge connector MJ8, and check that the RF voltmeter shows 40 to 80 mV_{rms} .

(5) VCO2 (56.280 to 57.270 MHz)

- a) Connect the RF probe of the voltmeter to the lead of R_{6159} that connects to the collector of Q_{6047} .
- b) Set the transceiver frequency to 10.0000 MHz.
- c) Adjust T_{6020} for 5.5 V \pm 0.25 V on the meter.
- d) Now set the frequency to 10.9999 MHz and check that the voltmeter reads approximately 4 V.

(6) VCO3 (105.115 to 106.11499 MHz)

- a) Connect the DC voltmeter to the lead of R_{6127} that connects to R_{6123} , and connect the frequency counter to the source of Q_{6016} .
- b) With the transceiver frequency set to 10.9999 MHz, adjust T_{6016} for 6.0 V on the meter. Check that the counter shows approximately 106.115 MHz.
- c) Set the transceiver frequency to 10.0000 MHz.

- d) Check that the voltmeter reads approximately 4.7 V, and that the counter reads 105.115 MHz.
- e) Now disconnect the frequency counter and connect the RF probe of the voltmeter to the same point.
- f) Set the frequency to 0.5000 MHz and adjust T_{6015} for maximum deflection on the RF voltmeter (nom.: 1.0 \pm 0.3 V_{rms}).

(7) VCO4 (73.115 to 102.11499 MHz)

- a) Connect the DC voltmeter to either lead of R_{6089} .
- b) Set the transceiver frequency to 4.9999 MHz and adjust T_{6004} for 7.0 V on the meter.
- c) Set the frequency to 0.0000 MHz and check that the meter shows approximately 2.4 V.
- d) Now set the frequency to 9.9999 MHz and adjust T_{6005} for 7.0 V on the meter.
- e) Set the frequency to 5.0000 MHz and check for a reading of approximately 2.2 V on the meter.
- f) Set the frequency to 14.9999 MHz and adjust T_{6006} for a reading of 7.0 V on the meter.
- g) Set the frequency to 10.0000 MHz and check that the meter shows approximately 2.6 V.
- h) Set the frequency to 19.9999 MHz and adjust T_{6003} for a reading of 7.0 V on the meter.
- i) Set the frequency to 15.0000 MHz and check that the meter shows approximately 2.8 V.
- j) Set the frequency to 24.9999 MHz and adjust T_{6002} for a reading of 7.0 V on the meter.
- k) Set the frequency to 20.0000 MHz and check that the meter shows approximately 2.4 V.
- l) Set the frequency to 29.9999 MHz and adjust T_{6001} for a reading of 7.0 V on the meter.
- m) Set the frequency to 25.0000 MHz and check that the meter shows approximately 2.5 V.

(8) First Local LPF

- a) Connect the RF probe of the voltmeter to pin 1 of J_{6002} and set the transceiver to 29.9999 MHz.
- b) Adjust T_{6007} – T_{6009} for maximum deflection on the meter.

(9) 10 kHz Reference Signal

- a) Connect the RF probe of the voltmeter to pin 32 of edge connector MJ8, and check that $420 \pm 100 \text{ m V}_{\text{rms}}$ is shown on the meter.

LOCAL CIRCUIT

Before commencing with these procedures the WIDTH and SHIFT controls must be set to the center position.

(1) Carrier Oscillator (24.5 MHz)

- a) Connect the frequency counter to TP₃₀₀₆ on the Local Unit, and set the MODE selector to the FSK position and the VOX control to the MOX position. Short the FSK jack on the rear panel.
- b) Adjust VR₃₀₀₇ for 24.502295 MHz on the counter.
- c) Remove the short on the FSK jack and adjust VR₃₀₀₆ for 24.502125 MHz on the counter.
- d) Now switch the VOX control to PTT (receive) and switch the MODE selector to a CW position.

- e) Adjust VR₃₀₀₄ for 24.5 MHz \pm 100 Hz on the counter.
- f) Set the VOX control to the MOX position, and adjust VR₃₀₀₅ for 24.4992 MHz \pm 100 Hz on the counter. Return the VOX control to the PTT position.

(2) Carrier Oscillator (15.5 MHz)

Note that the alignment for production lots 001 through 005 is slightly different than for prod. lot 6 and later lots. Alignment information particular to the earlier models is indicated by a double asterisk (**).

- a) Connect the frequency counter to TP₃₀₀₂ on the Local Unit.
- b) Set the MODE selector to the LSB position and adjust trimmer TC₃₀₀₂ (**TC₃₀₀₁) for 15.5140 MHz \pm 100 Hz on the counter. (**On Lots 001 through 005 the adjustment range of TC₃₀₀₁ may be insufficient to obtain this frequency, in which case the Local Unit should be raised with the extender card and T₃₀₀₅ adjusted for this frequency. It is not necessary to readjust TC₃₀₀₁ afterward.)

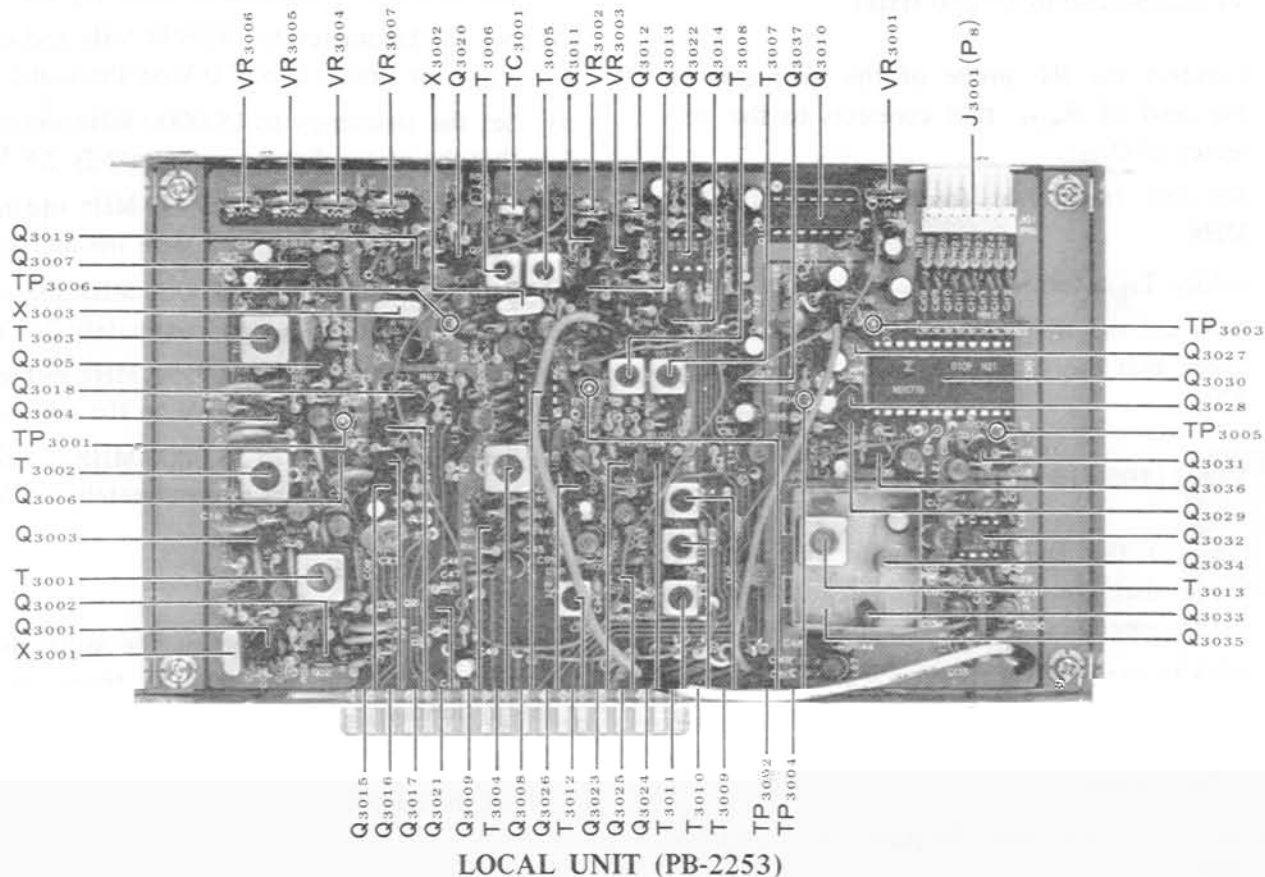

- c) Set the MODE selector to the USB position and adjust TC₃₀₀₁ (**VR₃₀₀₃) for 15.5110 MHz \pm 100 Hz on the counter.
- d) Set the MODE selector to the AM position and adjust VR₃₀₀₂ for 15.5125 MHz \pm 100 Hz on the counter.
- e) Set the MODE selector to the LSB position, key the transmitter, and adjust VR₃₀₀₁ (**TC₂₃₀₂ on the TX CAR OSC Unit) for 15.5140 MHz \pm 100 Hz on the counter.

This completes the alignment for prod lots 006 and up. For lots 001 through 005, the following steps must also be performed.

- f) (**) Set the MODE selector to the USB position key the transmitter, and adjust TC₂₃₀₃ on the TX CAR OSC Unit for 15.5110 MHz \pm 100 Hz on the counter.
- g) (**) Set the MODE selector to the AM position, key the transmitter, and adjust TC₂₃₀₁ on the TX CAR OSC Unit for 15.5125 MHz \pm 100 Hz on the counter.

***(3) Carrier Mixer**

- a) Connect the RF probe of the voltmeter to pin 16 of MJ8.
- b) Adjust T₃₀₀₄ for maximum deflection on the meter. (nom.: 220 \pm 40 mV.)

***(4) Second Local Mixer**

- a) Connect the RF probe of the voltmeter to pin 17 of MJ8.
- b) Adjust T₃₀₀₇–T₃₀₁₂ for maximum deflection on the meter (nom.: 220 \pm 60 mV).

RECEIVER

***[1] Front End**

- a) Connect the 4 ohm dummy load and the AF millivoltmeter to the SP jack on the rear panel, and connect the standard signal generator (SSG) to the ANT jack.
- b) Set the transceiver frequency to 14.2500 and set the SSG on the same frequency with an output level of 0 dB (1 μ V), and 1 kHz modulation.
- c) Set the MODE selector to USB and adjust T₁₀₀₈ on the RF Unit for maximum deflection on the meter.

[2] IF Amplifiers

Set the MODE selector to USB, and the RF GAIN control fully clockwise. Also set the RF ATT control fully counter-clockwise. Keep the SSG connected as in the Front End alignment, above, throughout the IF Amplifier alignment.

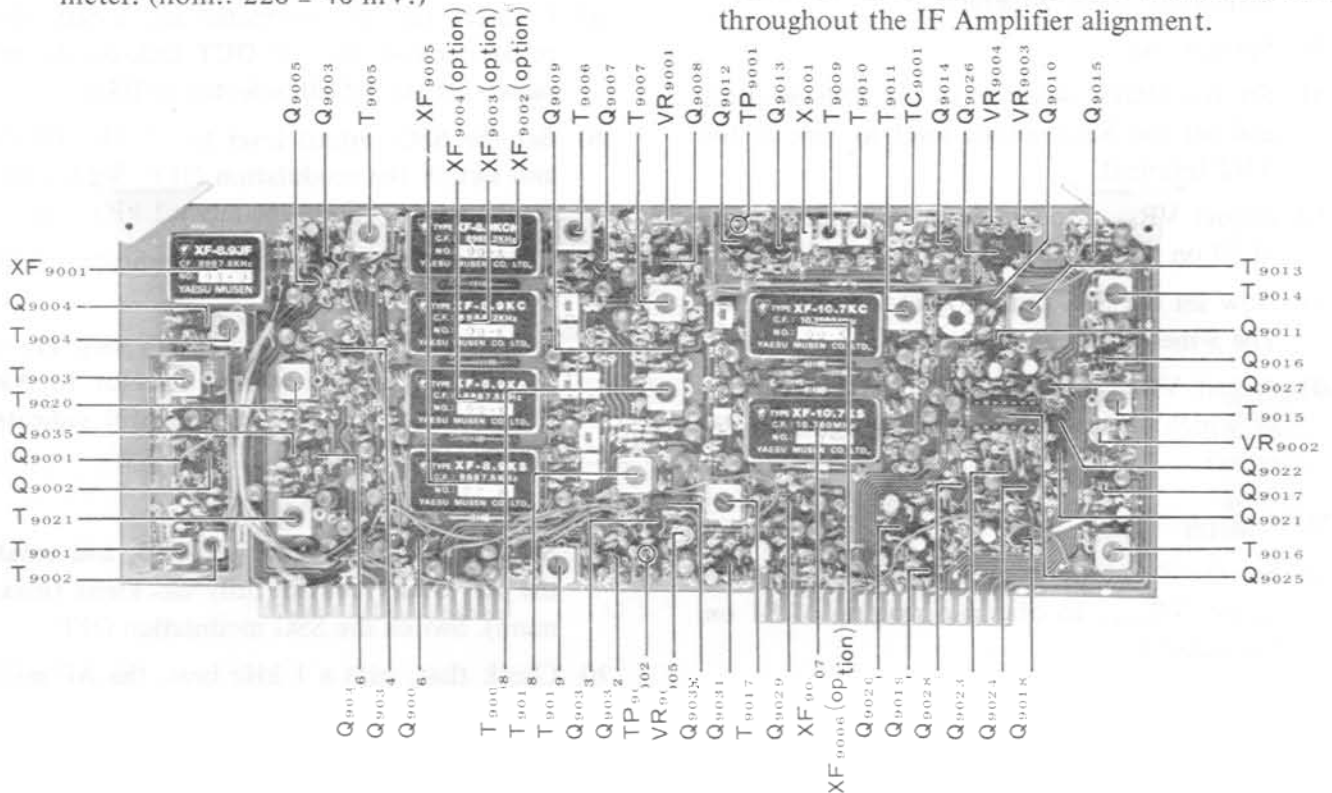

IF UNIT (PB-2255)

- (1) Width and Shift
 - a) Set the WIDTH and SHIFT controls on the front panel to their center positions.
 - b) Connect the frequency counter to TP₉₀₀₁ on the IF Unit.
 - c) Adjust trimmer TC₉₀₀₁ for 19.7475 MHz \pm 100 Hz on the counter.

* (2) IF Coils

- a) With the transceiver and SSG set on 14.2500 MHz, as above, set the AGC switch on the front panel to the FAST position.
- b) Now set the SSG output level for an S-meter reading of 3 on the FT-ONE.
- c) Adjust T₉₀₀₁, T₉₀₀₂, T₉₀₀₃, T₉₀₀₅, T₉₀₀₇, T₉₀₀₈, T₉₀₁₁, T₉₀₁₃, T₉₀₁₄, T₉₀₁₅, and T₉₀₁₆ (in this order) for maximum deflection on the S-meter.

* (3) CW(N) Filter Compensation Amplifier

This procedure is to be performed when the optional XF8.9KCN is installed.

- a) Set the MODE selector to the CW(N) position, and tune the SSG frequency to obtain maximum deflection on the S-meter.
- b) Now adjust the SSG output level to provide an S-meter reading of S3 on the transceiver.
- c) Adjust T₉₀₀₆ on the IF Unit for maximum deflection on the S-meter.

(4) System Gain

- a) Set the MODE selector to the USB position, and set the SSG output level to 20 dB at the ANT terminal.
- b) Adjust VR₉₀₀₄ to obtain an S-meter reading of S3 on the transceiver.
- c) Now set the SSG output level to 0 dB (1 μ V). The S-meter should still read S3.
- d) Adjust VR₉₀₀₁ to the point just before that at which the S-meter reading begins to decrease.

(5) S-meter

- a) Set the SSG output level to 6 dB (2 μ V), and adjust VR₉₀₀₄ to obtain a reading of S1 on the S-meter.
- b) Now set the SSG output level to 90 dB (31.6 mV), and adjust VR₉₀₀₃ to obtain a full scale reading on the S-meter.

- c) Repeat steps a) and b) several times.
- d) Check that the output level of the SSG is between 24 and 36 dB when the S-meter reads S9.

[3] AF Circuit

For the following procedures (except for procedure (2)), connect the 4 ohm dummy load and the AF voltmeter to the SP jack on the rear panel, and the SSG to the ANT terminal. The AGC switch should be set to the FAST position.

(1) AF Gain

- a) Set the SSG output level to 20 dB (10 μ V) at the same frequency as the transceiver, and set the MODE selector to USB. Set the AF GAIN control to the 9 o'clock position.
- b) Adjust the SSG frequency slightly to obtain approximately a 1 kHz beat, and check that the audio output level is between 350 and 900 mV (30 to 200 mW).
- c) Maintaining the same SSG output level and frequency, modulate the signal at 400 Hz with 40% modulation.
- d) Set the MODE selector to AM. The AF voltmeter should read between 350 and 900 mV (30 to 200 mW).

(2) AF Output Level

- a) Connect the AF voltmeter and a 50K ohm resistor across the AF OUT jack on the rear panel. Set the MODE selector to USB.
- b) Set the SSG output level to 20 dB (10 μ V) and switch the modulation OFF. Set the SSG frequency for approximately a 1 kHz beat.
- c) Check that the AF voltmeter indicates 300 to 500 mV.
- d) Switch on the modulator as in step (1) c) above, and set the MODE selector to AM. Check that the AF voltmeter still indicates 300 to 500 mV.

(3) AF Power Amplifier

- a) Set the MODE selector to USB, and rotate the AF GAIN control fully clockwise (maximum). Switch the SSG modulation OFF.
- b) Check that, with a 1 kHz beat, the AF millivoltmeter indicates at least 3.5 V (3 W).

[4] PLL Mixer

- a) Connect the SSG to the ANT jack, with output level of 90 dB (32 mV) at 1.885 MHz.
- b) Set the MODE selector to USB and tune the transceiver around 1.865 MHz for an audible beat.
- c) Adjust VR₆₀₀₂ on the PLL Unit for minimum S-meter deflection.

***[5] Noise Blanker**

For this alignment, set the MODE selector to USB and the NB switch ON.

(1) Noise Blanker LO

- a) Connect the frequency counter and the RF probe of the voltmeter to the second gate of Q₃₀₀₂ on the Local Unit.
- b) The frequency counter should show 9.4425 MHz \pm 1.0 kHz.
- c) The RF voltmeter should show 2.5 V \pm 1.0 V_{rms}.

(2) Noise Blanker IF Coils

- a) Connect the DC voltmeter to TP₃₀₀₁ on the Local Unit and temporarily short the base of Q₃₀₀₇ to ground.
- b) Set the SSG to 14.2250 MHz and tune the transceiver to this frequency.
- c) Turn the AGC switch OFF and adjust the SSG output so that the DC voltmeter shows -1 V.
- d) Adjust T₃₀₀₁-T₃₀₀₃, and T₉₀₀₄ for maximum deflection on the voltmeter (negative voltage).

[6] FM Unit—Receiver Section*(1) Receiver Local Oscillator**

- a) Connect the frequency counter to 1K resistor R₂₁₀₈, and adjust trimmer TC₂₁₀₁ for 9442.5 kHz \pm 100 Hz.

(2) IF Amplifier Coils

- a) Set the transceiver frequency to 14.2500 MHz and connect the SSG to the ANT connector. the AF millivoltmeter to the speaker terminals.
- b) Set the SSG for an output level of -8 dB μ at the same frequency, and adjust T₂₁₀₁ through T₂₁₀₃ for minimum deflection on the millivoltmeter.

(3) Squelch Preset

- a) Set the SQL control on the front panel to the 10 o'clock position and adjust VR₂₁₀₁ on the FM Unit so that the squelch is just closed (with no input signal).

(4) DISC Meter Adjustment

- a) With the METER selector set to DISC, adjust VR₂₁₀₂ so that the METER I needle indicates exactly at the center of the scale (with no input signal).

(5) DISC Meter Sensitivity Adjustment

- a) Connect the SSG as in step (2)a) above, and set for an output level of 20 dB μ at 14.2500 MHz.
- b) Tune the transceiver VFO for maximum deflection of the meter (METER I).
- c) Adjust VR₂₁₀₃ for a deflection on METER I coinciding with the 15A marking on the IC scale (METER I indicating DISC).

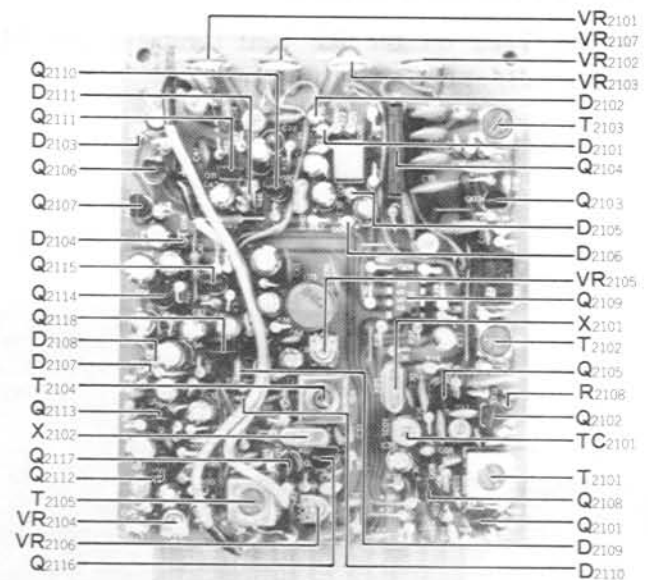
(6) Repeat steps (4) and (5).**FM UNIT (PB-2254)**

TRANSMITTER

For the following procedures connect the dummy load/wattmeter to the ANT terminal, and the audio generator to the MIC jack. Set the audio generator to 1 kHz at 1 mV output level. Set the MODE selector to the USB position, and the transceiver frequency to 28.5000 MHz. Set the MIC GAIN fully clockwise (maximum) unless otherwise noted.

[1] TX Coils

* (1) Balanced Modulator Transformer

- a) Connect the RF probe of the voltmeter to pin 3 of edge connector MJ10.
- b) Close the PTT line (VOX control to MOX position) and adjust T₄₀₀₁ on the AF Unit for maximum deflection on the RF voltmeter.

* (2) TX First IF Transformers

- a) Connect the RF probe of the voltmeter to pin 9 of edge connector MJ6.
- b) Set the VOX control to the MOX position and adjust T₉₀₀₂, T₉₀₁₉, T₉₀₂₀ and T₉₀₂₁ for maximum deflection on the RF voltmeter.

* (3) TX Second IF Transformer

Adjust T₁₀₁₀ on the RF Unit for maximum RF power output on the wattmeter.

[2] Directional Coupler

- a) Set the METER selector to the REF position, and the FWD SET control fully clockwise (maximum).
- b) Set the VOX control to the MOX position and adjust trimmer TC₇₁₀₁ on the ALC Unit for minimum deflection on the transceiver REF indicating Meter (METER 1).

[3] Carrier Balance

This alignment requires an external receiver.

- a) Set the transceiver frequency to 14.2500 MHz, and the MODE selector to USB.
- b) Set the MIC GAIN control fully counter-clockwise (minimum), and remove the audio generator from the MIC jack.
- c) Set the VOX control to the MOX position, and tune the external receiver to the carrier frequency.
- d) Adjust VR₄₀₀₈ on the AF Unit for minimum S-meter deflection on the external receiver.
- e) Set the MODE selector to LSB and again adjust VR₄₀₀₈ for a minimum.
- f) Repeat steps d) and e) several times in USB and LSB alternatively to obtain the same minimum carrier level in both modes.

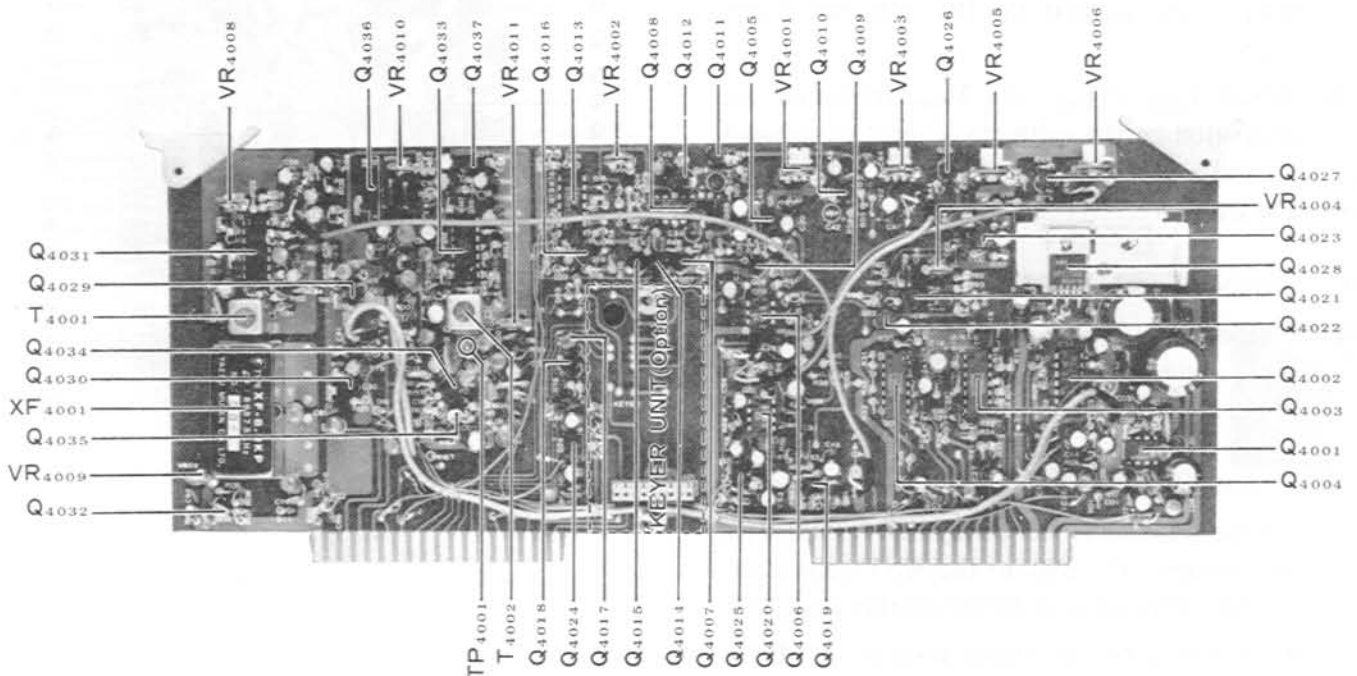

AF UNIT (PB-2252)

***[4] ALC Level**

- a) Set the transceiver frequency to 28.5000 MHz, and the VOX control to the MOX position. Adjust VR₇₁₀₂ on the ALC Unit for a reading of 90 W on the RF wattmeter.
- b) Set the transceiver frequency to 24.5000 MHz, and adjust VR₇₁₀₃ on the ALC Unit for 100 W on the RF wattmeter.

***[5] Overall Gain**

- a) Set the MODE selector to the USB position, and connect the output of the AF generator to the MIC jack.
- b) Set the AF generator output level to 0.4 mV at 1 kHz, and set the VOX control to the MOX position.
- c) Adjust VR₄₀₀₉ to the point just before that at which the ALC meter begins to deflect.

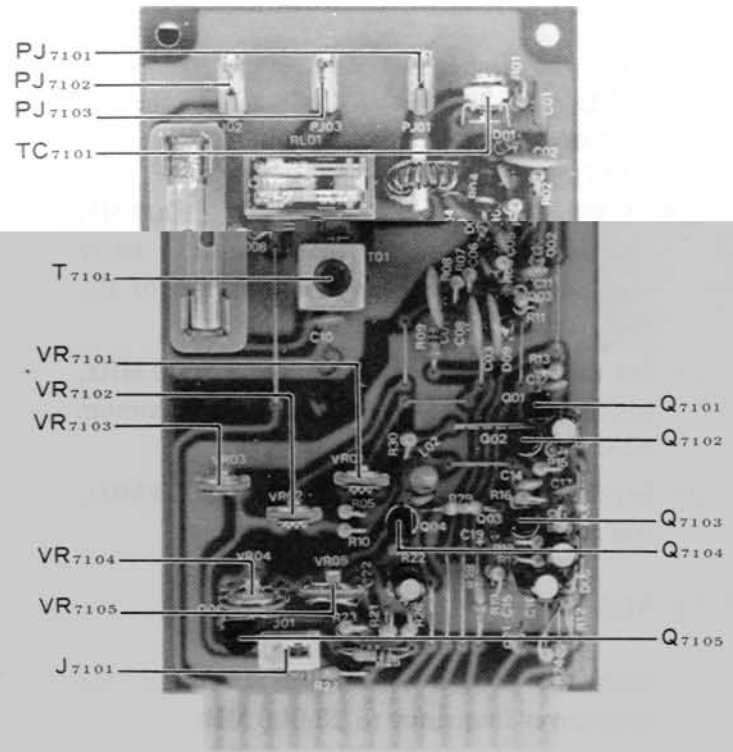

ALC UNIT (PB-2260)

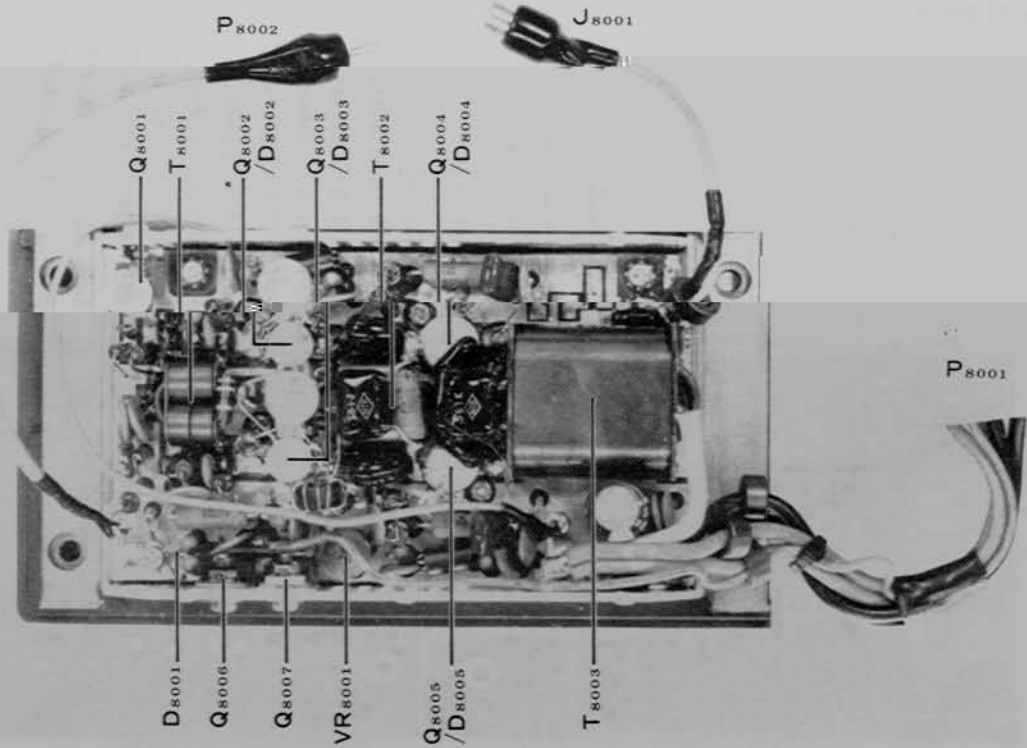

100W PA UNIT (PB-2321)

[6] Transmit Level

- a) Set the transceiver frequency to 14.2500 MHz, and adjust VR₁₀₀₂ so that the ALC meter deflects to the maximum edge of the ALC zone on the meter.
- b) Set the transceiver frequency to 7.1000 MHz, and adjust VR₁₀₀₄ so that the ALC meter again deflects to the maximum edge of the ALC zone.
- c) Set the transceiver frequency to 3.5000 MHz, and adjust VR₁₀₀₇ for the same maximum ALC point.
- d) Set the transceiver frequency to 1.8000 MHz, and adjust VR₁₀₀₉ in the same manner.

*[7] ALC Meter

- a) With the MODE selector in USB, set the transceiver frequency to 28.000 MHz.
- b) Set the VOX control to the MOX position and adjust the output level of the AF generator to the point where it is 10 dB above that at which the ALC meter just begins to deflect.
- c) Adjust VR₇₁₀₄ on the ALC Unit so that the ALC meter needle points within the right side of the ALC zone.

*[8] Speech Processor

*(1) Compression Amplifier

- a) With the transceiver frequency set to 28.0000 MHz, turn the PROC switch ON.
- b) Set the AF generator output level to 2 mV at 1 kHz, and adjust the DRIVE control for a comfortable reading on the output wattmeter.
- c) Set the METER selector to the COMP position and the COMP gain control fully clockwise (maximum). Adjust the MIC GAIN control so that the COMP reading is about 10 dB on the COMP scale of the meter.
- d) Adjust T₉₀₁₇ on the IF Unit for maximum deflection on the COMP meter.
- f) Adjust T₉₀₁₈ for maximum deflection on the output wattmeter.

*(2) Compression Level

- a) Set the MIC GAIN, COMP gain and DRIVE controls all fully clockwise (maximum).
- b) Set the AF generator output level to 1 mV at 1 kHz, and adjust VR₉₀₀₅ so that the ALC meter needle indication is within the right side of the ALC zone.

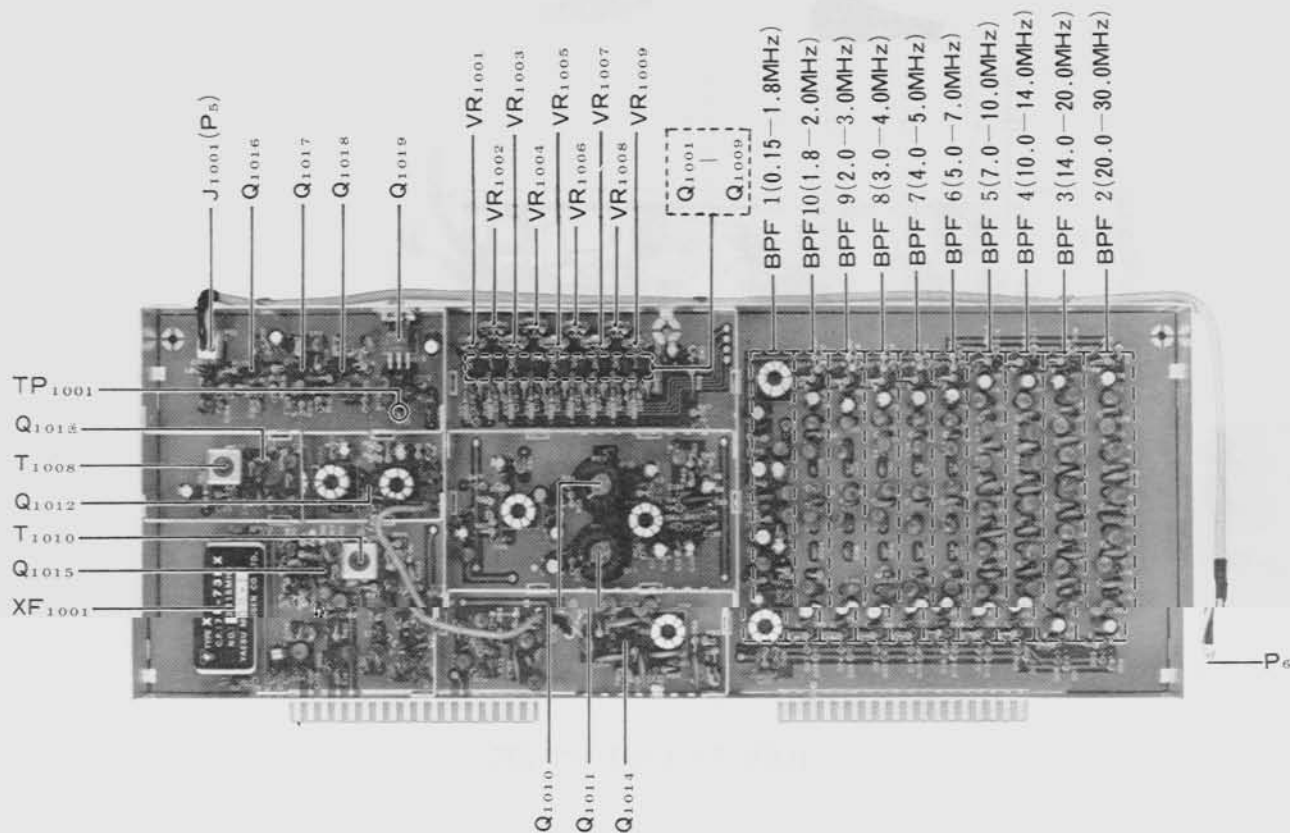

RF UNIT (PB-2256)

[9] AMGC

(1) AMGC Gain

- a) Connect the DC voltmeter to pin 10 of Q₄₀₀₈ on the AF Unit, and set VR₄₀₀₁ fully counter-clockwise.
- b) Set the VOX control to the MOX position, and adjust VR₄₀₀₁ just to the point where the DC voltmeter indicates the shift from the low level (0 V) to high (5.5 V).

(2) AMGC Delay

This adjustment can be set to individual operator and environmental requirements. Adjust VR₄₀₀₂ on the AF Unit for the desired "hang" time after speaking into the microphone. Clockwise rotation increases the delay period.

[10] CW Sidetone

(1) Sidetone Pitch

- a) Set the MODE selector to a CW position, and turn the MONI switch ON.
- b) Close the keying line and adjust VR₄₀₀₄ on the AF Unit for the desired pitch. (This is normally set to around 800 Hz).

(2) Sidetone Level

- a) With the controls set as in the previous step, adjust VR₄₀₀₅ on the AF Unit for comfortable sidetone volume.

*[11] AM Circuit

(1) AM Modulator

- a) Connect the RF probe of the voltmeter to TP₄₀₀₁ on the AF Unit.
- b) Set the MODE selector to the AM position, and reduce the output level of the AF generator to nil.
- c) Adjust T₄₀₀₂ for maximum deflection on the RF voltmeter.

(2) Carrier Level

- a) With the transmitter frequency at 28.0000 MHz and the MODE selector in AM, set the MIC GAIN control fully counter-clockwise (minimum) and the DRIVE control fully clockwise (maximum).
- b) Adjust VR₄₀₁₁ on the AF Unit so that the ALC meter just begins to deflect.

(3) AM Modulation Level

- a) Connect the vertical input of the oscilloscope to TP₄₀₀₁ on the AF Unit, and set the MIC GAIN control fully clockwise (maximum).
- b) Set the AF generator output level to 1.3 mV at 1 kHz, and adjust VR₄₀₁₀ so that the pattern indicating 100% modulation is displayed on the scope.

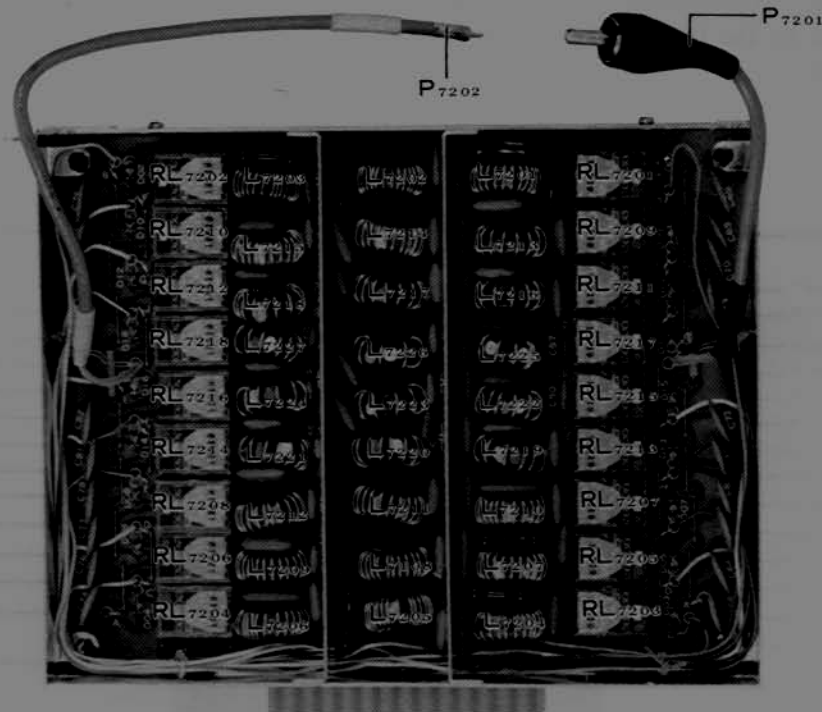

LPF UNIT (PB-2259)

[12] Monitor Level

- a) Set the MODE selector to LSB, and the MONI switch ON. Connect the headphones to the PHONES jack, and the microphone to the MIC jack.
- b) Close the PTT and speak into the microphone with a normal voice while adjusting VR₄₀₀₆ on the AF Unit for comfortable volume in the headphones.

*[13] IC Meter

- a) Connect the ammeter between pins 4 and 6 of the DC dummy plug on the rear of the transceiver.
- b) Set the transceiver to transmit on 14.2500 MHz in the FSK mode, and adjust the DRIVE control for 18 A on the ammeter.
- c) Set the METER selector to the IC position, and adjust VR₇₀₀₁ on the Regulator Unit for a reading of 15 on the IC scale.

[14] VOX Anti-Trip Level

- a) Preset the transceiver front panel controls for normal SSB operation, tune in a station on the receiver, and set the AF GAIN for a comfortable listening level.
- b) Preset the ANTI-TRIP control, VR₄₀₀₃, fully counter-clockwise (minimum). Place the microphone near to the loudspeaker (do not activate the PTT).

- c) Rotate the VOX GAIN control on the front panel gradually clockwise from its counter-clockwise (minimum) position just to the point where the transmitter is activated.
- d) Gradually rotate the ANTI-TRIP control, VR₄₀₀₃, clockwise to the point where the transmitter ceases to be activated by the audio from the loudspeaker.
- e) Now retune the transceiver to a clear frequency and speak into the microphone to ensure that the VOX activates the transmitter properly.

*[15] AFP Circuit

The following procedure must not be attempted without the proper 25 ohm dummy load, i.e.: two 50 ohm dummy loads in parallel.

- a) With the transceiver set at 28.0000 MHz and the MODE selector in a CW position, connect the 25 ohm dummy load to the ANT jack.
- b) Close the keying line, and adjust the DRIVE control so that the ALC meter needles rests at the center of the ALC zone.
- c) Adjust VR₇₁₀₁ on the ALC Unit to the point where the ALC meter needle just begins to move from its center position.

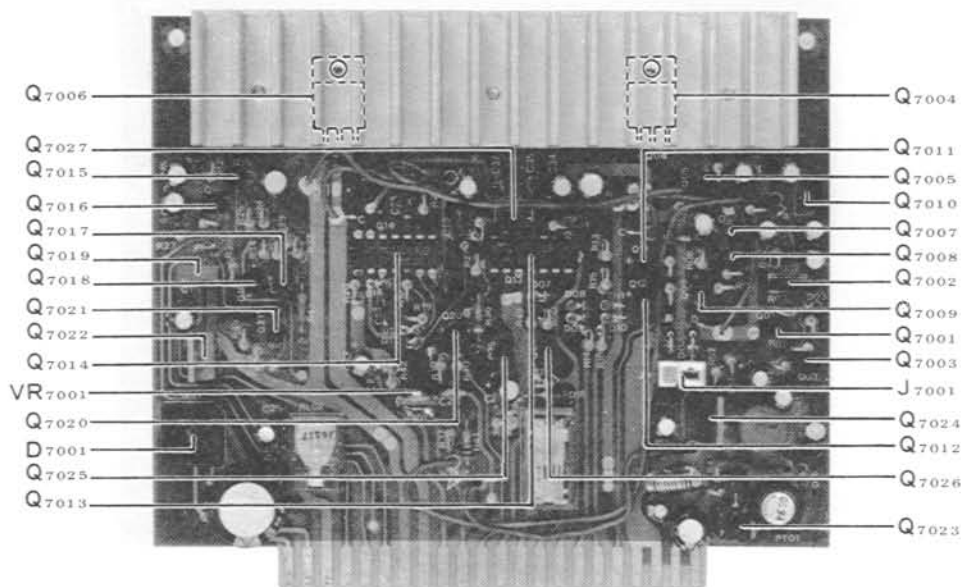

REG UNIT (PB-2258)

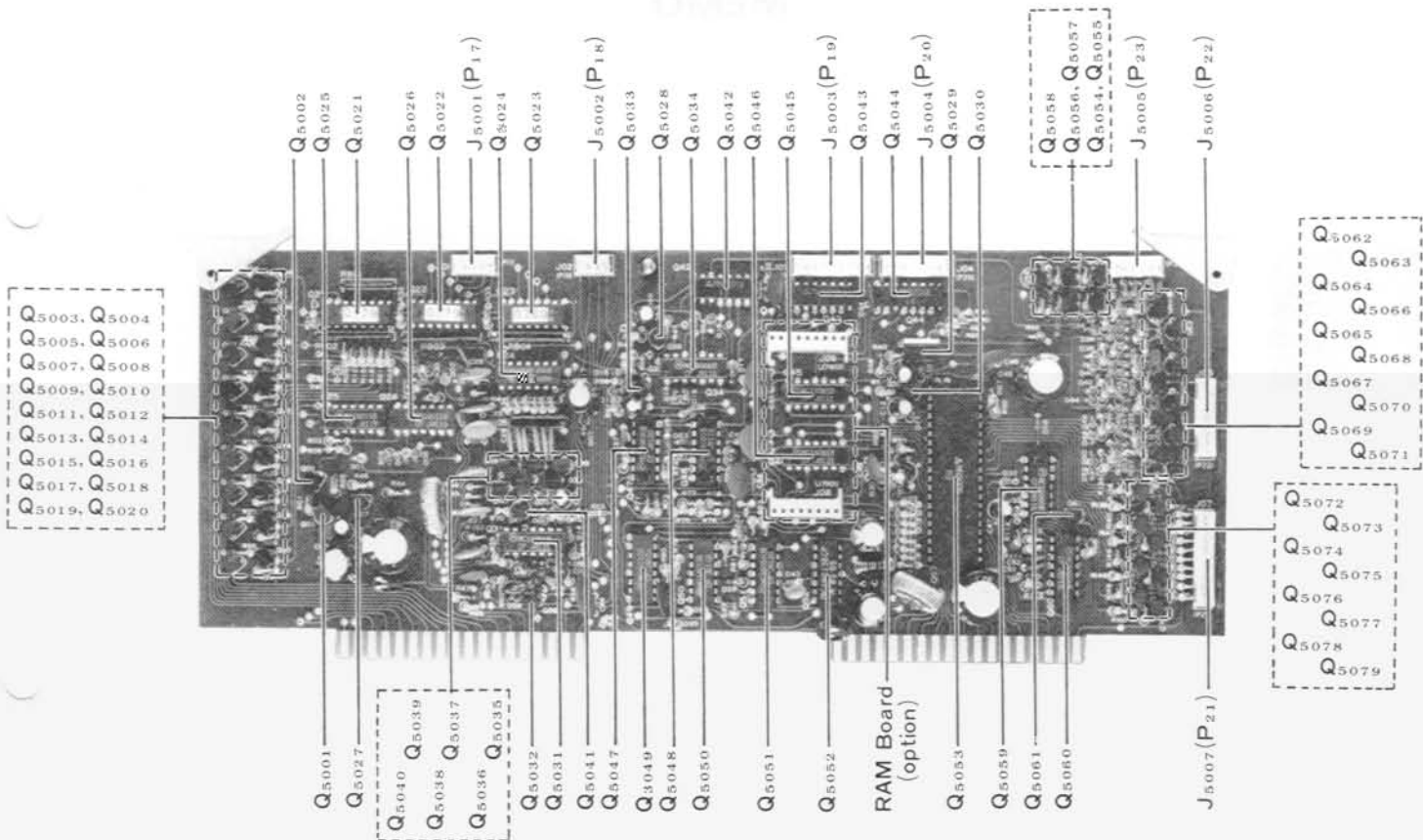

CONTROL UNIT (PB-2251)

* [16] FM Unit—Transmit Section

Preset potentiometers VR₂₁₀₄, VR₂₁₀₆ and VR₂₁₀₇ to their center positions, and key the transmitter (connected to a dummy load) for each of the following adjustments.

(1) Transmit Frequency Adjustment

- a) Connect the frequency counter to pin 10 of MJ7 (pin 9 is ground).

b) Adjust T₂₁₀₄ for a reading of 8987.5 kHz ± 500 Hz on the counter (with no microphone input).

(2) Buffer Amplifier Adjustment

- a) Connect the RF probe of the VTVM from pin 10 to pin 9 of MJ7. Adjust T₂₁₀₅ for maximum deflection on the VTVM.

(3) FM Transmit Level Adjustment

- a) Set the transceiver to 27 MHz and the DRIVE control fully clockwise. Adjust VR₂₁₀₆ to the point where ALC indication just begins on METER II.

(4) IDC Level Adjustment

- a) Connect the audio generator to the MIC input, and set for an output of 10 mV at 1 kHz. Connect the deviation meter through a directional coupler with the dummy load to the ANT terminal.
- b) Adjust VR₂₁₀₅ for a deviation of ± 5 kHz on the deviation meter.

(5) Microphone Input Sensitivity Adjustment

- a) With the audio generator connected to the MIC input, set for an output of 1 mV at 1 kHz. Use the same deviation meter connection as in step (4).
- b) Adjust VR₂₁₀₄ for a deviation of ± 3.5 kHz.

(6) Final Transmit Frequency Adjustment

- a) Remove the extender board and install the FM Unit back into position. Repeat step (1), adjust VR₂₁₀₇ for 8987.5 kHz ± 100 Hz on the counter (no microphone input).

MEMO



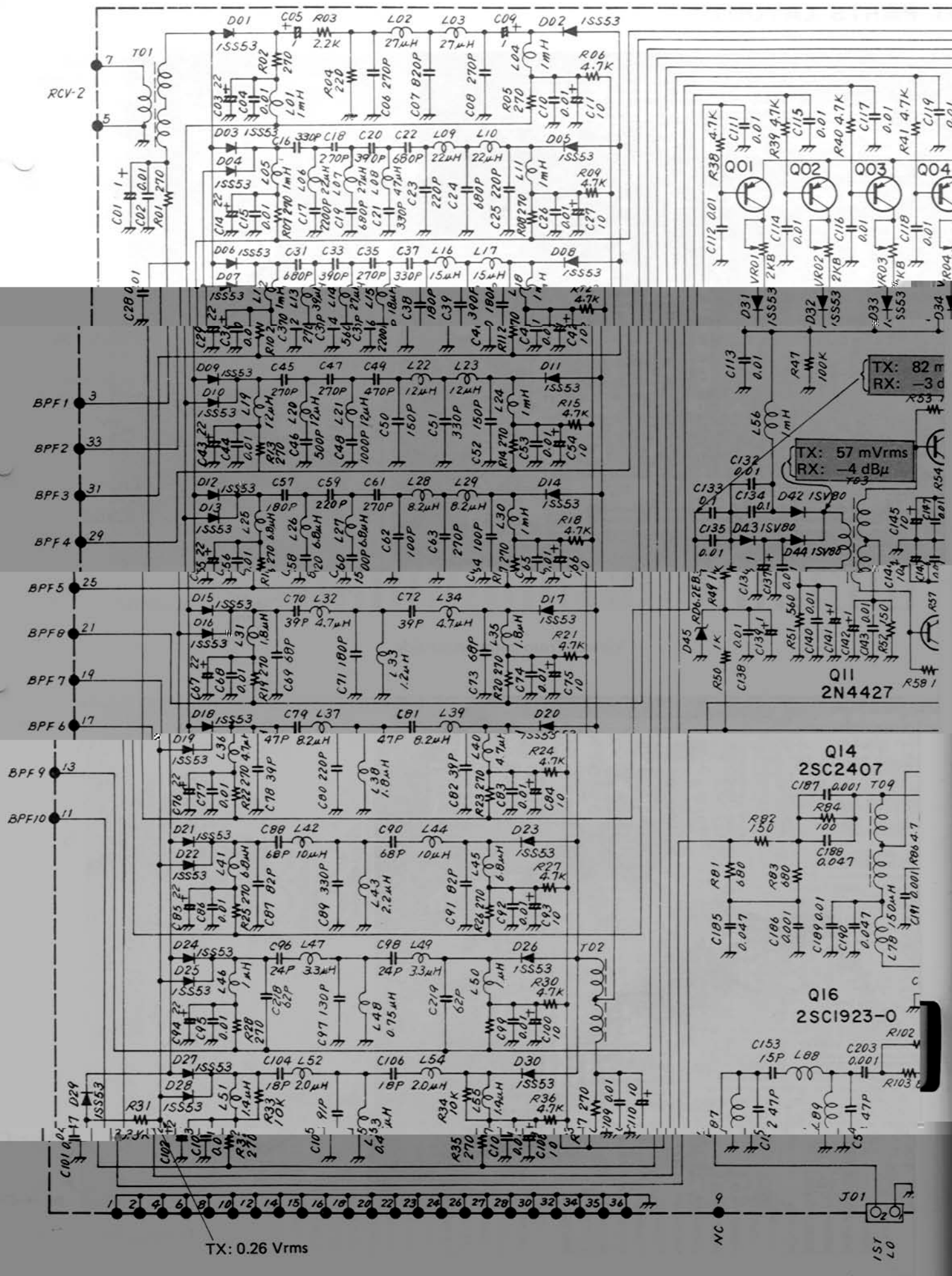

TX: 0.26 Vrms

RF UNIT PB-2256 (No.10..)

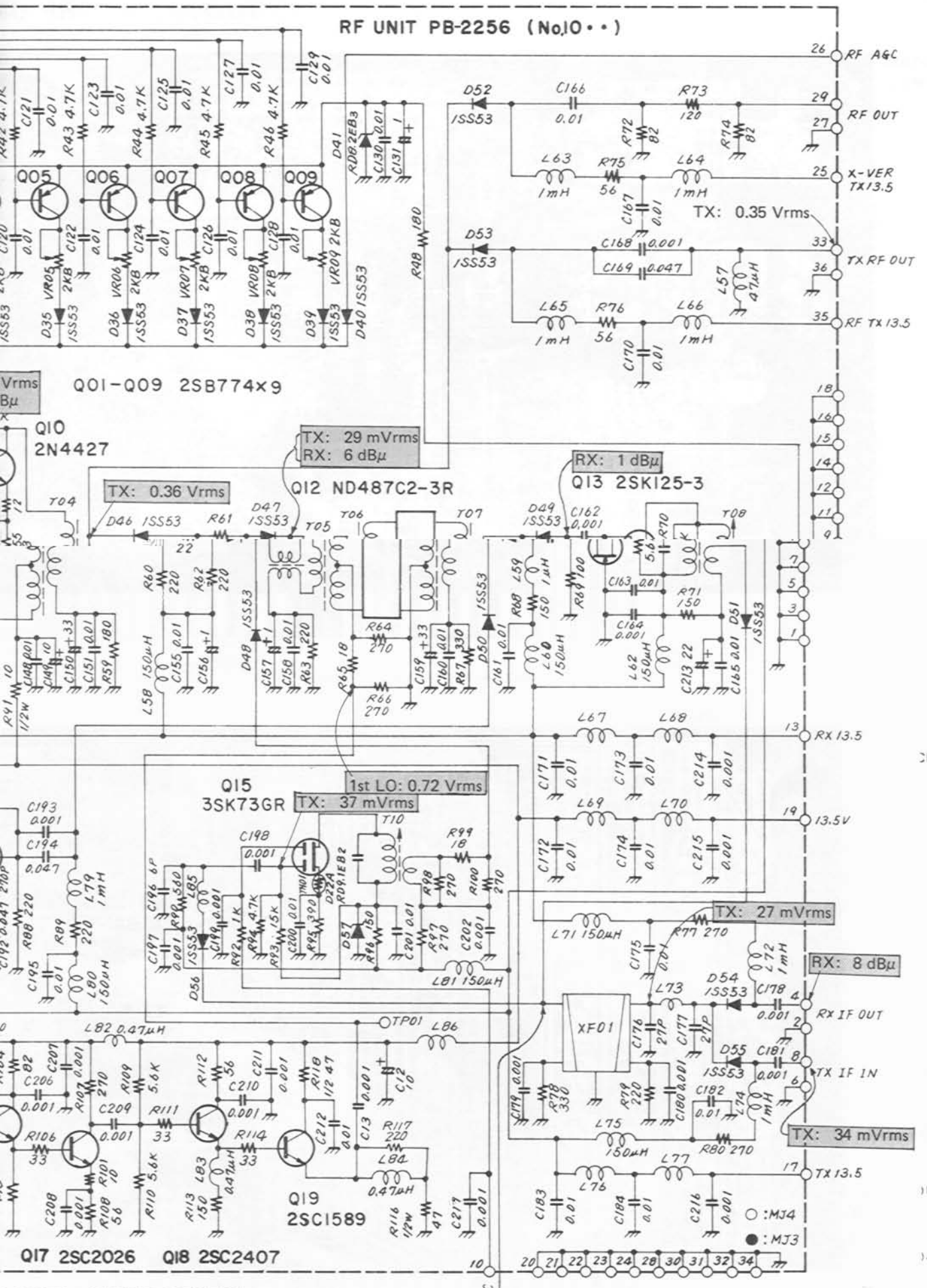

RF UNIT SIGNAL LEVELS

- TX: FREQUENCY; 14.2 MHz
- ANT OUTPUT; SSB 100 W, AM 25 W
- RX: FREQUENCY; 14.2 MHz
- ANT INPUT; 0 dBμ (1 μV)

TX: 23 mVrms
RX: 10 dBμ

ER
JE
11
14

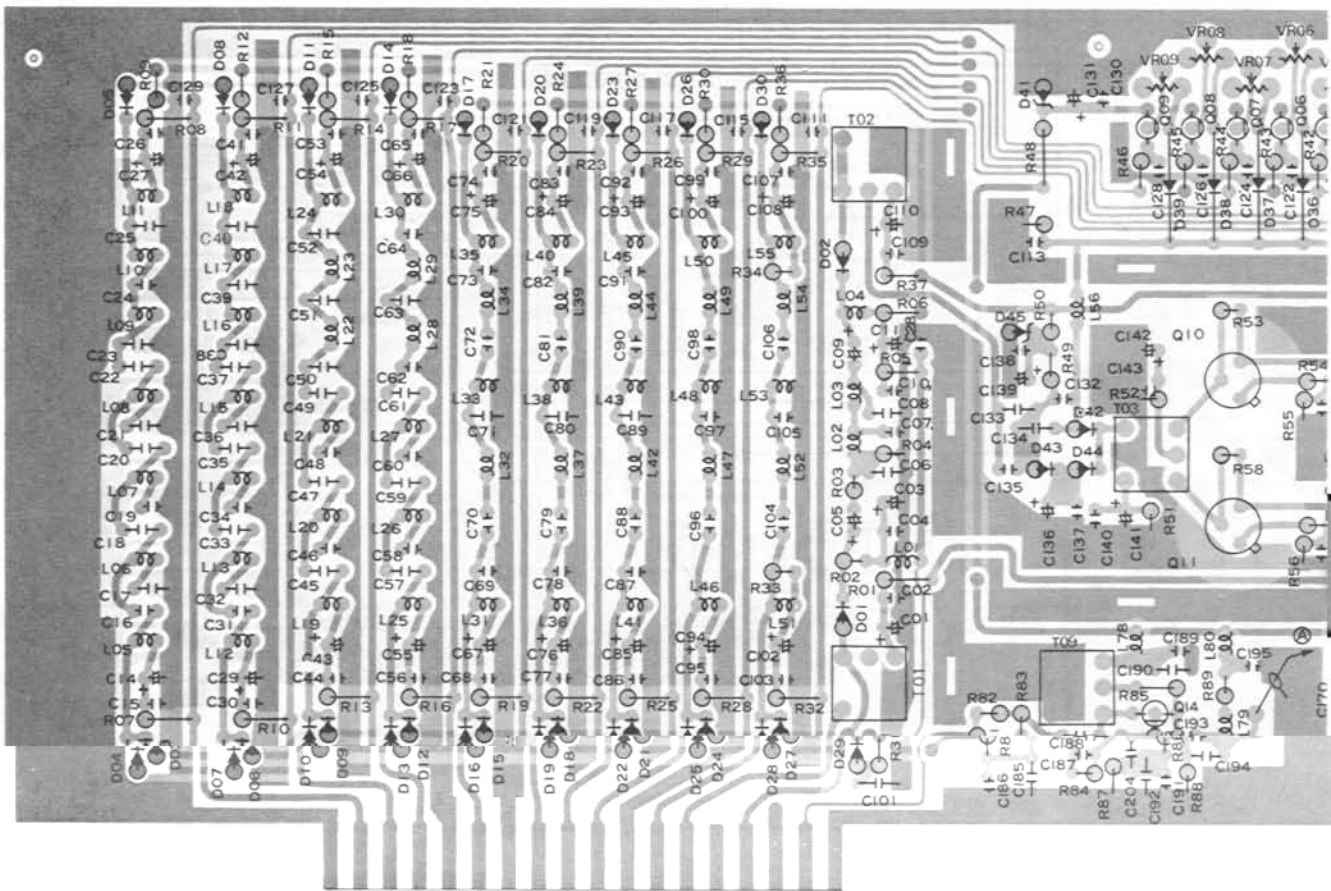
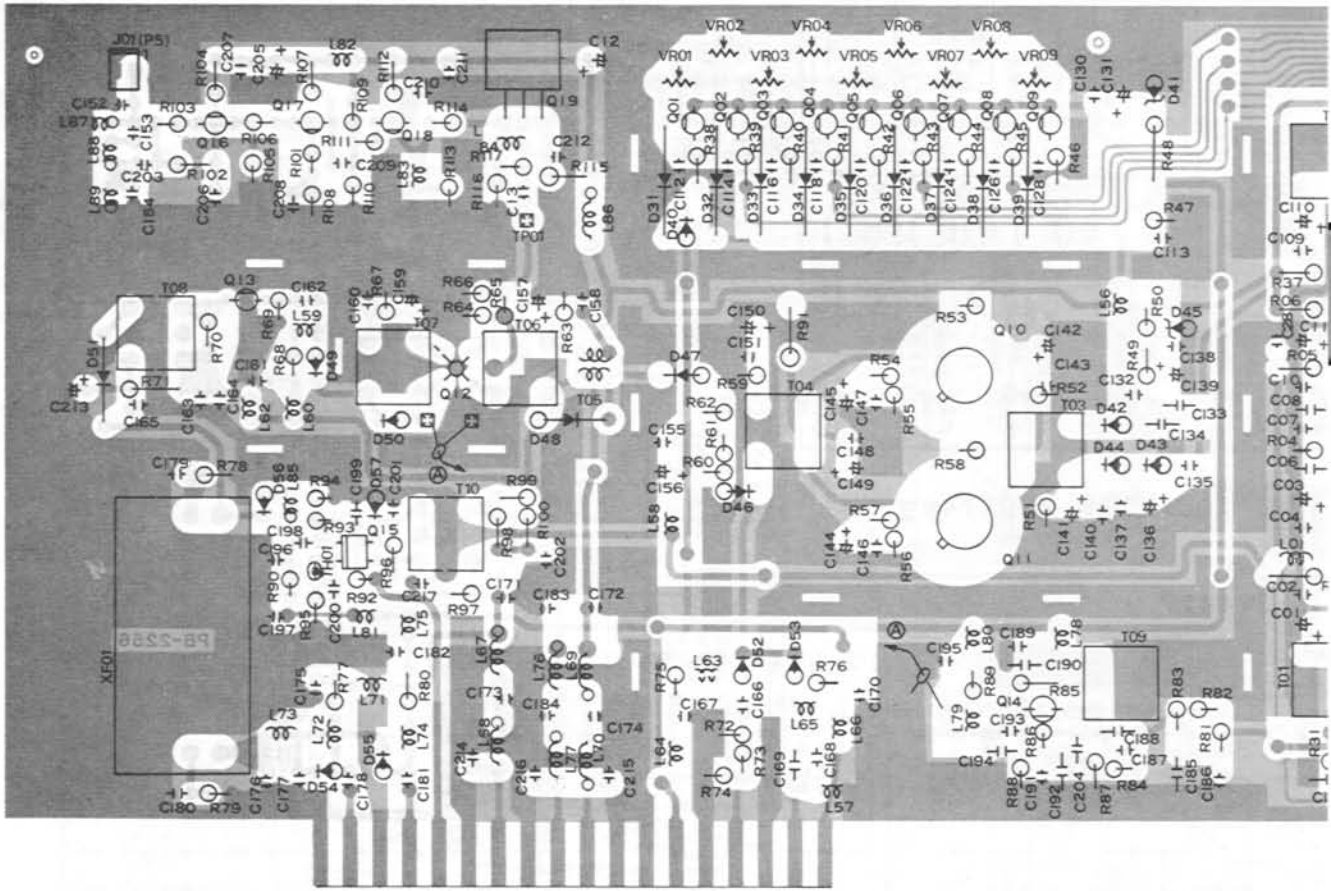

IIT PARTS LAYOUT

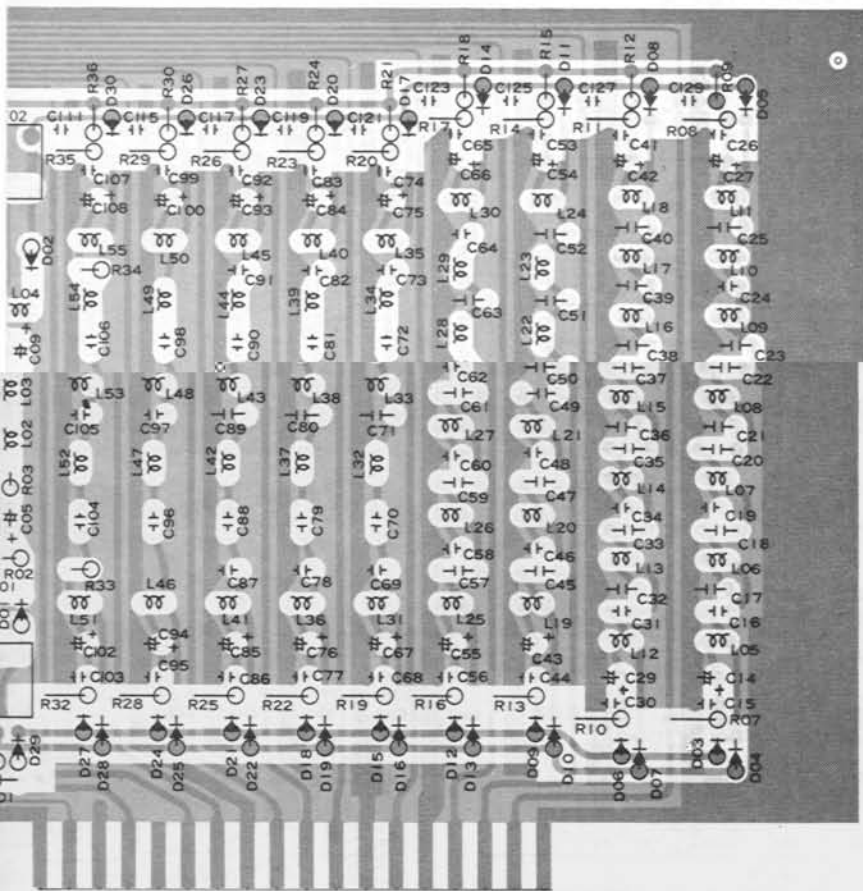

Viewed from component side

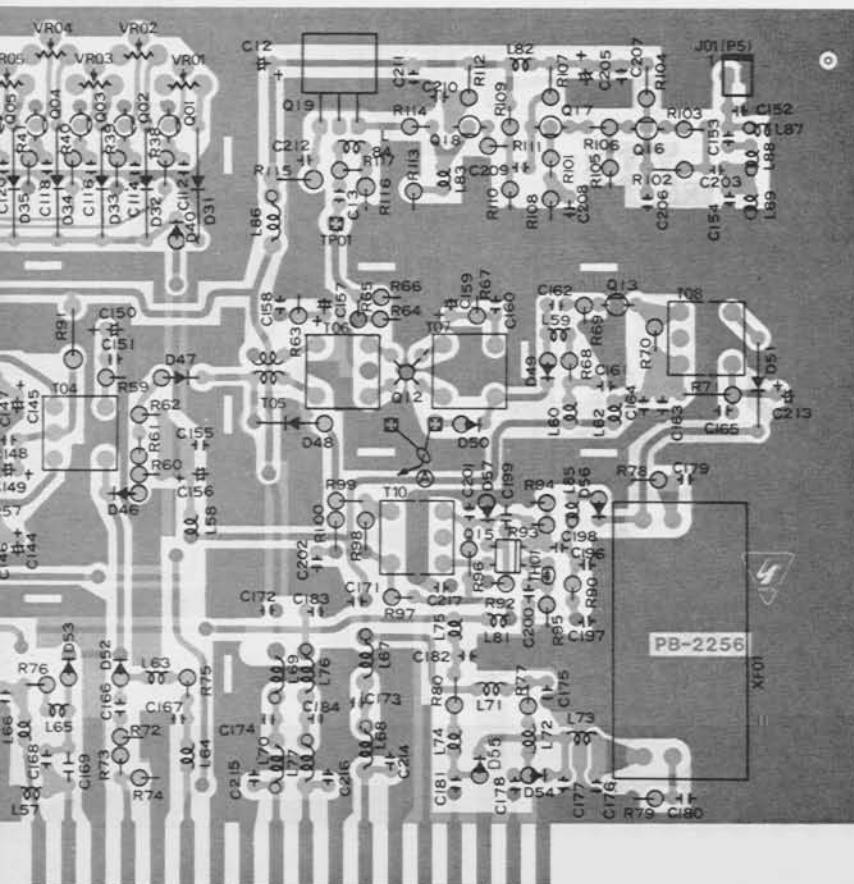

Viewed from solder side

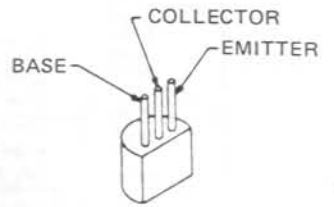

2SB774
2SC1923-O

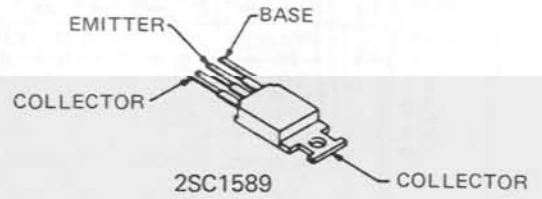

2SC1589

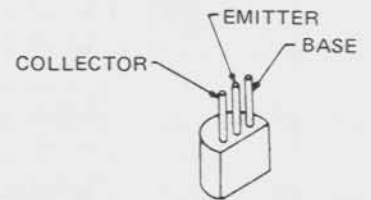

2SC2026
2SC2407

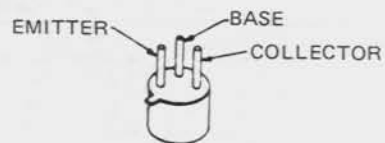

2N4427

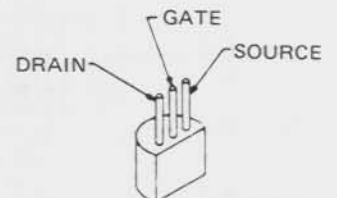

2SK125



3SK73GR

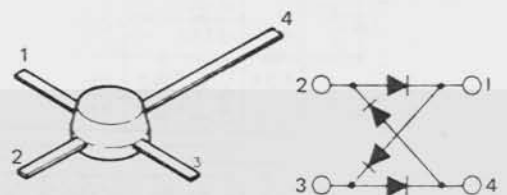

ND487C2-3R

RF UNIT VOLTAGE CHART

(DC VOLTS)

	E(S)	C(D)	B(G1)	G2	REMARKS
Q1001	8.3	7.6	8.3		TX 21 MHz
Q1002	8.4	7.7	8.4		TX 14.5 MHz
Q1003	8.5	7.8	8.4		TX 6 MHz
Q1004	8.5	7.6	8.4		TX 7.5 MHz
Q1005	8.4	7.7	8.4		TX 10.5 MHz
Q1006	8.5	7.7	8.4		TX 4.5 MHz
Q1007	8.5	7.7	8.4		TX 3.5 MHz
Q1008	8.5	7.8	8.4		TX 2.5 MHz
Q1009	8.4	7.7	8.4		TX 1.9 MHz
Q1010	0.05	12.3	2.7		
Q1011	0.05	12.3	2.7		
Q1013	1.6	13.3	0		RX
Q1014	1.6	13.1	2.3		TX
Q1015	2.1	8.9	2.1	2.7	TX
Q1016	0.4	3.1	1.1		
Q1017	1.1	8.9	1.9		
Q1018	4.9	11.5	5.7		
Q1019	4.0	9.5	4.8		

COMPONENT APPLICATIONS

Q1001	2SB774	Transistor	TX Power Controller	D1001	1SS53	Si Diode	Switch
Q1002	"	"	"				
Q1003	"	"	"				
Q1004	"	"	"				
Q1005	"	"	"	D1040	1SS53	Si Diode	Switch
Q1006	"	"	"	D1041	RD8.2EB3	Zener Diode	Regulator
Q1007	"	"	"	D1042	1SV70	PIN Diode	TX, RX, RF
Q1008	"	"	"				Attenuator
Q1009	"	"	"	D1043	"	"	"
Q1010	2N4427	"	TX, RX, RF Amplifier	D1044	"	"	"
Q1011	"	"	"	D1045	RD6.2EB3	Zener Diode	Regulator
Q1012	ND487C2-3R	IC (Ring Module)	RX 1st Mixer TX 2nd Mixer	D1046	1SS53	Si Diode	Switch
Q1013	2SK125-3	Junction FET	RX 1st IF Amplifier	D1047	"	"	"
Q1014	2SC2407	Transistor	TX Amplifier	D1048	"	"	"
Q1015	3SK73GR	Dual Gate MOS FET	TX ALC Amplifier	D1049	"	"	"
Q1016	2SC1923-O	Transistor	RX 1st LOCAL Buffer Amplifier TX 2nd LOCAL Buffer Amplifier	D1050	"	"	"
Q1017	2SC2026	"	RX 1st LOCAL Amplifier TX 2nd LOCAL Amplifier	D1051	"	"	"
Q1018	2SC2407	"	RX 1st LOCAL Buffer Amplifier TX 2nd LOCAL Buffer Amplifier	D1052	"	"	"
Q1019	2SC1589	"	"	D1053	"	"	"
				D1054	"	"	"
				D1055	"	"	"
				D1056	"	"	"
				D1057	RD9.1EB2	Zener Diode	Regulator
				XF1001	XF-73KX	Crystal Filter	RX 1st IF Filter TX 2nd IF Filter
				TH1001	D22A	Thermistor	Temperature Compensator

SENSOR UNIT PARTS LAYOUT

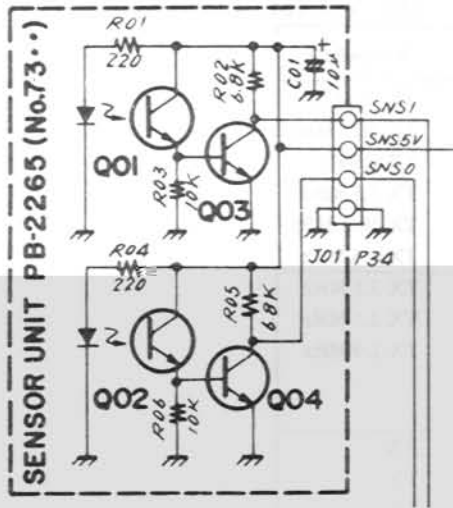

COMPONENT APPLICATIONS

Q7301	ON-1105	Photo Interrupter	Switch
Q7302	"	"	"
Q7303	2SC945AP	Transistor	DC Amplifier
Q7304	"	"	"

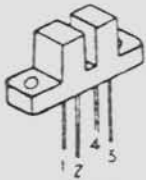

ON1105

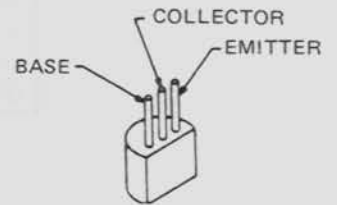
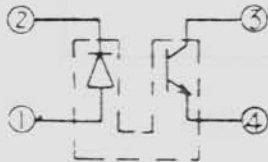

2SC945AP

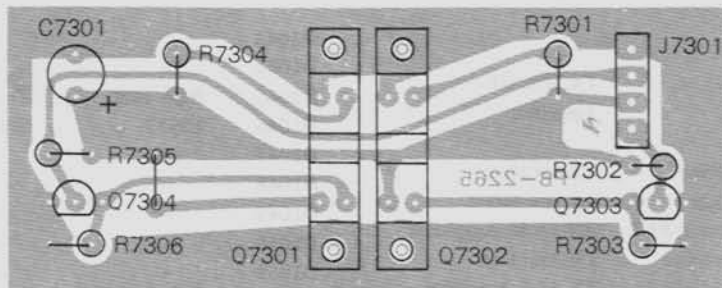

Viewed from component side

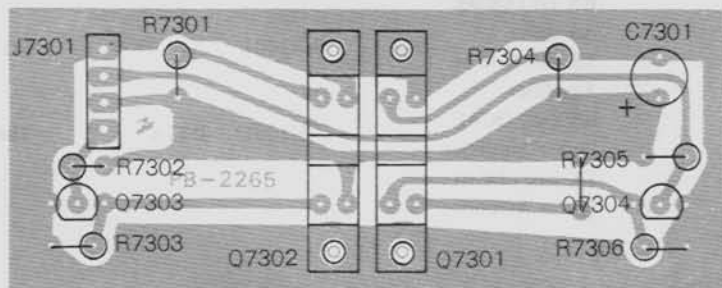

Viewed from solder side

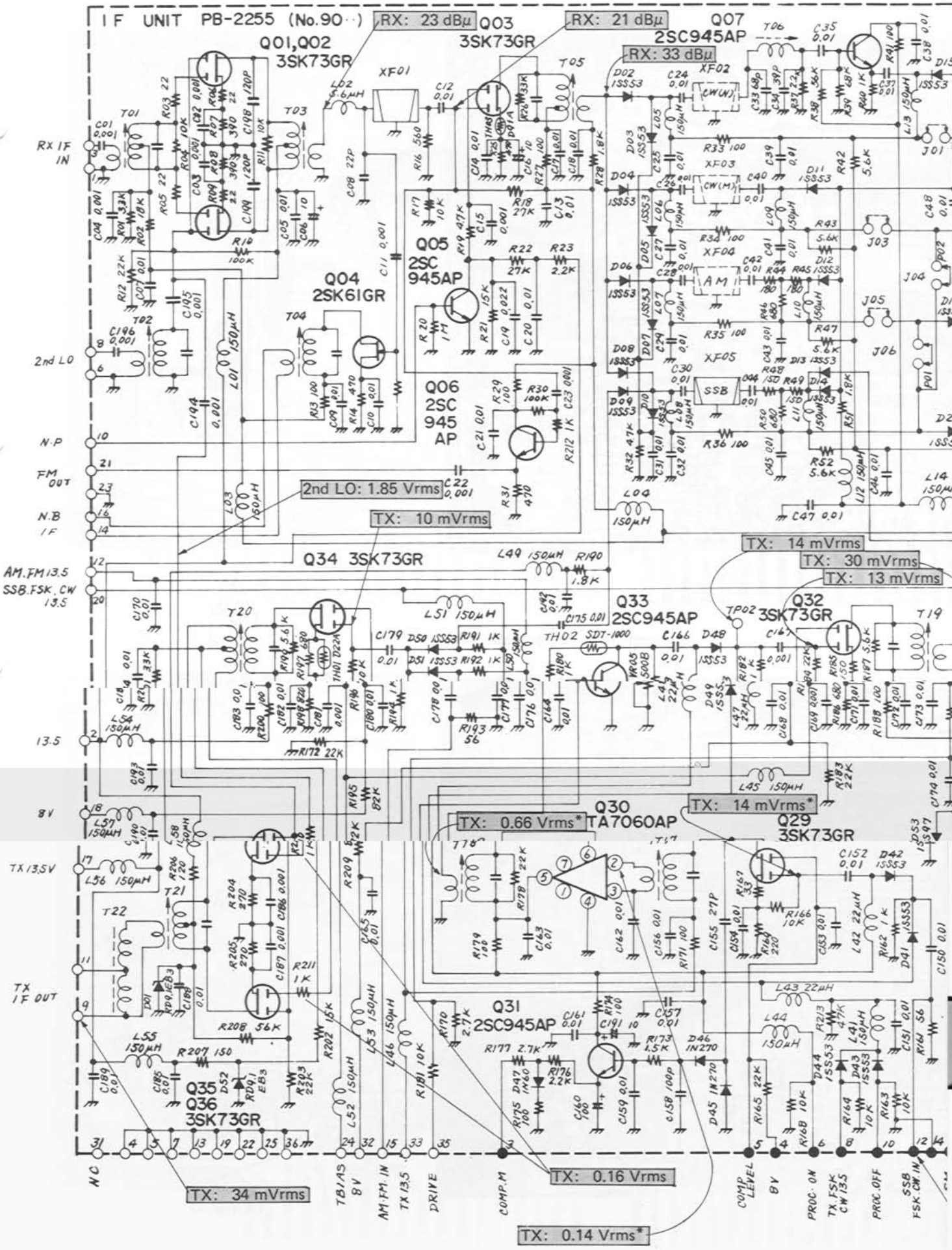

T (Early model)

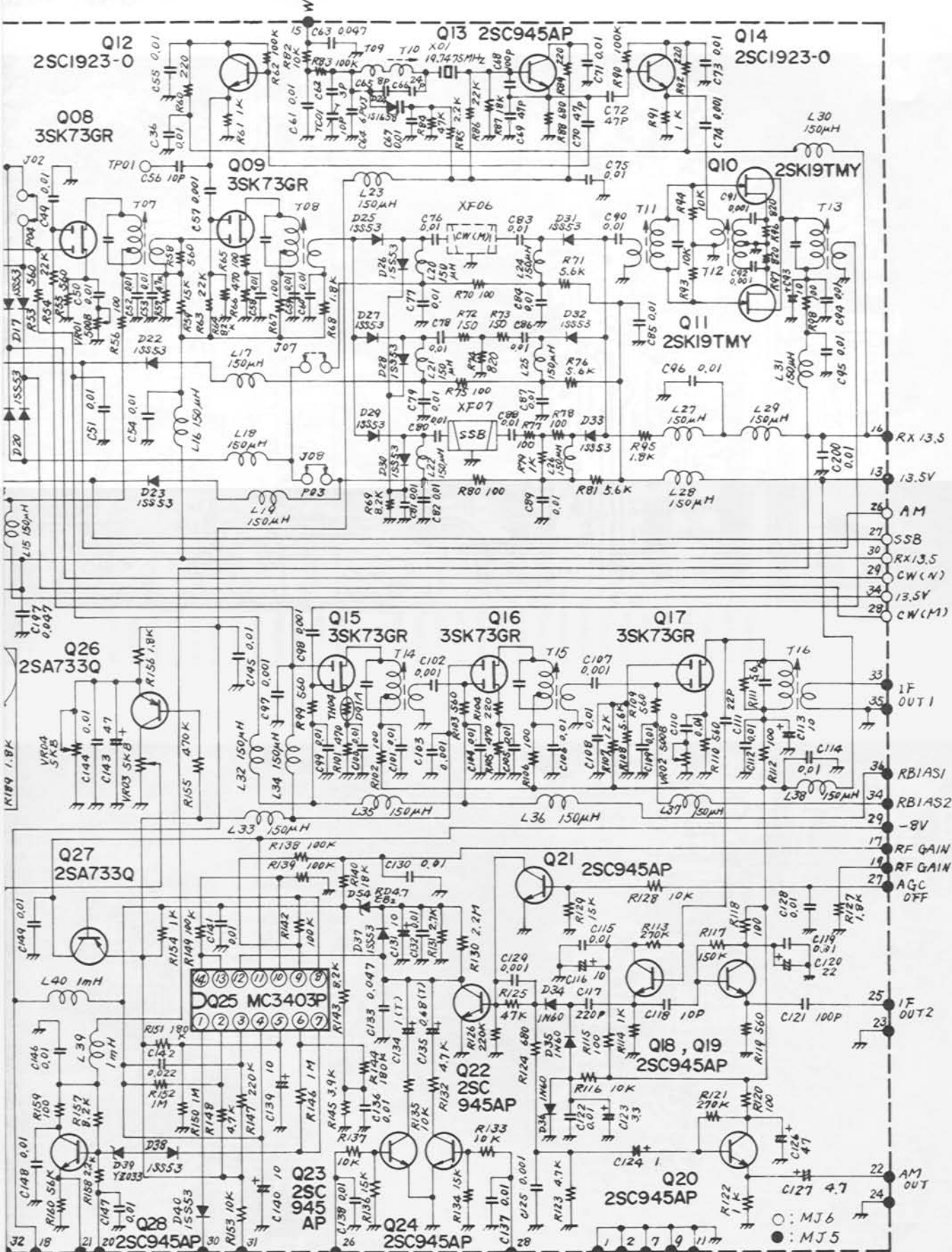

An asterisk (*) indicates signal level when using internal RF speech processor IF UNIT SIGNAL LEVELS

- TX: FREQUENCY; 14.2 MHz
- ANT OUTPUT; SSB 100 W, AM 25 W
- RX: FREQUENCY; 14.2 MHz
- ANT INPUT; 0 dBμ (1 μV)

TX: 15 mVrms

○: MJ6
●: MJ5

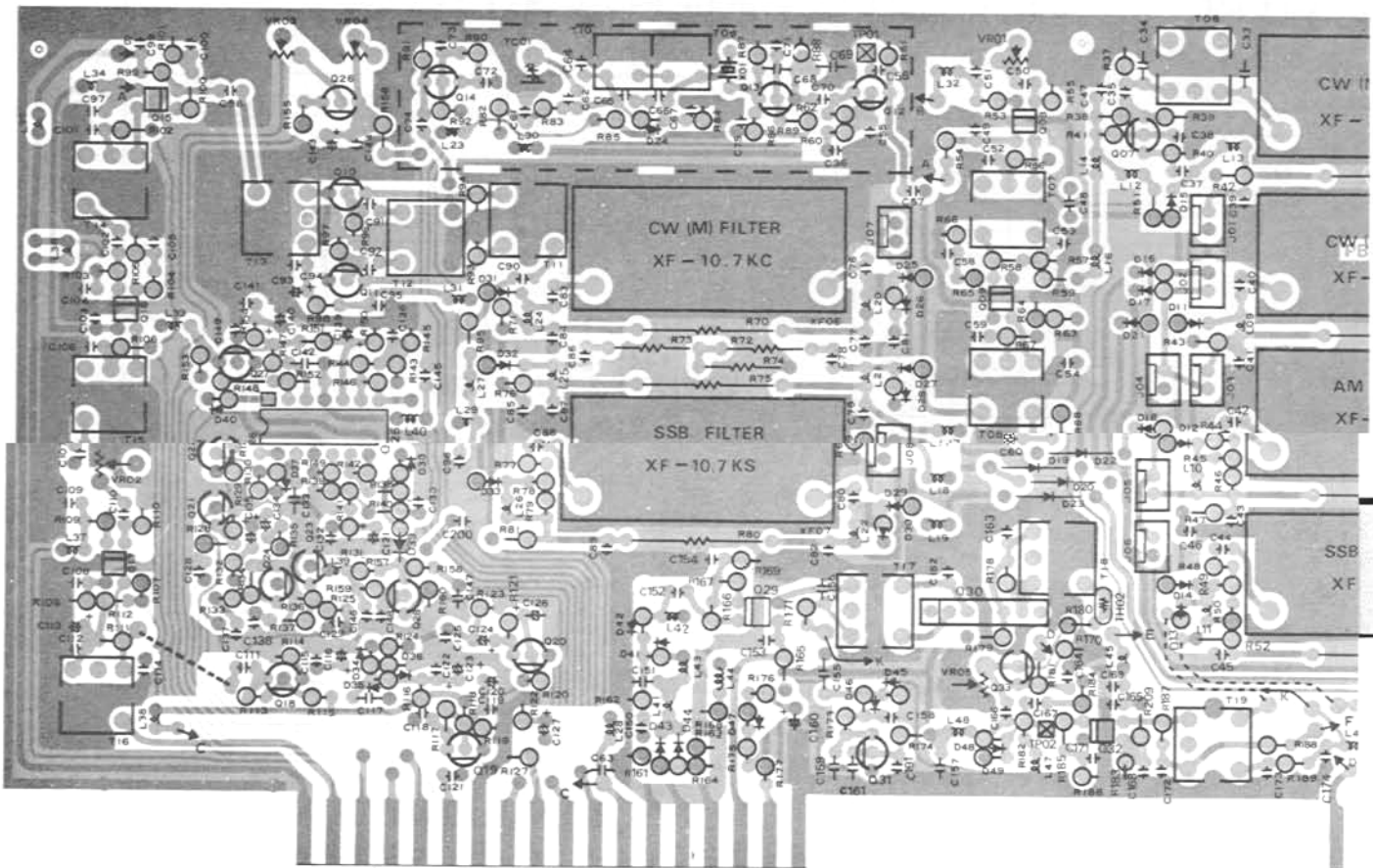
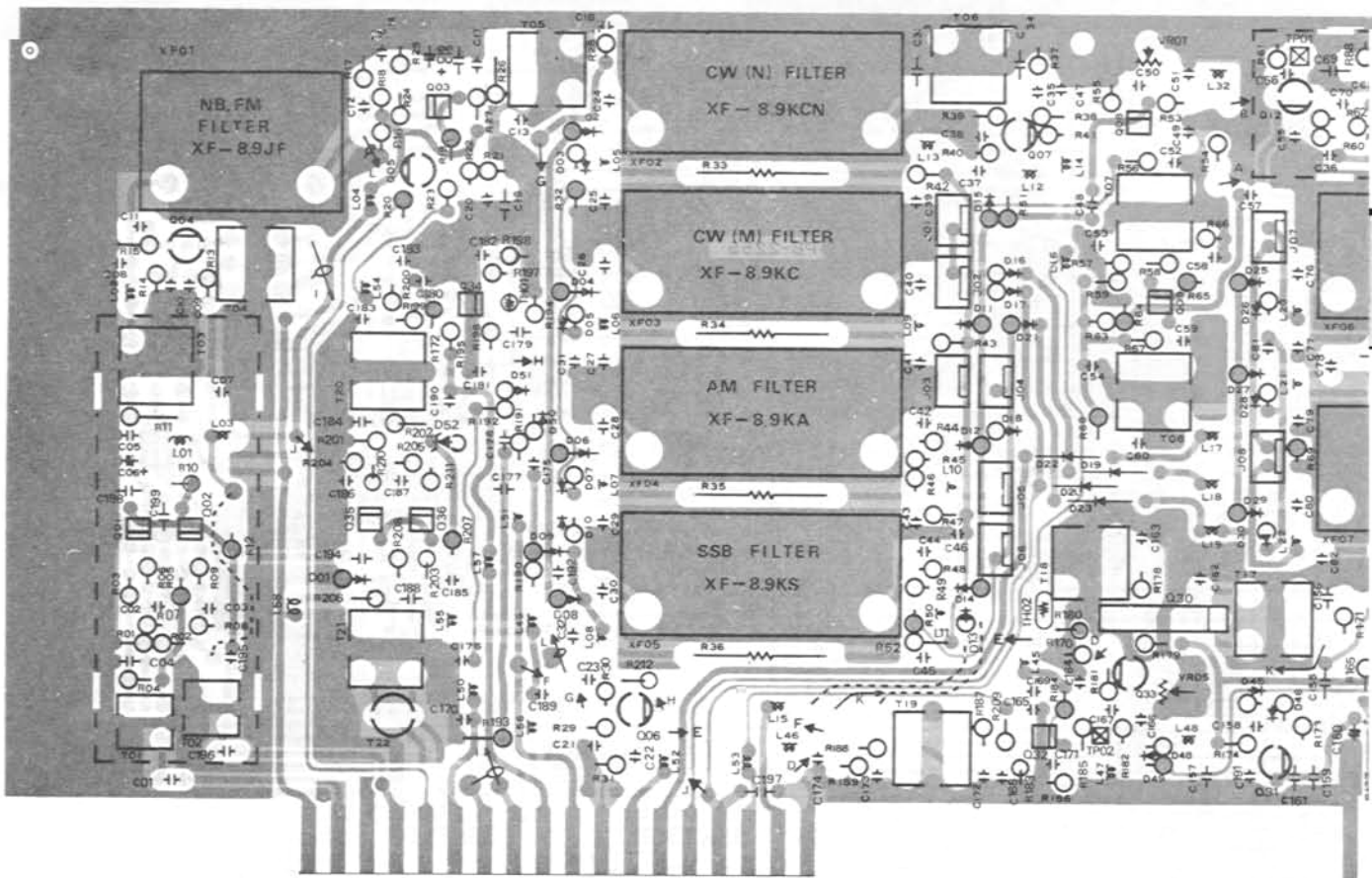

RTS LAYOUT (Early model)

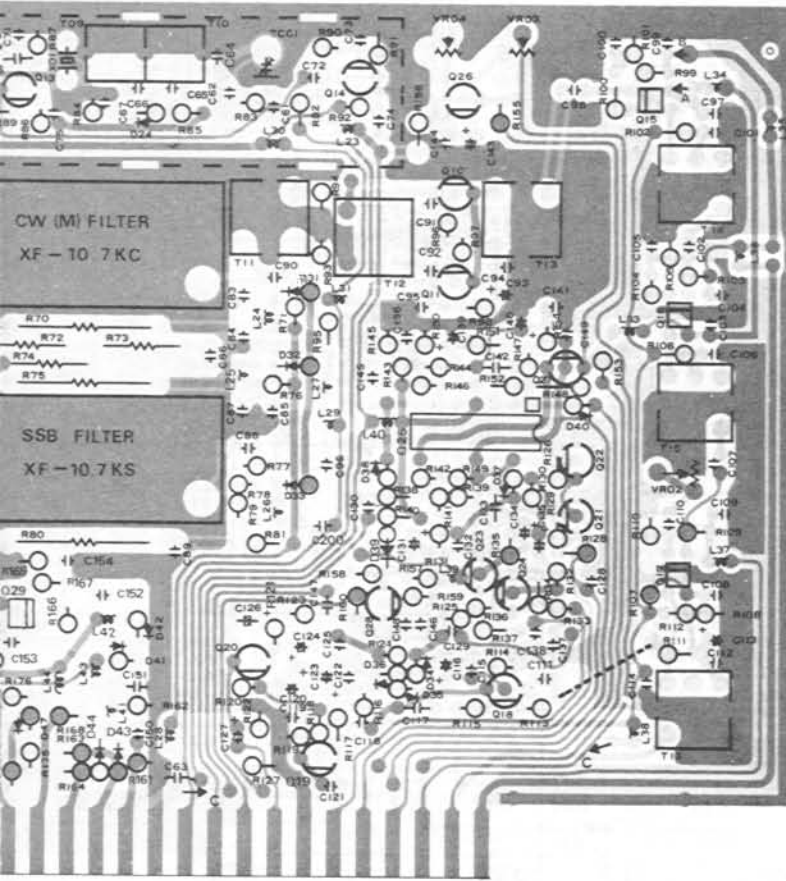

Viewed from component side

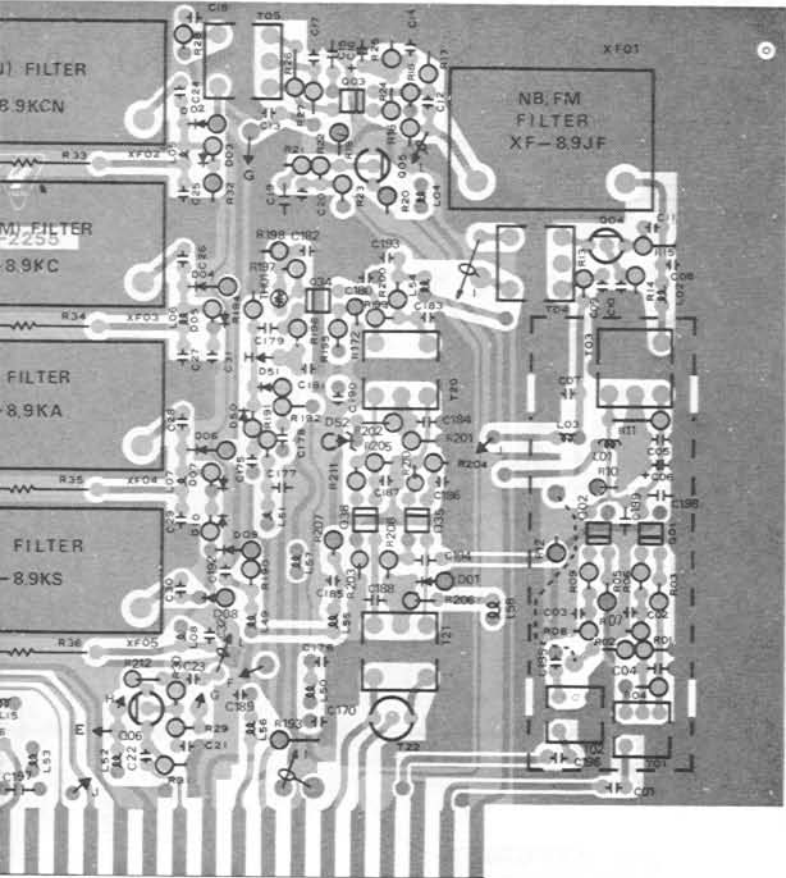

Viewed from solder side

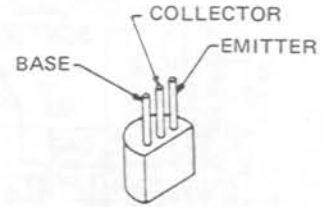

2SA733AQ
2SC1923-O
2SC945AP

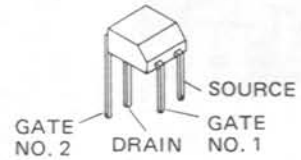

3SK73GR

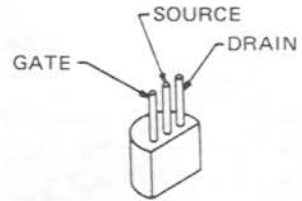

2SK19TMY
2SK61GR

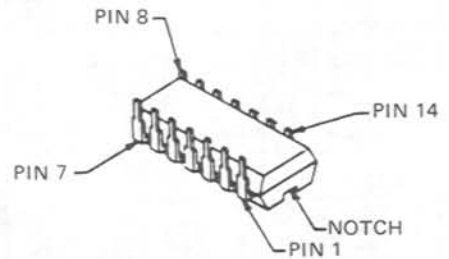

MC3403P

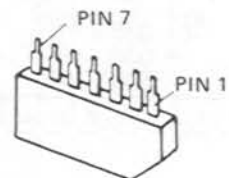

TA7060AP

IF UNIT PB-2255 (No.90)

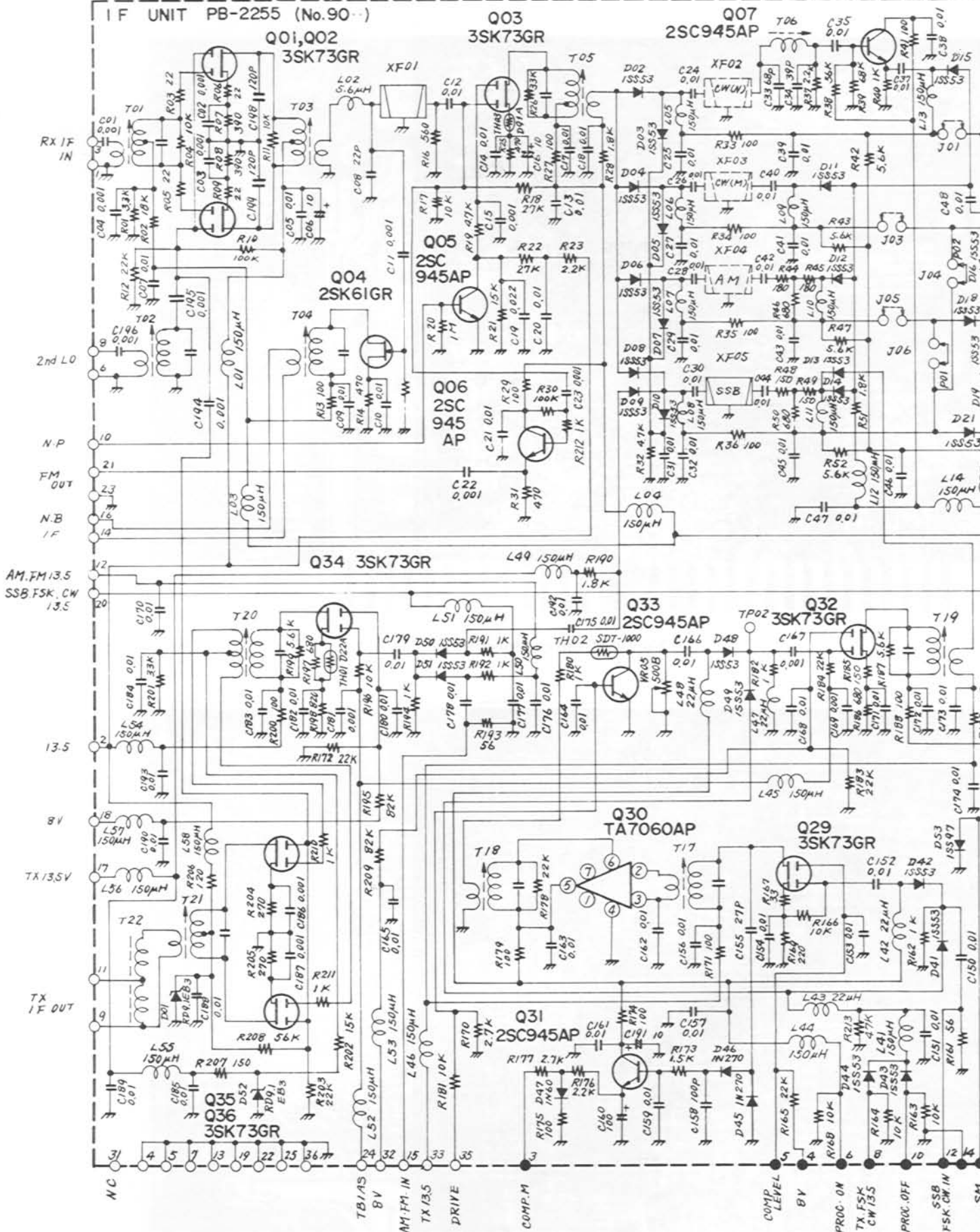

(After prod 6)

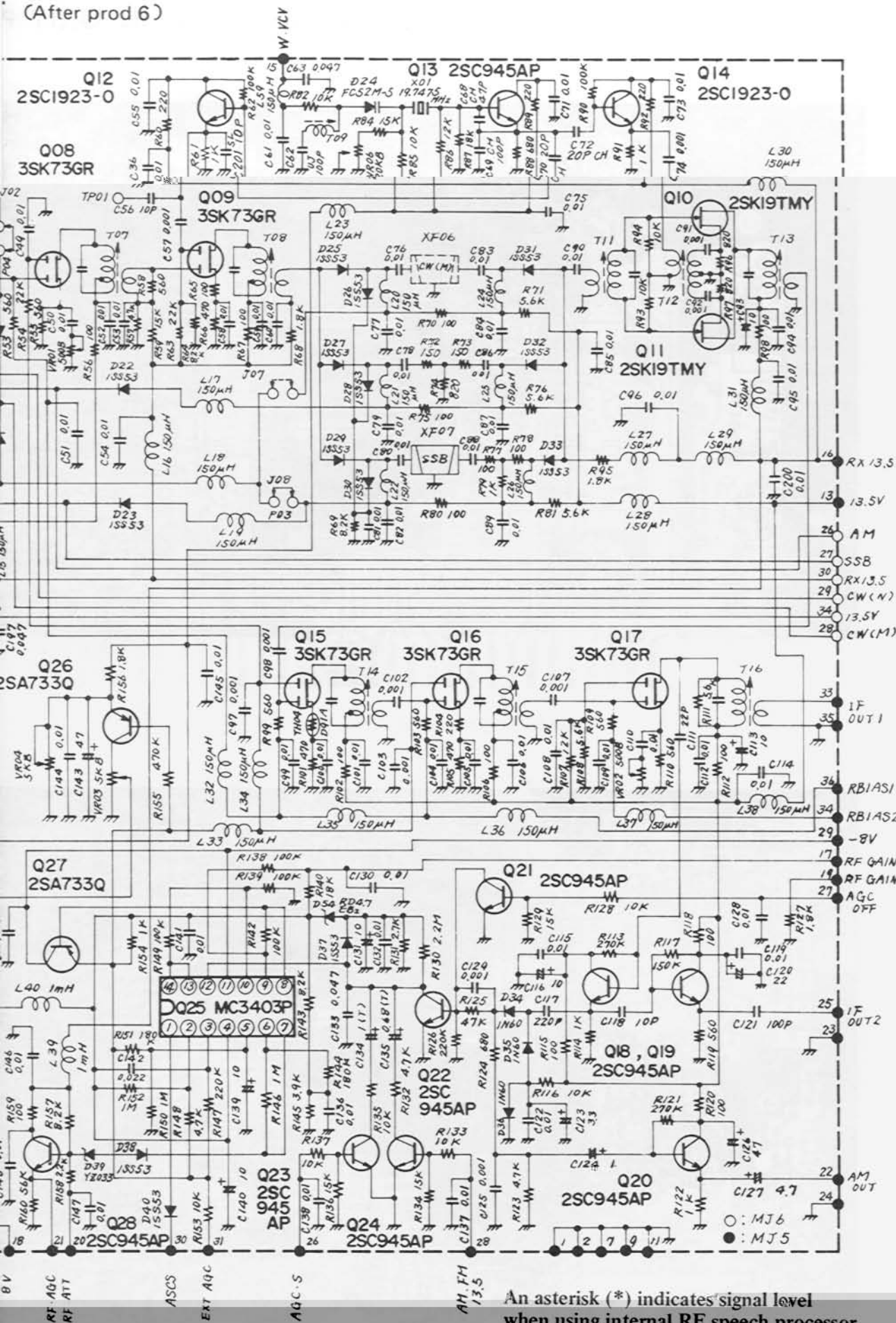

An asterisk (*) indicates signal level when using internal RF speech processor IF UNIT SIGNAL LEVELS

- TX: FREQUENCY; 14.2 MHz
- ANT OUTPUT; SSB 100 W, AM 25 W
- RX: FREQUENCY; 14.2 MHz
- ANT INPUT; 0 dBμ (1 μV)

ARTS LAYOUT (After prod 6)

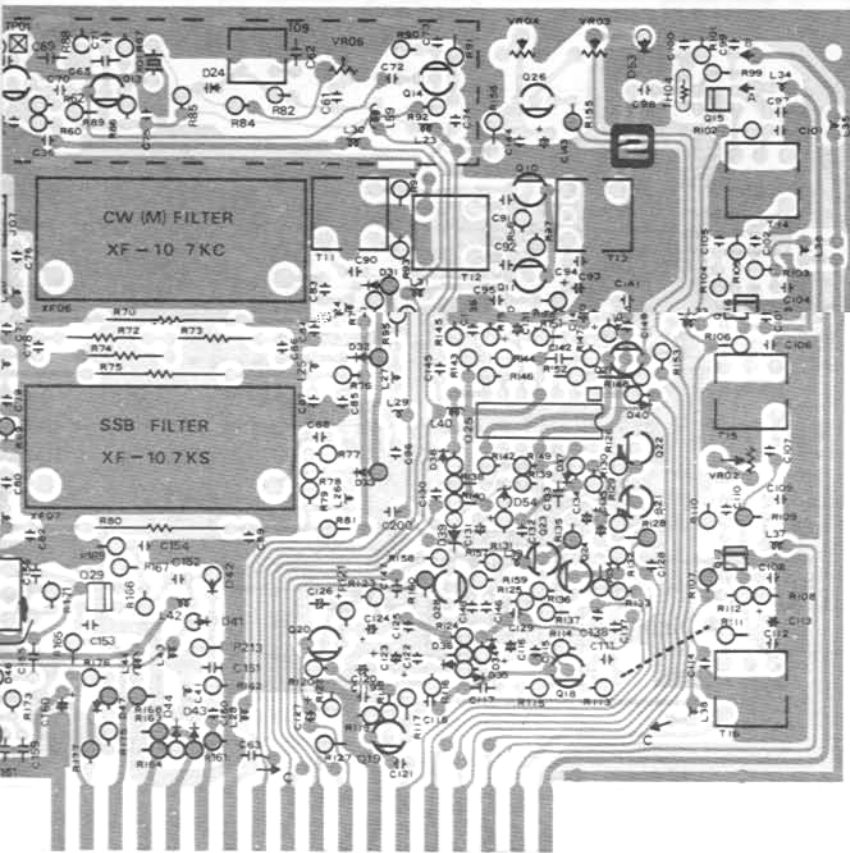

Viewed from component side

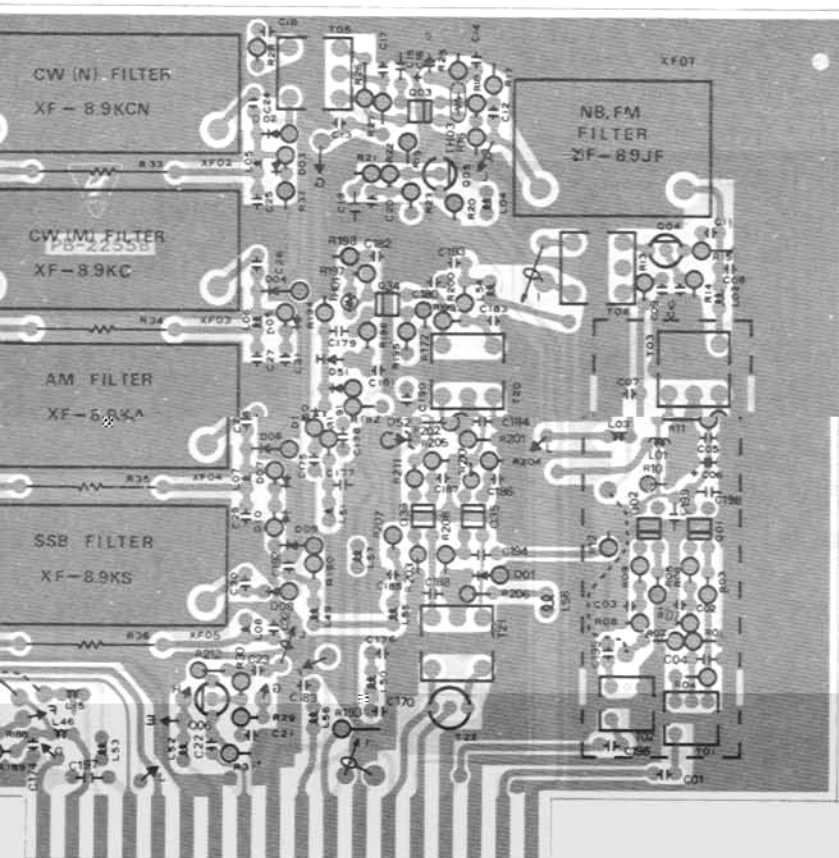

Viewed from solder side

IF UNIT VOLTAGE CHART

(DC VOLTS)

	E(S)	C(D)	B(G1)	G2	REMARKS
Q9001	1.9	13.5	2.1	2.5	RX
Q9002	1.9	13.5	2.1	2.5	RX
Q9003	3.5	12.8	3.4	4.6	RX
Q9004	0.7	13.3	0		RX
Q9005	0	4.9	0		NB OFF
Q9006	6.6	12.0	7.2		RX
Q9007	6.1	12.8	6.7		RX
Q9008	3.0	12.9	2.9	3.9	
Q9009	3.2	12.9	2.9	3.7	RX
Q9010	1.3	13.2	0		RX
Q9011	1.3	13.2	0		RX
Q9012	5.6	12.2	6.4		RX
Q9013	3.1	7.2	3.5		
Q9014	5.3	12.3	6.0		RX
Q9015	3.0	12.9	2.9	3.9	
Q9016	3.0	12.9	2.9	3.9	
Q9017	2.7	12.9	2.7	4.2	
Q9018	6.3	12.8	6.9		
Q9019	6.3	12.3	5.6		
Q9020	6.4	12.8	7.0		
Q9021	0/0	0.1/0	0/0.7		AGC ON/OFF
Q9022	0/0	0/3.4	0.1/0		AGC ON/OFF
Q9023	0	0	0.7		AGC S
Q9024	0	0	0.7		AM, FM
Q9026	0	4.3	3.9		AGC OFF
Q9027	3.9	-8.1	3.3		
Q9028	3.9	12.4	7.1		
Q9029	0.9	12.9	0.8	2.6	PROC ON
Q9031	0	13.4	0		PROC ON
Q9032	1.3	12.6	0.8	1.7	SSB, FSK, CW
Q9033	0	0	6.1		DRIVE VR CCW
Q9034	1.2	13.3	0.8	1.8	SSB, FSK, CW
Q9035	1.7	9.3	1.7	2.6	TX
Q9036	1.7	9.3	1.7	2.6	TX

	1	2	3	4	5	6	7	8	9	10	11	12	13	14	REMARKS
Q9025	-7.7	4.0	3.9	8.2	3.4	3.2	6.9	3.3	2.0	2.0	-8.1	3.4	4.1	4.1	
Q9030	-	1.5	1.5	0	12.6	12.6	-								PROC ON

SERVICING

IF UNIT COMPONENT APPLICATIONS

Q9001	3SK73GR	Dual Gate MOS FET	RX 2nd Mixer	D9012	"	"	"
Q9002	"	"	"	D9013	"	"	"
Q9003	"	"	RX NB Gate	D9014	"	"	"
Q9004	2SK61GR	Junction FET	RX NB Amplifier	D9015	"	"	"
Q9005	2SC945AP	Transistor	RX NB Controller	D9016	"	"	"
Q9006	"	"	RX FM Buffer Amplifier	D9017	"	"	"
Q9007	"	"	RX CW(N) Buffer Amplifier	D9018	"	"	"
Q9008	3SK73GR	Dual Gate MOS FET	RX 2nd IF Amplifier	D9019	"	"	"
Q9009	"	"	RX Width First Mixer	D9020	"	"	"
Q9010	2SK19TMY	Junction FET	RX Width Second Mixer	D9021	"	"	"
Q9011	"	"	"	D9022	"	"	"
Q9012	2SC1923-O	Transistor	RX Width Buffer Amplifier	D9023	1SS53	Si Diode	Switch
Q9013	2SC945AP	"	RX Width VCXO	D9024	1S1658	Varactor Diode	RX Width VCXO
Q9014	2SC1923-O	"	RX Width Buffer Amplifier	D9025	1SS53	Si Diode	Switch
Q9015	3SK73GR	Dual Gate MOS FET	RX 2nd IF Amplifier	D9026	"	"	"
Q9016	"	"	"	D9027	"	"	"
Q9017	"	"	"	D9028	"	"	"
Q9018	2SC945AP	Transistor	RX Buffer Amplifier	D9029	"	"	"
Q9019	"	"	"	D9030	"	"	"
Q9020	"	"	RX AM AF Amplifier	D9031	"	"	"
Q9021	"	"	RX AGC OFF Switch	D9032	"	"	"
Q9022	"	"	RX AGC Amplifier	D9033	"	"	"
Q9023	"	"	RX AGC Switch	D9034	1N60	Ge Diode	RX AM Detector
Q9024	"	"	"	D9035	"	"	"
Q9025	MC3403P	IC	RX AGC DC Amplifier	D9036	"	"	Temperature Compensator
Q9026	2SA733Q	Transistor	RX S-Meter Amplifier	D9037	1SS53	Si Diode	Discharge Diode
Q9027	"	"	RX IF AGC Buffer Amplifier	D9038	"	"	Switch
Q9028	2SC945AP	"	RX RF AGC Amplifier	D9039	YZ033	Zener Diode	Regulator
Q9029	3SK73GR	Dual Gate MOS FET	TX IF Amplifier	D9040	1SS53	Si Diode	Switch
Q9030	TA7060AP	IC	TX RF Speech Processor Amplifier	D9041	"	"	"
Q9031	2SC945AP	Transistor	TX COMP. M Driver Amplifier	D9042	"	"	"
Q9032	3SK73GR	Dual Gate MOS FET	TX IF Amplifier	D9043	"	"	"
Q9033	2SC945AP	Transistor	TX Driver Controller	D9044	1SS53	Si Diode	Switch
Q9034	3SK73GR	Dual Gate MOS FET	TX IF Amplifier	D9045	1N60	Ge Diode	COMP. M Detector
Q9035	"	"	TX 1st Mixer	D9046	"	"	"
Q9036	"	"	"	D9047	"	"	Logarithmic Compensator
D9001	RD9.1EB3	Zener Diode	Regulator	D9048	1SS53	Si Diode	Switch
D9002	1SS53	Si Diode	Switch	D9049	"	"	"
D9003	"	"	"	D9050	"	"	"
D9004	"	"	"	D9051	"	"	"
D9005	"	"	"	D9052	RD9.1EB3	Zener Diode	Regulator
D9006	"	"	"	X9001	19.7475MHz	Crystal	RX Width VCXO
D9007	"	"	"	XF9001	XF-8.9JF	Crystal Filter	RX 2nd IF Filter (for NB, FM)
D9008	"	"	"	XF9002	XF-8.9KCN	"	RX 3rd IF Filter (for CW(N), Option)
D9009	"	"	"	XF9003	XF-8.9KC	"	"
D9010	"	"	"	XF9004	XF-8.9KA	"	(for CW(M), Option)
D9011	"	"	"	XF9005	XF-8.9KS	"	"
D9012	"	"	"	XF9006	XF-10.7KC	"	(for SSB) RX Width Filter
D9013	"	"	"	XF9007	XF-10.7KS	"	(for CW(M), Option)
D9014	"	"	"	TH9001	D22A	Thermistor	"
D9015	"	"	"	TH9002	SDT-1000	"	Temperature Compensator
D9016	"	"	"				"
D9017	"	"	"				"
D9018	"	"	"				"
D9019	"	"	"				"
D9020	"	"	"				"
D9021	"	"	"				"
D9022	"	"	"				"
D9023	"	"	"				"
D9024	"	"	"				"
D9025	"	"	"				"
D9026	"	"	"				"
D9027	"	"	"				"
D9028	"	"	"				"
D9029	"	"	"				"
D9030	"	"	"				"
D9031	"	"	"				"
D9032	"	"	"				"
D9033	"	"	"				"
D9034	"	"	"				"
D9035	"	"	"				"
D9036	"	"	"				"
D9037	"	"	"				"
D9038	"	"	"				"
D9039	"	"	"				"
D9040	"	"	"				"
D9041	"	"	"				"
D9042	"	"	"				"
D9043	"	"	"				"
D9044	"	"	"				"
D9045	"	"	"				"
D9046	"	"	"				"
D9047	"	"	"				"
D9048	"	"	"				"
D9049	"	"	"				"
D9050	"	"	"				"
D9051	"	"	"				"
D9052	"	"	"				"

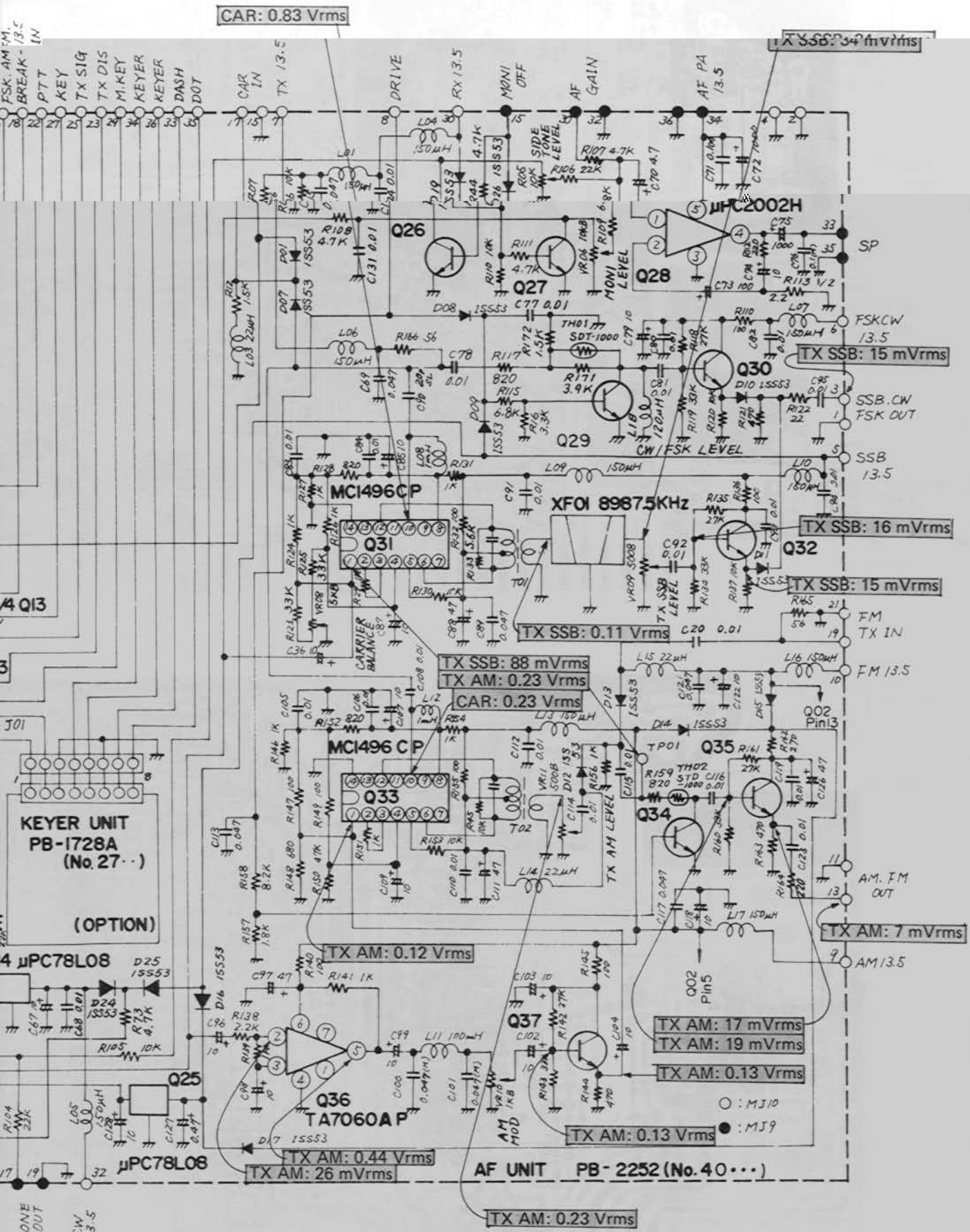

AF UNIT SIGNAL LEVELS

- TX: FREQUENCY; 14.2 MHz
- ANT OUTPUT; SSB 100 W, AM 25 W
- RX: FREQUENCY; 14.2 MHz
- ANT INPUT; 0 dBμ (1 μV)

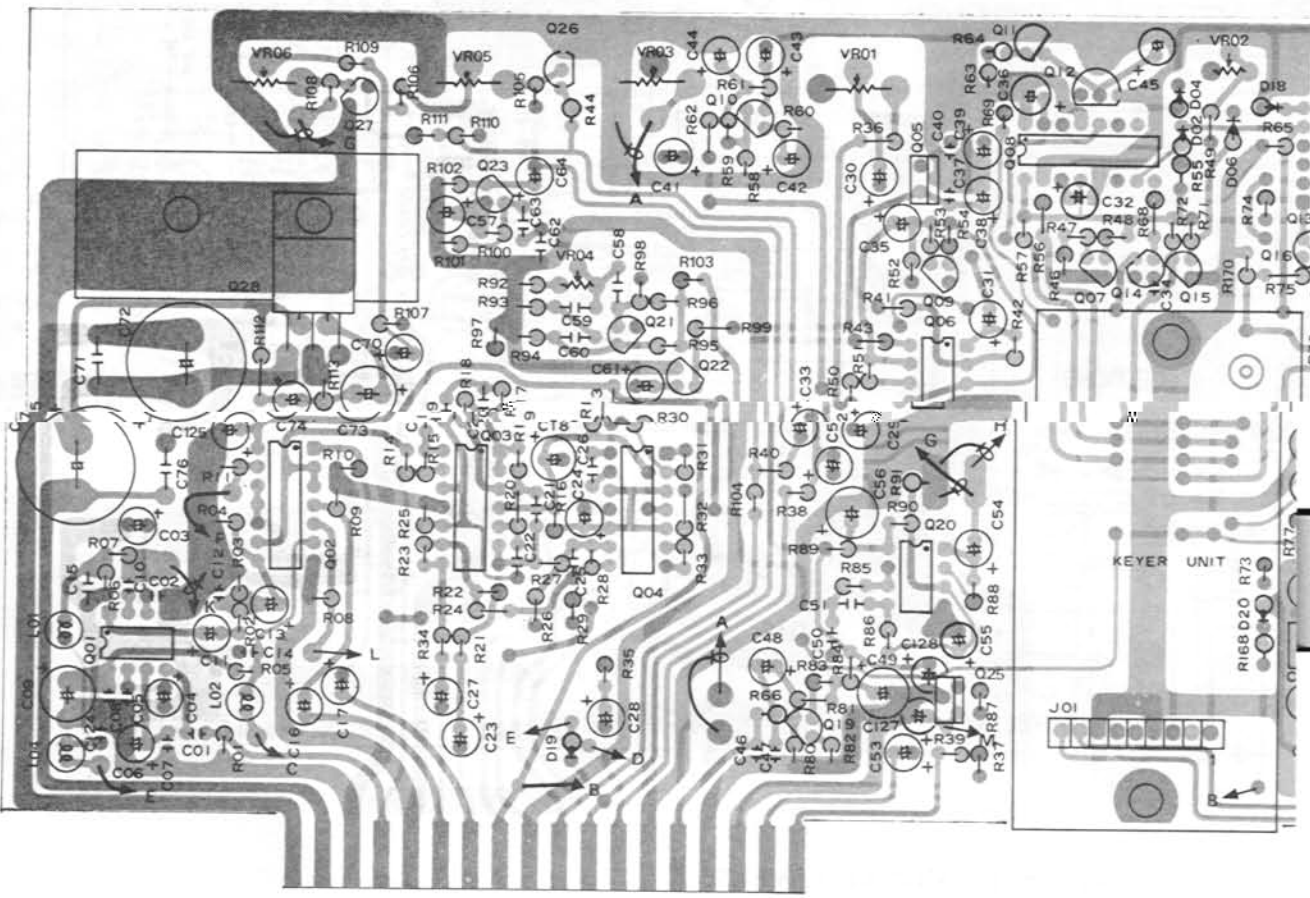
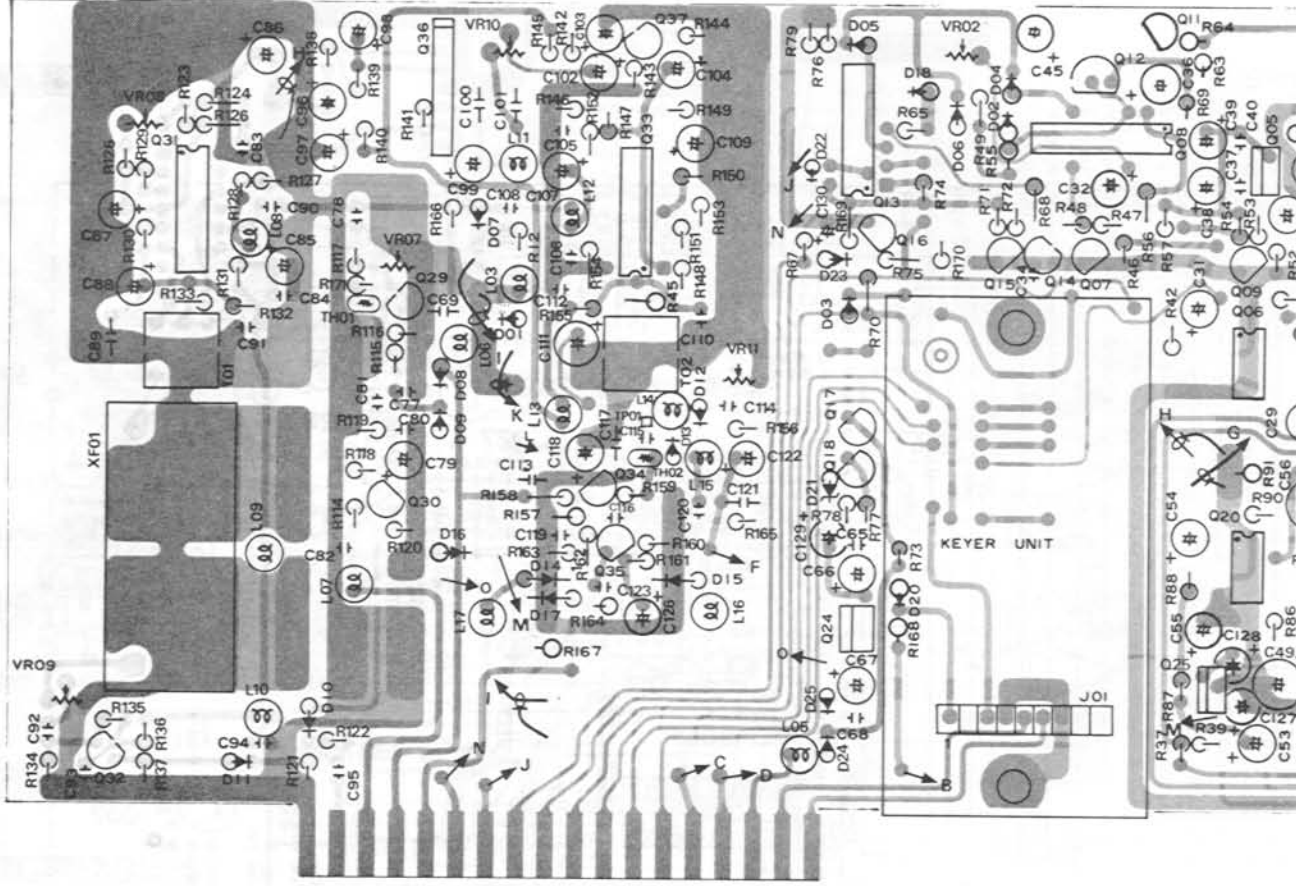

AF UNIT VOLTAGE CHART

(DC VOLTS)

	1	2	3	4	5	6	7	8	9	10	11	12	13	14	REMARKS
Q4001	9.2	5.5	3.8	0	3.8	5.6	5.6	11.2							SSB, CW, FSK
Q4002	0	6.2	6.2	0	0	12.8	0	6.2	6.2	0	0	0	0	13.5	
Q4003	6.6	6.6	6.5	13.1	6.6	6.6	6.6	6.6	6.6	6.6	0	6.6	6.6	7.9	
Q4004	6.6	6.6	6.6	13.1	6.6	6.6	6.6	6.6	6.6	6.6	0	6.6	6.6	6.6	
Q4006	4.9	5.0	5.0	0	5.0	5.0	4.9	13.2							SSB, AM, FM
Q4020	3.8	3.8	3.8	0	3.8	3.8	3.8	7.6							
Q4028	0.7	0.7	0	6.6	13.6										
Q4036	-	1.5	1.5	0	9.8	12.5	-								

	E	C	B	REMARKS
Q4007	0	5.0	0	
Q4009	0	5.0	0	
Q4010	0.4	4.7	1.0	SSB, AM, FM
Q4019	0.2	4.9	0.8	SSB, AM, FM
Q4023	3.0	7.2	3.6	CW
Q4026	0	0	0.7	
Q4027	0	0	0.7	
Q4029	0/0	0/0	6.3/0	DRIVE VR CCW/CW
Q4030	5.6	12.4	6.3	CW, FSK
Q4032	5.6	12.4	6.2	SSB
Q4034	0/0	0/0	5.9/0	DRIVE VR CCW/CW
Q4035	4.4	10.0	5.0	AM, FM
Q4037	5.4	6.1	12.2	AM

	IN	OUT	REMARKS
Q4005	13.5	5.0	
Q4024	13.5	8.1	CW
Q4025	12.7	8.1	SSB, AM, FM

COMPONENT APPLICATIONS

Q4001	SN16913P	IC	RX Balanced Demodulator
Q4002	MC14016BCP	"	RX Mode Selector
Q4003	MC3403P	"	RX AF Amplifier, Active LPF, HPF
Q4004	"	"	RX APF Amplifier, Notch Filter
Q4005	μPC78L05	"	Regulator
Q4006	AN6552	"	TX VOX Amplifier, AMGC, Amplifier
Q4007	2SC945AP	Transistor	TX AMGC Switch
Q4008	MC14538BCP	IC	TX AMGC, VOX Switch
Q4009	2SC945AP	Transistor	TX VOX Switch
Q4010	"	"	TX ANTI-TRIP Amplifier
Q4011	"	"	TX ANTI-TRIP Switch
Q4012	"	"	TX BREAK-IN Switch
Q4013	MC14081BCP	IC	TX Gate
Q4014	2SC945AP	Transistor	TX AMGC Switch
Q4015	"	"	PPT Switch
Q4016	"	"	TX Keying
Q4017	"	"	"
Q4018	"	"	"
Q4019	2SC732TMGR	"	TX MIC Amplifier
Q4020	AN6552	IC	TX AF Active HPF
			TX AF Buffer Amplifier
Q4021	2SC945AP	Transistor	TX Sidetone Oscillator
Q4022	"	"	TX Sidetone Switch
Q4023	"	"	TX Sidetone Buffer Amplifier

Q4024	μPC78L08	IC	Regulator
Q4025	"	"	"
Q4026	2SC945AP	Transistor	TX Sidetone Switch
Q4027	"	"	TX Monitor Switch
Q4028	μPC2002H	IC	RX Audio Amplifier
Q4029	2SC945AP	Transistor	TX CW Driver Controller
Q4030	"	"	TX CW Driver Buffer Amplifier
Q4031	MC1496CP	IC	TX Balanced Modulator
Q4032	2SC945AP	Transistor	TX Buffer Amplifier
Q4033	MC1496CP	IC	TX AM Modulator
Q4034	2SC945AP	Transistor	TX Drive Controller
Q4035	"	"	TX Buffer Amplifier
Q4036	TA7060AP	IC	TX AF Limiter Amplifier
Q4037	2SC945AP	Transistor	TX AF Buffer Amplifier
D4001	1SS53	Si Diode	Switch
D4002	"	"	"
D4003	"	"	"
D4004	"	"	"
D4005	1SS53	Si Diode	Switch
D4006	1N60	Ge Diode	"
D4007	1SS53	Si Diode	"
D4016	"	"	"
D4018	RD5.1EB2	Zener Diode	Regulator
D4019	1SS53	Si Diode	Switch
D4020	RD8.2EB3	Zener Diode	Regulator
D4021	RD4.7EB2	"	Switch
D4022	1SS53	Si Diode	"
D4023	"	"	"
D4024	"	"	"
D4025	"	"	"
D4026	"	"	"
XF4001	XF-8.9KP	Crystal Filter	TX SSB Filter
TH4001	SDT-1000	Thermistor	Temperature Compensator
TH4002	"	"	"

KEYER UNIT PARTS LAYOUT

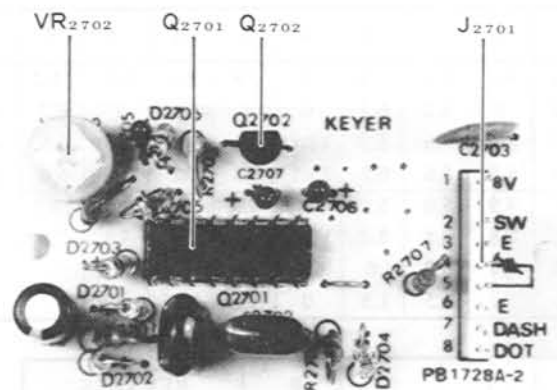
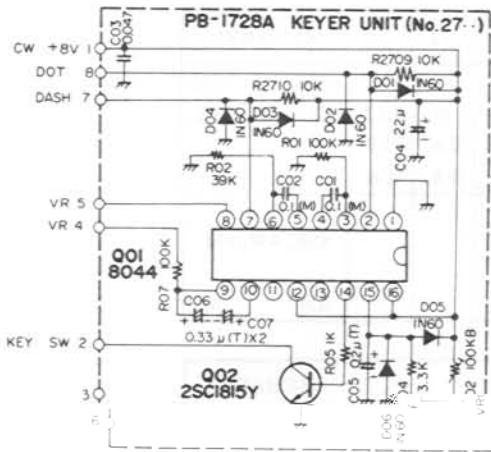

COMPONENT APPLICATIONS

Q2701	8044	IC	Electronic Keyer Utility IC
Q2702	2SC1815Y	Transistor	Switch
D2701	1N60	Ge Diode	Switch
D2706	"	"	"

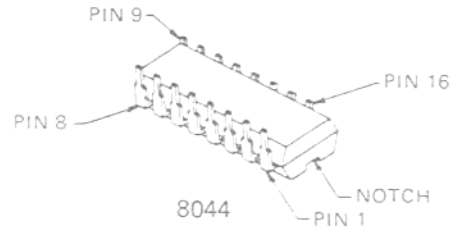

VOLTAGE CHART

(DC VOLTS)

	E	C	B	REMARKS
Q2702	0/0	7.7	0.4-0.9/0	CW MODE KEYER ON

	1	2	3	4	5	6	7	8	9	10
Q2701	0/0	0/8.2	8.1/0	8.2/0	8.2/0	8.1/0	0/8.2	4-5/0	4-5/1.7	4-5/8.2
	11	12	13	14	15	16	REMARKS			
	1-5/8.2	8.2/8.2	4-8/0	3-5/0	2-5/8.2	8.2/8.2	CW MODE, KEYER ON			

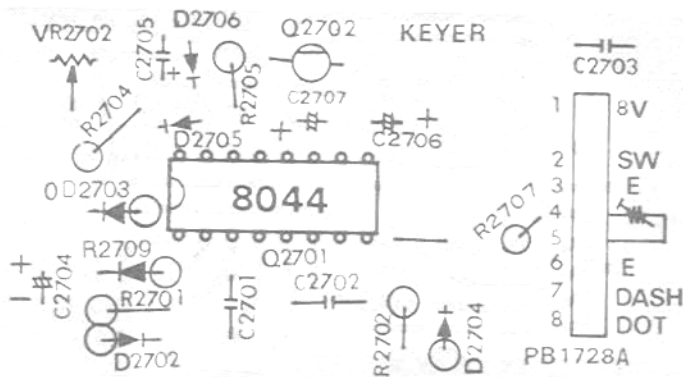

Viewed from component side

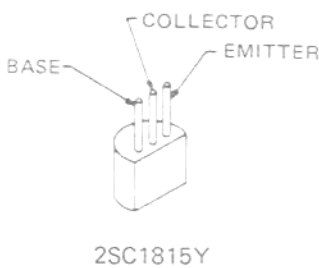

2SC1815Y

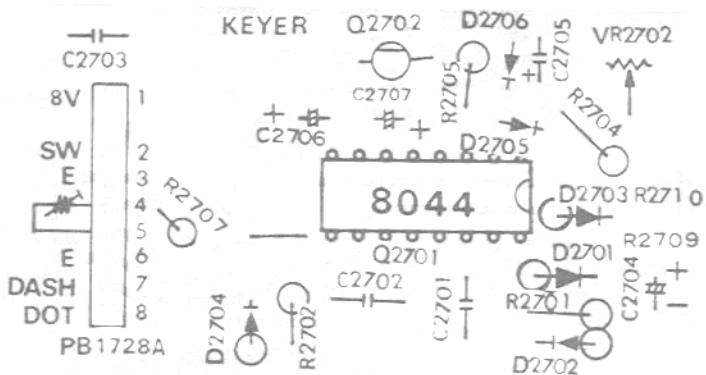

Viewed from foil side

(Early model)

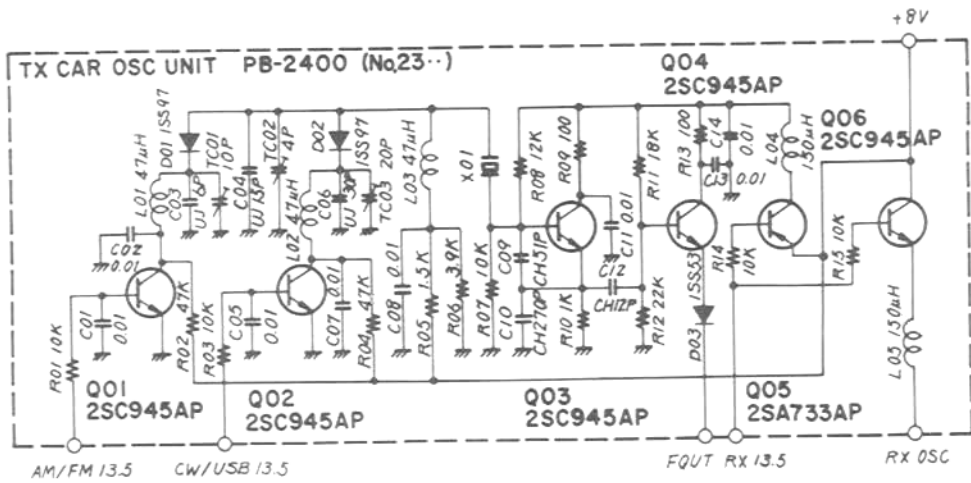
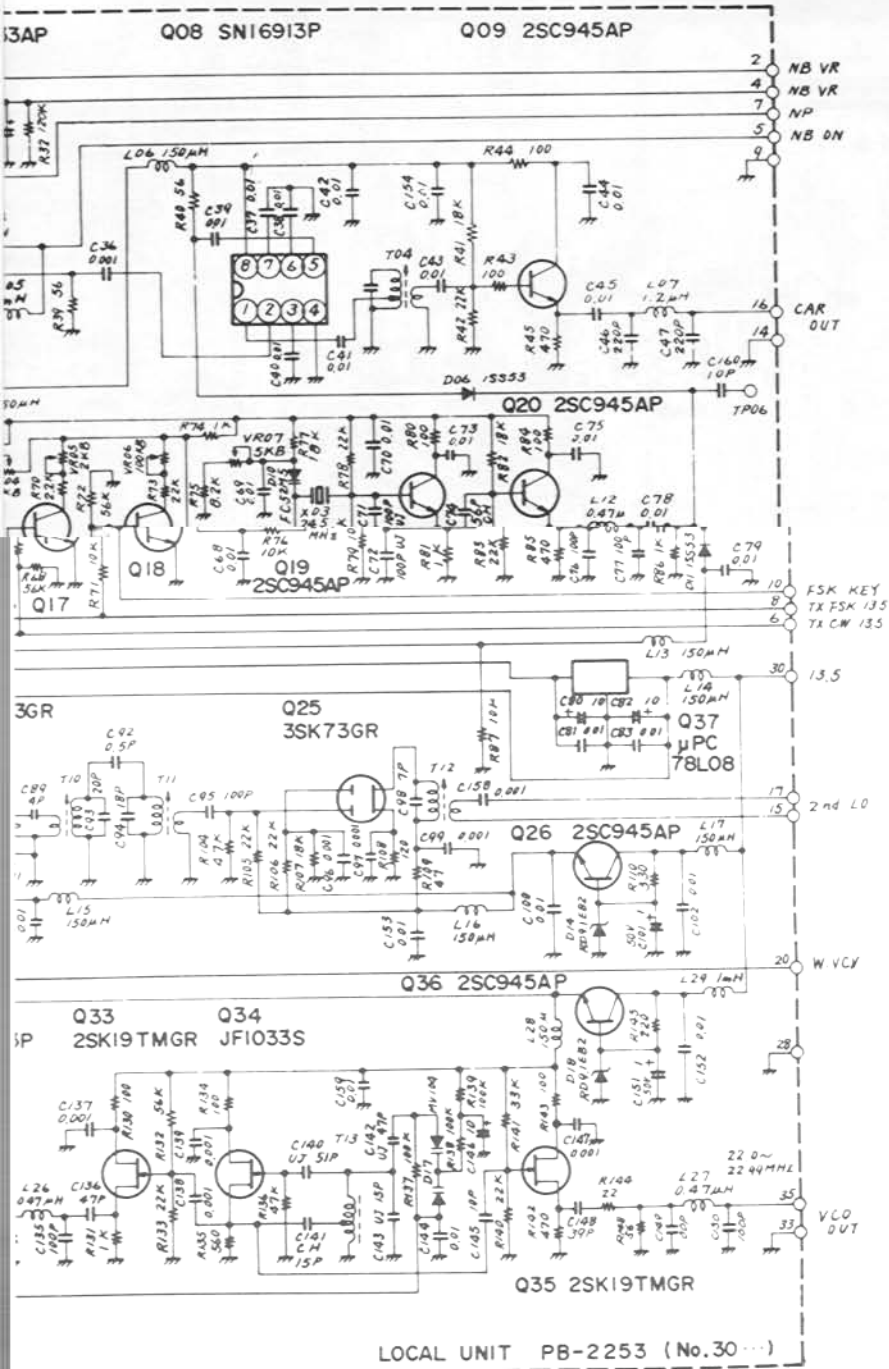

TC01: AM/FM
 TC02: FSK/LSB
 TC03: CW/USB

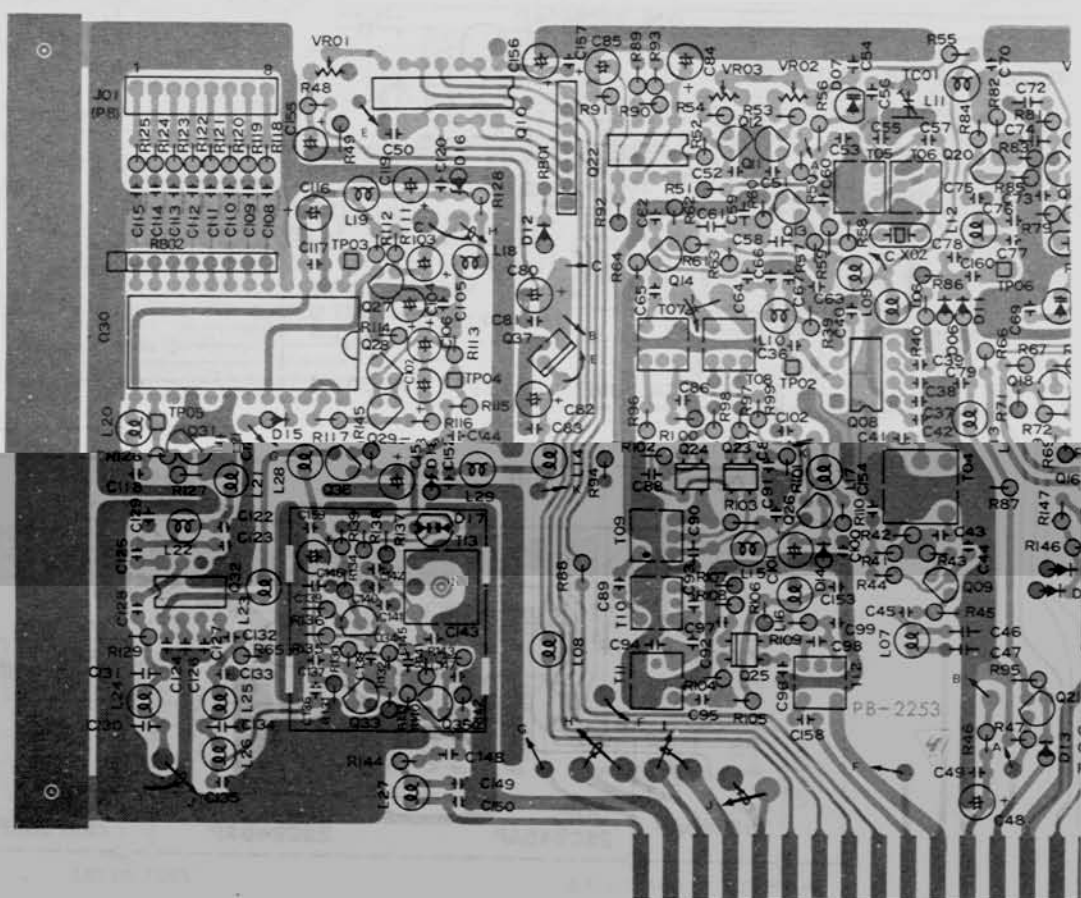
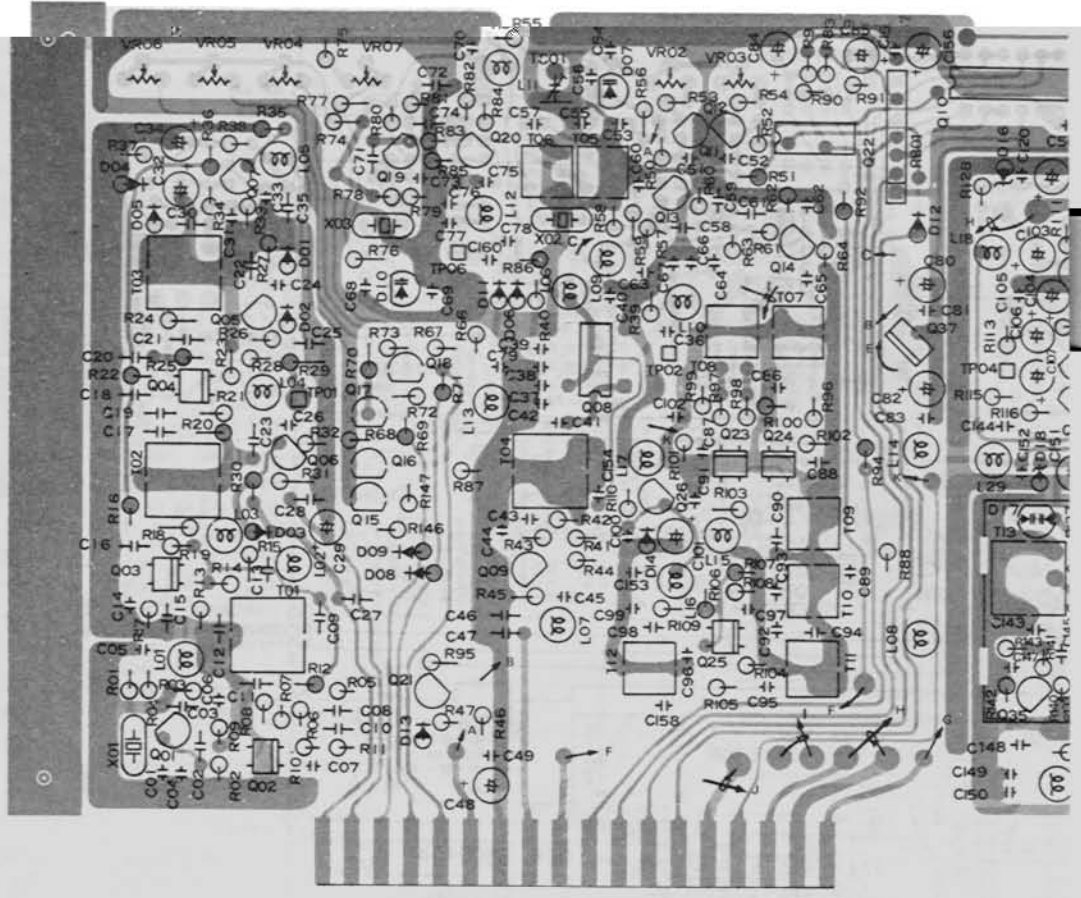

PARTS LAYOUT (Early model)

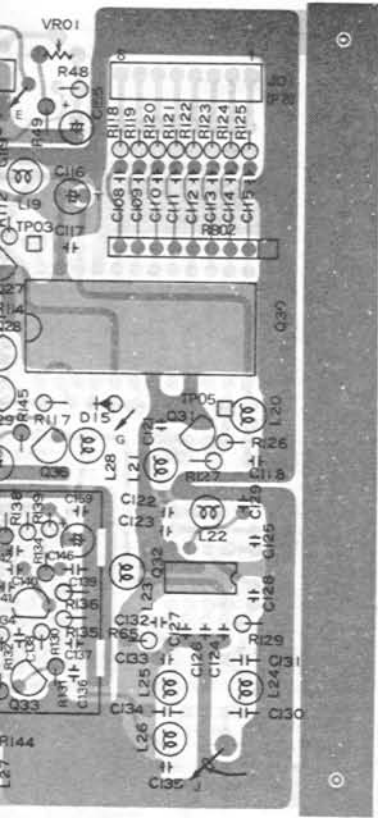

Viewed from component side

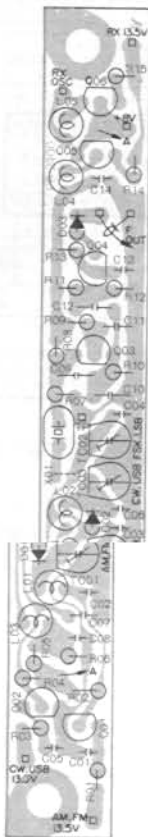
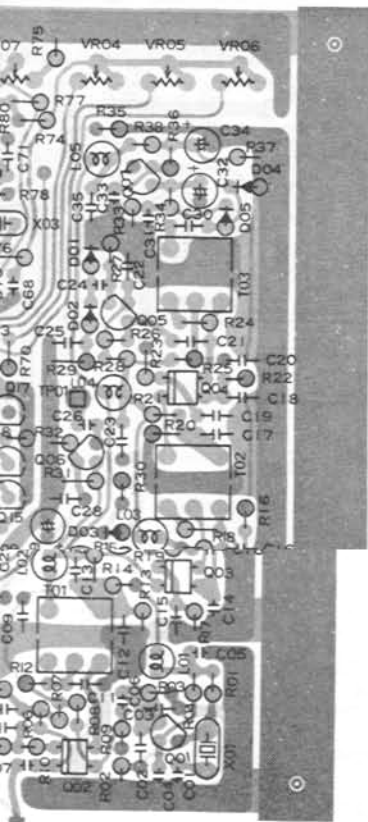

Viewed from solder side

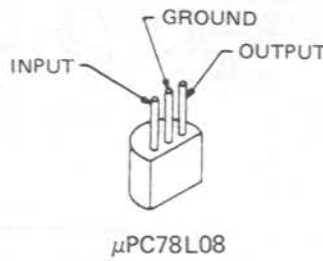
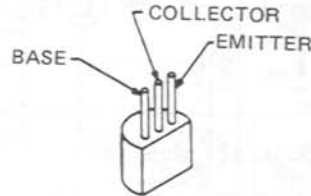
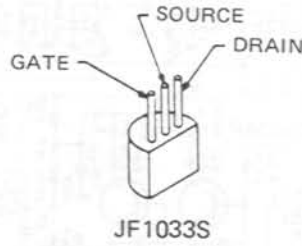
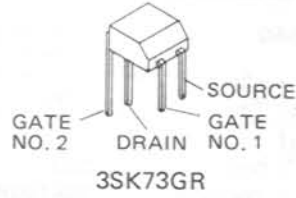

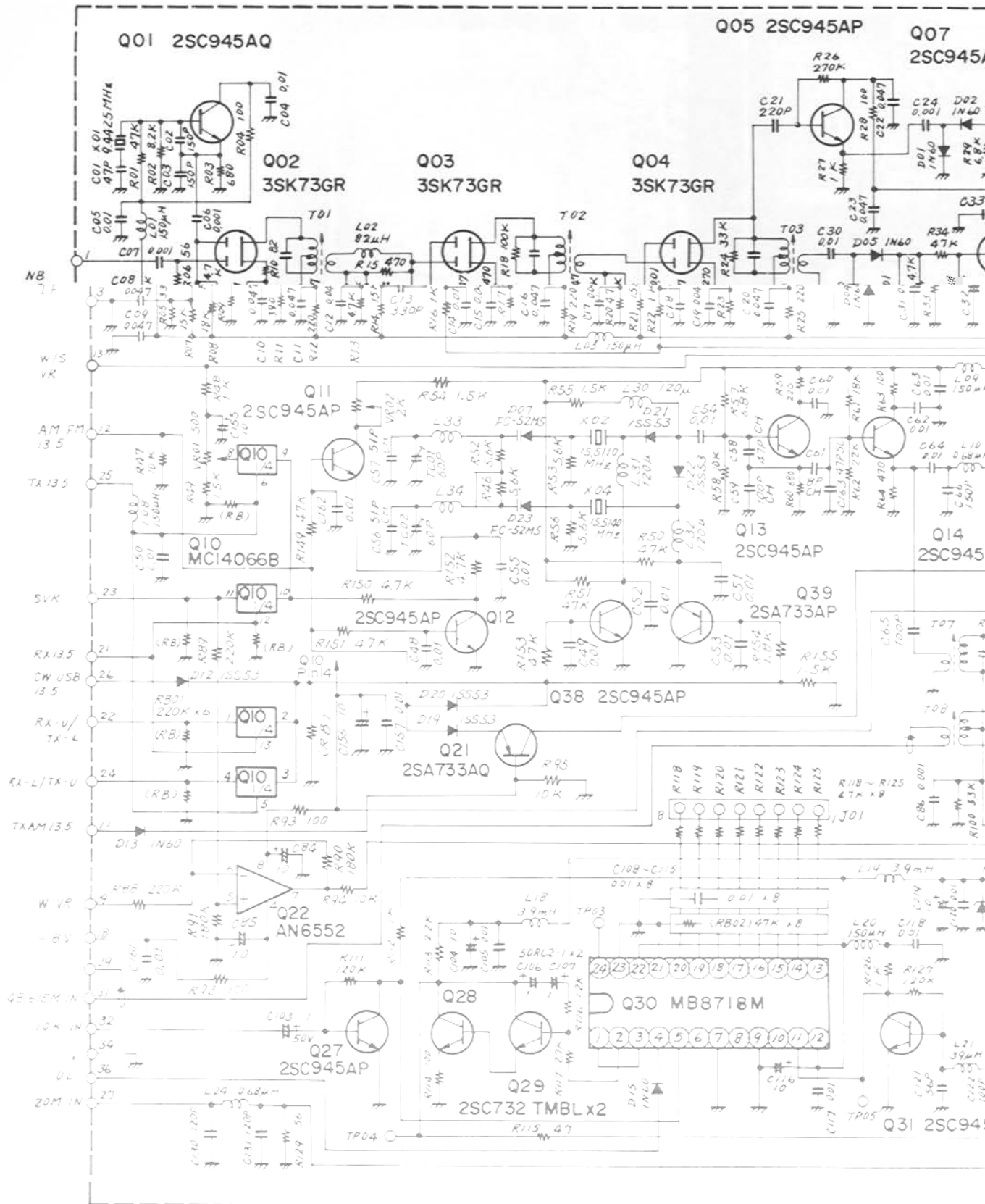

(After prod 6)

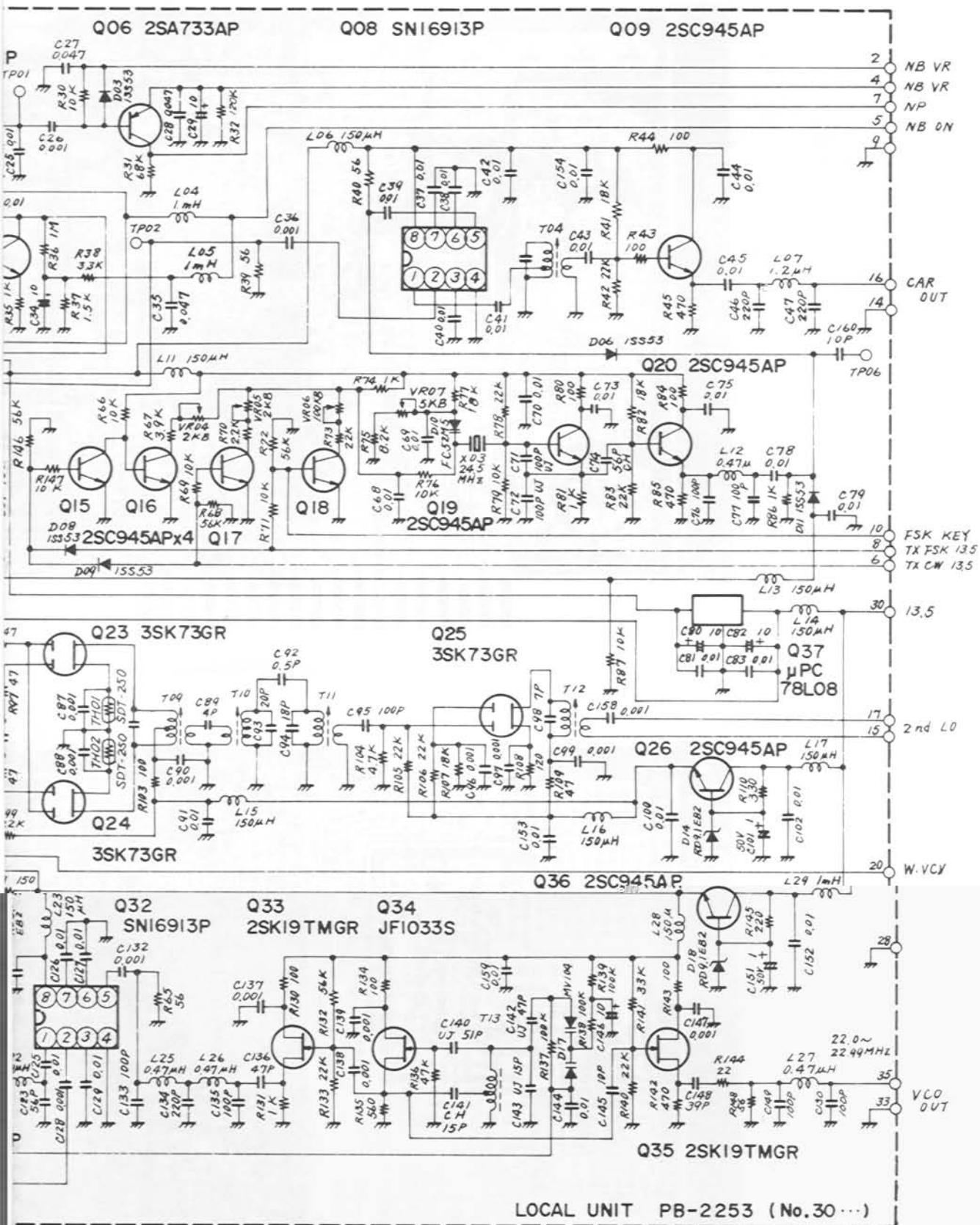

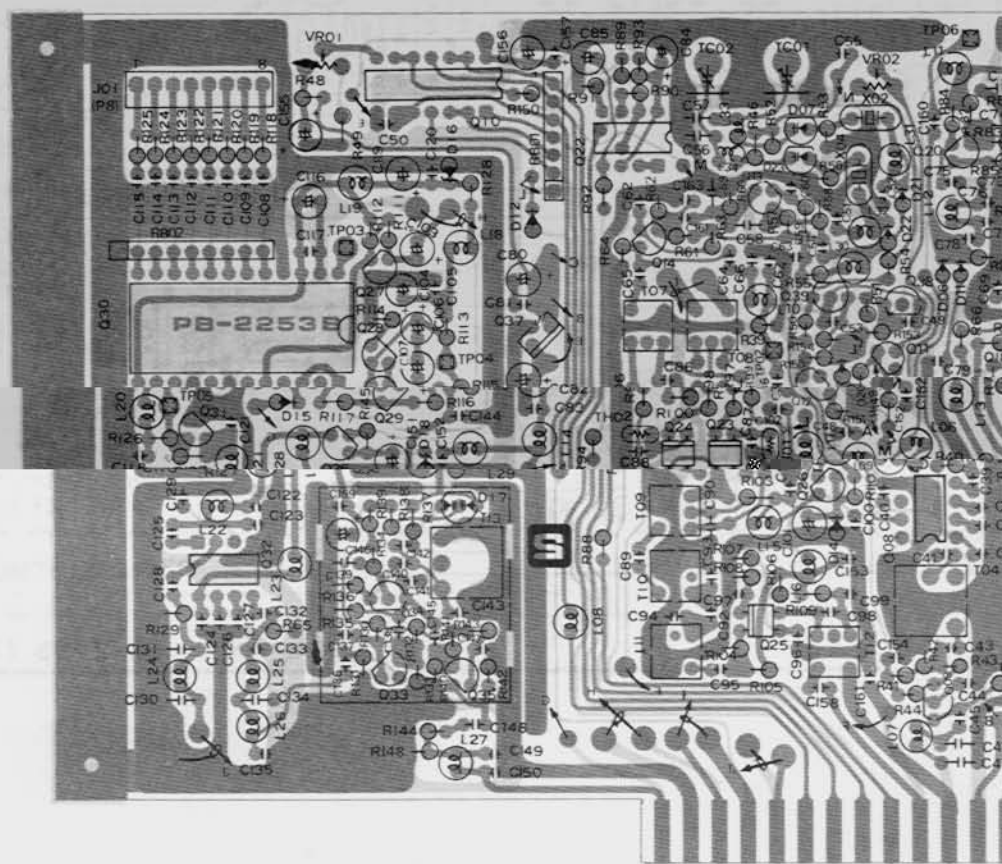
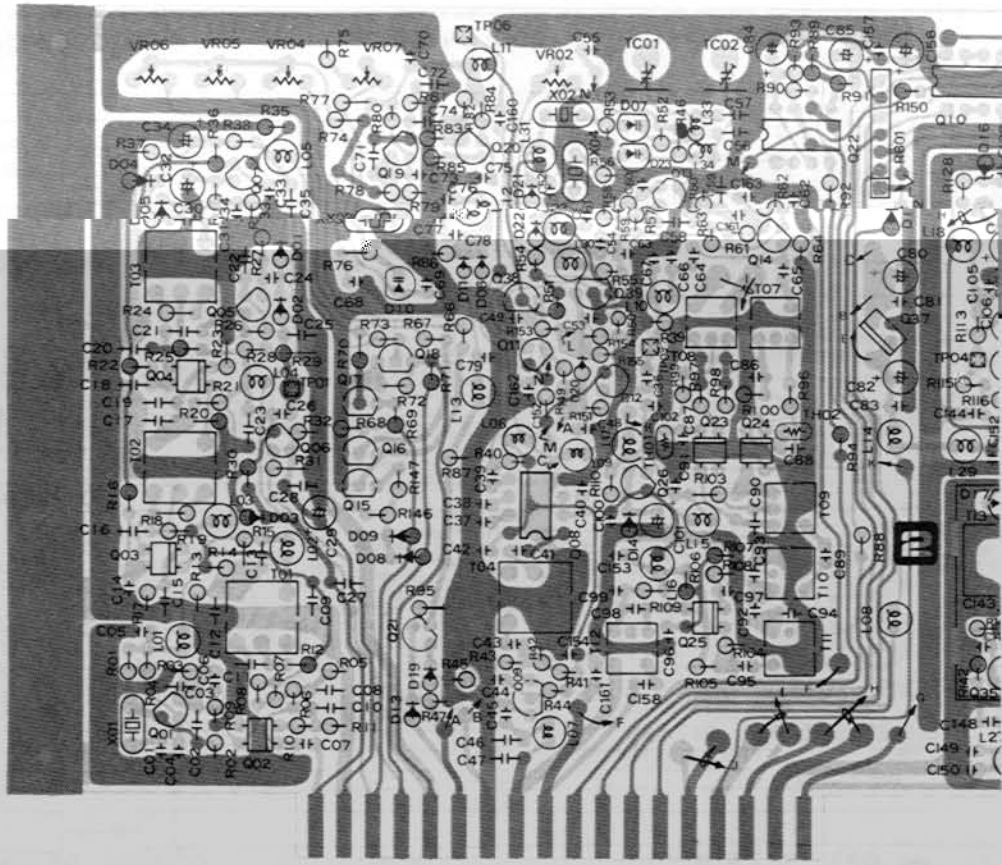

PARTS LAYOUT (After prod 6)

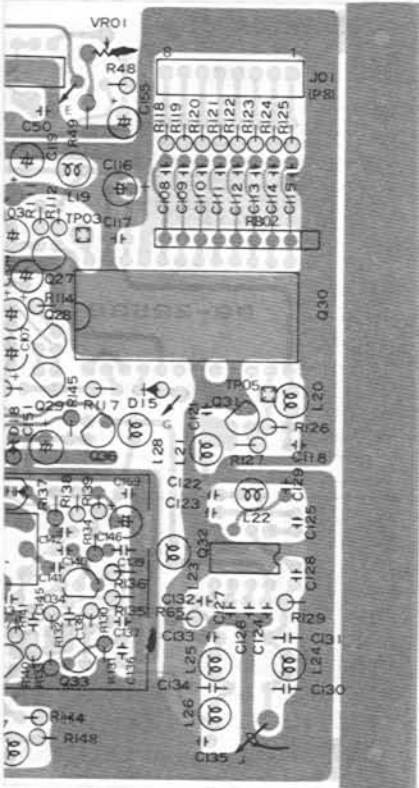

Viewed from component side

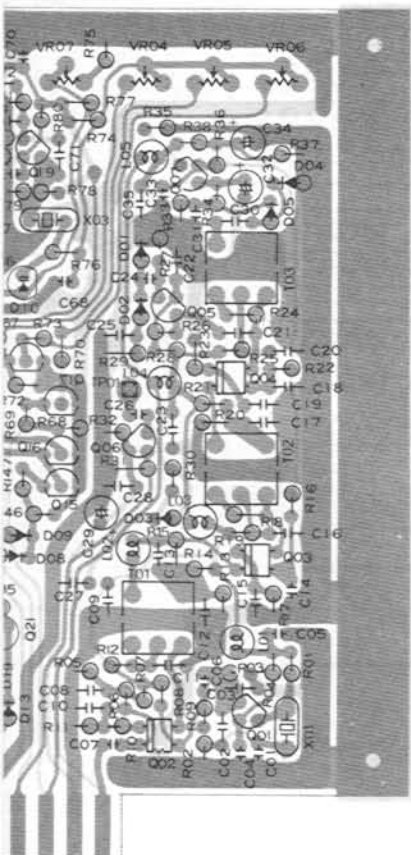

Viewed from solder side

LOCAL UNIT VOLTAGE CHART (DC VOLTS)

	E(S)	C(D)	B(G1)	G2	REMARKS
Q3001	4.5	12.5	1.8		NB ON
Q3002	2.4	11.9	2.4	2.7	NB ON
Q3003	3.2	11.5	3.1	3.8	NB ON
Q3004	2.9	10.8	3.1	3.8	NB ON
Q3005	6.1	12.5	6.7		NB ON
Q3006	7.9/7.9	0/0	8.2/7.9		NB ON NB VR CCW/CW
Q3007	0	3.8	0		NB ON
Q3009	3.6	7.3	4.2		
Q3011	0/0	0/8.0	0.7/0		AM, FM/OTHER
Q3012	0/0	0/8.0	0.7/0		CW, USB/OTHER
Q3013	1.9	7.9	2.5		
Q3014	3.6	7.3	4.2		
Q3015	0	0	0		RX SSB
Q3016	0	0	0.7		RX SSB
Q3017	0	6.5	0		RX SSB
Q3018	0	6.5	0		RX SSB
Q3019	2.1	7.8	2.5		
Q3020	3.5	7.3	4.2		
Q3021	13.5/13.5	13.4/0	12.8/13.0		AM, FM RX/TX AM
Q3023	0.8	7.4	1.1	1.1	
Q3024	0.8	7.4	1.1	1.1	
Q3025	1.1	7.6	1.5	3.7	
Q3026	8.1	13.4	8.8		
Q3027	0	3.0	0		
Q3028	0.1	6.2	0.7		
Q3029	0.7	6.2	1.1		
Q3031	0	2.2	0.4		
Q3033	3.7	8.0	2.4		
Q3034	2.6	7.9	0		
Q3035	2.7	7.7	3.3		
Q3036	8.2	13.4	8.8		

	1	2	3	4	5	6	7	8	9	10	11	12	13	14	REMARKS
Q3008	6.7	3.1	2.8	0	2.8	4.0	4.0	8.1							
Q3010	12.2	12.2	12.2	0	0	0	0	1.2	1.2	0/2.6	0/2.6	13.5	13.5	13.3	SHIFT VR CCW/CW
Q3032	6.9	4.2	3.0	0	2.9	4.2	4.2	8.3							

	1	2	3	4	5	6	7	8	9	10	11	12	13	14	15	16
Q3030	0	1.1	0	5.0(0)	3.0	-	0	-	0	-	2.2	5.0	4.9/0	4.9/0	4.9/0	4.9/0
17	18	19	20	21	22	23	24	REMARKS								
4.9/0	4.9/0	4.9/0	4.9/0	0	5.0	0	4.9	DATA High/Low, (UNLOCK)								

	IN	OUT	REMARKS
Q3037	13.3	8.1	

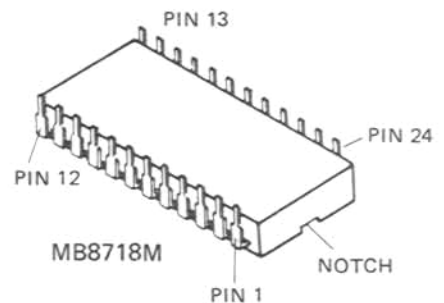
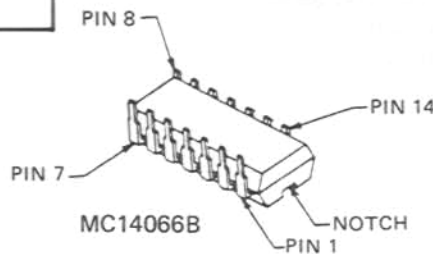
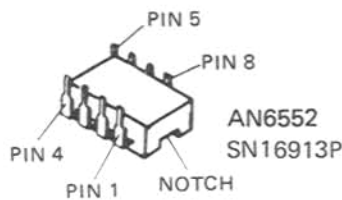

SERVICING

LOCAL UNIT COMPONENT APPLICATIONS

Q3001	2SC945AQ	Transistor	RX NB Oscillator	D3001	1N60	Ge Diode	RX NV Noise
Q3002	3SK73GR	Dual Gate	RX NB Mixer				Detector
		MOS FET		D3002	"	"	"
Q3003	"	"	RX NB IF	D3003	1SS53	Si Diode	Clipper
			Amplifier	D3004	1N60	Ge Diode	RX NB AGC
Q3004	"	"	"				Detector
Q3005	2SC945AP	Transistor	RX NB Buffer	D3005	"	"	"
			Amplifier	D3006	1SS53	Si Diode	Switch
Q3006	2SA733AP	"	NB Controller	D3007	FC52M5	Varactor	VCXO (for ALL
Q3007	2SC945AP	"	NB AGC			Diode	MODES)
			Amplifier	D3008	1SS53	Si Diode	Switch
Q3008	SN16913P	IC	CARRIER Mixer	D3009	"	"	"
Q3009	2SC945AP	Transistor	CARRIER Buffer	D3010	FC52M5	Varactor	VCXO (for SSB, CW,
			Amplifier			Diode	FSK)
Q3010	MC14066B	IC	MODE Selector	D3011	1SS53	Si Diode	Switch
Q3011	2SC945AP	Transistor	"	D3012	"	"	"
Q3012	"	"	"	D3013	1N60	Ge Diode	"
Q3013	"	"	VCXO (for ALL	D3014	RD9.1EB2	Zener Diode	Regulator
			MODES)	D3015	1N60	Ge Diode	Switch
Q3014	"	"	VCXO Buffer	D3016	RD5.1EB2	Zener Diode	Regulator
			Amplifier	D3017	MV104	Varactor	PLL VCO-1
Q3015	"	"	VCXO Frequency			Diode	
			Controller	D3018	RD9.1EB2	Zener Diode	Regulator
Q3016	"	"	"				
Q3017	"	"	"	X3001	9.4425MHz	Crystal	NB Oscillator
Q3018	"	"	"	X3002	15.5125MHz	"	VCXO (for ALL
Q3019	"	"	VCXO (for SSB, CW,				MODES)
			FSK)	X3003	24.5MHz	"	VCXO (for SSB, CW,
Q3020	"	"	VCXO Buffer				FSK)
			Amplifier				
Q3021	2SA733AQ	"	Switch				
Q3022	AN6552	IC	RX Shift, Width				
			Controller				
Q3023	3SK73GR	Dual Gate	RX 2nd LOCAL	Q2301	2SC945AP	Transistor	Switch (for AM, FM)
		MOS FET	Premixer	Q2302	"	"	" (for CW, USB)
			TX 1st LOCAL	Q2303	"	"	TX Carrier Oscillator
Q3024	"	"	Premixer	Q2304	"	"	TX Carrier OSC
			"				Buffer Amplifier
			"				Switch
Q3025	"	"	RX 2nd LOCAL	Q2305	2SA733AP	"	
			Amplifier	Q2306	2SC945AP	"	"
			TX 1st LOCAL				
Q3026	2SC945AP	Transistor	Amplifier	D2301	1SS97	Schottky	Switch (for AM, FM)
Q3027	"	"	Regulator	D2302	"	Barrier Di	
			PLL VCO-1	D2303	1SS53	Si Diode	" (for CW, USB)
Q3028	2SC732TMBL	"	Reference Amplifier				"
			PLL VCO-1 Active	X2301	15.514MHz	Crystal	TX Carrier Oscillator
Q3029	"	"	LPF				
Q3030	MB8718M	IC	"				
			PLL VCO-1 DIV,				
			PH. DET.				
Q3031	2SC945AP	Transistor	PLL VCO-1 IF				
			Amplifier				
Q3032	SN16913P	IC	PLL VCO-1 Mixer				
Q3033	2SK19TMGR	Junction FET	PLL VCO-1 Buffer				
			Amplifier				
Q3034	JF1033S	"	PLL VCO-1				
Q3035	2SK19TMGR	"	PLL VCO-1 Buffer				
			Amplifier				
Q3036	2SC945AP	Transistor	Regulator				

TX CAR OSC UNIT

Q2301	2SC945AP	Transistor	Switch (for AM, FM)
Q2302	"	"	" (for CW, USB)
Q2303	"	"	TX Carrier Oscillator
Q2304	"	"	TX Carrier OSC
			Buffer Amplifier
Q2305	2SA733AP	"	Switch
Q2306	2SC945AP	"	"
D2301	1SS97	Schottky	Switch (for AM, FM)
		Barrier Di	
D2302	"	"	" (for CW, USB)
D2303	1SS53	Si Diode	"
X2301	15.514MHz	Crystal	TX Carrier Oscillator

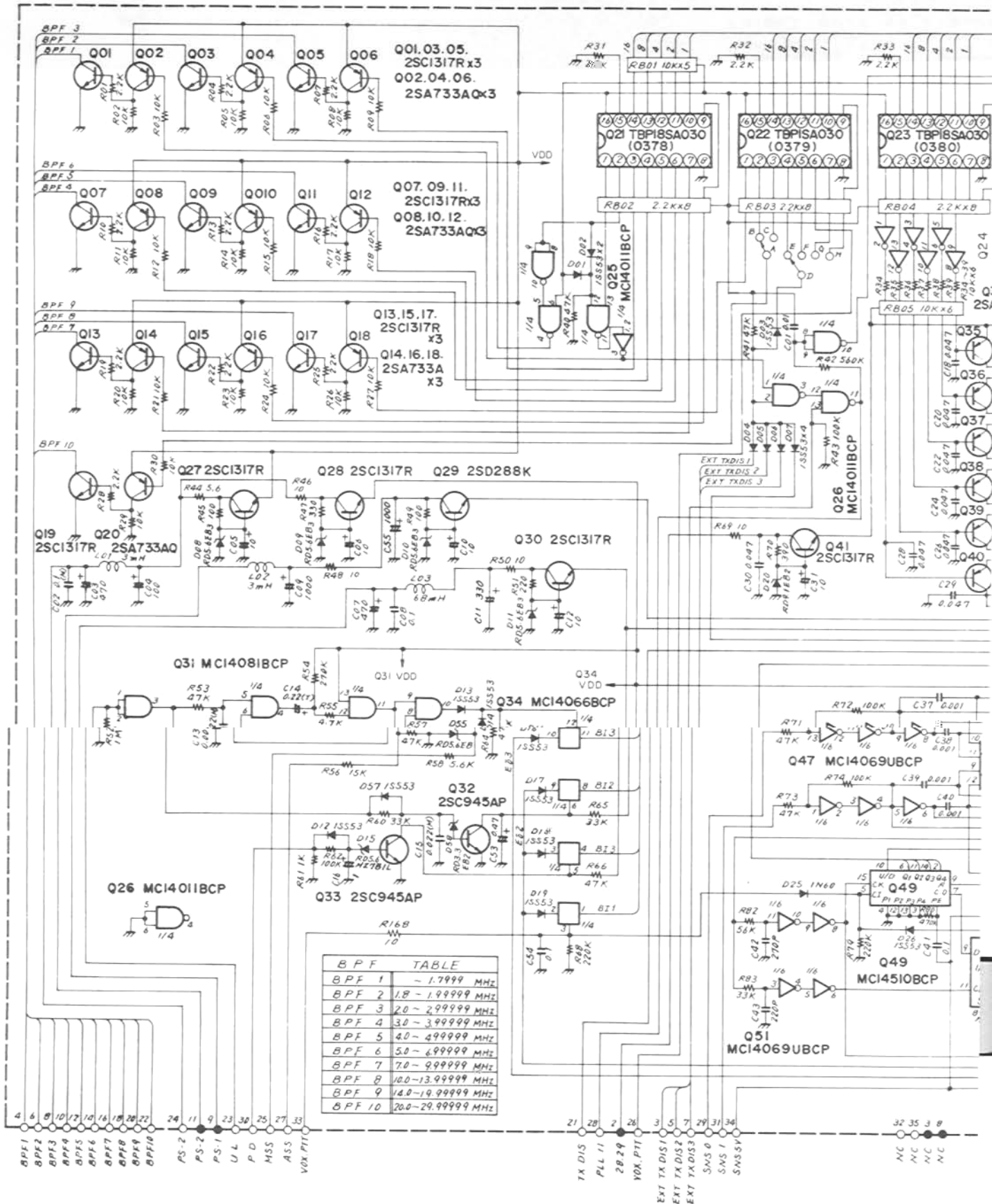

BPF	FREQUENCY
BPF 1	1.79999 MHz
BPF 2	1.8 - 1.99999 MHz
BPF 3	2.0 - 2.99999 MHz
BPF 4	3.0 - 3.99999 MHz
BPF 5	4.0 - 4.99999 MHz
BPF 6	5.0 - 6.99999 MHz
BPF 7	7.0 - 9.99999 MHz
BPF 8	10.0 - 13.99999 MHz
BPF 9	14.0 - 19.99999 MHz
BPF 10	20.0 - 29.99999 MHz

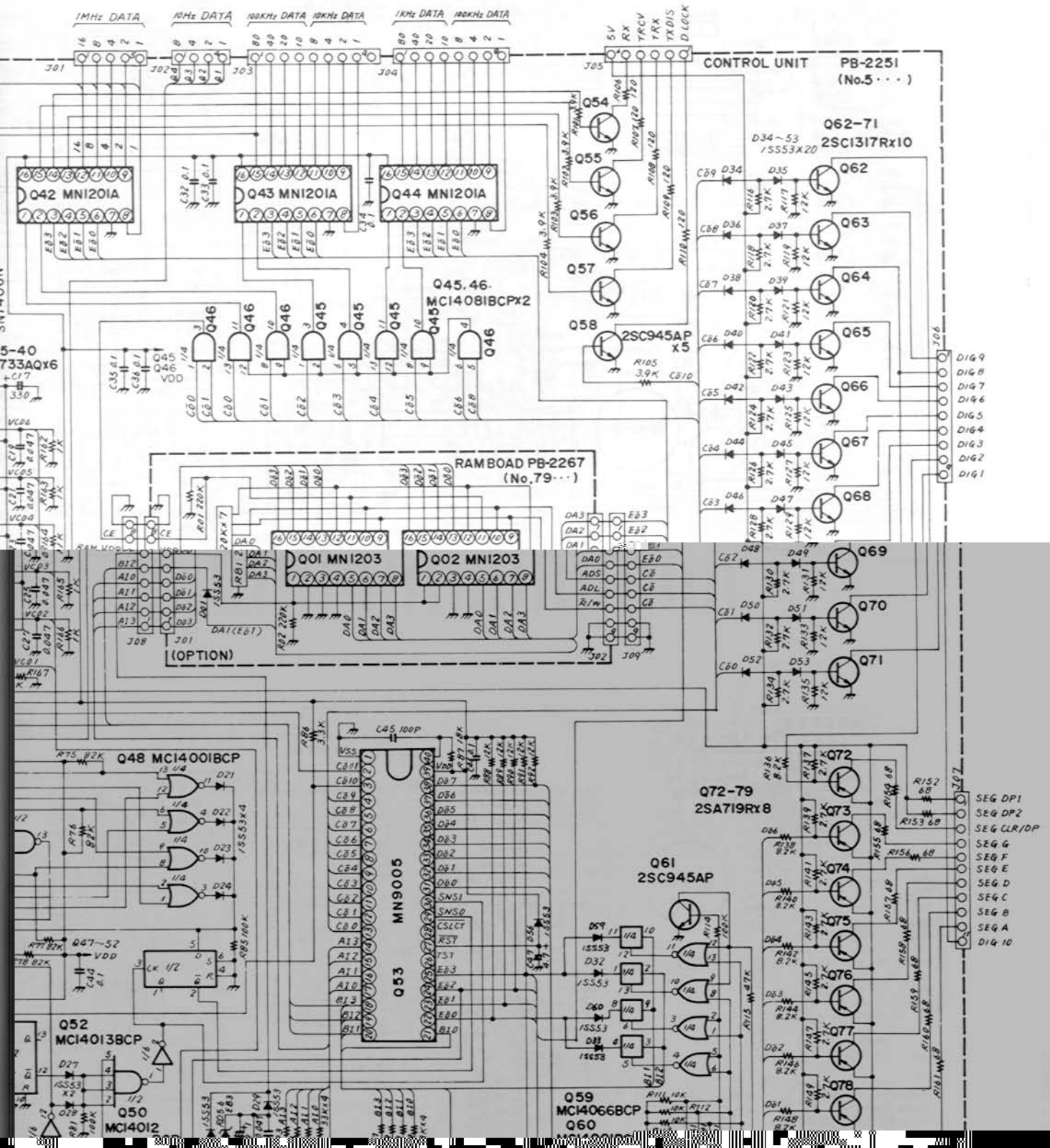

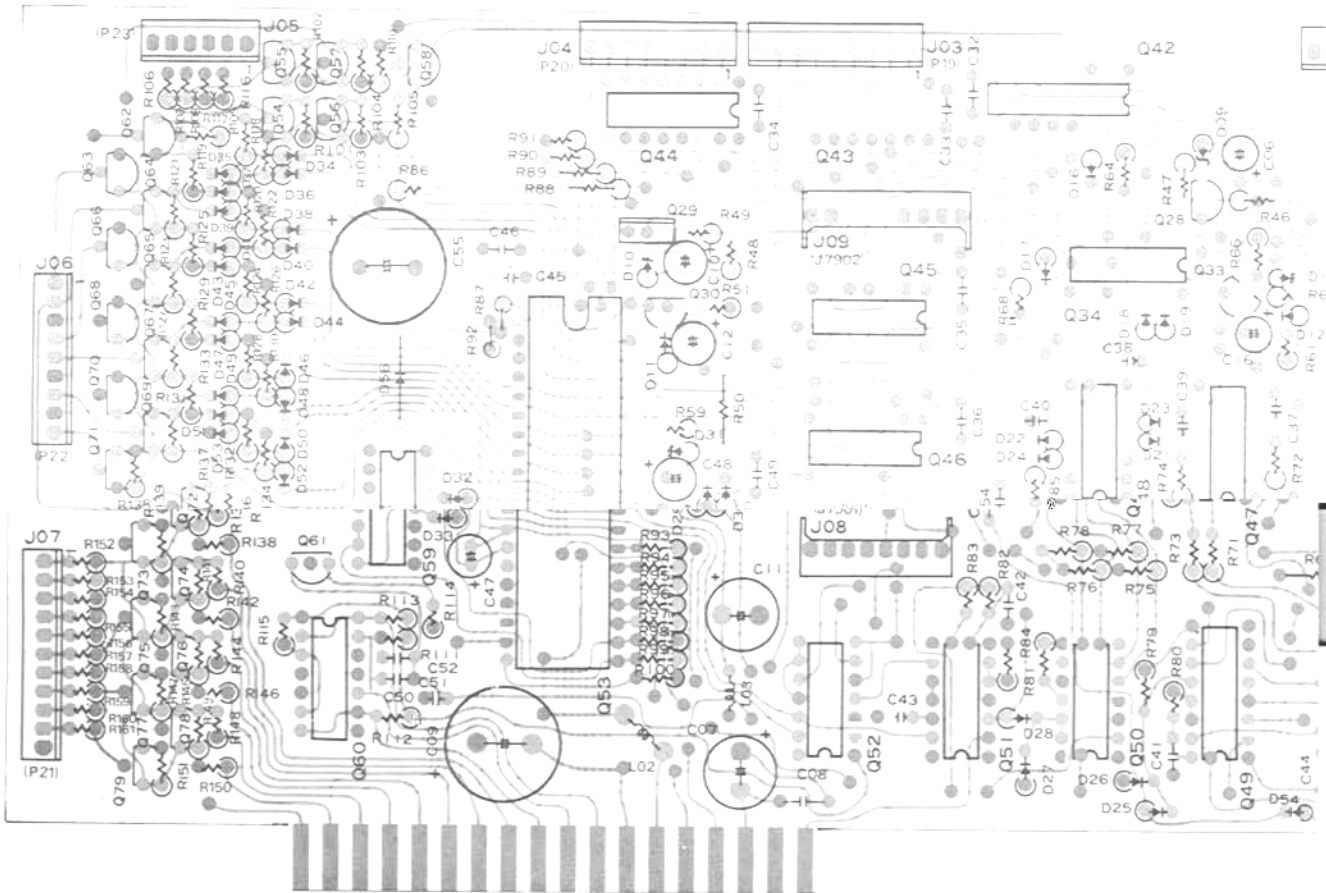
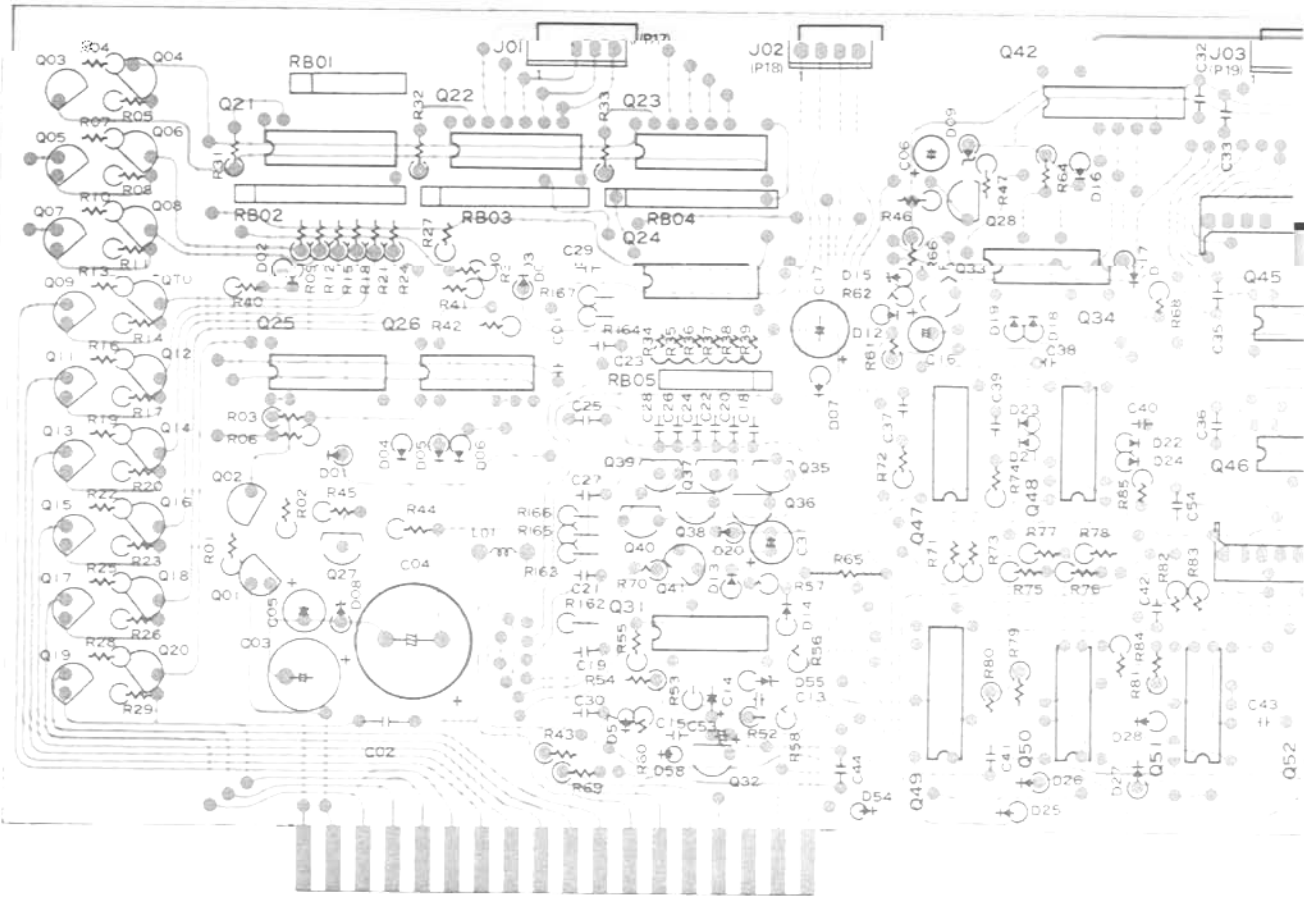

PARTS LAYOUT

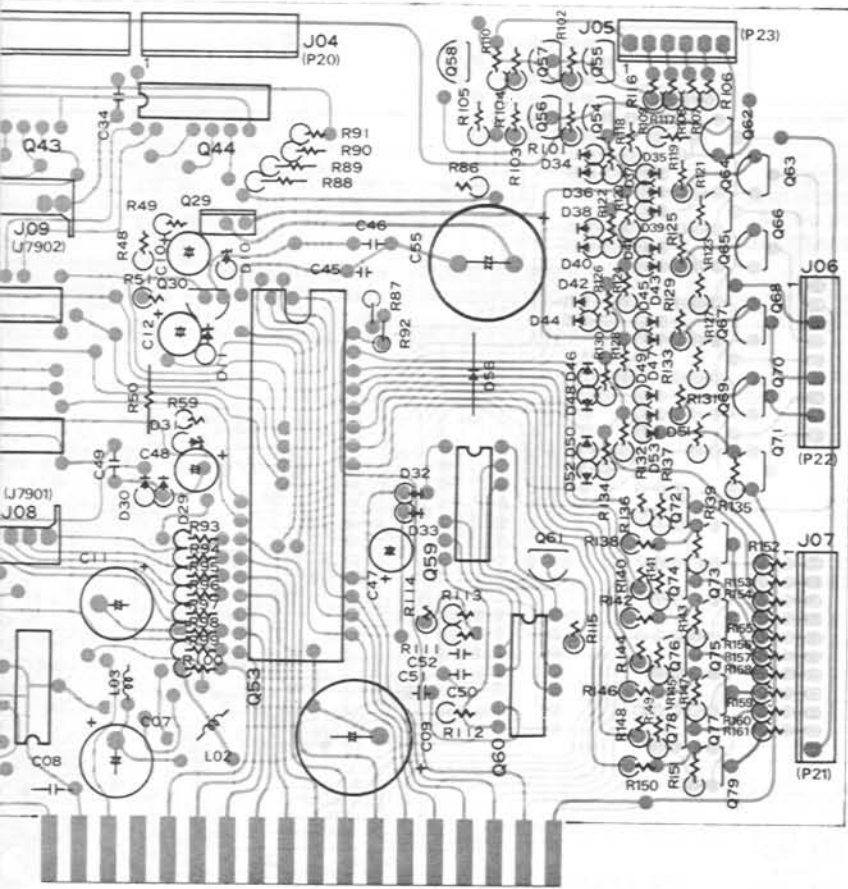

Viewed from component side

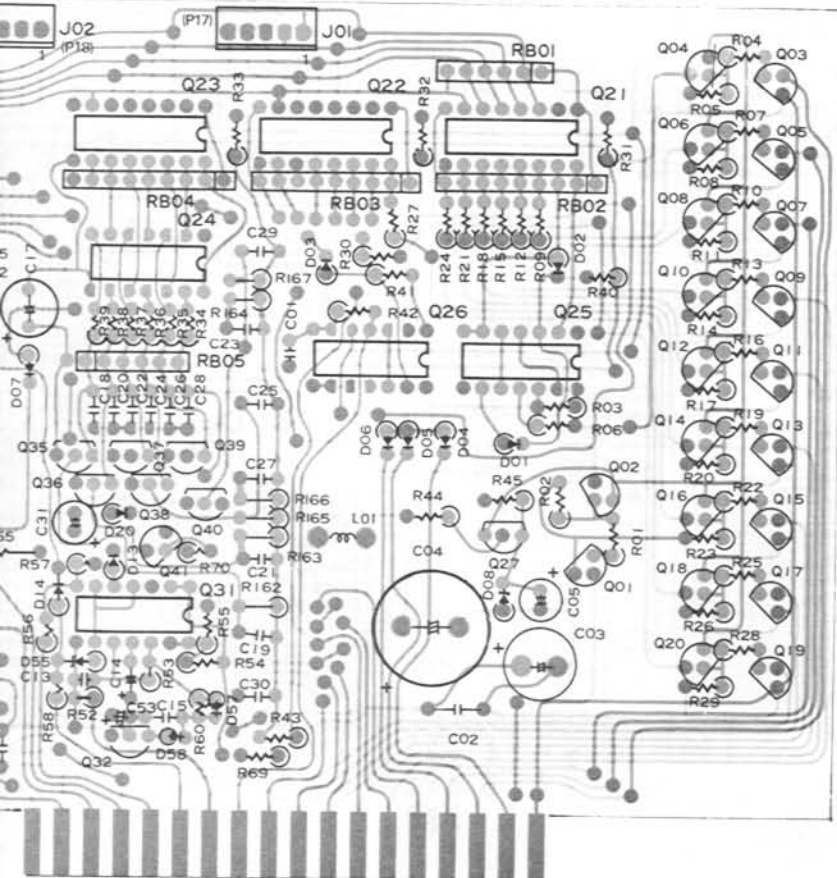

Viewed from solder side

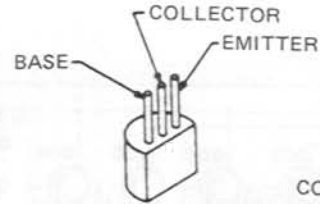

2SA719R
2SA733AQ
2SC945AP
2SC1317R

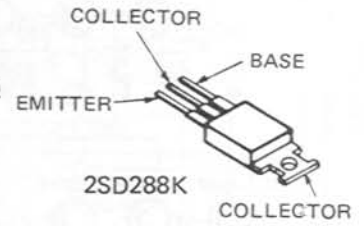

2SD288K

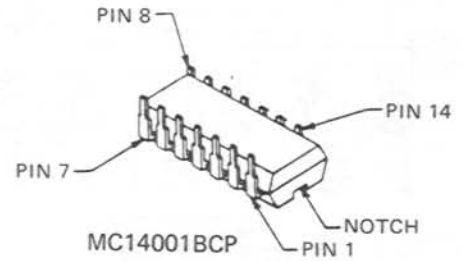

MC14001BCP
MC14011BCP
MC14012BCP
MC14013BCP
MC14066BCP
MC14069UBCP
MC14081BCP
SN7406N

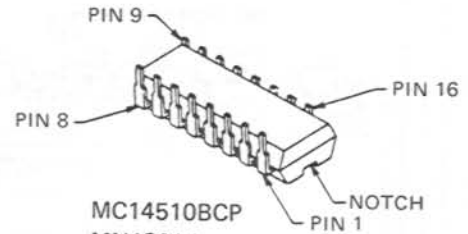

MC14510BCP
MN1201A
TBP18SA030

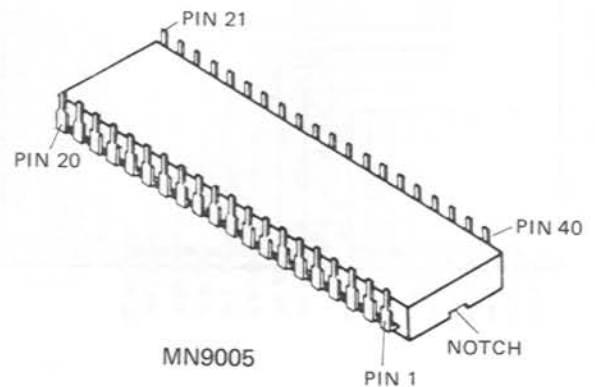

MN9005

CONTROL UNIT

VOLTAGE CHART (DC VOLTS)

	E	C	B	REMARKS
Q5027	5.1	6.2	5.8	
Q5028	5.1	7.0	5.9	
Q5029	5.3	6.5	5.9	
Q5030	5.3	7.3	6.1	
Q5032	0	0.7(0)	0(5.1)	(UNLOCK)
Q5033	0	0.6(0)	0(5.4)	(POWER DOWN)
Q5041	8.4	13.3	9.1	

COMPONENT APPLICATIONS

Q5001	2SC1317R	Transistor	BPF Selector	Q5050	MC14012BCP	IC	Counter
Q5002	2SA733AQ	"	"	Q5051	MC14069UBCP	"	"
Q5003	2SC1317R	"	"	Q5052	MC14013BCP	"	"
Q5004	2SA733AQ	"	"	Q5053	MN9005	"	CPU
Q5005	2SC1317R	"	"	Q5054	2SC945AP	Transistor	LED Driver
Q5006	2SA733AQ	"	"	Q5055	"	"	"
Q5007	2SC1317R	"	"	Q5056	"	"	"
Q5008	2SA733AQ	"	"	Q5057	"	"	"
Q5009	2SC1317R	"	"	Q5058	"	"	"
Q5010	2SA733AQ	"	"	Q5059	MC14066BCP	IC	Switch
Q5011	2SC1317R	"	"	Q5060	MC14001BCP	"	"
Q5012	2SA733AQ	"	"	Q5061	2SC945AP	Transistor	"
Q5013	2SC1317R	"	"	Q5062	2SC1317R	"	LED Digit Driver
Q5014	2SA733AQ	"	"		}	}	}
Q5015	2SC1317R	"	"	Q5071	"	"	"
Q5016	2SA733AQ	"	"	Q5072	2SA719R	"	LED Segment Driver
Q5017	2SC1317R	"	"		}	}	}
Q5018	2SA733AQ	"	"	Q5079	"	"	"
Q5019	2SC1317R	"	"				
Q5020	2SA733AQ	"	"				
Q5021	TBP18SA030	IC	ROM	D5001	1SS53	Si Diode	Switch
Q5022	"	"	"	D5002	"	"	"
Q5023	"	"	"	D5003	"	"	"
Q5024	SN7406N	"	VCO Selector Driver Amplifier	D5004	"	"	"
				D5005	"	"	"
Q5025	MC14011BCP	"	BPF Selector	D5006	"	"	"
Q5026	"	"	TX Disable Switch	D5007	1SS53	Si Diode	Switch
Q5027	2SC1317R	Transistor	Regulator	D5008	RD5.6EB3	Zener Diode	Regulator
Q5028	"	"	"	D5009	"	"	"
Q5029	2SD288K	"	"	D5010	"	"	"
Q5030	2SC1317R	"	"	D5011	"	"	"
Q5031	MC14081BCP	IC	Scan Controller	D5012	1SS53	Si Diode	Switch
Q5032	2SC945AP	Transistor	Unlock Signal Amplifier	D5013	"	"	"
				D5014	"	"	"
Q5033	"	"	Power Down Switch	D5015	RD5.6EB3	Zener Diode	"
Q5034	MC14066BCP	IC	Switch	D5016	1SS53	Si Diode	"
Q5035	2SA733AQ	Transistor	VCO Selector	D5017	"	"	"
Q5036	"	"	"	D5018	"	"	"
Q5037	"	"	"	D5019	"	"	"
Q5038	"	"	"	D5020	RD9.1EB2	Zener Diode	Regulator
Q5039	"	"	"	D5021	1SS53	Si Diode	Switch
Q5040	"	"	"	D5022	"	"	"
Q5041	2SC1317R	"	Regulator	D5023	"	"	"
Q5042	MN1201A	IC	Latch	D5024	"	"	"
Q5043	"	"	"	D5025	1N60	Ge Diode	"
Q5044	"	"	"	D5026	1SS53	Si Diode	"
Q5045	MC14081BCP	"	Gate	D5027	"	"	"
Q5046	"	"	"	D5028	"	"	"
Q5047	MC14069BCP	"	10Hz/100Hz Counter	D5029	"	"	"
				D5030	"	"	"
Q5048	MC14001BCP	"	"	D5031	RD5.6EB3	Zener Diode	Regulator
Q5049	MC14510BCP	"	"				

CONTROL UNIT

D5032	1SS53	Si Diode	Switch
D5052	"	"	"
D5053	1SS53	Si Diode	Switch
D5054	Not Used		
D5055	RD5.6EB	Zener Diode	Regulator
D5056	1SS53	Si Diode	Switch
D5057	"	"	"
D5058	RD3.3EB2	Zener Diode	"

COMPONENT APPLICATIONS

Q7901	MN1203	IC	RAM
Q7902	"	"	"
D7901	1SS53	Si Diode	Switch

RAM BOARD UNIT PARTS LAYOUT

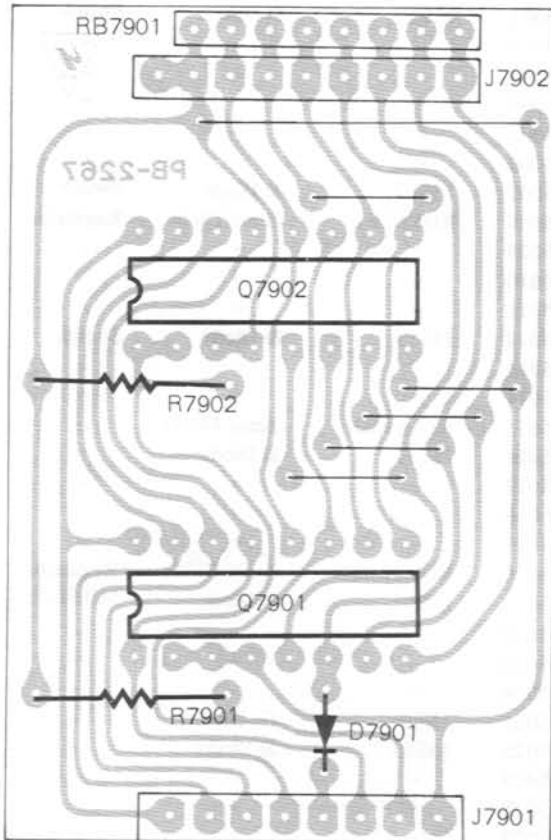
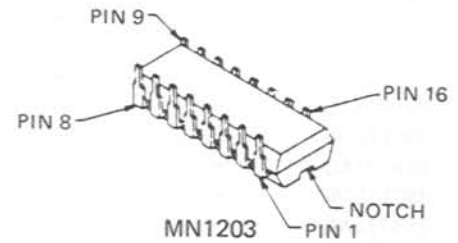
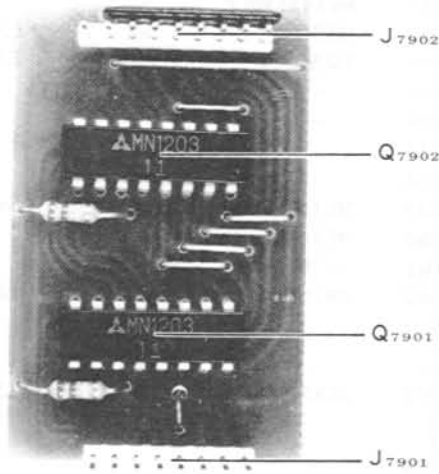

Viewed from component side

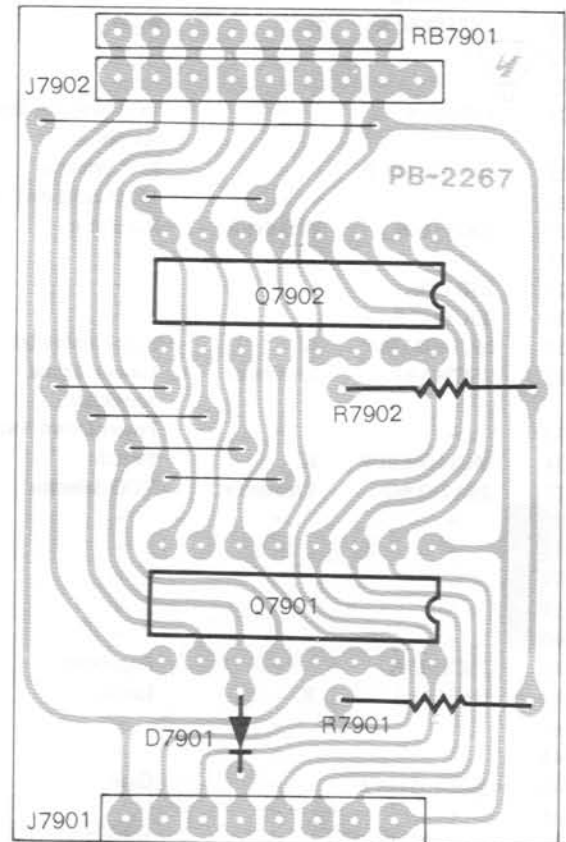

Viewed from foil side

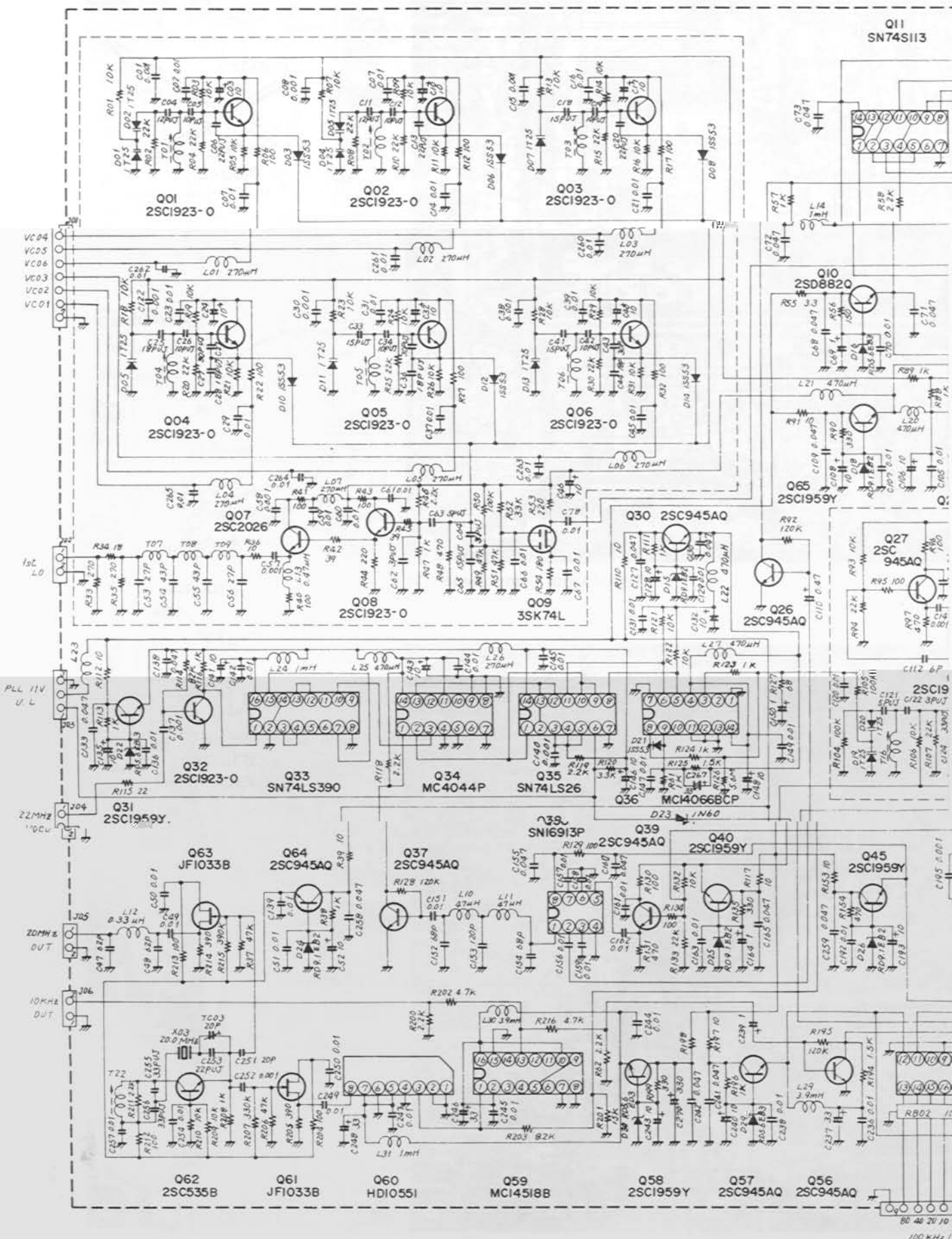

(Early model)

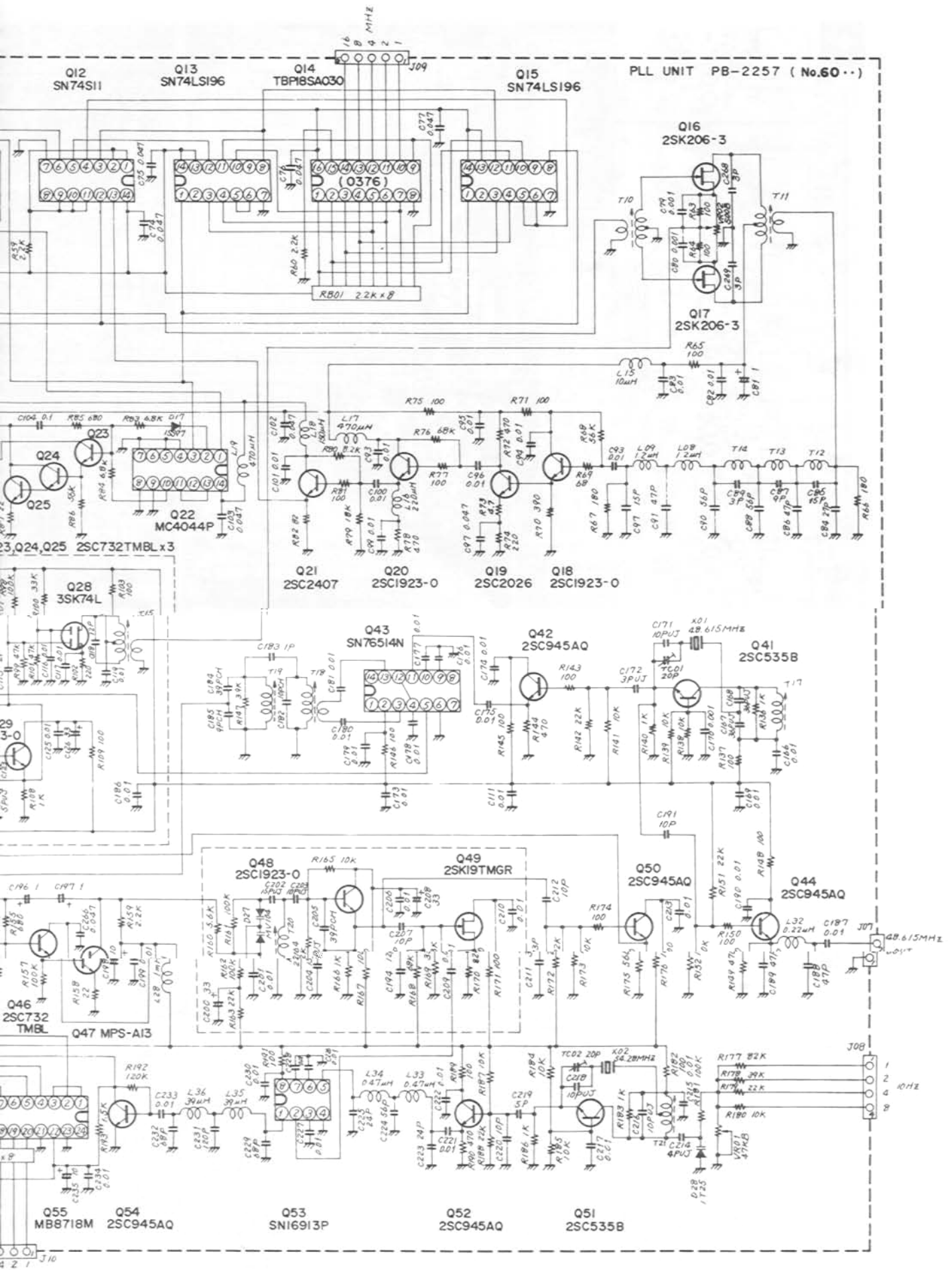

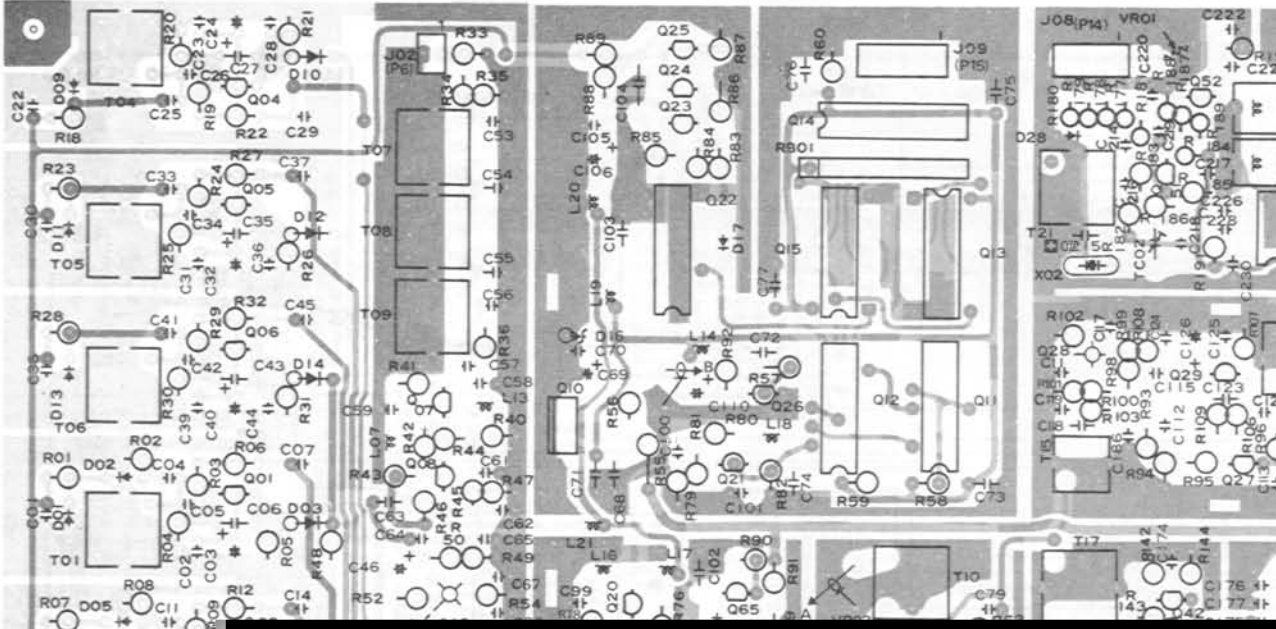

T PARTS LAYOUT (Early model)

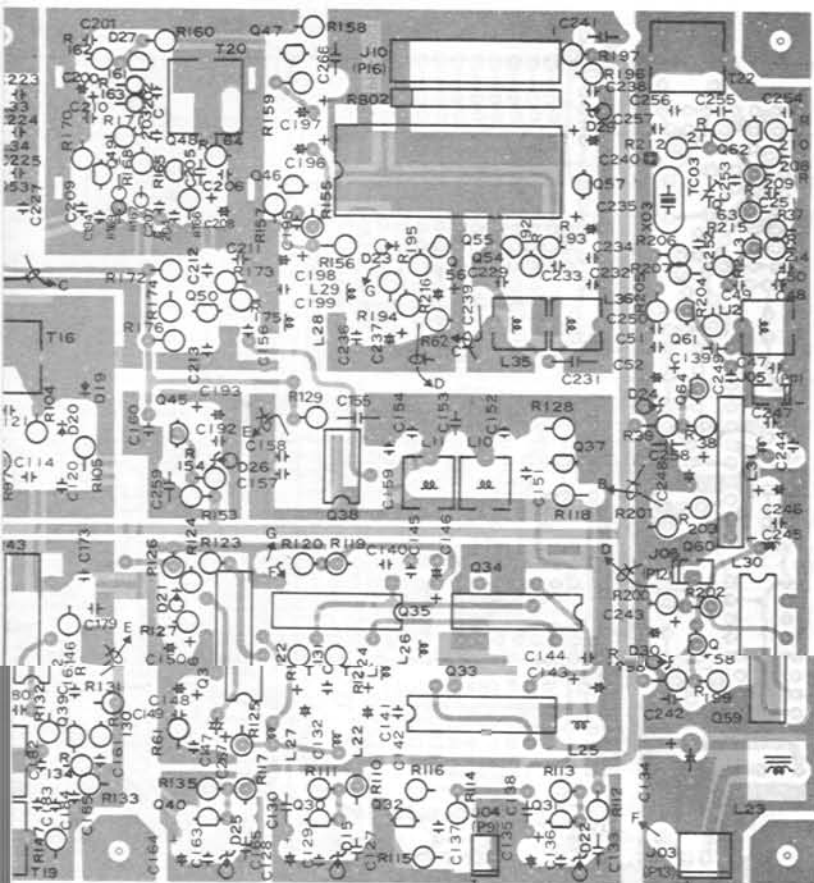

Viewed from component side

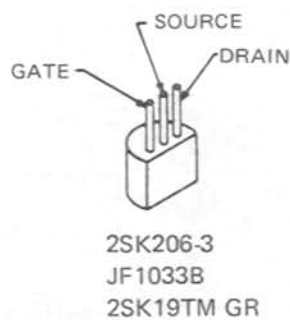
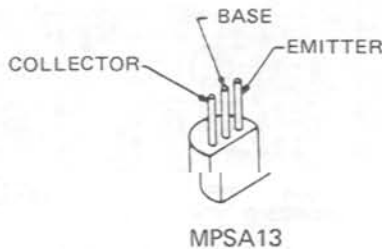
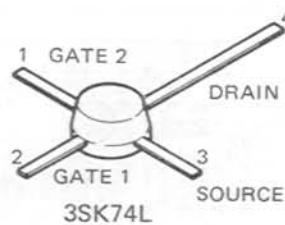
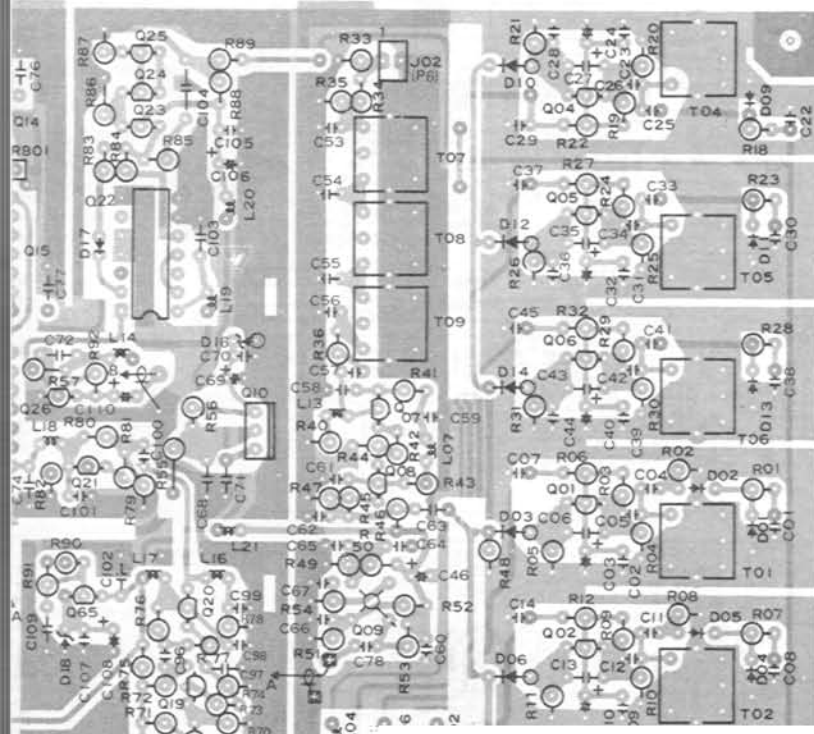

(After prod 7)

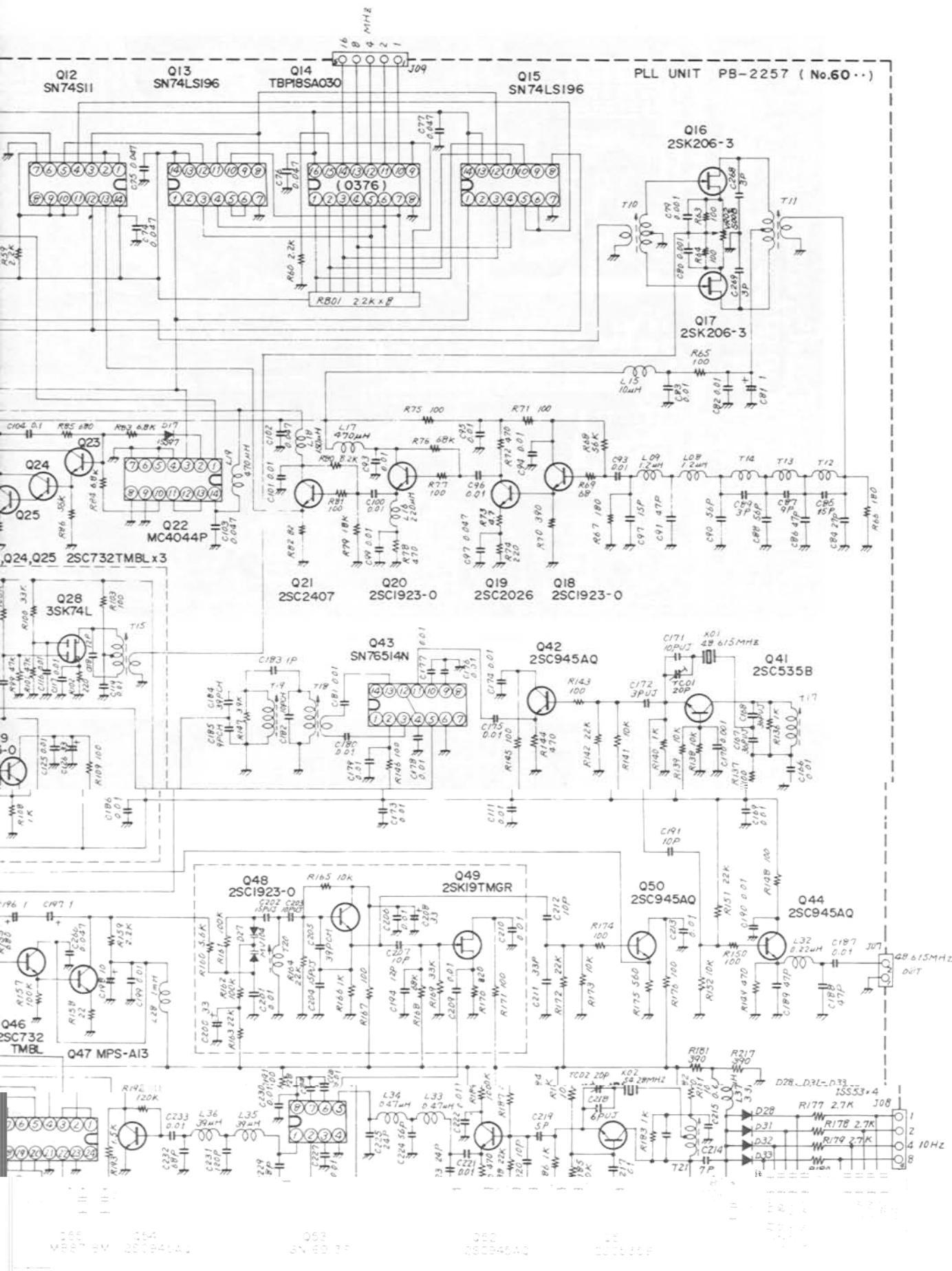

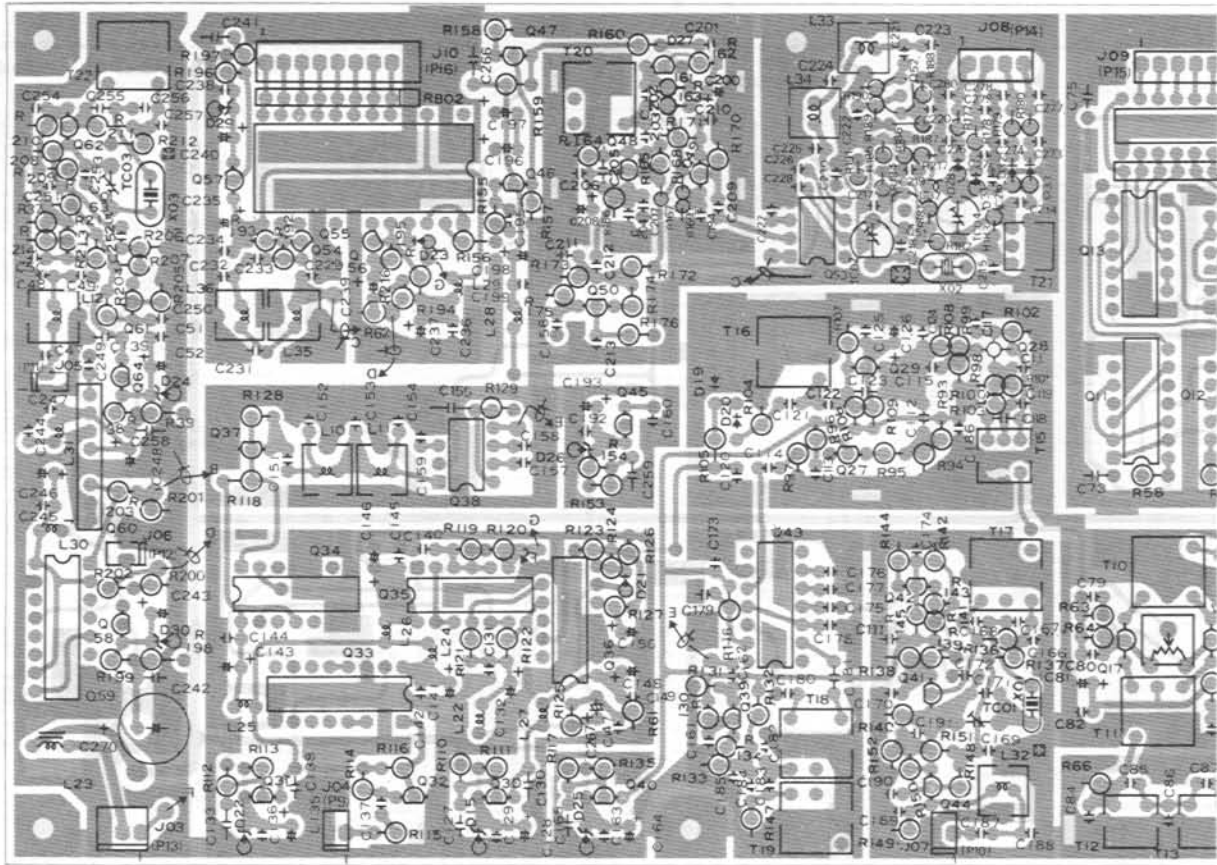

PARTS LAYOUT (After prod 7)

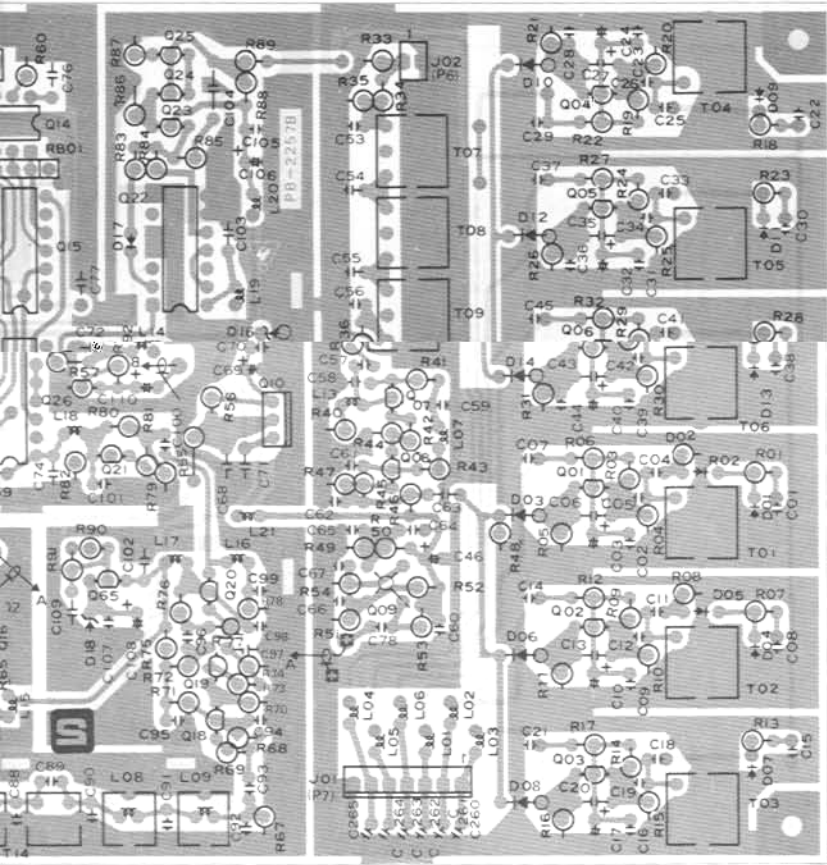

Viewed from component side

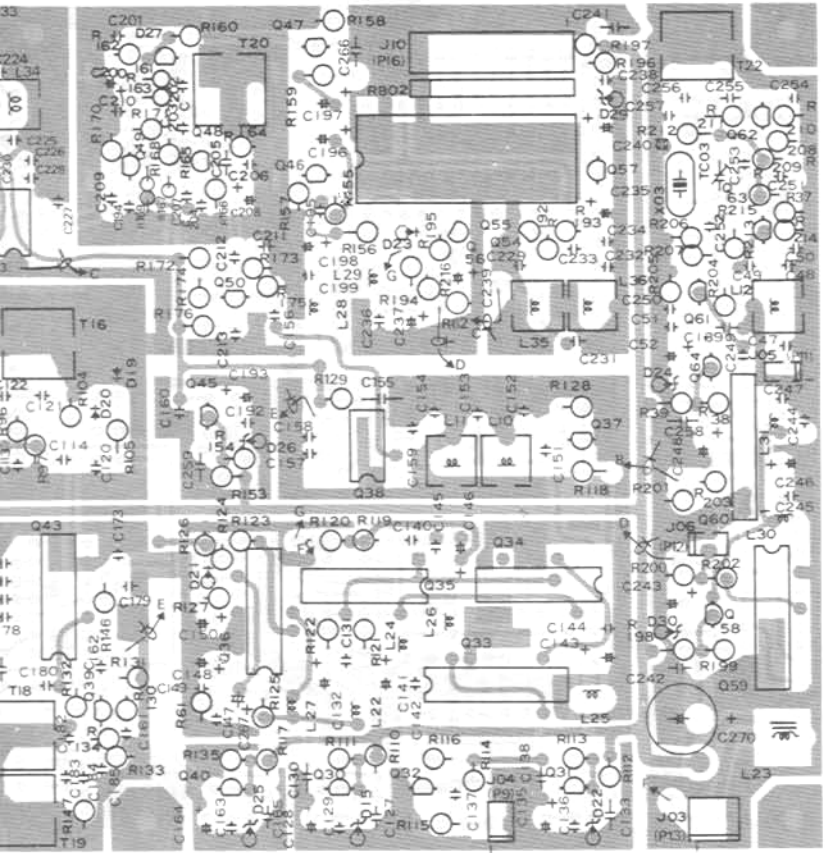

Viewed from solder side

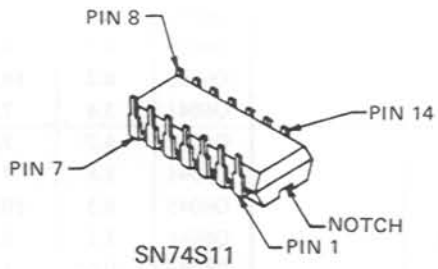
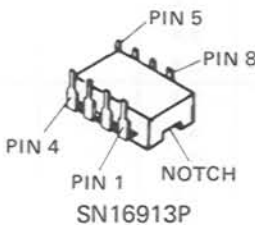
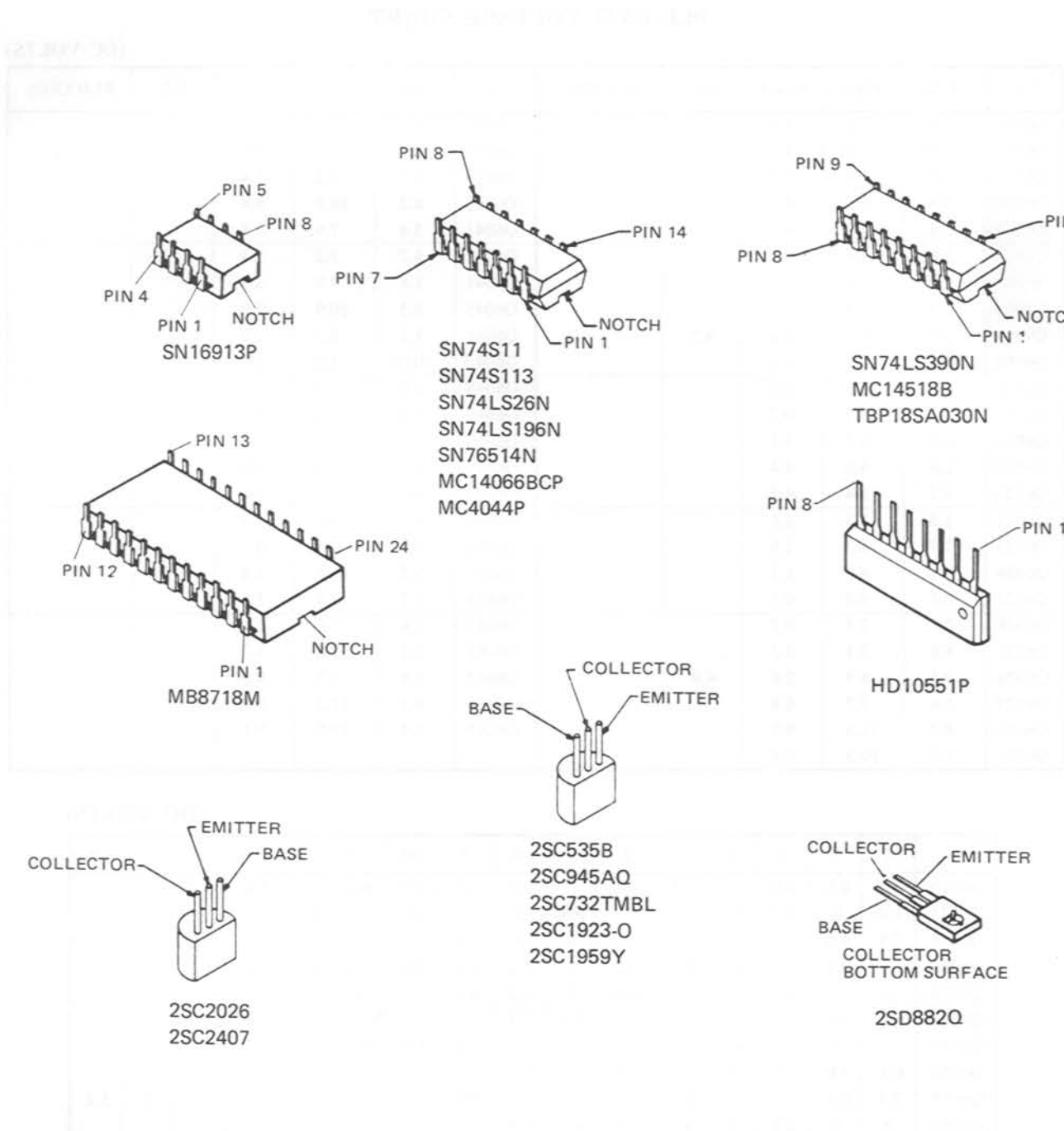

- SN74S11
- SN74S113
- SN74LS26N
- SN74LS196N
- SN76514N
- MC14066BCP
- MC4044P

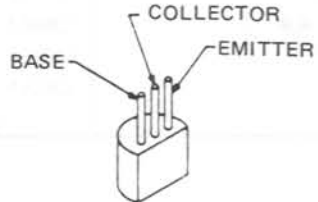
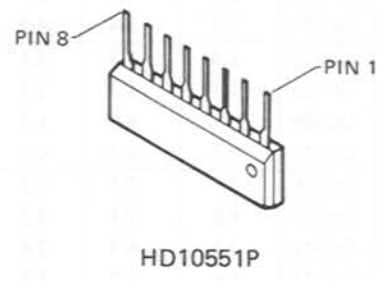
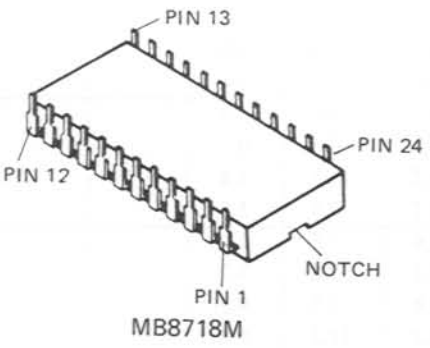
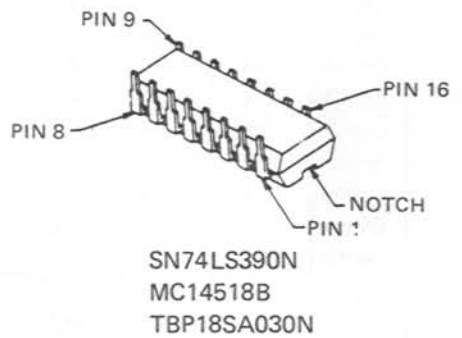

- 2SC535B
- 2SC945AQ
- 2SC732TMBL
- 2SC1923-O
- 2SC1959Y

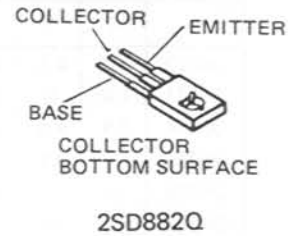
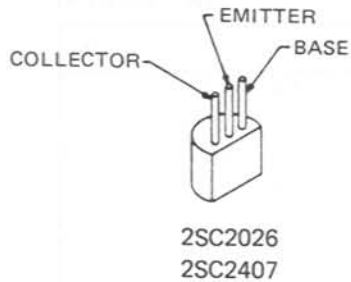

PLL UNIT VOLTAGE CHART

(DC VOLTS)

	E(S)	C(D)	B(G1)	G2	REMARKS		E(S)	C(D)	B(G1)	G2	REMARKS
Q6001	3.8	7.6	4.1			Q6032	0	1.0	0.7		
Q6002	3.8	7.6	4.1			Q6037	0	2.2	0.6		
Q6003	3.8	7.6	4.1			Q6039	4.7	7.2	5.4		
Q6004	3.8	7.6	4.1			Q6040	8.2	10.8	8.8		
Q6005	3.8	7.6	4.1			Q6041	5.4	7.9	3.9		
Q6006	3.8	7.6	4.1			Q6042	4.7	7.2	5.4		
Q6007	1.0	7.2	1.8			Q6044	1.8	7.8	2.5		
Q6008	1.8	7.4	2.5			Q6045	8.3	10.9	9.0		
Q6009	2.5	5.1	2.6	4.8		Q6046	1.1	8.3	1.6		
Q6010	5.4	10.7	6.0			Q6047	0.02	5.6	1.1		
Q6016	0	6.5	0.7			Q6048	4.0	7.8	4.7		
Q6017	0	6.5	0.7			Q6049	3.4	7.8	2.7		
Q6018	2.4	6.5	3.1			Q6050	1.9	8.0	2.5		
Q6019	1.6	4.0	2.4			Q6051	3.3	7.9	3.8		
Q6020	3.3	8.4	4.2			Q6052	4.6	7.2	5.4		
Q6021	1.5	5.3	1.8			Q6054	0	2.0	0.5		
Q6023	1.1	8.3	1.6			Q6056	0	3.1	0		
Q6024	0.7	4.9	1.1			Q6057	5.2	11.3	5.8		
Q6025	0.1	4.9	0.7			Q6058	5.2	7.9	5.9		
Q6026	0	2.8	0.2			Q6061	1.6	7.8	1.0		
Q6027	4.6	7.1	5.3			Q6062	3.5	7.8	3.7		
Q6028	2.5	6.9	2.6	4.8		Q6063	1.8	7.7	0.9		
Q6029	4.6	7.7	4.8			Q6064	8.2	11.3	8.8		
Q6030	8.2	11.3	9.0			Q6065	8.4	10.5	9.1		
Q6031	5.2	10.3	5.8								

(DC VOLTS)

	1	2	3	4	5	6	7	8	9	10	11	12	13	14	15	16
Q6022	2.8	4.3	4.0	0	0	-	0	0	0	1.7	4.4	-	4.4	5.3		
Q6033	1.0	0	1.7	1.7	-	-	0.8	0	-	1.7	-	2.1	2.1	0	0.8	5.1
Q6034	2.9	4.0	1.7	0	0	-	0	0	0	-	5.1	-	0.5	5.1		
Q6035	4.0	0.5	2.7	2.7	2.7	0.2	0	0.2	4.0	4.0	6.9	0.5	0.5	5.2		
Q6036	0	-	4.1	4.0	0.2	6.9	0	4.2	4.2	-	0	0	0	8.3		
Q6038	6.1	3.6	2.6	0	2.6	3.6	3.6	7.3								
Q6043	-	7.9	7.1	4.0	4.0	0	-	-	2.6	4.0	4.0	4.0	7.1	-		
Q6053	6.1	3.6	2.6	0	2.6	3.6	3.6	7.3								
Q6059	2.0	5.2	-	-	2.1	-	0	0	2.1	5.2	-	-	2.1	-	0	5.2
Q6060	0	0	2.0	0	4.9	0	4.9	2.8								

	1	2	3	4	5	6	7	8	9	10	11	12	13	14	15	16
Q6055	0	1.6	0	5.2	3.1	-	0	-	0	-	2.0	5.2	5.5/0	5.5/0	5.5/0	5.5/0
17	18	19	20	21	22	23	24	REMARKS								
5.5/0	5.5/0	5.5/0	5.5/0	0	5.2	0	-	DATA High/Low								

PLL UNIT COMPONENT APPLICATIONS

Q6001	2SC1923-O	Transistor	PLL VCO-4-6	Q6051	2SC535B	"	PLL Local Oscillator
Q6002	"	"	PLL VCO-4-5	Q6052	2SC945AQ	"	PLL Local Buffer Amplifier
Q6003	"	"	PLL VCO-4-4				
Q6004	"	"	PLL VCO-4-1	Q6053	SN16913P	IC	PLL Mixer
Q6005	"	"	PLL VCO-4-2	Q6054	2SC945AQ	Transistor	PLL IF Amplifier
Q6006	"	"	PLL VCO-4-3	Q6055	MB8718B	IC	PLL Divider, Phase Detector
Q6007	2SC2026	"	PLL VCO-4 Buffer Amplifier	Q6056	2SC945AQ	Transistor	PLL Reference Amplifier
Q6008	2SC1923-O	"	"	Q6057	"	"	Regulator
Q6009	3SK74L	Dual Gate MOS FET	"	Q6058	2SC1959Y	"	"
Q6010	2SD882Q	Transistor	Regulator	Q6059	MC14518B	IC	PLL Reference
Q6011	SN74S113	IC	PLL Programmable Divider	Q6060	HD10551	"	1/100 Divider
Q6012	SN74S11	"	"				1/20 Divider
Q6013	SN74LS196	"	"	Q6061	JF1033B	Junction FET	PLL Reference Buffer Amplifier
Q6014	TBP18SA030	"	PLL ROM	Q6062	2SC535B	Transistor	PLL Reference Oscillator
Q6015	SN74LS196	"	PLL Programmable Divider	Q6063	JF1033B	Junction FET	PLL Reference Buffer Amplifier
Q6016	2SK206-3	Junction FET	PLL Mixer	Q6064	2SC945AQ	Transistor	Regulator
Q6017	"	"	"	Q6065	2SC1959Y	"	"
Q6018	2SC1923-O	Transistor	PLL Buffer Amplifier	D6001	1T25	Varactor Diode	PLL VCO-4-6
Q6019	2SC2026	"	PLL IF Amplifier	D6002	"	"	"
Q6020	2SC1923-O	"	PLL Buffer Amplifier	D6003	1SS53	Si Diode	Switch
Q6021	2SC2407	"	"	D6004	1T25	Varactor Diode	PLL VCO-4-5
Q6022	MC4044P	IC	PLL Phase Detector				
Q6023	2SC732TMBL	Transistor	PLL Active LPF				
Q6024	"	"	"	D6005	"	"	"
Q6025	"	"	"	D6006	1SS53	Si Diode	Switch
Q6026	2SC945AQ	"	PLL Reference Amplifier	D6007	1T25	Varactor Diode	PLL VCO-4-4
Q6027	"	"	PLL VCO-3 Buffer Amplifier	D6008	1SS53	Si Diode	Switch
Q6028	3SK74L	Dual Gate MOS FET	PLL VCO-3 Amplifier	D6009	1T25	Varactor Diode	PLL VCO-4-1
Q6029	2SC1923-O	Transistor	PLL VCO-3	D6010	1SS53	Si Diode	Switch
Q6030	2SC945AQ	"	Regulator	D6011	1T25	Varactor Diode	PLL VCO-4-2
Q6031	2SC1959Y	"	"	D6012	1SS53	Si Diode	Switch
Q6032	2SC1923-O	"	PLL VCO-1 Amplifier	D6013	1T25	Varactor Diode	PLL VCO-4-3
Q6033	SN74LS390	IC	PLL VCO-1 1/100 Divider	D6014	1SS53	Si Diode	Switch
Q6034	MC4044P	"	PLL Phase Detector	D6015	RD9.1EB2	Zener Diode	Regulator
Q6035	SN74LS26	"	PLL Inverter	D6016	RD5.6EB3	"	"
Q6036	MC14066BCP	"	PLL Switch	D6017	1SS97	Schottky Barrier Di.	Switch
Q6037	2SC945AQ	Transistor	PLL Buffer Amplifier	D6018	RD9.1EB2	Zener Diode	Regulator
Q6038	SN16913P	IC	PLL Mixer	D6019	1T25	Varactor Diode	PLL VCO-3
Q6039	2SC945AQ	Transistor	PLL Buffer Amplifier	D6020	"	"	"
Q6040	2SC1959Y	"	Regulator	D6021	1SS53	Si Diode	Switch
Q6041	2SC535B	"	PLL Local Oscillator	D6022	RD5.6EB3	Zener Diode	Regulator
Q6042	2SC945AQ	"	PLL Local Buffer Amplifier	D6023	1N60	Ge Diode	Switch
Q6043	SN76514N	IC	PLL Mixer	D6024	RD9.1EB2	Zener Diode	Regulator
Q6044	2SC945AQ	Transistor	PLL Local Buffer Amplifier	D6025	"	"	"
Q6045	2SC1959Y	"	Regulator	D6026	"	"	"
Q6046	2SC732TMBL	"	PLL Active LPF	D6027	MV104	Varactor Diode	PLL VCO-2
Q6047	MPS-A13	"	"				
Q6048	2SC1923-O	"	PLL VCO-2	D6028	1T25	"	D/F Converter
Q6049	2SK19TMGR	Junction FET	PLL VCO-2 Buffer Amplifier	D6029	RD5.6EB3	Zener Diode	Regulator
Q6050	2SC945AQ	Transistor	"	D6030	"	"	"
				X6001	48.615MHz	Crystal	PLL Local Oscillator
				X6002	54.28MHz	"	"
				X6003	20MHz	"	PLL Reference Oscillator

100W PA UNIT

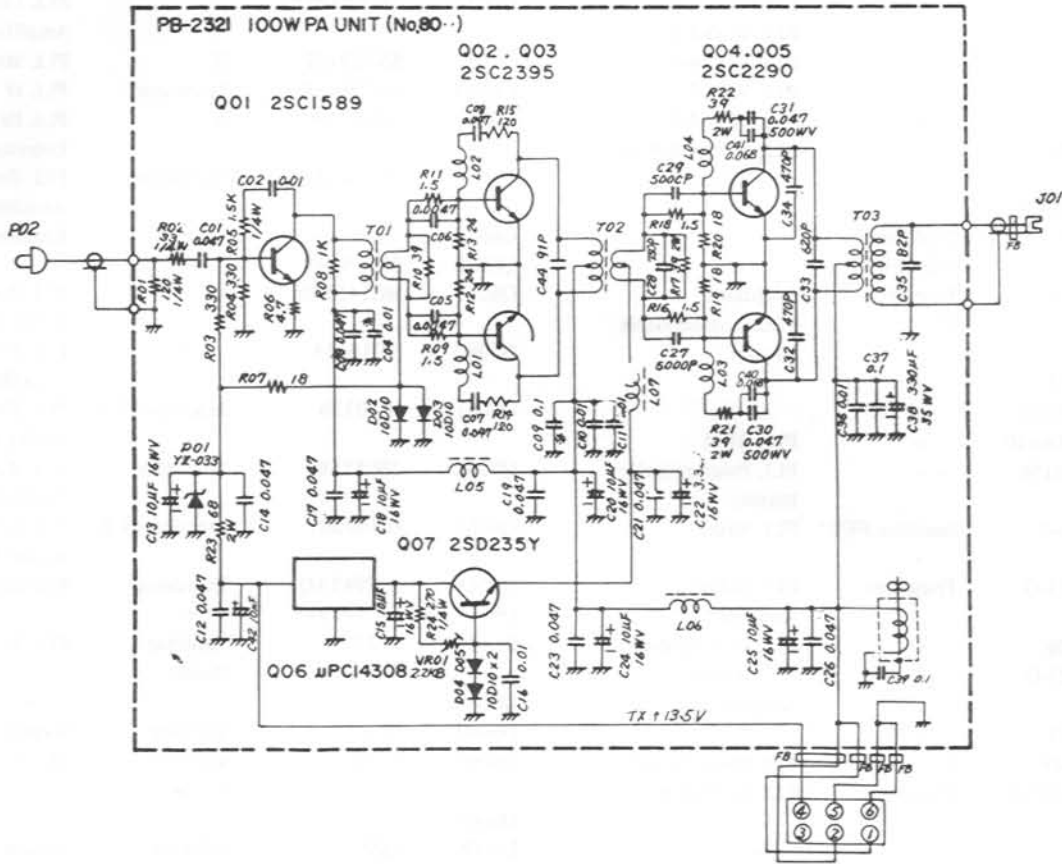

VOLTAGE CHART
(DC VOLTS)

	E	C	B	REMARKS
Q8001	0.5	13.5	1.3	TX
Q8002	0	13.5	0.7	TX
Q8003	0	13.5	0.7	TX
Q8004	0	13.5	0.7	TX
Q8005	0	13.5	0.7	TX
Q8007	0.7	8.0	1.3	TX

	IN	OUT	REMARKS
Q8006	13.5	8.0	TX

COMPONENT APPLICATIONS

Q8001	2SC1589	Transistor	TX Driver Amplifier
Q8002	2SC2395	"	"
Q8003	"	"	"
Q8004	2SC2290	"	TX Final Amplifier
Q8005	"	"	"
Q8006	μPC14308	IC	Regulator
Q8007	2SD235Y	Transistor	"
D8001	YZ-033	Zener Diode	Regulator
D8002	10D10	Si Diode	Temperature Compensator
D8003	"	"	"
D8004	"	"	"
D8005	"	"	"

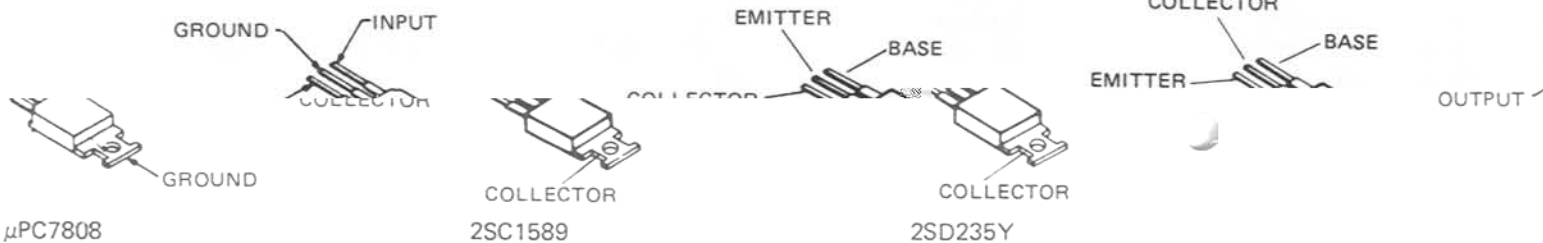
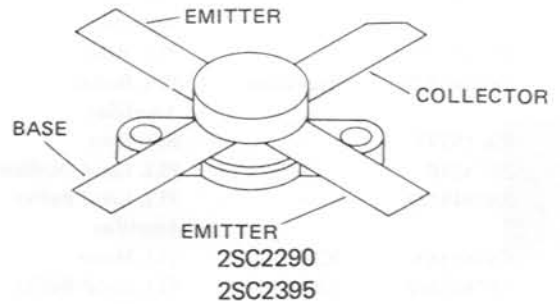

100W PA UNIT PARTS LAYOUT

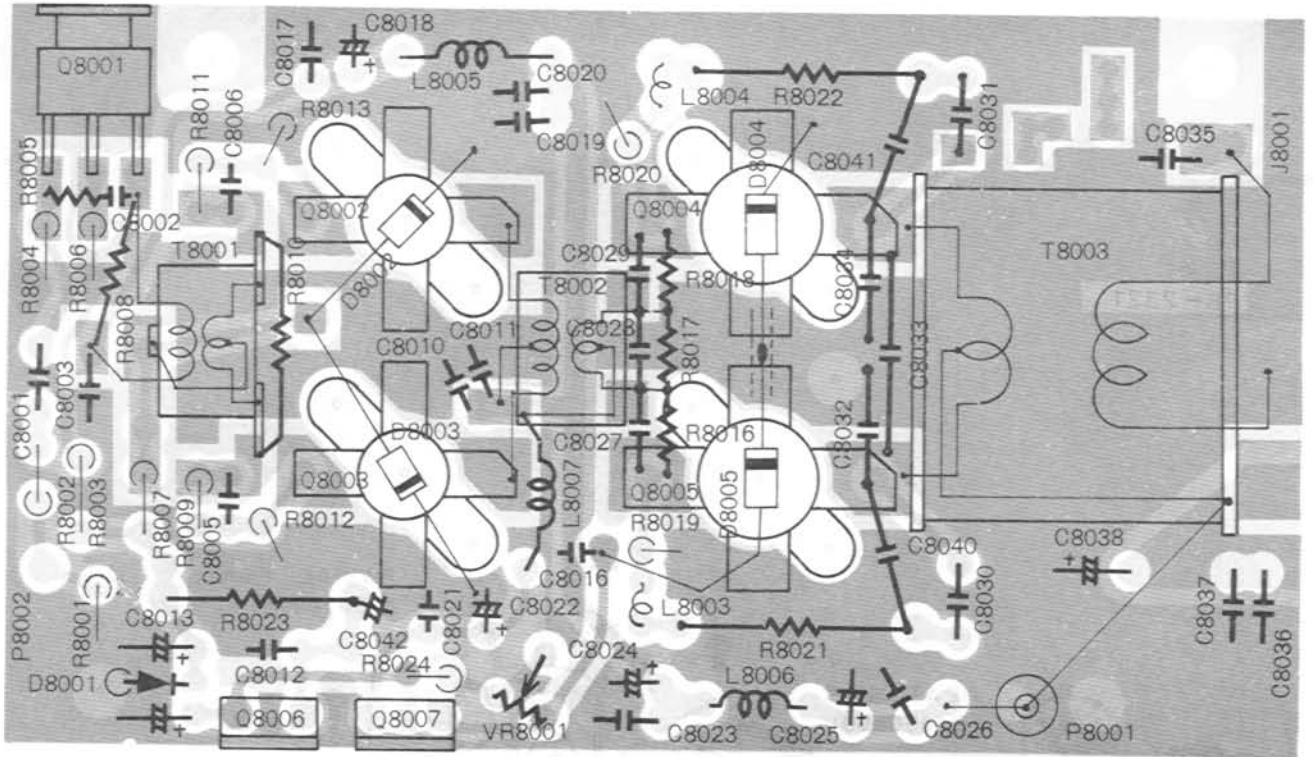

Viewed from component side

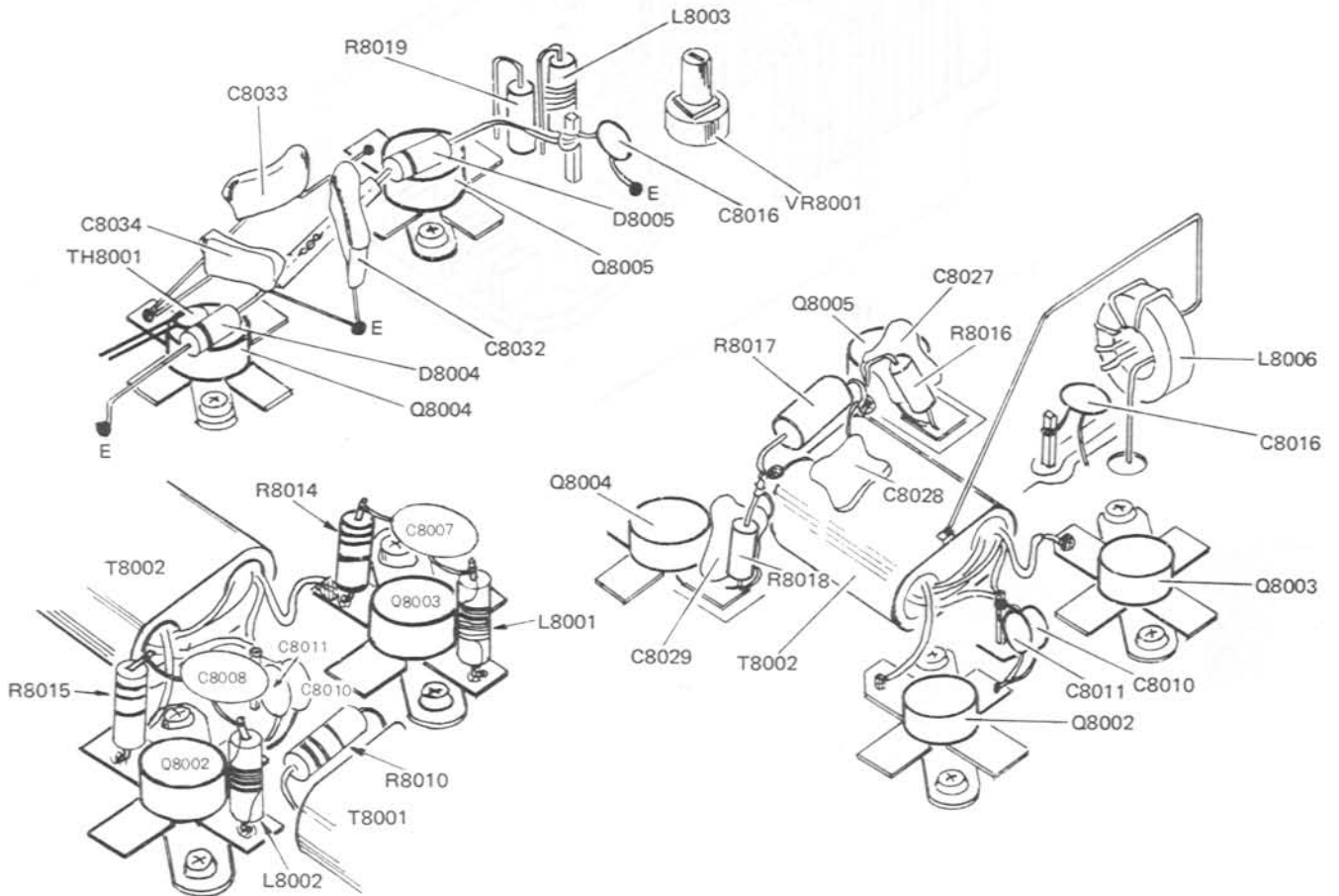

COOLING FAN MOUNTING DETAIL

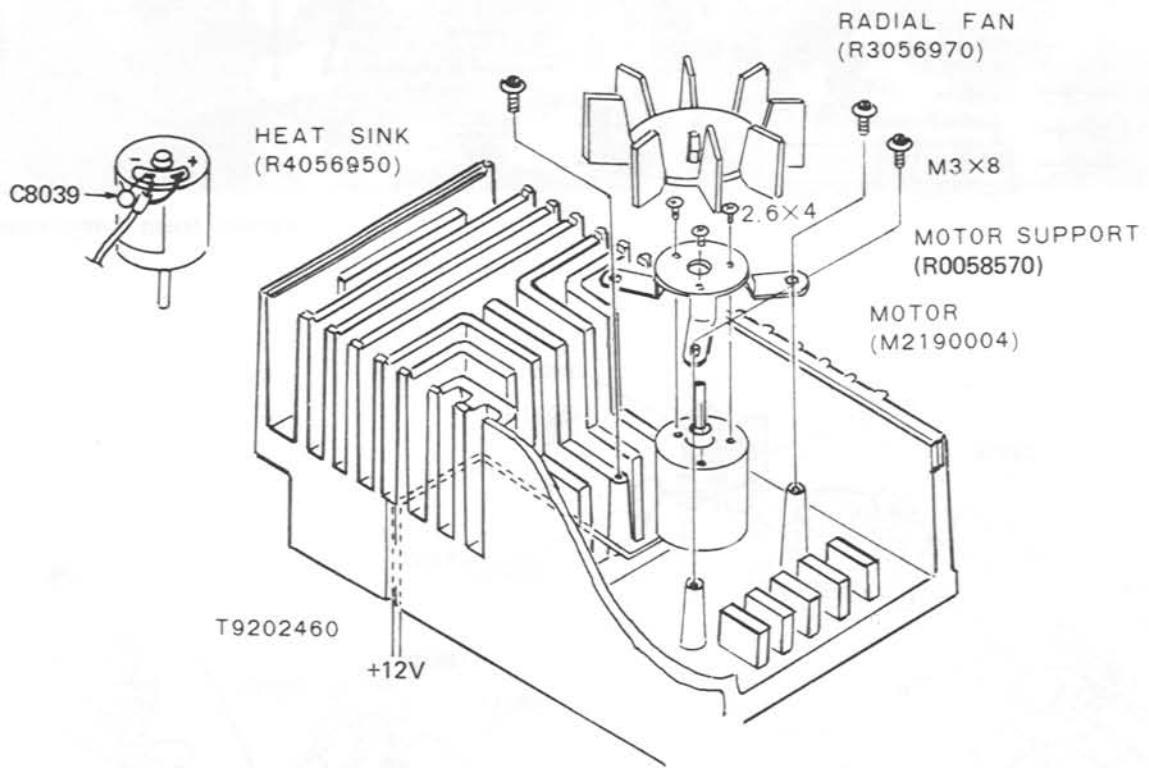

DIODE SW UNIT PARTS LAYOUT

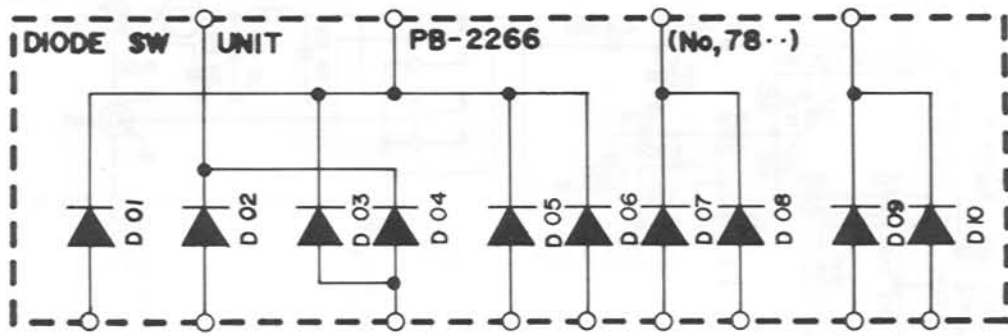

COMPONENT APPLICATIONS

Part No.	Code	Material	Function
D7801	V06B	Si Diode	Switch
D7802	"	"	"
D7803	"	"	"
D7804	"	"	"
D7805	"	"	"
D7806	"	"	"
D7807	"	"	"
D7808	"	"	"
D7809	"	"	"
D7810	"	"	"

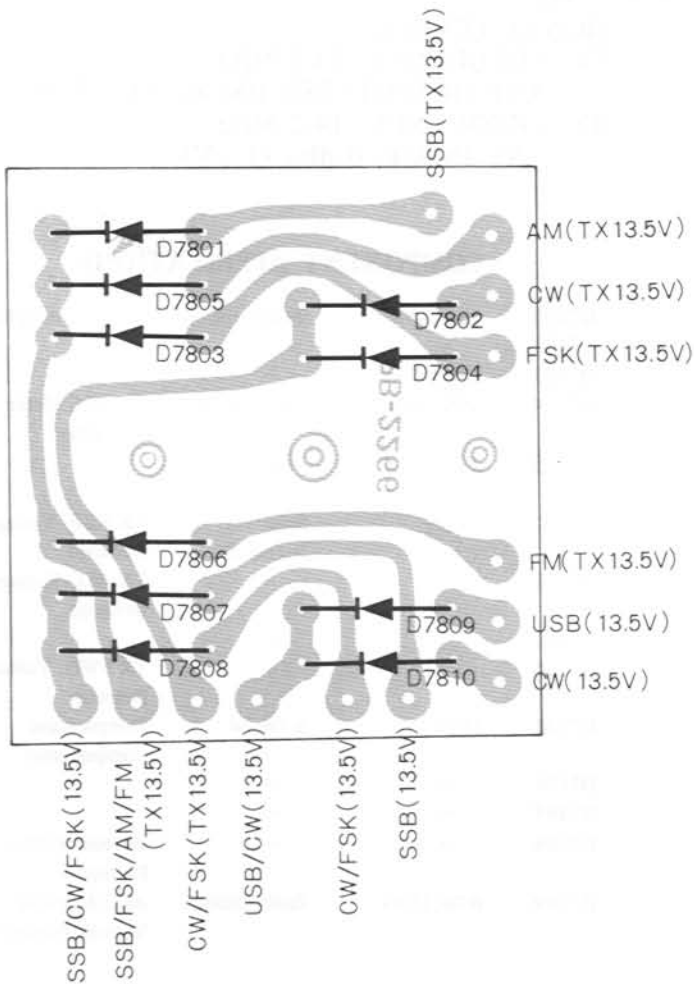

Viewed from component side

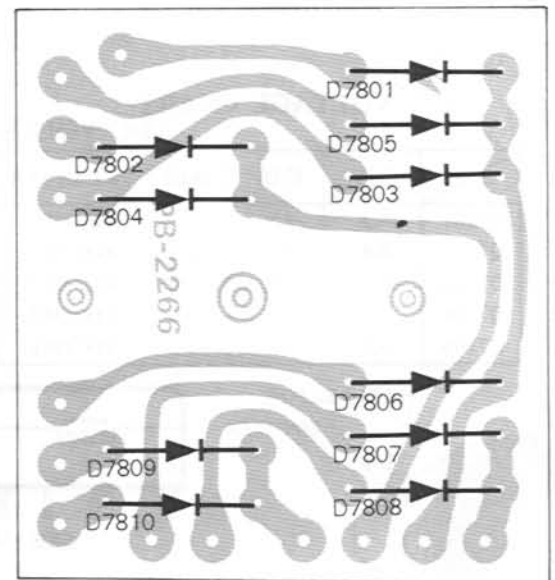

Viewed from foil side

ALC UNIT

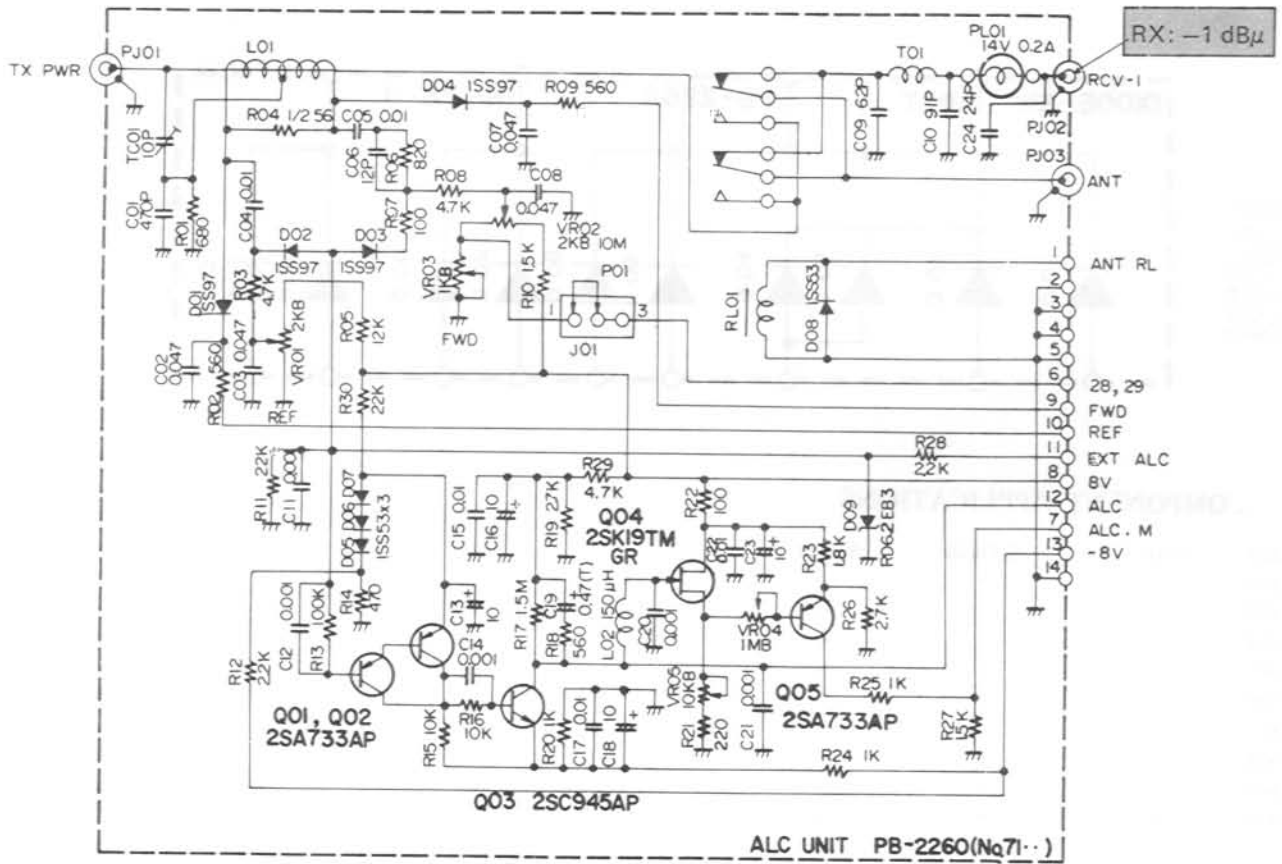

ALC UNIT

SIGNAL LEVELS

TX: FREQUENCY; 14.2 MHz
 ANT OUTPUT; SSB 100 W, AM 25 W
 RX: FREQUENCY; 14.2 MHz
 ANT INPUT; 0 dBμ (1 μV)

VOLTAGE CHART (DC VOLTS)

	E(S)	C(D)	B(G)	REMARKS
Q7101	0.3	-4.0	0	ALC OFF
Q7102	0.8	-4.0	0.3	ALC OFF
Q7103	-4.0	2.6	-4.0	ALC OFF
Q7104	4.4	7.6	2.6	ALC OFF
Q7105	4.9	0	4.3	ALC OFF

COMPONENT APPLICATIONS

Q7101	2SA733AP	Transistor	TX ALC Amplifier
Q7102	"	"	"
Q7103	2SC945AP	"	"
Q7104	2SK19TMGR	Junction FET	TX ALC Meter Amplifier
Q7105	2SA733AP	Transistor	"
D7101	1SS97	Schottky Barrier Di.	TX REF. Voltage Detector
D7102	"	"	TX ALC Voltage Detector
D7103	"	"	"
D7104	"	"	TX FWD. Voltage Detector
D7105	1SS53	Si Diode	Temperature Compensator
D7106	"	"	"
D7107	"	"	"
D7108	"	"	Reverse Voltage Protector
D7109	RD6.2EB3	Zener Diode	ALC Amplifier Voltage Protector

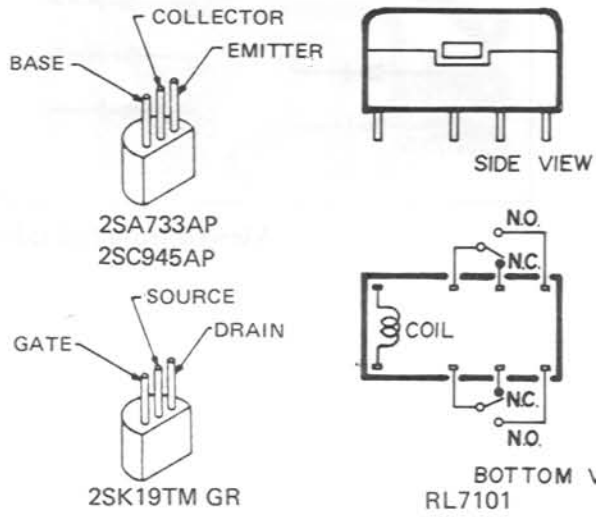

ALC UNIT PARTS LAYOUT

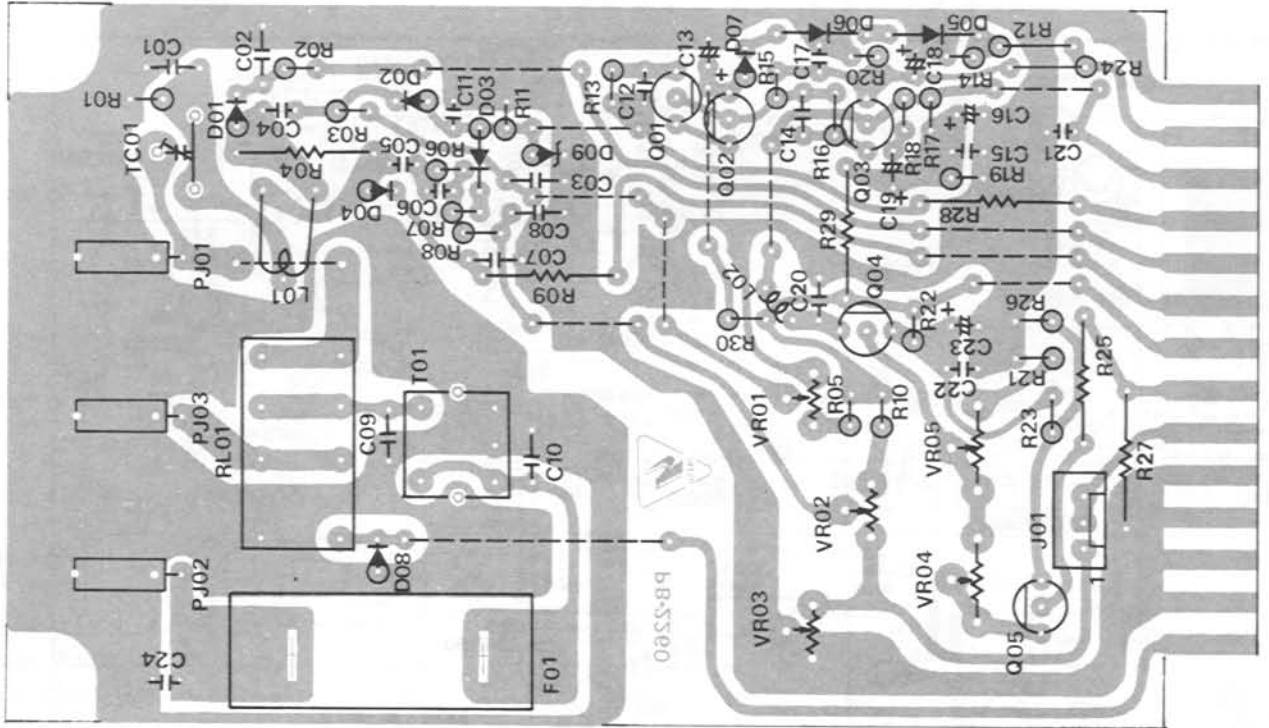

Viewed from component side

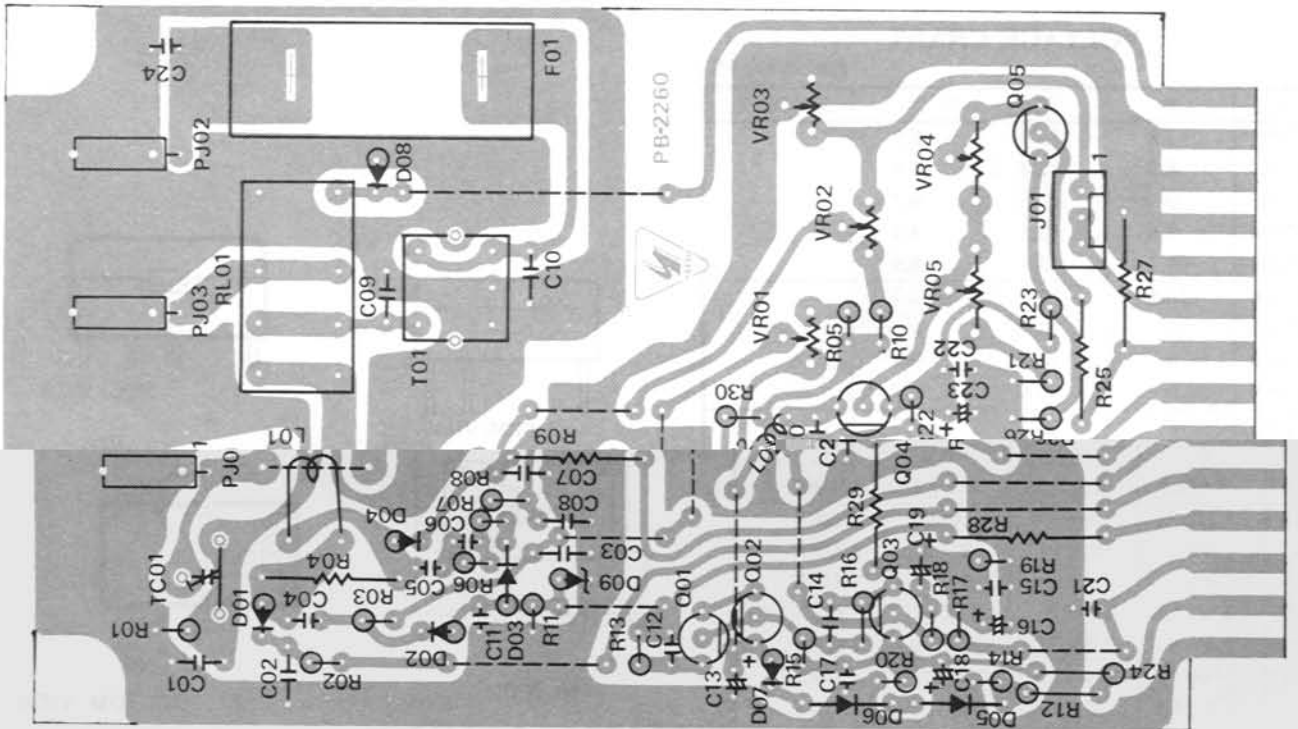

Viewed from solder side

REG UNIT

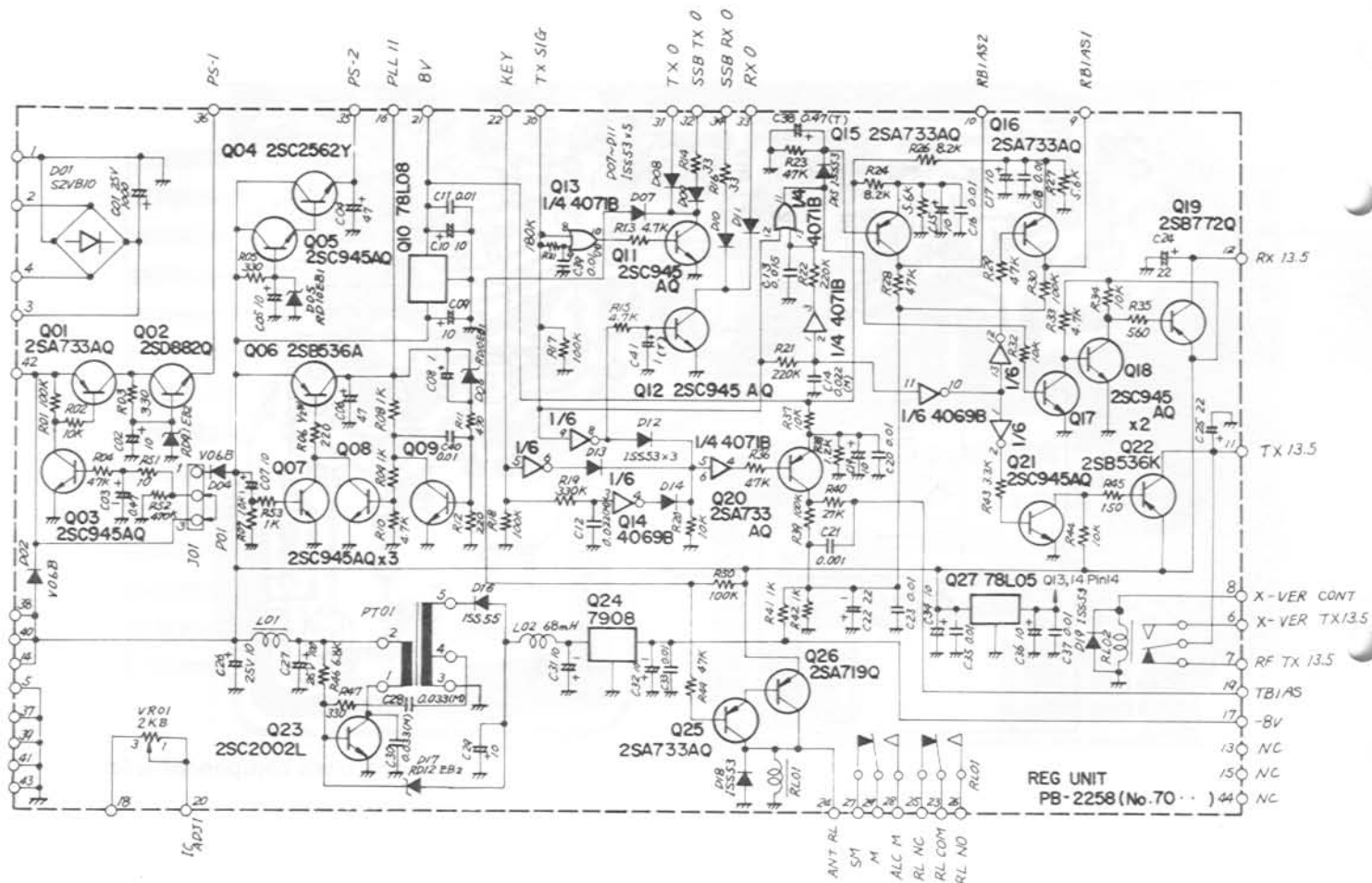

VOLTAGE CHART

(DC VOLTS)

	E	C	B	REMARKS
Q7001	12.8	12.0	12.0	
Q7002	8.2	12.0	8.8	
Q7003	0	0	0.7	
Q7004	7.6	13.5	8.2	
Q7005	8.2	13.5	8.9	
Q7006	13.5	11.6	12.7	
Q7007	0	10.9	0	
Q7008	0	10.9	0.3	
Q7009	0	0.4	0.7	
Q7011	0	0	0.7	
Q7012	0	0	0.8	
Q7015	-4.0/2.7	3.3/2.7	4.2/2.1	TX/RX
Q7016	3.3/2.9	-3.9/2.9	5.0/2.4	TX/RX
Q7017	0/0	0/0.8	0.7/0	TX/RX
Q7018	0/0	13.5/0	0/0.8	TX/RX
Q7019	13.5/13.5	0/13.5	13.5/0	TX/RX
Q7020	0.8/0.9	0.8/-3.9	0.3/5.0	TX/RX
Q7021	0/0	0.4/13.5	0.8/0	TX/RX
Q7022	13.5/13.5	13.5/0	0.4/13.5	TX/RX
Q7023	0	13.5	0	
Q7025	12.7/12.9	12.6/0	12.0/13.3	TX/RX
Q7026	13.5/13.5	12.6/0	12.7/12.9	TX/RX

	IN	OUT	REMARKS
Q7010	13.5	8.3	
Q7024	-9.1	-8.1	
Q7027	13.5	5.0	

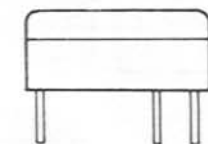

SIDE VIEW

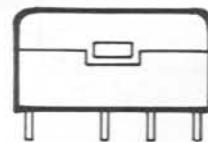

SIDE VIEW

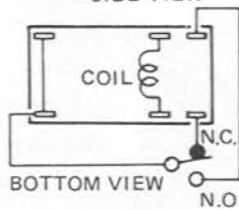

RL7002

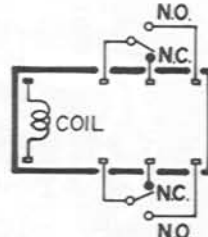

RL7001

REG UNIT PARTS LAYOUT

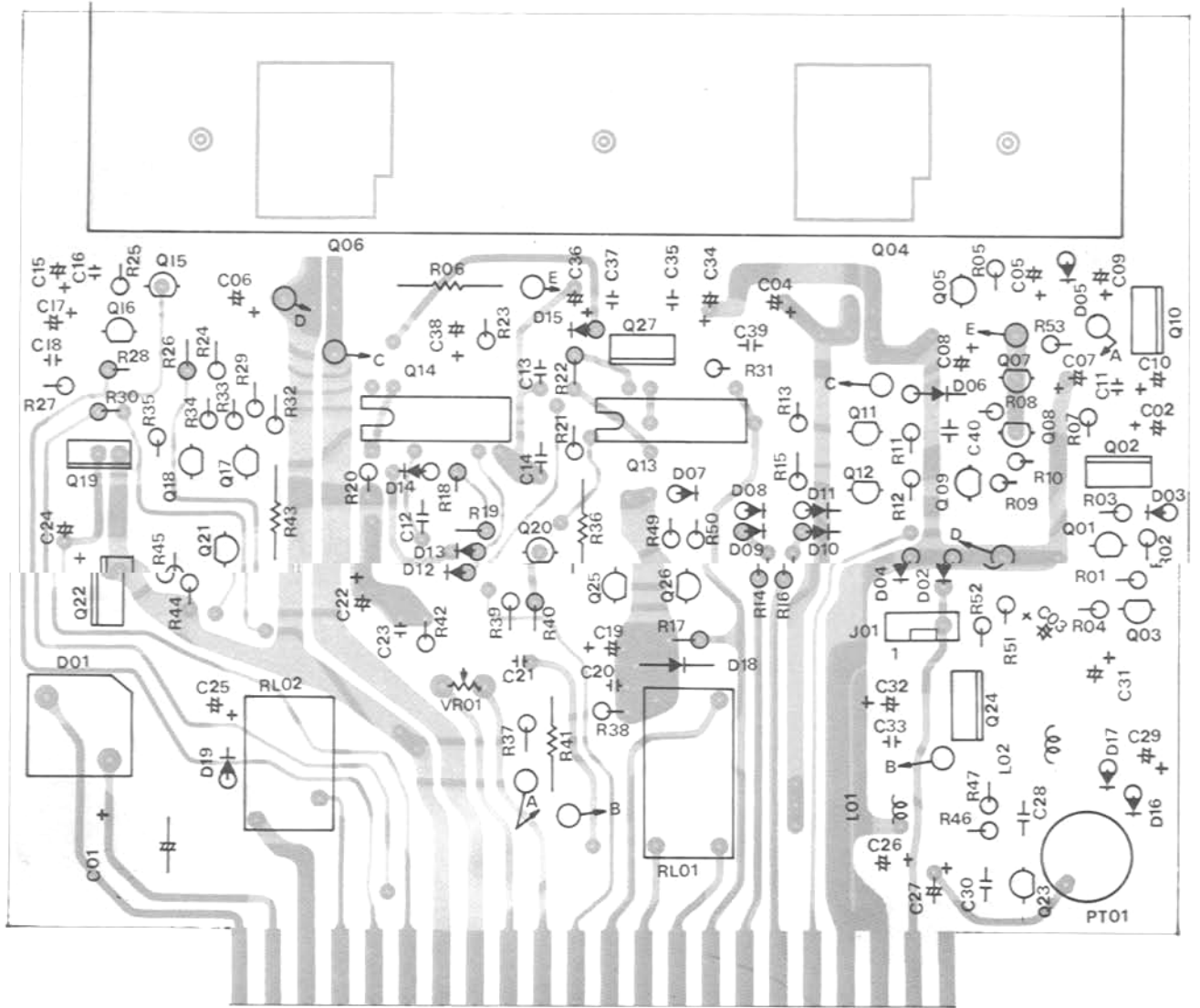

Viewed from component side

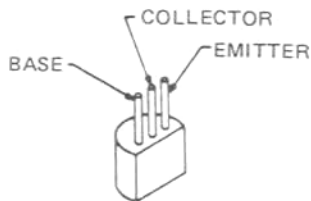

- 2SA733AQ
- 2SA719Q
- 2SC945AQ
- 2SC2002L

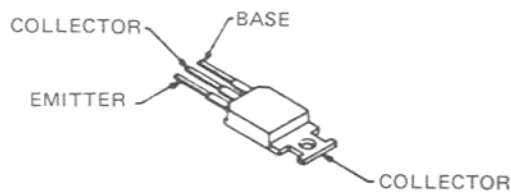

- 2SB536K
- 2SC2562Y

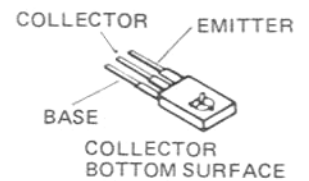

- COLLECTOR BOTTOM SURFACE
- 2SB772Q
- 2SD882Q

REG UNIT PARTS LAYOUT

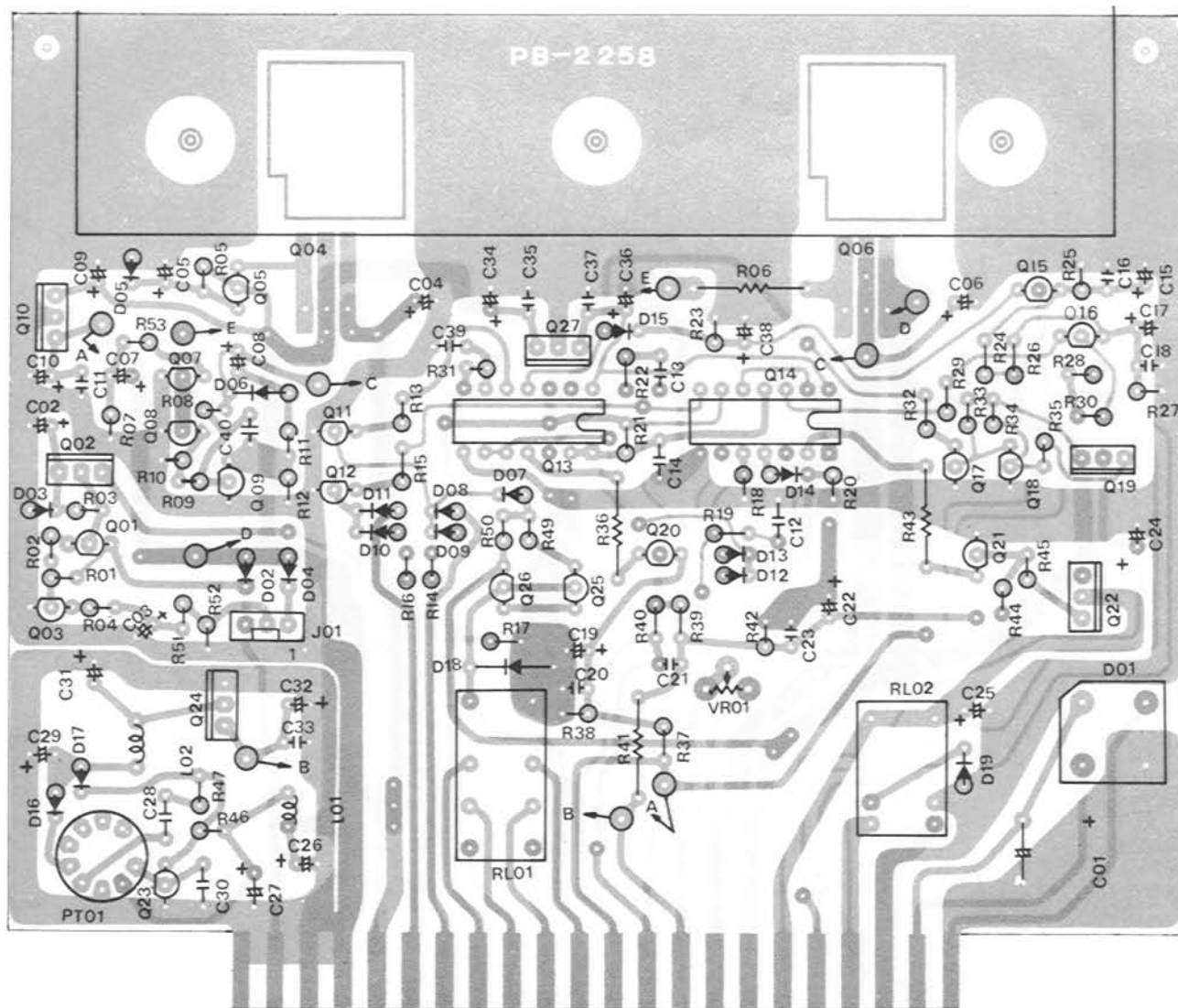

Viewed from solder side

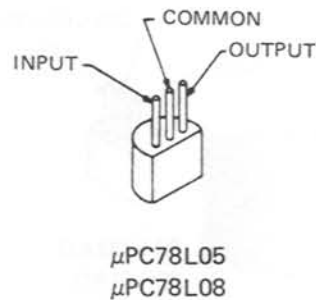
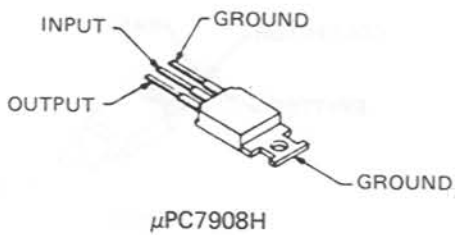
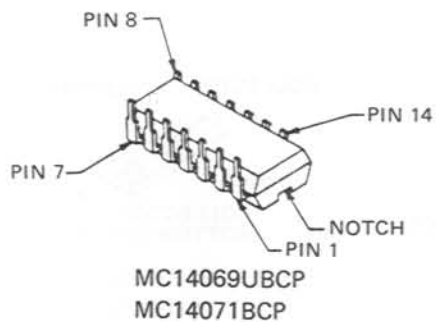

REGULATOR UNIT COMPONENT APPLICATIONS

Q7001	2SA733AQ	Transistor	Switch
Q7002	2SD882Q	"	Regulator
Q7003	2SC945AQ	"	Switch Driver
Q7004	2SC2562Y	"	Regulator
Q7005	2SC945AQ	"	"
Q7006	2SB536A	"	"
Q7007	2SC945AQ	"	Switch
Q7008	"	"	Error Amplifier
Q7009	"	"	"
Q7010	78L08	IC	Regulator
Q7011	2SC945AQ	Transistor	Switch
Q7012	"	"	"
Q7013	MC14071B	IC	Delay Amplifier, Buffer Amp.
Q7014	MC14069B	"	Delay Amplifier
Q7015	2SA733AQ	Transistor	Switch
Q7016	"	"	"
Q7017	2SC945AQ	"	Switch Driver
Q7018	"	"	"
Q7019	2SB772Q	"	Switch
Q7020	2SA733AQ	"	"
Q7021	2SC945AQ	"	Switch Driver
Q7022	2SB536K	"	Switch
Q7023	2SC2002L	"	DC-DC Converter
Q7024	μPC7908	IC	Regulator
Q7025	2SA733AQ	Transistor	Relay Driver
Q7026	2SA719Q	"	"
Q7027	78L05	IC	Regulator
D7001	S2VB10	Si Diode Bridge	Rectifier
D7002	V06B	Si Diode	Switch
D7003	RD9.1EB2	Zener Diode	Regulator
D7004	V06B	Si Diode	Switch
D7005	RD9.1EB2	Zener Diode	Regulator
D7006	RD10EB1	"	"
D7007	1SS53	Si Diode	Switch
D7008	"	"	"
D7009	"	"	"
D7010	"	"	"
D7011	"	"	"
D7012	"	"	"
D7013	"	"	"
D7014	"	"	"
D7015	"	"	"
D7016	"	"	Rectifier
D7017	RD12EB2	Zener Diode	Regulator
D7018	1SS53	Si Diode	Reverse Voltage Protector
D7019	"	"	"

LPF UNIT

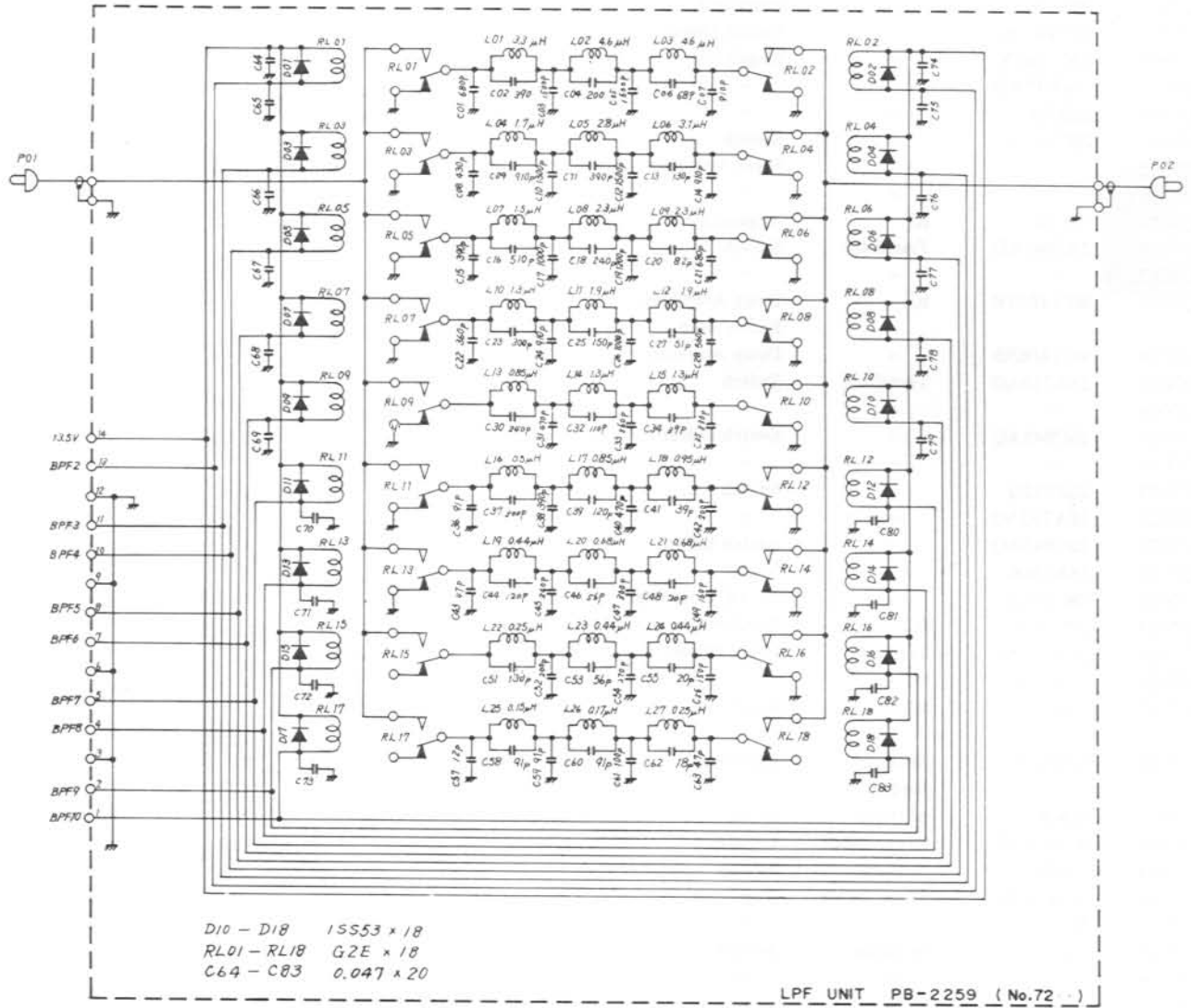

COMPONENT APPLICATIONS

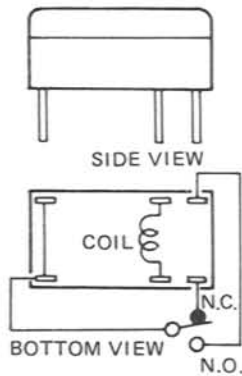

RL7201-7218

Part Number	1SS53	Si Diode	Reverse Voltage Protector
D7201			
D7202	"	"	"
D7203	"	"	"
D7204	"	"	"
D7205	"	"	"
D7206	"	"	"
D7207	"	"	"
D7208	"	"	"
D7209	"	"	"
D7210	"	"	"
D7211	"	"	"
D7212	"	"	"
D7213	"	"	"
D7214	"	"	"
D7215	"	"	"
D7216	"	"	"
D7217	"	"	"
D7218	"	"	"

LPF UNIT PARTS LAYOUT

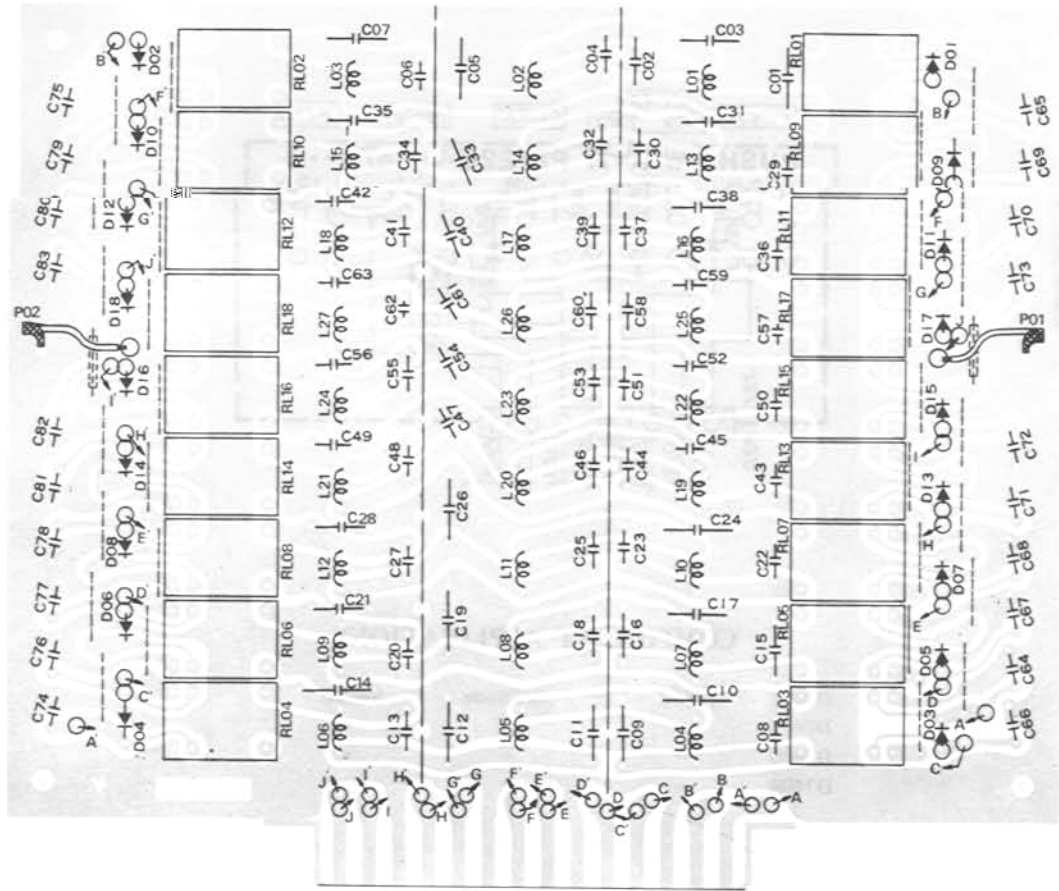

Viewed from component side

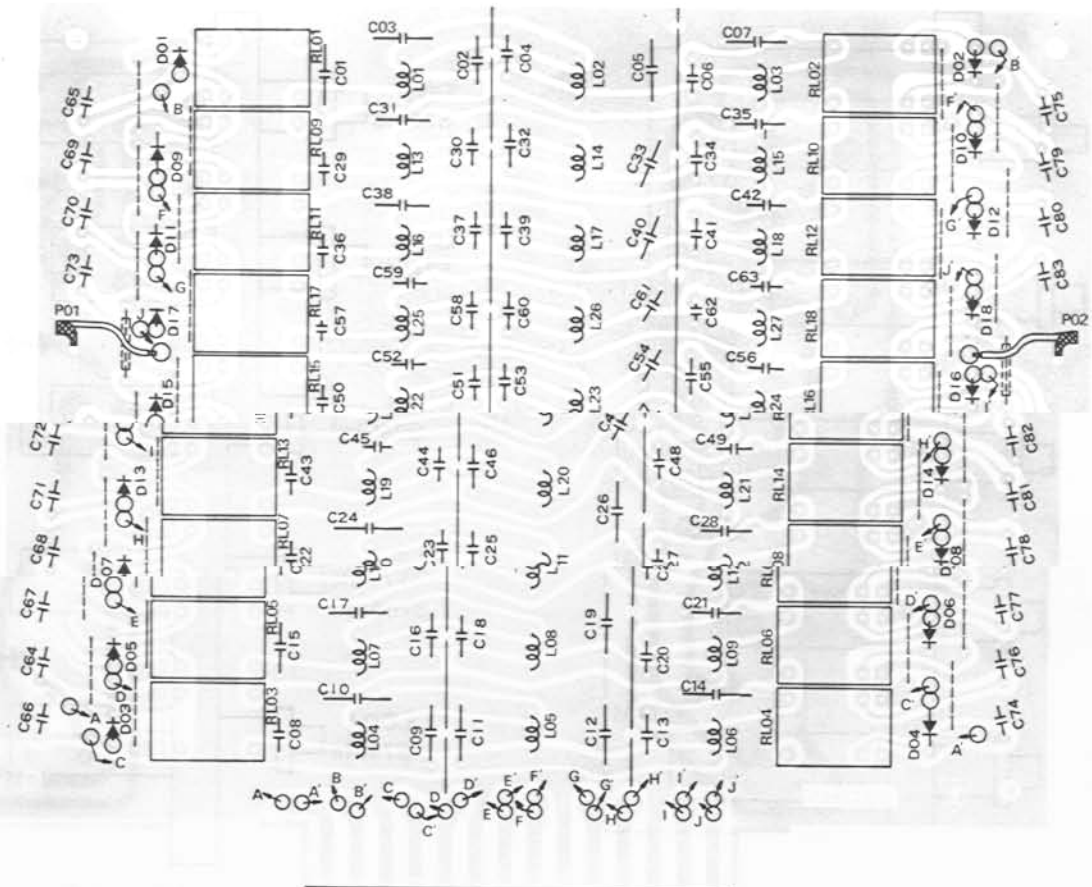

Viewed from solder side

PUSH SW UNIT

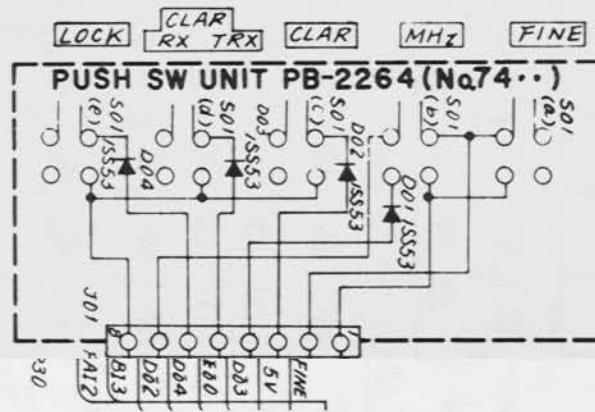

COMPONENT APPLICATIONS

Part No.	Part Name	Material	Notes
D7401	1SS53	Si Diode	Switch
D7402	"	"	"
D7403	"	"	"
D7404	"	"	"

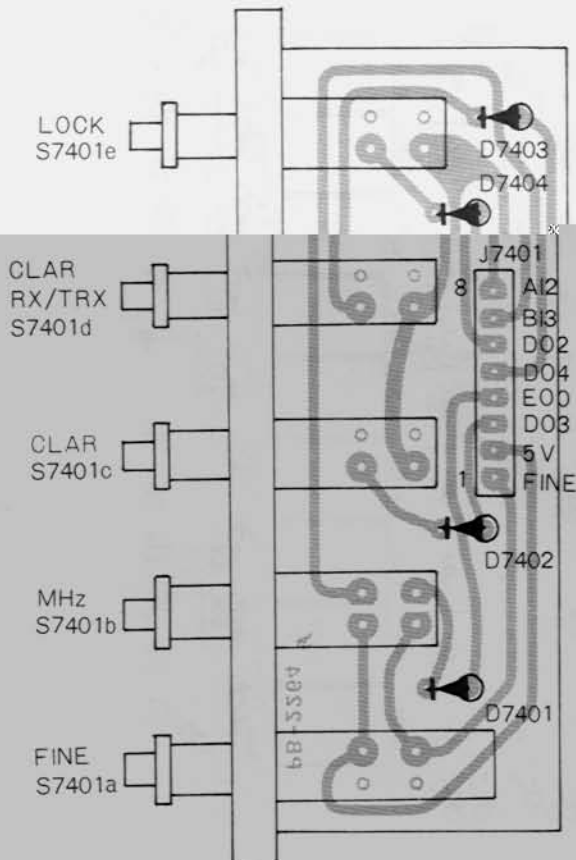

Viewed from component side

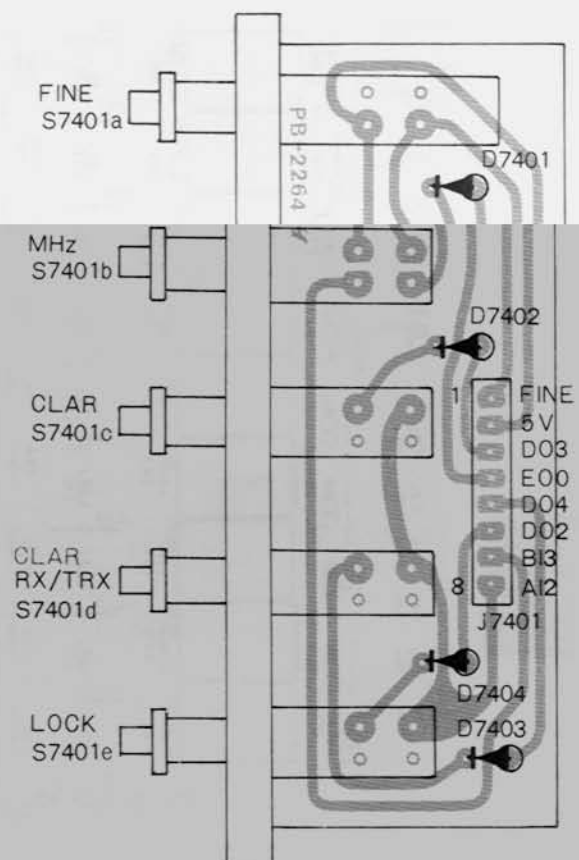

Viewed from solder side

LEVER SW UNIT

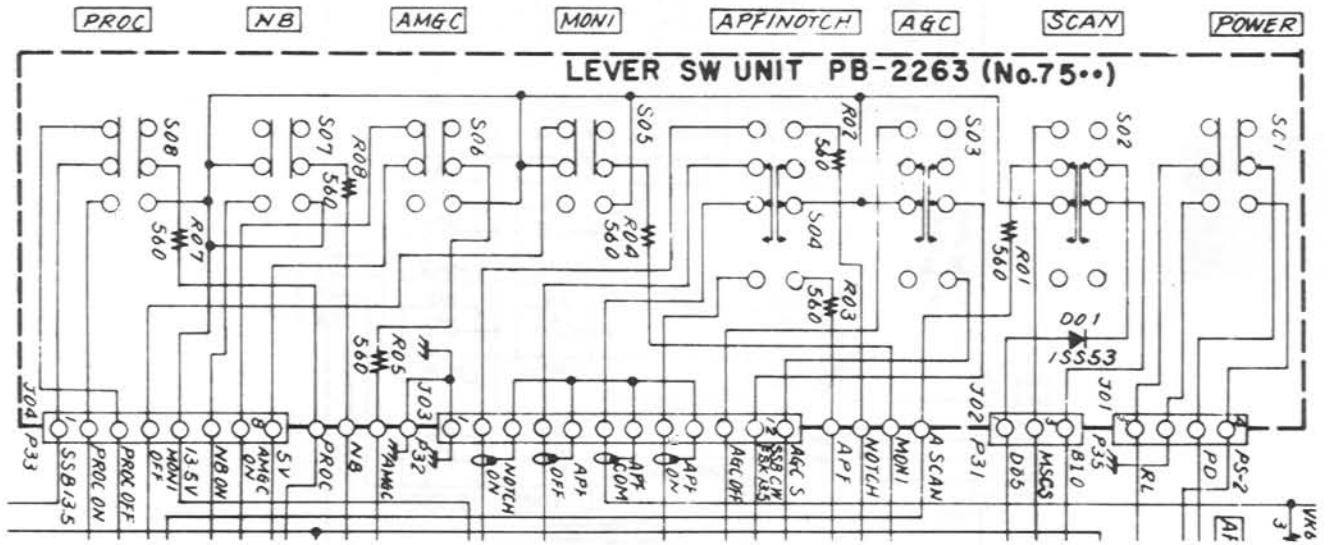

COMPONENT APPLICATIONS

- D7501 1SS53 Si Diode Switch

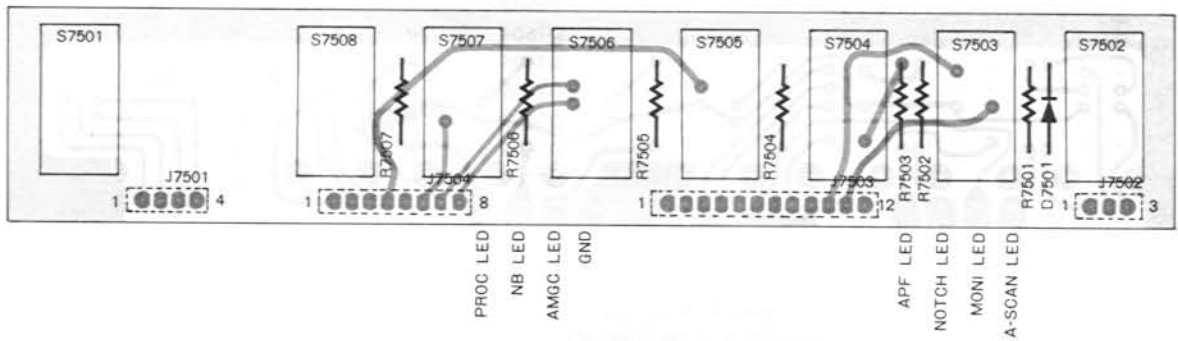

Viewed from component side

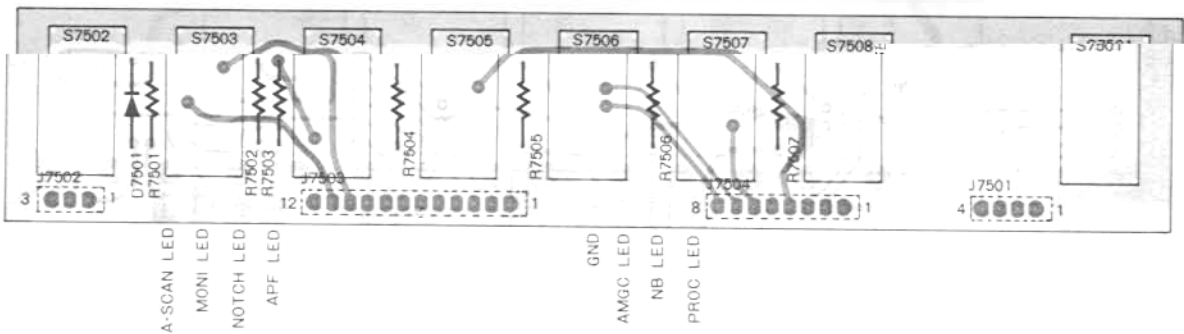

Viewed from solder side

KEYBOARD UNIT

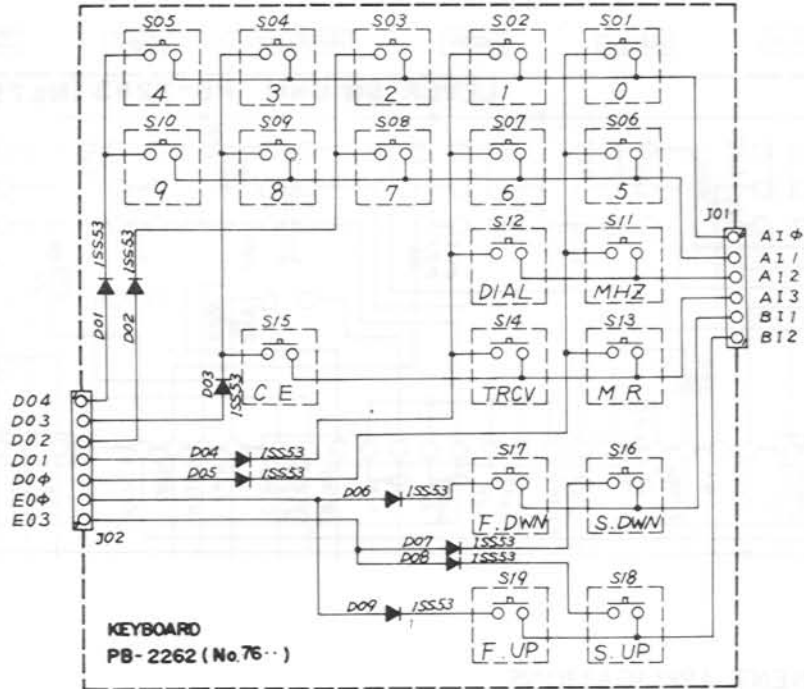

COMPONENT APPLICATIONS

D7601	1SS53	Si Diode	Switch
D7602	"	"	"
D7603	"	"	"
D7604	"	"	"
D7605	"	"	"
D7606	"	"	"
D7607	"	"	"
D7608	"	"	"
D7609	"	"	"

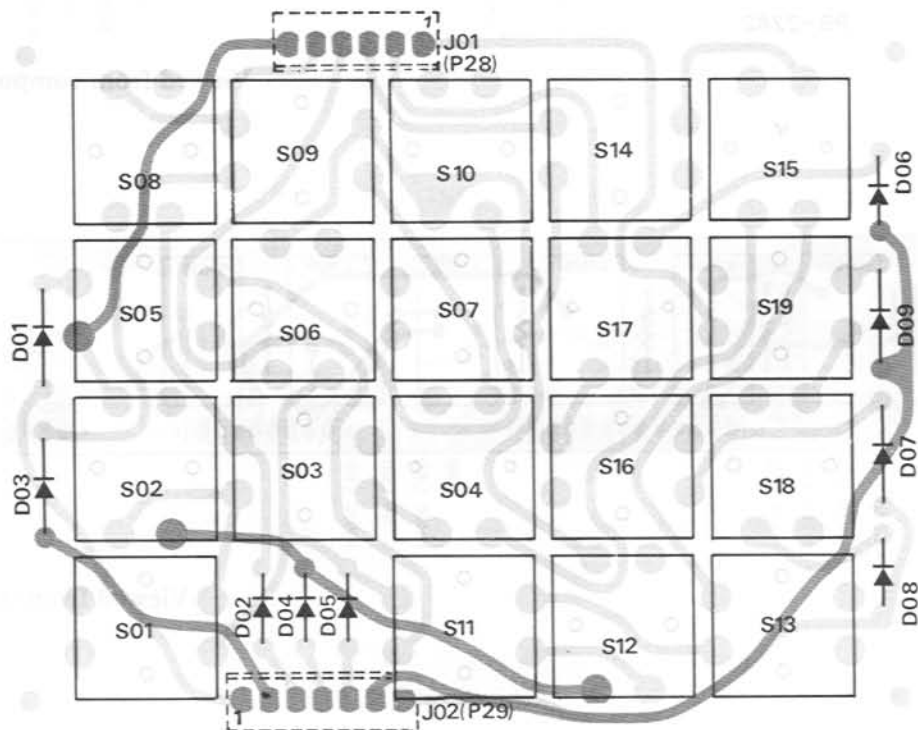

EXT CONTROL UNIT

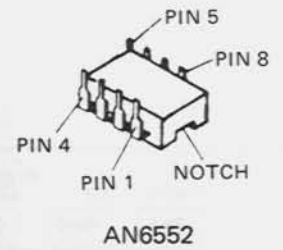
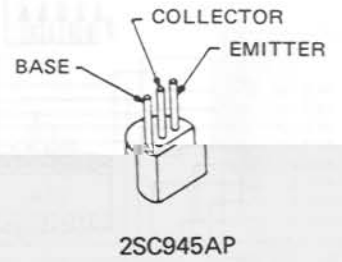
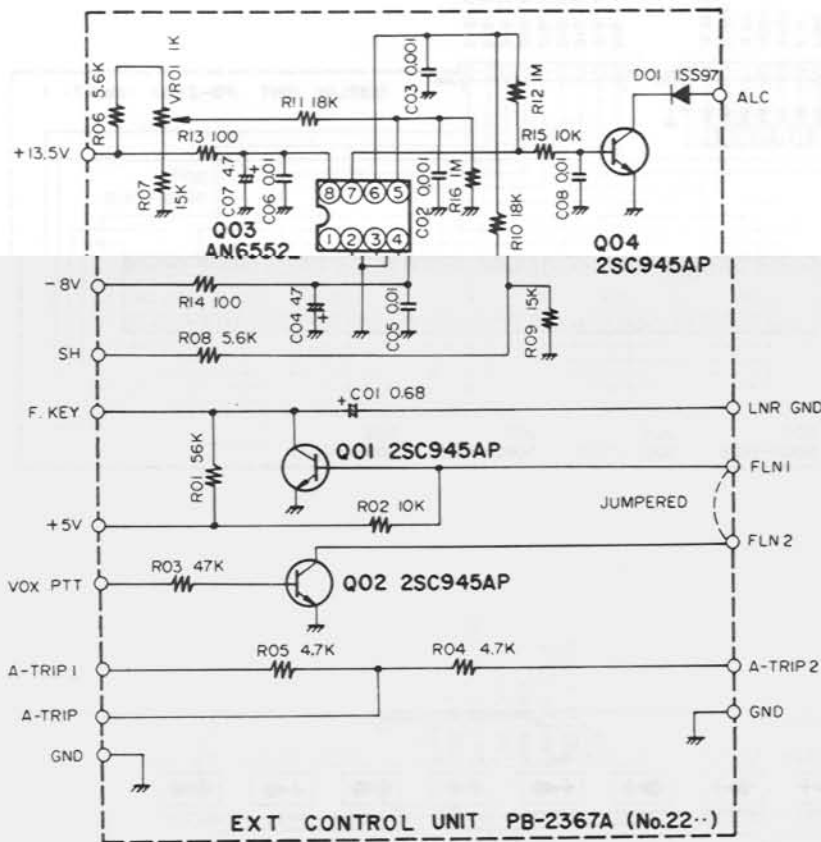

COMPONENT APPLICATIONS

Q2201	2SC945AP	Transistor	Switch
Q2202	"	"	"
Q2203	AN6552	IC	"
Q2204	2SC945AP	Transistor	"
D2201	1SS97	Schottky Barrier Di.	Switch

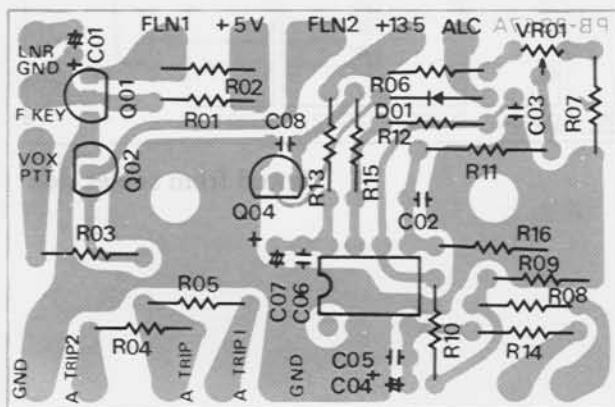

Viewed from component side

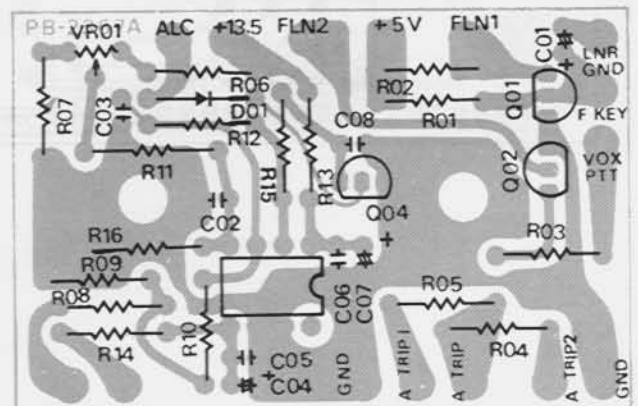

Viewed from solder side

DISPLAY UNIT

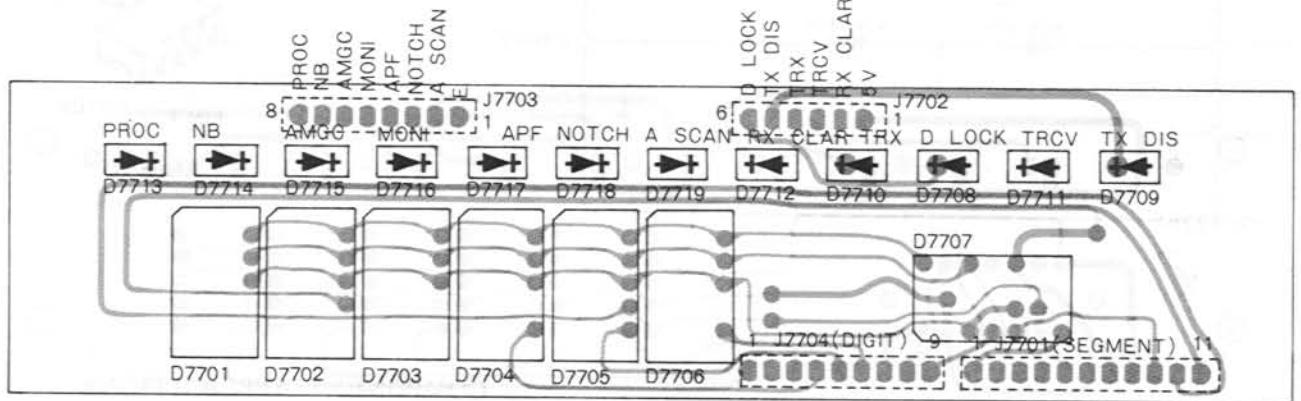
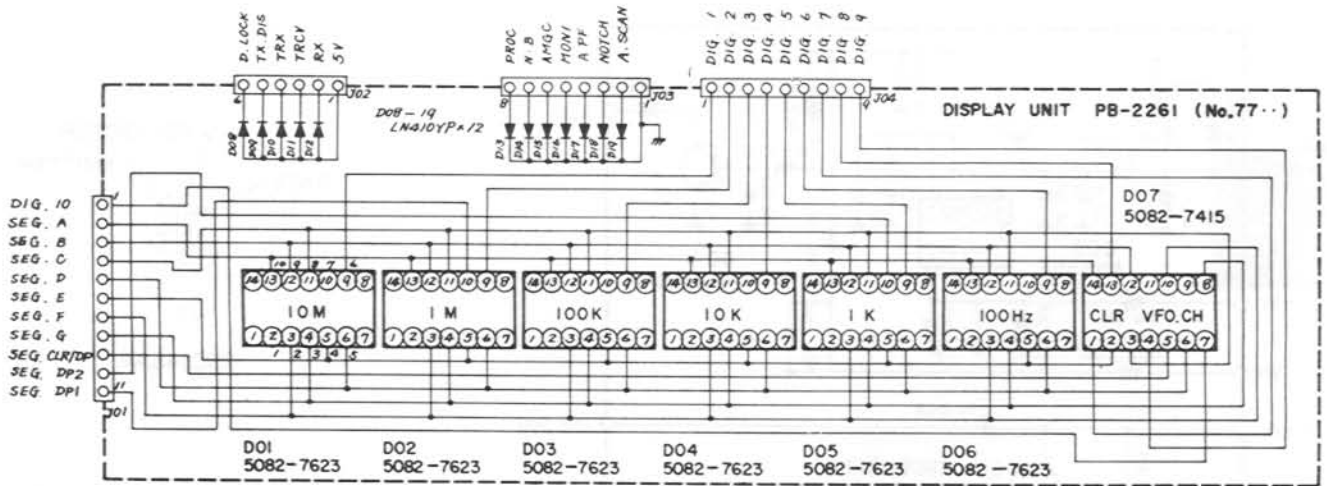

Viewed from component side

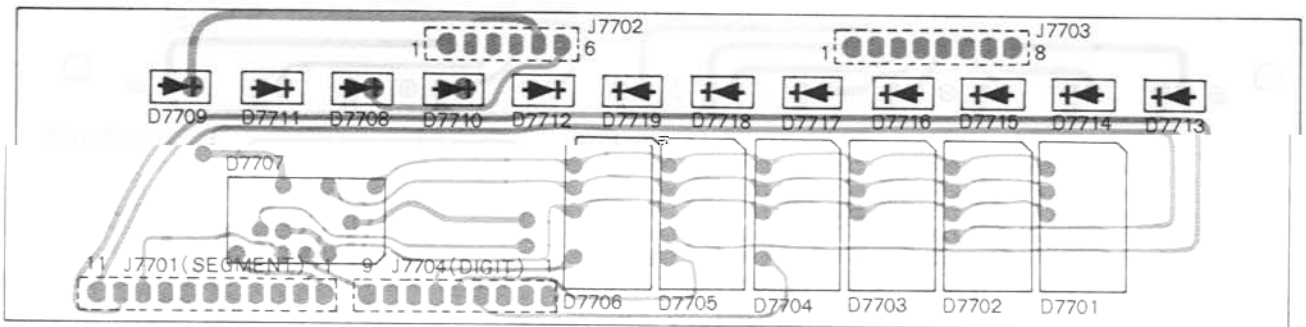

Viewed from solder side

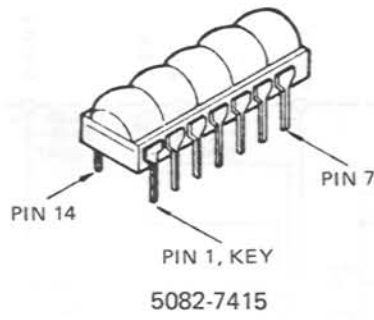
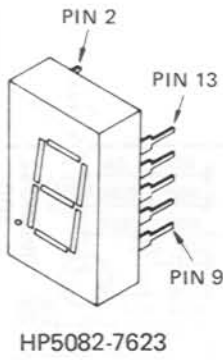

* D7701-7706 (HP5082-7623) is not used PIN 1, 7, 8, 14.

COMPONENT APPLICATIONS

D7701	HD5082-7623	Display LED	Frequency Display
D7702	"	"	"
D7703	"	"	"
D7704	"	"	"
D7705	"	"	"
D7706	"	"	"
D7707	HD5082-7415	"	Clarifier Frequency, VFO Channel Display
D7708	LN410YP	LED	Dial Lock Indicator
D7709	"	"	TX Disable Indicator
D7710	"	"	TRX Clarifier Indicator
D7711	"	"	Transceiver Indicator
D7712	"	"	RX Clarifier Indicator
D7713	"	"	Processor Indicator
D7714	"	"	NB Indicator
D7715	"	"	AMGC Indicator
D7716	"	"	Monitor Indicator
D7717	"	"	Audio Peak Filter Indicator
D7718	"	"	Notch Filter Indicator
D7719	"	"	Auto Scan Indicator

FM UNIT

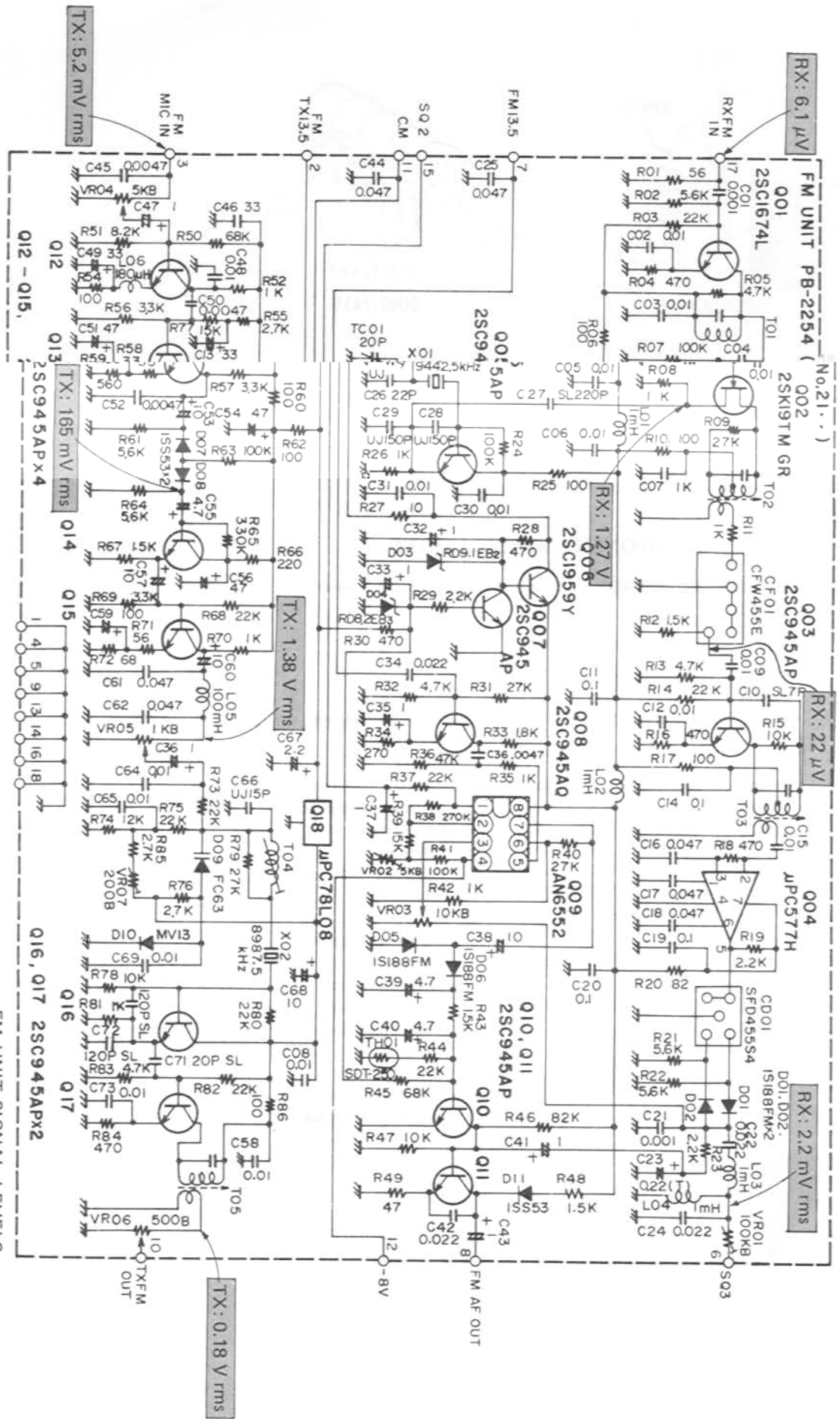

FM UNIT SIGNAL LEVELS

- TX: FREQUENCY; 29.0 MHz
- DEVIATION; 3.5 KHz @ 1 KHz Mod.
- MIC INPUT; 1 mV
- RX: FREQUENCY; 29.0 MHz
- ANT INPUT; 0.38 μV (ON 20 dB)

FM UNIT PARTS LAYOUT

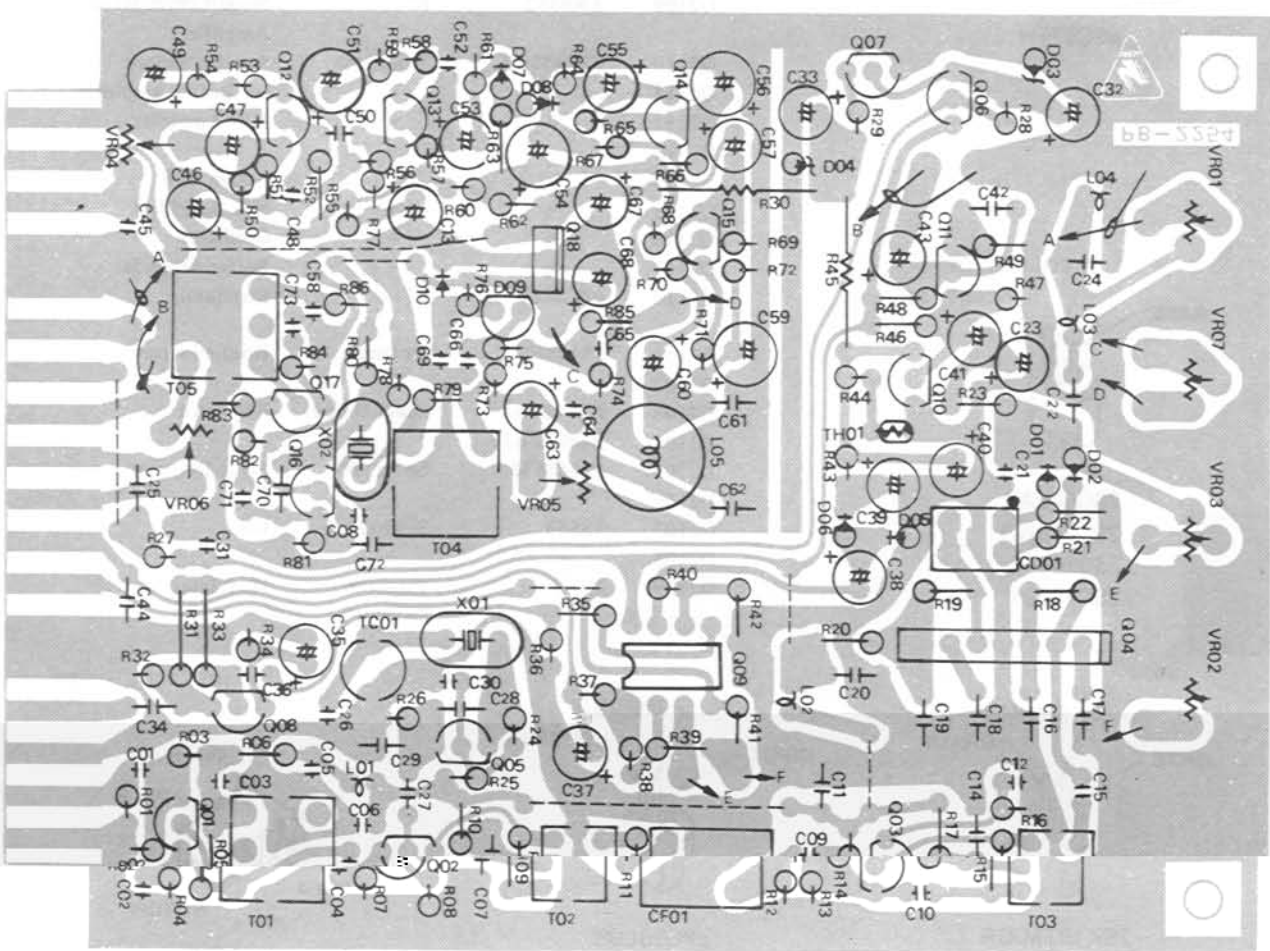
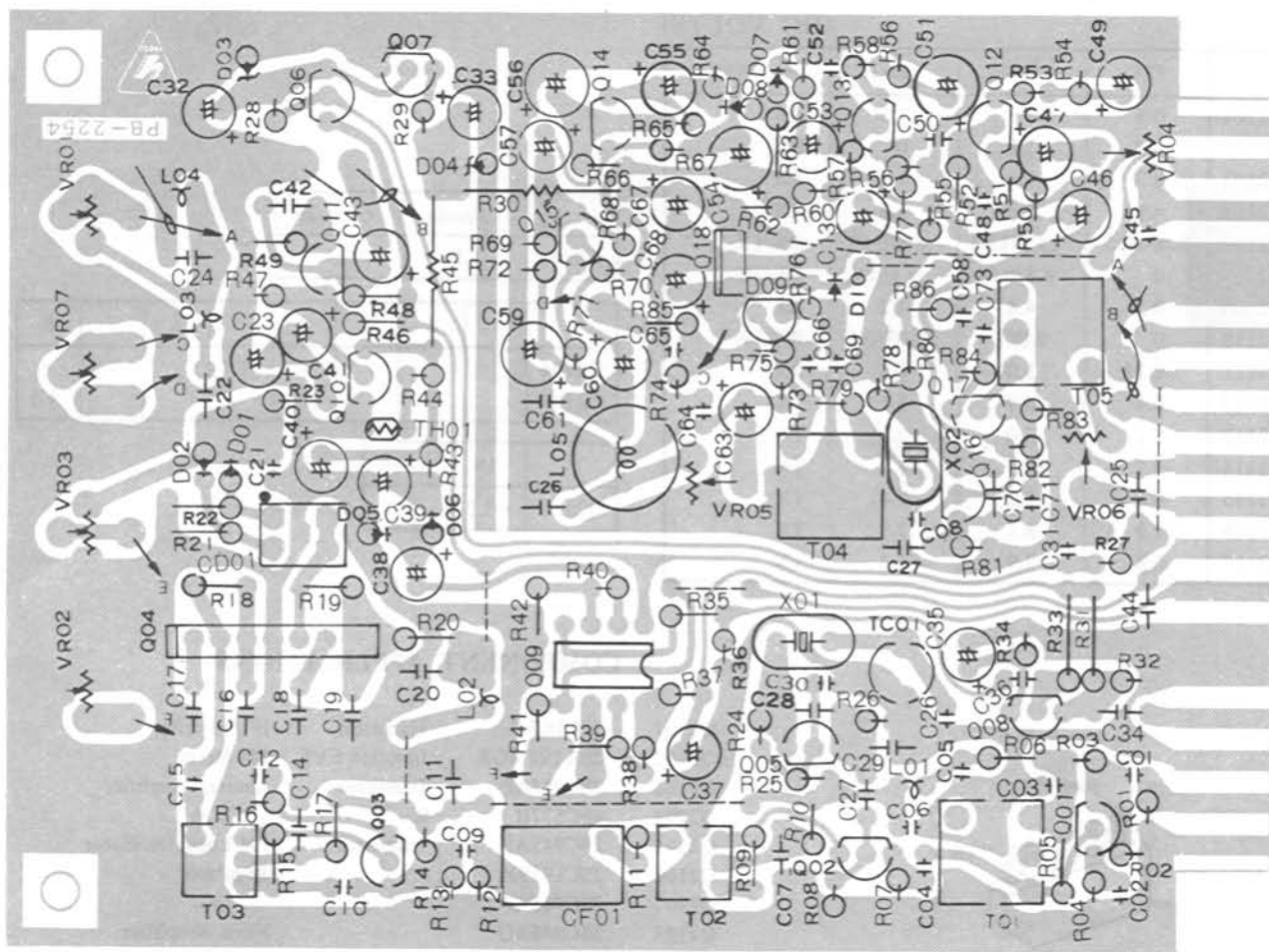

FM UNIT (OPTION)

VOLTAGE CHART

(DC VOLTS)

	E(S)	C(D)	B(G)	REMARKS
Q2101	0.8	7.8	1.5	RX
Q2102	2.2	7.8	0	RX
Q2103	0.7	7.8	1.4	RX
Q2105	4.9	7.5	4.3	RX
Q2106	8.0/-0.5	13.0/13.1	8.8/0.05	RX/TX
Q2107	0	8.8/0.05	0.1/0.8	RX/TX
Q2108	0.5	4.8	1.2	RX
Q2110	0	0.8/0	0.03/0.6	RX/TX
Q2111	0.13	3.0	0.8	RX
Q2112	0.4	6.9	1.1	TX
Q2113	1.1	5.0	1.7	TX
Q2114	5.7	10.7	6.2	TX
Q2115	0.8	5.2	1.4	TX
Q2116	1.9	8.1	2.5	TX
Q2117	0.8	7.9	1.4	TX

	Anode	Cathode
D2109	1.3	6.5

	1	2	3	4	5	6	7	8
Q2104				0	3.7		7.1	-
Q2109				-8.0				8.0

	IN	OUT
Q2118	13.2	8.0

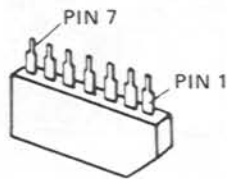

μPC577H

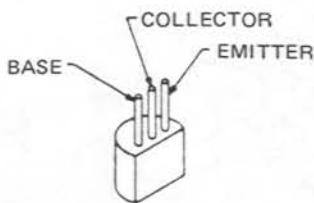

2SC945AP
2SC945AQ
2SC1674L
2SC1959Y

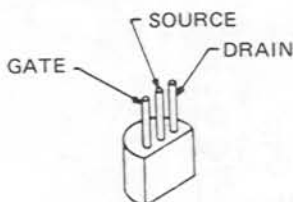

2SK19TM-GR

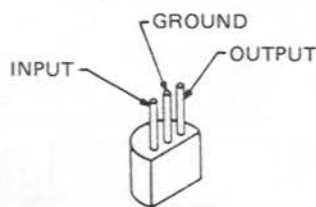

μPC78L08

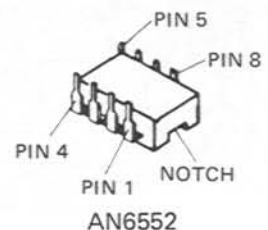

AN6552

COMPONENT APPLICATIONS

Q2101	2SC1674L	Transistor	IF Amplifier
Q2102	2SK19TMGR	Junction FET	FM Mixer
Q2103	2SC945AP	Transistor	Limiter Amplifier
Q2104	μPC577H	IC	"
Q2105	2SC945AP	Transistor	FM Local Oscillator
Q2106	2SC1959Y	"	Regulator
Q2107	2SC945AP	"	"
Q2108	2SC945AQ	"	Noise Amplifier
Q2109	AN6552	IC	Noise/Center Meter Amplifier
Q2110	2SC945AP	Transistor	Squelch Switch
Q2111	"	"	AF Buffer Amplifier
Q2112	"	"	MIC Amplifier
Q2113	"	"	"
Q2114	"	"	Active LPF
Q2115	"	"	MIC Amplifier
Q2116	"	"	Oscillator
Q2117	"	"	Buffer Amplifier
Q2118	μPC78L08	IC	Regulator
D2101	1S188FM	Ge Diode	Discriminator
D2102	"	"	"
D2103	RD9.1EB2	Zener Diode	Regulator
D2104	RD8.2EB3	"	"
D2105	1S188FM	Ge Diode	Noise Detector
D2106	"	"	"
D2107	1SS53	Si Diode	IDC
D2108	"	"	"
D2109	FC63	Varactor Diode	Modulator

MEMO

MEMO TO THE DIRECTOR OF THE BUREAU OF ELECTRICITY

FROM: [Illegible Name]

SUBJECT: [Illegible Subject]

[Illegible body text]

[Illegible body text]

REVISION OF PARTS ON CIRCUIT BOARD

[Illegible text]

[Illegible text]

SOLDERING AND DESOLDERING TECHNIQUE ON PRINTED CIRCUIT BOARDS

The FT-ONE circuit boards are tough, but mishandling during soldering can cause circuit traces to "lift." While this does not cause permanent damage to the board, much servicing trouble can result, because of the tendency for this lifted trace to break. A few simple precautions will keep your circuit boards in A-1 condition.

1. Use only a 12 to 30 watt chisel-tip soldering iron. Yes, some "repairmen" have been known to use small blowtorches on cards.
2. Use only a soldering iron equipped with a three-wire cord, with the tip grounded. Also acceptable is a soldering iron isolated through a transformer. An old soldering iron or gun may have 117 volts on the tip, and will certainly cause more damage than it repairs!
3. USE ONLY 60/40 ROSIN CORE SOLDER. Acid core solder should be thrown away if you find it in your radio shop!
4. Use a solder sucker and solder tape to ensure a professional repair job.
5. If you do lift a trace, don't worry! Read on to find out how to repair traces like a pro.

NOTES ON USE OF CMOS COMPONENTS:

As CMOS devices are extremely sensitive to damage from static electricity, special precautions must be observed.

In storage, use only sponge specially designed for CMOS components.

When installing a CMOS part in a socket, or on a circuit board, be certain that the power is off. In addition, the technician should rest his hand on the chassis as the component is inserted, so as to place his hand at the same potential as the chassis (better to discharge small amounts of static electricity through your fingers than through a \$5 IC!).

When soldering a CMOS part onto a circuit board, use a low wattage iron, and be sure to ground the tip with a clip lead, if the tip is not grounded through a three-wire power cord.

INSERTION OF PARTS ON CIRCUIT BOARDS

All of the below are acceptable ways of inserting components into circuit board mounting holes.

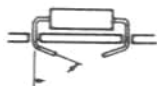

(a) Bend leads slightly



(b) Straight-in mounting



(c) Vertical mounting

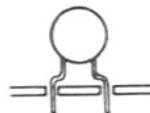

(d) Preformed disc ceramic capacitor



(e) Preformed resistor, diode, etc.

BASIC SOLDERING PRACTICE

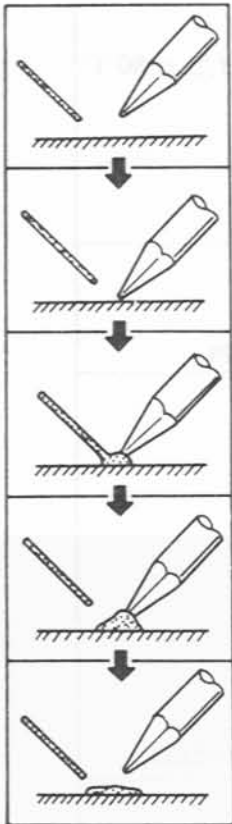

- (1) Prepare soldering iron and solder.
- (2) Apply soldering iron to surface to be soldered.
- (3) Apply solder to heated surface.
- (4) When enough solder is applied, remove iron. Continue to apply heat until solder flows cleanly.
- (5) Remove iron from work. Do not apply more heat than necessary for good solder flow.

Soldering to terminal posts:

(Be certain to apply heat to both post and wire.)

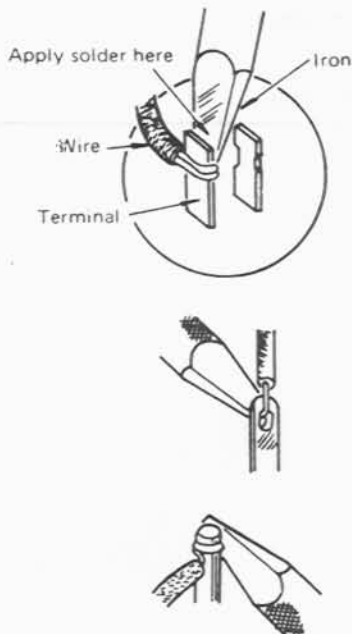

EXAMPLES OF POOR SOLDERING PRACTICE

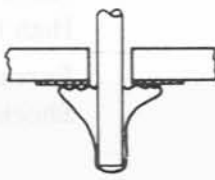
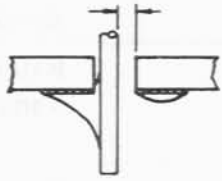
<p>Solder bridge (caused by use of too much solder)</p> 
<p>"Cold joint" (caused by insufficient heat to part of work, resulting in poor solder flow)</p> 
<p>Unstable joint (caused by insufficient heat or solder)</p> 

If you have previously lifted a trace, make an etch cut on each side of the lifted trace as shown in the drawing, and install a wire bridge.

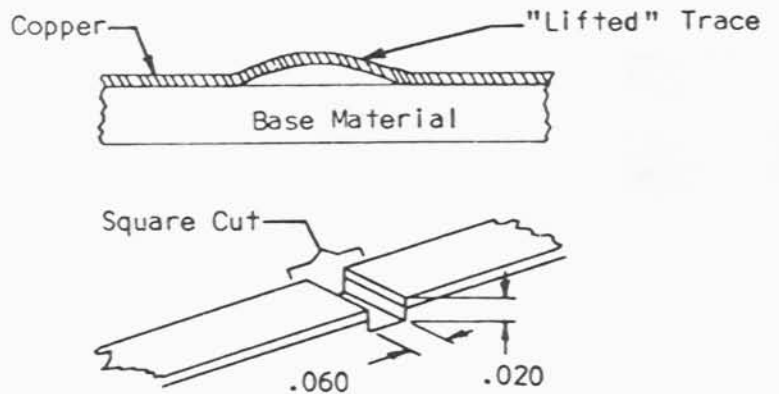

Coat Cut Area With Eastman 910

PARTS LIST

MAIN CHASSIS					SPEAKER
Symbol No.	Part No.	Description	SP1	M4090031	SE-77KYA 4Ω, 3W
		DIODE			
D2-7	G2090027	Si 1SS53			
D1	G2090003	" V06B			TRANSFORMER
			PT1	L3030092A	
			CH1	L2030001	T-12
		RESISTOR	L1	L0021255	Balun Trans
R3	J10276100	Carbon Composition 1/2W GK 10Ω	FH1,2	P2000012	FUSE HOLDER SN-2059
R2	J10276101	" " " " 100Ω			
R8	J01245681	" Film 1/4W TJ 680Ω			FUSE
R7	J01245102	" " " " 1kΩ	F1	Q0000002	1A (Backup)
R6	J01245823	" " " " 82kΩ	F2	Q0000007	10A (100-117 VAC)
R1	J32009011	Meter Shunt	F2	Q0000005	5A (200-234 VAC)
					LAMP
		POTENTIOMETER	PL1	Q1000047	13.5V 80mA
VR1	J62800061	K16B20034-2KBX2 2KBX2			
VR2	J62800062	K16BA004C-10KBX2 10KBX2			
VR3	J60800080	K1611008TE-10KB 10KB			CONNECTOR
VR4	J60800081	K1611008TE-10KC 10KC	J1	P1090246	D8-701B-00
VR5	J62800063	K16BA100C-5M1111 20KB,10KB 20KΩB,10KΩB	J2	P1090034	D7-701B-00
VR6	J62800064	K16BA004C-10KB,10KA 10KΩB,10KΩA	J3	P0090094	PA-125
VR7	J61800012	K162B00B8J-100KCX2 100KΩCX2	J4	P0090249	QS-AB8M(I)
VR8	J62800065	K16BA004C-5KBX2 5KB,5KB	J5	P1090004	SG-7814
VR9	J62800066	K16BA100C-5M1111- 500KC,1MB 500KΩC,1MΩB	J7	P1090001	SG-7701
			J8	P1090003	SG-7615
			J9	P0090158	FM-214-8SS
			J10(with wire)	T9204322A	3191-06R1
			J11	P1090194	MBR-06B
			J12	P1090111	7015J
			MJ1,13	P4090009	3305-014-011SN
		CAPACITOR	MJ2	P4090017	1150-044-009
C11,12	K13170102	Ceramic Disc 50WV 0.001μF (DB200YF102Z5L2)	MJ3-6,8-12	P4090016	1150-036-009
C2,3,8-10	K14180103	" " 63WV 0.01μF (RD871-IFZ103Z)	MJ7	P4090010	3305-018-011SN
C4,5	K12329001	" " 1.4KV 0.01μF (ECKDAL103PE)			TERMINAL BOARD
C21	K13170103	" " 50WV 0.01μF (DB201YF103Z5L5)	SQ1	Q9000133	(RCV-1, RCV-2, RF OUT)
C6,7,13-19	K13170473	" " 50WV 0.047μF (DB207YF473Z5L5)	SQ2	Q9000134	(SP, FSK, AF OUT...)
C20	K40179012	Electrolytic 50WV 4.7μF (50RE4R7)			PLUG
C1	K41140228	" 25WV 2200μF (25TL2200)	P1 (with wire)	T9204296	3191-02P1
		SWITCH	P2 (")	T9204297A	3191-04P1
S1	N6090001	SBN-22-09	P3 (")	T9301701	(TMP15DP)
S2	N0190096	SRN404CN	P4 (")	T9301702	TMP15DP
S4,5	N0190094	SRN202CN	P5,6 (")	T9204298	5251-02
S3	N0190091	SRN1025N	P9 (")	T9204301	5251-02
S6	N0190093	SRN2046N	P10 (")	T9204302	5251-02
			P11 (")	T9204303	5251-02
			P12 (")	T9204304	5251-02
			P13 (")	T9204305	5251-03
			P31 (")	T9204316	5251-03
			P14,18(")	T9204306A	5251-04
			P34 (")	T9204319	5251-04
		METER	P35 (")	T9204320	5251-04
M1	M0290027	AP-90	P15,17(")	T9204307A	5251-05
M2	M0290028	AP-90	P16 (")	T9204308A	5251-06
			P23,27(")	T9204311B	5251-06
			P28 (")	T9204313	5251-06
		RELAY	P7 (")	T9204299	5251-07
RL1	M1190033	LY3F DC12V	P29 (")	T9204314	5251-07
			P8,20 (")	T9204300A	5251-08

REPAIR PARTS

P24 (with wire)	T9204312	5251-08	Q1015	G4800730G	3SK73GR
P30 (")	T9204315	5251-08			
P33 (")	T9204318	5251-08			
P19 (")	T9204308A	5251-09			DIODE
P22,26(")	T9204310A	5251-09	D1045	G2090015	Zener RD6.2EB3
P21,25(")	T9204309A	5251-11	D1041	G2090047	" RD8.2EB3

R1102	J02245224	Carbon Film 1/4W SJ 220kΩ	C1048	K10176102	Ceramic Disc 50WV B 1000pF (DD104B102K50V02)	
			C1060	K10176152	" " " " 1500pF (DD105B152K50V02)	
		THERMISTOR				
TH1001	G9090002	D22A	C1017,1036	K10176222	" " " " 2200pF (DD106B222K50V02)	
		POTENTIOMETER				
VR1001-1009	J50749202	H0812A003-2KB 2KΩB	C1013,1162,1164, 1168,1178-1181, 1186,1187,1189, 1191,1193, 1197-1199,1202, 1203,1206-1211, 1214-1217	K13170102	" " " " 0.001μF (DB200YF102Z5L2)	
		CAPACITOR				
C1196	K00173060	Ceramic Disc 50WV SL 6pF (DD104SL060J50V02)	C1002,1004,1010, 1015,1026,1028, 1030,1041,1044, 1053,1056,1065, 1068,1074,1077, 1083,1086,1092, 1095,1099,1103, 1107,1109,1111, 1112-1130,1132, 1135,1137,1138, 1140,1143, 1146-1148,1151, 1155,1158,1160, 1161,1163, 1165-1167, 1170-1175, 1182-1184,1195, 1200,1201,1212	K14180103	" " 63WV 0.01μF (RD871-1FZ103Z)	
C1153	K00175150	" " " " 15pF (DD104SL150J50V02)				
C1104,1106	K00175180	" " " " 18pF (DD104SL180J50V02)				
	K00175220	" " " " 22pF (DD104SL220J50V02)				
C1096,1098	K00179006	" " " " 24pF (DD104SL240J50V02)				
C1176,1177	K00175270	" " " " 27pF (DD104SL270J50V02)				
	K00175330	" " " " 33pF (DD104SL330J50V02)				
C1070,1072,1078, 1082	K00175390	" " " " 39pF (DD104SL390J50V02)	C1101,1169,1185, 1188,1190,1192, 1194	K13170473	" " 50WV 0.047μF (DB207YF473Z5L5)	
C1079,1081,1152, 1154	K00175470	" " " " 47pF (DD104SL470J50V02)				
C1218,1219	K00179011	" " " " 62pF (DD104SL620J50V02)	C1133,1134	K19149025	Semiconductor Ceramic 25WV 0.1μF (UAT13X104K-L46AE)	
C1069,1073,1088, 1090	K00175680	" " " " 68pF (DD104SL680J50V02)	C1001,1005,1009, 1131,1136,1139, 1141,1142,1156, 1157	K40179013	Electrolytic 50WV 1μF (50RE1)	
C1087,1091	K00175820	" " " " 82pF (DD104SL820J50V02)				
C1105	K00179013	" " " " 91pF (DD105SL910J50V02)	C1081,1012,1027, 1042,1054,1066, 1075,1084,1093, 1100,1108,1110, 1144,1145,1149, 1205	K40129004	" " 16WV 10μF (16RE10)	
C1062,1064	K00175101	" " " " 100pF (DD105SL101J50V02)				
C1097	K00179017	" " " " 130pF (DD105-257SL131J50V02)	C1003,1014,1029, 1043,1055,1067, 1076,1085,1094, 1102,1213	K40129016	" " 22μF (16RE22)	
C1050,1052	K00175151	" " " " 150pF (DD104SL151J50V02)				
C1038,1040,1057, 1071	K00175181	" " " " 180pF (DD104SL181J50V02)				
C1023,1025,1059, 1080	K00175221	" " " " 220pF (DD104SL221J50V02)	C1150,1159	K40129008	" " 33μF (16RE33)	
C1006,1008,1018, 1032,1035,1045, 1047,1061,1063, 1204	K00175271	" " " " 270pF (DD104SL271J50V02)				
					INDUCTOR	
C1016,1021,1037, 1051,1089	K00175331	" " " " 330pF (DD104SL331J50V02)	L1053	L1020700	0.45μH	
C1020,1033,1039	K00175391	" " " " 390pF (DD104SL391J50V02)	L1082-1084	L1190092	FL4H-R47M 0.47μH	
C1049	K00175471	" " " " 470pF (DD104SL471J50V02)	L1048	L1190004	FL4H-R68M 0.68μH	
C1034,1046	K10176561	" " " " B 560pF (DD104B561K50V02)	L1046,1050,1059	L1190005	FL4H-1R0M 1μH	
C1019,1022,1024, 1031	K10176681	" " " " 680pF (DD104B681K50V02)	L1033	L1190006	FL4H-1R2M 1.2μH	
C1007,1058	K10176821	" " " " 820pF (DD104B821K50V02)	L1051,1055	L1020701	1.4μH	
				L1190087	FL4H-1R5M 1.5μH	
				L1031,1035,1038	L1190007	FL4H-1R8M 1.8μH
				L1052,1054	L1020702	2.0μH
				L1043	L1190008	FL4H-2R2M 2.2μH
				L1047,1049	L1190126	FL4H-2R4M 2.4μH
					L1190009	FL4H-3R3M 3.3μH
					L1190010	FL4H-3R9K 3.9μH
				L1032,1034,1036, 1040	L1190011	FL4H-4R7K 4.7μH

L1025-1027,1041,1045	L1190111 L1190013	FL4H-5R6K FL4H-6R8K	5.6μH 6.8μH	Q3028,3029 Q3005,3007,3009,3011,3020,3026,3027,3031,3036,3038	G3307320B G3309451P	2SC732TMBL 2SC945AP
L1028,1029,1037,1039	L1190070	FL4H-8R2K	8.2μH			
L1042,1044	L1190014	FL4H-100K	10μH	Q3001	G3309451Q	2SC945AQ
L1019-1023	L1190015	FL5H-120J	12μH			
L1016,1017	L1190019	FL5H-150K	15μH			FET
L1015	L1190021	FL5H-180K	18μH	Q3034	G3090023	JF1033B
L1006,1009,1010	L1190023	FL5H-220K	22μH	Q3033,3035	G3090035	2SK191M-GR
L1002,1003,1007,1014	L1190073	FL5H-270K	27μH	Q3002-3004,3023-3025	G4800730G	3SK73GR
L1013	L1190027	FL5H-390K	39μH			
L1008,1057	L1190029	FL5H-470K	47μH			
L1058,1060,1062,1071,1075,1078,1080,1081	L1190020	FL5H-151K	150μH			DIODE
				D3007,3010,3023	G2090165	Varactor FC52M-5
				D3017	G2090043	" MV-104
L1001,1004,1005,1011,1012,1018,1024,1030,1056,1063-1066,1072,1074,1079	L1190017	FL5H-102K	1mH	D3001,3002,3004,3005,3013,3015	G2090029	Ge 1N60
				D3016	G2090152	Zener RD5.1E-B-2
				D3014,3018	G2090155	" RD9.1E-B-2
L1073	L0021120			D3003,3006,3008,3009,3011,3012,3019,3020	G2090027	Si 1SS53
L1089	L1020691A					
L1067-1070,1076,1077,1086	L1020693A			D3021,3022	G2090118	Schottky 1SS97
L1087	L1020694A					
L1088	L1020692A					CRYSTAL
L1085	L1020696A			X3001	H0102275	HC-18/U 9.4425MHz
				X3002	H0102469	HC-18/U3P 15.511MHz
				X3003	H0102429	HC-18/U3P 24.5MHz
				X3004	H0102471	HC-18/U3P 15.514MHz
		TRANSFORMER				
T1001,1003,1004,1006,1007	L0020883					THERMISTOR
T1002,1009	L0020856			TH3001,3002	G9090001	SDT-250
T1005	L0021123					
T1008,1010	L0021122A					
						RESISTOR
				R3010	J02245829	Carbon Film 1/4W SJ 8.2Ω
				R3144	J02245220	" " " " 22Ω
J1001	P0090218	5045-02A		R3096-3098,3109	J02245470	" " " " 47Ω
				R3006,3039,3040,3065,3129,3148	J02245560	" " " " 56Ω
	Q5000011	Wrapping terminal C		R3004,3028,3043,3044,3063,3080,3084,3092,3093,3103,3114,3130,3134,3143	J02245101	" " " " 100Ω
				R3108	J02245121	" " " " 120Ω
				R3128	J02245151	" " " " 150Ω
				R3012,3019,3025,3059,3145	J02245221	" " " " 220Ω
				R3023	J02245271	" " " " 270Ω
				R3110	J02245331	" " " " 330Ω
				R3011	J02245391	" " " " 390Ω
				R3015,3017,3045,3064,3085,3142	J02245471	" " " " 470Ω
		IC		R3135	J02245561	" " " " 560Ω
Q3022	G1090246	AN6552		R3003,3060	J02245681	" " " " 680Ω
Q3030	G1090153	MB8718M		R3016,3022,3027,3035,3048,3074,3081,3086,3112,3126,3131	J02245102	" " " " 1kΩ
Q3010	G1090257	MC14066BCP		R3116	J02245122	" " " " 1.2kΩ
Q3008,3032	G1090012	SN16913P		R3037,3049,3055,3155	J02245152	" " " " 1.5kΩ
Q3037	G1090080	μPC78L08				
		TRANSISTOR		R3070,3113	J02245222	" " " " 2.2kΩ
Q3006,3039	G3107331P	2SA733AP		R3117	J02245272	" " " " 2.7kΩ
Q3021	G3107331Q	2SA733AQ				

R3005,3038,3100	J02245332	Carbon Film 1/4W SJ 3.3kΩ	C3094	K00175180	Ceramic Disc 50WV SL 18pF (DD104SL180J50V02)
R3067	J02245392	" " " " 3.9kΩ	C3093	K00179005	" " " " 20pF (DD104SL200J50V02)
R3009,3013,3020, 3033,3104,3115, 3118-3125, 3150,3152	J02245472	" " " " 4.7kΩ	C3148	K00175390	" " " " 39pF (DD104SL390J50V02)
R3046,3052,3053, 3056	J02245562	" " " " 5.6kΩ	C3058,3142	K06175470	" " " " UJ 47pF (DD104UJ470J50V02)
R3029,3057	J02245682	" " " " 6.8kΩ	C3001,3136,3063	K00175470	" " " " SL 47pF (DD104SL470J50V02)
R3002,3075	J02245822	" " " " 8.2kΩ	C3140	K06179047	" " " " UJ 51pF (DD104UJ510J50V02)
R3030,3047,3058, 3066,3069,3071, 3076,3079,3087, 3094,3095,3147	J02245103	" " " " 10kΩ	C3074,3121,3123	K00173560	" " " " SL 56pF (DD104SL560J50V02)
R3007,3014,3021, 3087	J02245153	" " " " 15kΩ	C3056,3057	K06175680	" " " " UJ 68pF (DD105-257UJ680J50V02)
R3008,3041,3061, 3077,3082,3107	J02245183	" " " " 18kΩ		K02175101	" " " " CH100pF (DD107CH101J50V02)
R3042,3057,3062, 3073,3078,3083, 3099,3105,3106, 3133,3140,3154	J02245223	" " " " 22kΩ	C3065,3095,3122, 3133,3135,3149, 3150	K00175101	" " " " SL 100pF (DD105SL101J50V02)
R3024,3141	J02245333	" " " " 33kΩ	C3059,3071,3072	K06175101	" " " " UJ 100pF (DD106UJ101J50V02)
R3001,3034,3050, 3051,3136,3149, 3151,3153	J02245473	" " " " 47kΩ	C3076,3077	K10176101	" " " " B 100pF (DD104B101K50V02)
R3068,3072,3132, 3146	J02245563	" " " " 56kΩ	C3130,3131	K00175121	" " " " SL 120pF (DD105SL121J50V02)
R3031	J02245683	" " " " 68kΩ		K02175151	" " " " CH150pF (DD109CH151J50V02)
R3018, 3137-3139	J02245104	" " " " 100kΩ	C3066,3067	K10176151	" " " " B 150pF (DD104B151K50V02)
R3032,3111,3127	J02245124	" " " " 120kΩ	C3002,3003	K00175151	" " " " SL 150pF (DD104SL151J50V02)
R3090,3091	J02245184	" " " " 180kΩ	C3021,3046,3047, 3134	K00175221	" " " " 220pF (DD107SL221J50V02)
R3088,3089	J02245224	" " " " 220kΩ	C3013	K00175331	" " " " 330pF (DD107SL331J50V02)
R3026	J02245274	" " " " 270kΩ			
	J02245394	" " " " 390kΩ			
R3036	J02245105	" " " " 1MΩ			
		BLOCK RESISTOR			
RB3001	J40900026	RK1/16B6R220K 220kΩx6	C3006,3007,3024, 3026,3036, 3086-3088,3090, 3096,3097,3099, 3128,3132, 3137-3139,3147, 3158	K13170102	" " " " 0.001μF (DB200YF102Z5L2)
RB3002	J40900006	RK1/16B8R47KΩ 47kΩx8			
		POTENTIOMETER			
VR3001	J50749102	H0812A002-1KB 1kΩB	C3004,3005,3014, 3018,3025,3030, 3031,3033, 3037-3045, 3048-3055,3060, 3062-3064, 3068-3070, 3073,3075,3078, 3079,3081,3083, 3091,3100,3102, 3105,3108-3115, 3117,3118,3120, 3124-3127,3129, 3144,3152-3154, 3157,3159,3161, 3162	K14180103	" " " " 63WV 0.01μF (RD871-1FZ-103Z63Z)
VR3002	J50749202	" 005-2KB 2kΩB			
VR3007	J50749502	" 004-5KB 5kΩB			
VR3004,3005	J50749202	" 003-2KB 2kΩB			
VR3006	J50749104	" 008-100KB 100kΩB			
		CAPACITOR			
C3092	K00179001	Ceramic Disc 50WV SL 0.5pF (DD104SL0R5C50V02)			
C3056	K06172030	" " " " UJ 3pF (DD104UJ030J50V02)			
C3089	K00172040	" " " " 4pF (DD104SL040C50V02)			
C3055,3057	K06172050	" " " " 5pF (DD104UJ050J50V02)			
C3098	K00173070	" " " " SL 7pF (DD104SL070D50V02)	C3008-3012, 3015-3017,3019, 3020,3022,3023, 3027,3028,3035	K13170473	" " " " 50WV 0.047μF (DB207YF473Z5L5)
C3061	K02173080	" " " " CH 8pF (DD104CH080D50V02)	C3032,3101,3103, 3151	K40179013	Electrolytic " 1μF (50RE1)
C3145,3160	K00173100	" " " " SL 10pF (DD104SL100D50V02)	C3106,3107	K40179001	" " " " 1μF (ECE-A1HK01050V1)
C3141	K02175150	" " " " CH 15pF (DD104CH150J50V02)	C3029,3034, 3080,3082,3084, 3085,3104,3116, 3119,3146,3155, 3156	K40129004	" " " " 16WV 10μF (16RE10)
C3143	K06175150	" " " " UJ 15pF (DD104UJ150J50V02)			

REPAIR PART

TC3001,3002	R9100024	TRIMMER CAPACITOR ECV1ZW60x40 60pF		Q4027,4029,4030, 4032,4034,4035 4037	G3309451P	2SC945AP	
				Q4019	G3307320G	2SC732TMGR	
		INDUCTOR					
L3012,3025-3027	L1190092	FL4H-R47M	0.47μH				
L3010,3024	L1190004	FL4H-R68M	0.68μH			DIODE	
L3007	L1190006	FL4H-1R2K	1.2μH	D4006	G2090029	Ge	1N60
L3033,3034	L0021268		2.4μH	D4001-4005, 4007-4017,4019, 4022-4026	G2090027	Si	1SS53
L3021,3022	L1190027	FL5H-390K	39μH				
L3002	L1190033	FL5H-820K	82μH				
L3030-3032	L1190018	FL5H-121K	120μH	D4021	G2090158	Zener	RD4.7EB2
L3001,3003,3006, 3008,3009,3011, 3013-3017,3020, 3023,3028	L1190020	FL5H-151K	150μH	D4018	G2090152	"	RD5.1EB2
				D4020	G2090042	"	RD8.2EB3
				D4027	G2090012	"	WZ110
L3004,3005,3029	L1190017	FL5H-102K	1mH			CRYSTAL FILTER	
L3018,3019	L1190035	FL7H-392J	3.9mH	XF4001	H1102035	XF-8.9KP	
						RESISTOR	
		TRANSFORMER		R4113	J10276229	Carbon Composition	
T3001	L0020158					1/2W GK 2.2Ω	
T3002,3003	L0020101			R4122	J02245220	"	Film 1/4W SJ 22Ω
T3004	L0021118A			R4001,4007,4165, 4166	J02245560	"	" " " " 56Ω
	L0021119A						
	L0021121			R4013,4043,4062, 4103,4114,4132, 4136,4140,4145, 4147,4149,4155	J02245101	"	" " " " 100Ω
T3007	L0021124A						
T3008	L0021125A						
T3009	L0021127A						
T3010,3011	L0021126A			R4089	J01245221	"	" " " " TJ 220Ω
T3012	L0021092A			R4112,4164	J02245221	"	" " " " SJ 220Ω
T3013	L0020404			R4066,4162	J02245271	"	" " " " 270Ω
				R4005,4168	J02245331	"	" " " " 330Ω
				R4097,4121,4144, 4163	J02245471	"	" " " " 470Ω
J3001	P0090256	5046-08A		R4060	J02245561	"	" " " " 560Ω
				R4148	J02245681	"	" " " " 680Ω
				R4082,4117,4128, 4152,4159	J02245821	"	" " " " 820Ω
	Q5000011	Wrapping terminal C		R4057,4074,4084, 4102,4124,4126, 4127,4129,4131, 4139,4141,4146, 4151,4154,4156	J02245102	"	" " " " 1kΩ
AF UNIT							
Symbol No.	Part No.	Description					
PB-2252	F0002252A	Printed Circuit Board		R4092	J02245122	"	" " " " 1.2kΩ
PB-2252A	C0022520	P.C.B. with Components		R4012,4172	J02245152	"	" " " " 1.5kΩ
				R4157	J02245182	"	" " " " 1.8kΩ
				R4036-4039,4138	J02245222	"	" " " " 2.2kΩ
		IC		R4002	J02245272	"	" " " " 2.7kΩ
Q4006,4020	G1090246	AN6552		R4047,4053,4064, 4116	J02245332	"	" " " " 3.3kΩ
Q4036	G1090063	TA7060AP					
Q4002	G1090257	MC14066BCP		R4096,4171	J02245392	"	" " " " 3.9kΩ
Q4013	G1090053	MC14081BCP		R4003,4021,4034, 4035,4041,4044, 4050,4061,4071, 4073,4093,4094, 4107,4108,4111	J02245472	"	" " " " 4.7kΩ
Q4008	G1090384	MC14538BCP					
Q4031,4033	G1090340	MC1496CP					
Q4003,4004	G1090077	MC3403P					
Q4001	G1090012	SN16913P		R4067,4080,4087, 4133	J02245562	"	" " " " 5.6kΩ
Q4005	G1090084	μPC78L05					
Q4024,4025	G1090080	μPC78L08		R4070,4109,4115	J02245682	"	" " " " 6.8kΩ
Q4028	G1090164	μPC2002H		R4158	J02245822	"	" " " " 8.2kΩ
				R4006,4008,4011, 4016,4025, 4045,4046,4052, 4058,4063,4068, 4069,4075,4077, 4083,4099,4105, 4110,4120	J02245103	"	" " " " 10kΩ
		TRANSISTOR					
Q4007,4009-4012, 4014-4018,4021, 4022,4023,4026	G3309451P	2SC945AP					

R4130,3137,4153,4170	J02245103	Carbon Film	1/4W SJ	10k Ω	C4058-4060	K50177223	Mylar	50WV	0.022 μ F
							(50F2U223M)		
R4169	J02245123	" "	" "	12k Ω	C4019,4020,4050,4051	K50177333	"	"	0.033 μ F
R4026,4029	J02245153	" "	" "	15k Ω			(50F2U333M)		
R4017,4085	J02245183	" "	" "	18k Ω	C4100,4101	K50177473	"	"	0.047 μ F
R4072,4078,4104,4106	J02245223	" "	" "	22k Ω			(50F2U473M)		
R4095,4118,4135,4142,4161	J02245273	" "	" "	27k Ω	C4071,4076	K50177104	"	"	0.1 μ F
							(50F2U104M)		
R4019,4020,4098,4119,4123,4125,4134,4143,4160	J02245333	" "	" "	33k Ω	C4127	K40179010	Electrolytic	"	0.47 μ F
							(50RE-R47)		
R4018,4086	J02245393	" "	" "	39k Ω	C4031,4035,4129	K40179013	"	"	1 μ F
R4014,4048,4049,4054,4056,4079,4081,4150	J02245473	" "	" "	47k Ω			(50RE1)		
					C4013,4016,4017	K40179009	"	"	2.2 μ F
R4055,4059	J02245683	" "	" "	68k Ω			(50RE2R2)		
R4022-4024,4030-4032,4065,4090,4091,4100	J02245104	" "	" "	100k Ω	C4023,4027,4028	K40179011	"	"	3.3 μ F
							(50RE3R3)		
R4101	J02245124	" "	" "	120k Ω	C4045,4070	K40179012	"	"	4.7 μ F
R4015,4033,4076,4088	J02245224	" "	" "	220k Ω			(50RE4R7)		
R4027,4028,4042,4051	J02245684	" "	" "	680k Ω	C4003,4004,4006,4011,4024,4029,4030,4033,4038,4039,4041,4043,4048,4052-4055,4057,4061,4064,4066,4067,4074,4079,4085-4087,4096,4098,4099,4102-4104,4107,4109,4118,4122,4125,4128	K40129004	"	16WV	10 μ F
R4004,4009,4010	J02245105	" "	" "	1M Ω			(16RE10)		
		THERMISTOR							
TH4001,4002	G9090011	SDT-1000			C4018,4049,4056,4088,4097,4111,4126	K40129002	"	"	47 μ F
							(16RE47)		
		POTENTIOMETER							
VR4009,4011	J50749501	H0812A001-500B		500 Ω B	C4073	K40129007	"	"	100 μ F
VR4010	J50749102	" 002-1KB		1k Ω B			(16RE100)		
VR4004,4008	J50749502	" 004-5KB		5k Ω B	C4009	K40129009	"	"	220 μ F
VR4001,4003,4005,4006	J50703103	EVL-V0AA00B14		10k Ω B			(16RE220)		
	J50749503	H0812A	50k Ω B	50k Ω B	C4072,4075	K40129019	"	"	1000 μ F
VR4002	J50749105	H0812A	1M Ω B	1M Ω B			(16RC1000)		
		CAPACITOR			C4130	K70167684	Tantalum	35WV	0.68 μ F
C4090	K00179005	Ceramic disc	50WV SL	20pF			(CS15E1VR68M)		
		(DD104SL200J50V02)			C4032,4036	K70127225	"	16WV	2.2 μ F
C4046,4047	K10176471	" " " B		470pF			(CS15E1C2R2M)		
		(DD104B471K50V02)					"	16WV	6.8 μ F
							(CS15E1C6R8M)		
C4001,4002,4005,4007,4008,4010,4012,4014,4034,4037,4040,4065,4068,4077,4078,4080-4084,4091-4095,4105,4106,4108,4110,4112,4114-4116,4119,4120,4123,4124,4131	K14180103	" " " "	63WV	0.01 μ F	L4003,4014,4015	L1190023	FL5H-220K		22 μ H
		(RD871-1FZ-103Z63V)			L4018	L1190018	FL5H-121K		120 μ H
					L4001,4002,4004-4007,4009,4010,4013,4016,4017	L1190020	FL5H-151K		150 μ H
					L4008,4012	L1190017	FL5H-102K		1mH
					L4011	L1190102	S-104K		100mH
C4015,4069,4089,4113,4117,4121,4135	K13170473	" " " "	50WV	0.047 μ F					
		(DB207YF473Z5L5)							
C4132-4134	K13170103	" " " "	"	0.001 μ F					
		(DB201YF103Z5L5)			T4001,4002	L0021084A			
C4022	K50177102	Mylar	"	0.001 μ F					
		(50F2U102M)							
C4021	K50177222	" " " "	"	0.0022 μ F					
		(50F2U222M)			J4001	P1090248	IL-D-9S-S3TA2		
C4062,4063	K50177472	" " " "	"	0.0047 μ F					
		(50F2U472M)							
C4025,4026	K50177682	" " " "	"	0.0068 μ F					
		(50F2U682M)				Q5000011	Wrapping terminal C		

REPAIR PARTS

CONTROL UNIT				R5050	J10246100	Carbon Composition		
Symbol No.	Part No.	Description				1/4W GK 10Ω		
PB-2251	F0002251	Printed Circuit Board		R5152-5161	J02245680	"	Film	" SJ 68Ω
	C0022510	P.C.B. with Components		R5045,5049	J02245101	"	"	" " 100Ω
				R5106-5110	J02245121	"	"	" " 120Ω
				R5051	J02245221	"	"	" " 220Ω
		IC		R5047,5059	J02245331	"	"	" " 330Ω
Q5048,5060	G1090027	MC14001BCP		R5070	J02245391	"	"	" " 390Ω
Q5025,5026	G1090068	MC14011BCP		R5061,5162-5167	J02245102	"	"	" " 1kΩ
Q5050	G1090176	MC14012BCP		R5001,5004,5007, 5010,5013,5016, 5019,5022,5025, 5028,5031-5033	J02245222	"	"	" " 2.2kΩ
Q5052	G1090067	MC14013BCP						
Q5034,5059	G1090257	MC14066BCP						
Q5047,5051	G1090126	MC14069UBCP						
Q5031,5045,5046	G1090053	MC14081BCP		R5116,5118,5120, 5122,5124,5126, 5128,5130,5132, 5134,5137,5139, 5141,5143,5145, 5147,5149,5151	J02245272	"	"	" " 2.7kΩ
Q5049	G1090149	MC14510BCP						
Q5042-5044	G1090364	MN1201A						
Q5053	G1090367	MN9005						
Q5024	G1090365	SN7406N						
Q5021	G1090378	TBP18SA030N-0378 (BPF SELECT)		R5086	J02245332	"	"	" " 3.3kΩ
				R5101-5106	J02245392	"	"	" " 3.9kΩ
Q5022	G1090379	TBP18SA030N-0379 (TX BAND SELECT)		R5055	J02245472	"	"	" " 4.7kΩ
				R5058	J02245562	"	"	" " 5.6kΩ
Q5023	G1090380	TBP18SA030N-0380 (VCO SELECT)		R5136,5138,5140, 5142,5144,5146, 5148,5150	J02245822	"	"	" " 8.2kΩ
		TRANSISTOR		R5002,5003,5005, 5006,5008,5009, 5011,5012,5014, 5015,5017,5018, 5020,5021,5023, 5024,5026,5027, 5029,5030, 5034-5039, 5111-5113	J02245103	"	"	" " 10kΩ
Q5072-5079	G3107190R	2SA719R						
Q5002,5004,5006, 5008,5010,5012, 5014,5016,5018, 5020,5035-5040	G3107331Q	2SA733AQ						
Q5032,5033, 5054-5058,5061	G3309451P	2SC945AP		R5088-5092,5117, 5119,5121,5123, 5125,5127,5129, 5131,5133,5135	J02245123	"	"	" " 12kΩ
Q5001,5003,5005, 5007,5009,5011, 5013,5015,5017, 5019,5027,5028, 5030,5041, 5062-5071	G3313170R	2SC1317R		R5056	J02245153	"	"	" " 15kΩ
				R5087	J02245183	"	"	" " 18kΩ
				R5060,5083, 5093-5100	J02245333	"	"	" " 33kΩ
Q5029	G3402880K	2SD288K						
				R5065	J10246333	"	Composition	1/4W GK 33kΩ
		DIODE		R5040,5041,5053, 5057,5064,5066, 5071,5073,5115	J02245473	"	Film	" SJ 47kΩ
D5025	G2090029	Ge	1N60					
D5001-5007, 5012-5014, 5016-5019, 5021-5024, 5026-5030, 5032-5053, 5056,5057	G2090027	Si	1SS53	R5082	J02245563	"	"	" " 56kΩ
				R5075-5078	J02245823	"	"	" " 82kΩ
				R5043,5062,5072, 5074,5081,5084, 5085,5114	J02245104	"	"	" " 100kΩ
D5058	G2090201	Zener	RD3.3EB3	R5068,5079	J02245224	"	"	" " 220kΩ
D5008-5011,5031, 5055	G2090193	"	RD5.6EB3	R5054	J02245274	"	"	" " 270kΩ
				R5080	J02245474	"	"	" " 470kΩ
D5015	G2090181	"	HZ7B1L	R5042	J02245564	"	"	" " 560kΩ
D5020	G2090155	"	RD9.1EB2	R5052	J02245105	"	"	" " 1MΩ
		IC SOCKET						
QS5001	P3090033	116-16-30-114	16P					BLOCK RESISTOR
QS5002	P3090036	116-40-30-114	40P	RB5002-5004	J40900025	RK1/16B8R2.2K	1/16W	2.2kΩx8
				RB5001	J40900024	RK1/16B5R10K	"	10kΩx5
				RB5005	J40900011	RK1/16B6R10K	"	10kΩx6
		RES						
R5044	J02245569	Carb.	Film	1/4W SJ	5.6Ω			
R5046,5048,5069, 5168	J02245100	"	"	"	10Ω			

REPAIR PARTS

		CRYSTAL				
X6003	H0102431	HC-18/U	20.0MHz	R6028,6029,6031, 6093,6106,6121, 6122,6132,6138, 6139,6141,6152, 6165,6173,6180, 6184,6185,6187, 6209,6210	J02245103	Carbon Film 1/4W SJ 10kΩ
X6001	H0102432	"	48.615MHz			
X6002	H0102433	"	54.28MHz			
		RESISTOR				
R6055	J10276339	Carbon Composition 1/2W 3.3Ω		R6201	J02245153	" " " " 15kΩ
R6073	J02245479	" Film	1/4W SJ 4.7Ω	R6079	J02245183	" " " " 18kΩ
R6036,6039,6091, 6110,6112,6117, 6153,6197	J02245100	" " " "	10Ω	R6002,6004,6008, 6010,6015,6020, 6025,6030,6094, 6107,6133,6142, 6151,6163,6164, 6172,6179,6188	J02245223	" " " " 22kΩ
R6034	J02245180	" " " "	18Ω	R6052,6100,6120, 6169	J02245333	" " " " 33kΩ
R6087,6115,6158	J02245220	" " " "	22Ω	R6178	J02245393	" " " " 39kΩ
R6042,6045	J02245390	" " " "	39Ω	R6037,6049,6051, 6099,6101,6206	J02245473	" " " " 47kΩ
R6127	J10246680	" Composition "	GK 68Ω	R6068,6086	J02245563	" " " " 56kΩ
R6069,6198	J02245680	" Film "	SJ 68Ω	R6076,6168	J02245683	" " " " 68kΩ
R6082	J02245820	" " " "	82Ω	R6114,6177	J02245823	" " " " 82kΩ
R6006,6012,6017, 6022,6027,6032, 6040,6041,6043, 6063-6065,6071, 6075,6077,6081, 6095,6096,6103, 6109,6129,6130, 6134,6137,6143, 6145,6146,6148, 6150,6167,6171, 6174,6176,6182, 6189,6191,6204, 6212,6213	J02245101	" " " "	100Ω	R6050,6098,6104, 6105,6157,6161, 6162,6181	J02245104	" " " " 100kΩ
R6056	J02245151	" " " "	150Ω	R6092,6192,6195	J02245124	" " " " 120kΩ
R6054,6066,6067	J02245181	" " " "	180Ω	R6128	J10246124	" Composition 1/4W GK 120kΩ
R6044,6053,6074, 6102	J02245221	" " " "	220Ω	R6207	J02245334	" Film " SJ 330kΩ
R6033,6035	J02245271	" " " "	270Ω	R6215	J02245394	" " " " 390kΩ
R6090,6135,6199	J02245331	" " " "	330Ω	R6126	J02245565	" " " " 5.6MΩ
R6070,6205,6214	J02245391	" " " "	390Ω			BLOCK RESISTOR
R6048,6072,6078, 6097,6131,6144, 6149,6154	J02245471	" " " "	470Ω	RB6001	J40900025	RK1/16B8R2.2K 1/16W 2.2kΩx8
R6190	J10246471	" Composition	1/4W GK 470Ω	RB6002	J40900019	RK1/16B8R100K 1/16W 100kΩx8
R6175	J02245561	" Film "	SJ 560Ω			POTENTIOMETER
R6085,6155	J02245681	" " " "	680Ω	VR6002	J51740501	EVNB3AA00B52 500ΩB
R6170	J02245821	" " " "	820Ω	VR6001	J51752503	RGS6-FAN 50KB 50kΩB
R6038,6047,6057, 6061,6088,6108, 6111,6113,6116, 6123,6124,6136, 6140,6166,6183, 6186,6196,6208	J02245102	" " " "	1kΩ			CAPACITOR
R6089	J10246102	" Composition	1/4W GK 1kΩ	C6183	K00172010	Ceramic Disc 50WV SL 1pF (DD104SL010C50V02)
R6125,6193,6194	J02245152	" Film "	SJ 1.5kΩ	C6115	K00172020	" " " " 2pF (DD104SL020J50V02)
R6046,6058-6060, 6062,6118,6119, 6156,6200,6211	J02245222	" " " "	2.2kΩ	C6062,6064,6122	K06172030	" " " " UJ 3pF (DD104UJ030J50V02)
R6159	J10246222	" Composition	1/4W GK 2.2kΩ	C6089,6172,6268, 6269	K00172030	" " " " SL 3pF (DD104SL030C50V02)
R6147	J02245392	" Film "	SJ 3.9kΩ	C6214	K06172040	" " " " UJ 4pF (DD104UJ040J50V02)
R6202,6216	J02245472	" " " "	4.7kΩ	C6219	K00172050	" " " " SL 5pF (DD104SL050C50V02)
R6160	J02245562	" " " "	5.6kΩ	C6063,6121,6124	K06172050	" " " " UJ 5pF (DD104UJ050J50V02)
R6083,6084	J02245682	" " " "	6.8kΩ	C6112	K00173060	" " " " SL 6pF (DD104SL060D50V02)
R6080,6203	J02245822	" " " "	8.2kΩ	C6087	K00173090	" " " " " 9pF (DD104SL090D50V02)
R6001,6003,6005, 6007,6009,6011, 6013,6014,6016, 6018,6019,6021, 6023,6024,6026	J02245103	" " " "	10kΩ	C6185	K02173090	" " " " CH 9pF (DD104CH090D50V02)
				C6005,6012,6019, 6026,6034,6042 6171,6216,6218	K06173100	" " " " UJ 10pF (DD104UJ100J50V02)
				C6181,6203	K02173100	" " " " CH 10pF (DD104CH100D50V02)

C7008	K40179013	Electrolytic (50RE1)	50WV	1 μ F			RESISTOR
					R7104	J10276560	Carbon Composition
C7002,7005,7007, 7009,7010,7015, 7017,7019,7029, 7031,7032,7034, 7036	K40129004	" (16RE10)	16WV	10 μ F			1/2W TJ 56 Ω
					R7107,7122	J02245101	" Film 1/4W SJ 100 Ω
					R7121	J02245221	" " " " 220 Ω
					R7114	J02245471	" " " " 470 Ω
C7022,7024,7025	K40129016	" (16RE22)	"	22 μ F	R7102,7118	J02245561	" " " " 560 Ω
					R7109	J01245561	" " " " TJ 560 Ω
C7004,7006	K40129002	" (16RE47)	"	47 μ F	R7101	J02245681	" " " " SJ 680 Ω
					R7106	J02245821	" " " " 820 Ω
C7026	K40149008	" (25RE10)	25WV	10 μ F	R7120,7124	J02245102	" " " " 1k Ω
					R7125	J01245102	" " " " TJ 1k Ω
C7027	K40149003	" (25RE100)	"	100 μ F	R7110	J02245152	" " " " SJ 1.5k Ω
					R7127	J01245152	" " " " TJ 1.5k Ω
C7001	K40149017	" (25RC1000)	"	1000 μ F	R7123	J02245182	" " " " SJ 1.8k Ω
					R7128	J01245222	" " " " TJ 2.2k Ω
C7038	K70167474	Tantalum (CS15E1VR47M)	35WV	0.47 μ F	R7112	J02245222	" " " " SJ 2.2k Ω
					R7119,7126	J02245272	" " " " 2.7k Ω
C7041	K70167105	" (CS15E1V010M)	"	1 μ F	R7103,7108,7129	J02245472	" " " " 4.7k Ω
					R7115,7116	J02245103	" " " " 10k Ω
					R7105	J02245123	" " " " 12k Ω
					R7111,7130	J02245223	" " " " 22k Ω
		INDUCTOR			R7113	J02245104	" " " " 100k Ω
L7001	L2030068				R7117	J02245155	" " " " 1.5M Ω
L7002	L1190036	FL11H-683J	68mH				POTENTIOMETER
					VR7103	J50749102	H0812A002-1KB 1k Ω B
					VR7101,7102	J50749202	H0812A003-2KB 2k Ω B
		TRANSFORMER			VR7105	J50710103	V10K8-1-2 10KB 10KB
PT7001	L3030094				VR7104	J50710105	V10K8-1-2 1MB 1M Ω B
		RELAY					CAPACITOR
RL7001	M1190015	G2V-2			C7106	K00175120	Ceramic Disc 50WV SL 12pF (DD104SL120J50V02)
RL7002	M1190032	G2E			C7124	K00179006	" " " " 24pF (DD104SL240J50V02)
		CONNECTOR			C7110	K00179011	" " " " 62pF (DD104SL620J50V02)
J7001	P0090186	EMCS0352M			C7109	K00179013	" " " " 91pF (DD105SSL910J50V02)
P7001	P1090249	EMCM0201			C7101	K00175471	" " " " 470pF (DD109SL471J50V02)
					C7111,7112,7114, 7120,7121	K13170102	" " " " 0.001 μ F (DB200YF102Z5L2)
					C7104,7105,7115, 7117,7122	K14180103	" " " " 63WV 0.01 μ F (RD871-1FZ-103Z63V)
					C7102,7103,7107, 7108	K13170473	" " " " 50WV 0.047 μ F (DB207YF473Z5L5)
		TRANSISTOR			C7113,7116,7118, 7123	K40129004	Electrolytic 16WV 10 μ F (16RE10)
Q7101,7102,7105	G3107331P	2SA733AP			C7119	K70167474	Tantalum 35WV 0.47 μ F (CS15E1VR47)
Q7103	G3309451P	2SC945AP					
		FET					TRIMMER CAPACITOR
Q7104	G3090035	2SK19TM-GR			TC7101	K91000019	ECV-1ZW10x40 10pF
		DIODE					INDUCTOR
D7105-7108	G2090027	Si	1SS53				
D7101-7104	G2090118	Schottky	1SS97	L7101	L0020301A		
D7109	G2090015	Zener	RD6.2EB3	L7102	L1190020	FL5H-151K	150 μ H
							TRANSFORMER
					T7101	L0021159A	

REPAIR PARTS

RELAY			C7249	K30275161	Dipped mica 500WV 160pF (LCQ17161J5)
RL7101	M1190015	G2V-2 DC12V	C7204,7242,7252	K30275201	" " 200pF (LCQ17201J5)
CONNECTOR			C7218,7230,7245	K30275241	" " 240pF (LCQ17241J5)
J7101	P0090186	EMCS0352M	C7254	K30275271	" " 270pF (LCQ17271J5)
PJ7101-7103	P1090255	TMP-JA	C7223,7237,7247	K30275301	" " 300pF (LCQ17301J5)
PLUG			C7235	K30275331	" " 330pF (LCQ17331J5)
P7101	P1090249	EMCM0201	C7222	K30275361	" " 360pF (LCQ17361J5)
LAMP			C7202,7211,7215, 7238	K30275391	" " 390pF (LCQ18391J5)
PL7101	Q1000034	BF311-04080A 14V 0.2A	C7208	K30275431	" " 430pF (LCQ17431J5)
FUSE HOLDER			C7231,7240	K30275471	" " 470pF (LCQ18471J5)
FH7101	P2000003	F-3265	C7216	K30275511	" " 510pF (LCQ18511J5)
LPF UNIT			C7228,7233	K30275561	" " 560pF (LCQ18561J5)
Symbol No.	Part No.	Description	C7201,7221	K30275681	" " 680pF (LCQ18681J5)
PB-2259A	F0002259A	Printed Circuit Board	C7207,7209,7214, 7224	K30275911	" " 910pF (LCQ21911J5)
	C0022590	P.C.B. with Components	C7217,7226	K30279093	" " 1000pF (DM19D102J5)
DIODE			C7219	K30279095	" " 1200pF (DM19D122J5)
D7201-7218	G2090027	Si 1SS53	C7210	K30279125	" " 1300pF (DM19D132J5)
CAPACITOR			C7203,7212	K30279124	" " 1500pF (DM19D152J5)
C7257	K30275120	Dipped mica 500WV 12pF (LCQ12120J5)	C7205	K30279103	" " 1600pF (DM19D162J5)
C7262	K30275180	" " 18pF (LCQ11180J5)		K30279127	" " 2400pF (DM19D242J5)
C7248,7255	K30275200	" " 20pF (LCQ12200J5)	C7264-7283	K13170473	Ceramic Disc 50WV 0.047μF (DB207YF473Z5L5)
	K30275240	" " 24pF (LCQ12240J5)	INDUCTOR		
C7234,7241	K30275390	" " 39pF (LCQ12390J5)	L7225	L0021115	0.15μH
C7243,7263	K30275470	" " 47pF (LCQ12470J5)	L7226	L0021116	0.17μH
C7227	K30275510	" " 51pF (LCQ12510J5)	L7222,7227	L0021114	0.25μH
C7246,7253	K30275560	" " 56pF (LCQ12560J5)	L7219,7223,7224	L0021112	0.44μH
C7206	K30275680	" " 68pF (LCQ12680J5)	L7216	L0021110	0.5μH
C7220	K30275820	" " 82pF (LCQ12820J5)	L7220,7221	L0021113	0.68μH
C7236,7258-7260	K30275910	" " 91pF (LCQ12910J5)	L7213,7217	L0021109	0.85μH
C7261	K30275101	" " 100pF (LCQ12101J5)	L7218	L0021111	0.95μH
C7232	K30275111	" " 110pF (LCQ17111J5)	L7210,7214,7215	L0021107	1.3μH
C7239,7244	K30275121	" " 120pF (LCQ17121J5)	L7207	L0021105	1.5μH
C7213,7251	K30275131	" " 130pF (LCQ12131J5)	L7204	L0021102	1.7μH
C7225,7256	K30275151	" " 150pF (LCQ17151J5)	L7211,7212	L0021108	1.9μH
			L7208,7209	L0021106	2.3μH
			L7205	L0021103	2.8μH
			L7206	L0021104	3.1μH
			L7201	L0021100	3.3μH
			L7202,7203	L0021101	4.6μH
			RELAY		
			RL7201-7218	M1190032	G2E

		PLUG				DIODE	
P7201	P0090075	P7015		D7501	G2090027	Si	1SS53
P7202	T9301703	TMP15DP					
				R7501-7507	J01245561	RESISTOR Carbon Film 1/4W TJ 560Ω	
VFO UNIT				SWITCH			
Symbol No.	Part No.	Description					
PB-2265	F0002265	Printed Circuit Board		S7501,7505-7508	N3090004	SLE62251	
	C0022650	P.C.B. with Components		S7503,7504	N3090002	SLE62301	
				S7502	N3090007	SLE72301	
		TRANSISTOR				CONNECTOR	
Q7303,7304	G3309451P	2SC945AP		J7502	P0090219	5045-03A	
				J7501	P0090220	5045-04A	
				J7504	P0090224	5045-08A	
		PHOTO INTERRUPTER		J7503	P0090228	5045-12A	
Q7301,7302	G0090001	ON-1105					
		RESISTOR					
R7301,7302	J02245221	Carbon Film 1/4W SJ 220Ω					
R7303,7304	J02245682	" " " " 6.8kΩ					
R7305,7306	J02245103	" " " " 10kΩ		KEYBOARD UNIT			
				Symbol No.	Part No.	Description	
				PB-2262	F0002262	Printed Circuit Board	
					C0022620	P.C.B. with Components	
		CAPACITOR					
C7301	K40129004	Electrolytic 16WV 10μF (16RE10)					
				D7601-7609	G2090027	Si	1SS53
		CONNECTOR					
J7301	P0090252	5046-04A					
				S7601-7619	N4090049	SWITCH KHC10901	
				J7601	P0090222	5045-06A	
				J7602	P0090223	5045-07A	
PUSH SW UNIT							
Symbol No.	Part No.	Description					
PB-2264	F0002264	Printed Circuit Board					
	C0022640	P.C.B. with Components					
		DIODE		DISPLAY UNIT			
D7401-7404	G2090027	Si	1SS53	Symbol No.	Part No.	Description	
				PB-2261	F0002261	Printed Circuit Board	
					C0022610	P.C.B. with Components	
		SWITCH					
S7401(a-e)	N4090050	SUH52H					
				D7708-7719	G2090202	LED LN410YP	
		CONNECTOR					
J7401	P0090247	5046-08A					
				D7707	G2090110	LED DISPLAY 5082-7415	
				D7701-7706	G2090069	5082-7623	
LEVER SW UNIT				CONNECTOR			
Symbol No.	Part No.	Description					
PB-2263	F0002263	Printed Circuit Board		J7702	P0090222	5045-06A	
	C0022630	P.C.B. with Components		J7703	P0090224	5045-08A	
				J7704	P0090225	5045-09A	

		RADIAL FAN							
	R3056970								
									RESISTOR
				R9003,9005,9006,9009	J02245220	Carbon Film	1/4W SJ	22Ω	
			PLUG						
P8001(with wire)	T9204321	3191-06P1		R9167	J02245330	" "	" "	33Ω	
P8002	P0090075	P-7015		R9161,9193	J02245560	" "	" "	56Ω	
J8001	P1090111	J-7015		R9013,9027,9029,9041,9056,9065,9067,9077,9078,9098,9102,9106,9112,9115,9118,9120,9159,9171,9174,9175,9179,9188,9200	J02245101	" "	" "	100Ω	
IF UNIT									
Symbol No.	Part No.	Description							
PB-2255B	F0002255B	Printed Circuit Board							
	C0022550	P.C.B. with Components							
				R9033-9036,9070,9075,9080	J01245101	" "	" "	TJ 100Ω	
			IC						
Q9025	G1090077	MC3403P		R9206	J02245121	" "	" "	SJ 120Ω	
Q9030	G1090063	TA7060AP		R9048,9049,9124,9185,9207	J02245151	" "	" "	150Ω	
	G1090077	μA3403P		R9072,9073	J01245151	" "	" "	TJ 150Ω	
				R9044,9045	J02245181	" "	" "	SJ 180Ω	
			TRANSISTOR						
Q9026,9027	G3107331Q	2SA733AQ		R9060,9089,9092,9104,9169	J02245221	" "	" "	220Ω	
Q9005-9007,9013,9018-9024,9028,9031,9033	G3309451P	2SC945AP		R9204,9205	J02245271	" "	" "	270Ω	
				R9007,9008	J02245391	" "	" "	390Ω	
Q9012,9014	G33192300	2SC1923-O		R9014,9025,9031,9066,9101,9105	J02245471	" "	" "	470Ω	
				R9016,9053,9055,9058,9099,9103,9109,9110,9119	J02245561	" "	" "	560Ω	
			FET						
Q9010,9011	G3090034	2SK19TM-Y		R9046,9050,9088,9186,9197	J02245681	" "	" "	680Ω	
Q9004	G3800610G	2SK61GR		R9074	J01245821	" "	" "	TJ 820Ω	
Q9001-9003,9008,9009,9015-9017,9029,9032,9034-9036	G4800730G	3SK73GR		R9096,9097,9198	J02245821	" "	" "	SJ 820Ω	
				R9040,9061,9079,9091,9114,9122,9154,9162,9180,9182,9191,9192,9194,9210-9212	J02245102	" "	" "	1kΩ	
			DIODE						
D9034-9036,9047	G2090029	Ge	1N60	R9173	J02245152	" "	" "	1.5kΩ	
D9045,9046	G2090093	"	1N270	R9028,9051,9068,9095,9127,9156,9189,9190	J02245182	" "	" "	1.8kΩ	
D9024	G2090165	Varactor	FC52M-5	R9023,9037,9158,9176	J02245222	" "	" "	2.2kΩ	
D9002-9023,9025-9033,9037,9038,9040-9044,9048-9051	G2090027	Si	1SS53	R9131,9170,9177	J02245272	" "	" "	2.7kΩ	
D9054	G2090158	Zener	RD4.7EB2	R9001,9201	J02245332	" "	" "	3.3kΩ	
D9001,9052	G2090197	"	RD9.1EB3	R9145	J02245392	" "	" "	3.9kΩ	
D9039	G2090021	"	YZ033	R9019,9032,9057,9123,9132,9148	J02245472	" "	" "	4.7kΩ	
D9053	G2090118	Schottky barrier	1SS97						
			CRYSTAL						
X9001	H0102470	HC-18/U	19.7475MHz	R9042,9043,9047,9052,9071,9076,9081,9108,9111,9187,9199	J02245562	" "	" "	5.6kΩ	
			CRYSTAL FILTER						
XF9001	H1102036A	XF-8.9JE		R9064,9069,9143,9157	J02245822	" "	" "	8.2kΩ	
XF9005	H1102040	XF-8.9KS		R9004,9011,9017,9082,9084,9093,9094,9116,9128,9133,9135,9137,9153,9163,9164,9166,9168,9181,9196	J02245103	" "	" "	10kΩ	
XF9007	H1102042	XF-10.7KS							
XF9002(OPTION)	H1102037	XF-8.9KCN	CW(N)						
XF9003(")	H1102038	XF-8.9KC	CW(M)						
XF9004(")	H1102039	XF-8.9KA	AM						
XF9006(")	H1102041	XF-10.7KC	CW(M)						
			THERMISTOR						
TH9001	G9090002	D22A		R9086,9107	J02245123	" "	" "	12kΩ	
TH9002	G9090011	SDT1000		R9021,9059,9085,9129,9134,9136,9202	J02245153	" "	" "	15kΩ	
TH9003,9004	G9090021	D91A							

REPAIR PARTS

R9002,9087,9140	J02245183	Carbon Film 1/4W SJ 18kΩ	C9049,9057,9074,9091,9092,9097,9098,9102,9103,9107,9125,9129,9167,9169,9181,9186,9187,9194-9196	K13170102	Ceramic Disc 50WV SL (DB200YF102Z5L2) 0.001μF
R9012,9054,9063,9165,9172,9178,9183,9184,9203	J02245223	" " " " 22kΩ			
R9018,9022	J02245273	" " " " 27kΩ			
R9026	J02245333	" " " " 33kΩ			
	J02245393	" " " " 39kΩ			
R9015,9125,9213	J02245473	" " " " 47kΩ			
R9038,9160,9208	J02245563	" " " " 56kΩ			
R9039	J02245683	" " " " 68kΩ			
R9195,9209	J02245823	" " " " 82kΩ			
R9010,9030,9062,9090,9138,9139,9142,9149	J02245104	" " " " 100kΩ			
R9117	J02245154	" " " " 150kΩ			
R9144,9151	J02245184	" " " " 180kΩ			
R9126,9147	J02245224	" " " " 220kΩ			
R9113,9121	J02245274	" " " " 270kΩ			
R9155	J02245474	" " " " 470kΩ			
R9020,9146,9150,9152	J02245105	" " " " 1MΩ			
R9130	J02245225	" " " " 2.2MΩ			
		POTENTIOMETER			
VR9001	J50749501	H0812A001-500B 500ΩB	C9063,9133,9197	K13170473	" " 50WV 0.047μF (DB207YF473Z5L5)
VR9002,9005	J51740501	EVNB3AA00B52 500ΩB			
VR9003,9004	J50749502	H0812A004-5KB 5kΩB	C9015	K50177102	Mylar " 0.001μF (50F2U102M)
VR9006	J50749203	H0812A006-20KB 20kΩB			
		CAPACITOR			
	K02179004	Ceramic Disc 50WV CH 3pF (DD104CH030C50V02)	C9019,9142	K50177223	" " 0.022μF (50F2U223M)
	K06173060	" " " " UJ 6pF (DD104UJ060J50V02)	C9124,9143	K40179013	Electrolytic " 1μF (50RE1)
	K06173080	" " " " 8pF (DD104UJ080D50V02)	C9123	K40179011	" " 3.3μF (50RE3R3)
C9056,9118	K00173100	" " " " SL 10pF (DD104SL100D50V02)	C9127	K40149001	" 25WV 4.7μF (25RE4R7)
C9008,9111	K00175220	" " " " 22pF (DD104SL220J50V02)	C9006,9016,9093,9113,9116,9131,9139,9140,9191	K40129004	" 16WV 10μF (16RE10)
	K02179010	" " " " CH 24pF (DD104CH240J50V02)	C9120	K40129016	" " 22μF (16RE22)
C9155	K00175270	" " " " 27pF (DD104SL270J50V02)	C9126	K40129002	" " 47μF (16RE47)
C9034	K02175390	" " " " 39pF (DD105-257CH390J50V02)	C9143	K40109002	" 10WV 47μF (10RE47)
C9068	K02175470	" " " " 47pF (DD106CH470J50V02)	C9160	K40129007	" " 100μF (16RE100)
C9070,9072	K00175470	" " " " SL 47pF (DD104SL470J50V02)	C9135	K70167684	Tantalum 35WV 0.68μF (CS15E1VR68M)
C9033	K02175680	" " " " CH 68pF (DD107CH680J50V02)	C9134	K70167105	" " 1μF (CS15E1V010M)
C9069	K02175470	" " " " 47pF (DD106CH470J50V02)			
		TRIMMER CAPACITOR			
		(DD107CH101J50V02)		K91000087	ECV1ZW10x60 10pF
C9121	K00175101	" " " " SL 100pF (DD105SL101J50V02)			
C9158	K10176101	" " " " B 100pF (DD104B101K50V02)			INDUCTOR
C9062	K06175101	" " " " UJ 100pF (DD106UJ101J50V02)	L9002	L1190111	FL4H-5R6K 5.6μH
C9198,9199	K06175121	" " " " 120pF (DD107UJ121J50V02)	L9042,9043,9047,9048	L1190023	FL5H-220K 22μH
C9117	K00175221	" " " " SL 220pF (DD107SL221J50V02)	L9001,9003-9038,9041,9044-9046,9049-9059	L1190020	FL5H-151K 150μH
C9001-9004,9011,9022,9023,9035	K13170102	" " " " 0.001μF (DB200YF102Z5L2)	L9039,9040	L1190017	FL5H-102K 1mH

REPAIR PARTS

C2306	K06179006	Ceramic Disc 50WV UJ 30pF (DD104UJ300J50V02)	C2706,2707	K70167334	Tantalum 35WV 0.33μF (CS15E1VR33M)
C2309	K02179016	" " " CH 51pF (DD106CH510J50V02)	C2704	K40120226	Electrolytic 16WV 22μF (16RL22)
C2310	K02179027	" " " " 270pF (DD112CH271J50V02)			
C2301,2302,2305, 2307,2308,2311, 2313,2314	K14180103	" " 63WV 0.01μF (RD871-1F2-103Z)	MJ2701	P0090037	CONNECTOR 5048-8A
		TRIMMER CAPACITOR			
TC2301	K91000028	ECV-1ZW 10x53N 10pF	RAM BOARD UNIT (OPTION)		
TC2302	K91000059	ECV-1ZW 04x53N 4pF	Symbol No.	Part No.	Description
TC2303	K91000029	ECV-1ZW 20x53N 20pF	PB-2267	F0002267	Printed Circuit Board
				C0022670	P.C.B with Components
		INDUCTOR			
L2301-2303	L1190029	FL5H-470K 47μH			
L2304,2305	L1190020	FL5H-151K 150μH			IC
			Q7901,7902	G1090368	MN1203
	Q5000036	TP terminal G			
					DIODE
			D7901	G2090027	Si 1SS53
					RESISTOR
			R7901,7902	J01245224	Carbon Film 1/4W TJ 220kΩ
					BLOCK RESISTOR
			RB7901	J40900027	RA1/16 220KΩ7A 1/16W 220kΩx7
		IC			
Q2701	G1090223	8044			CONNECTOR
			J7901	P0090092	3022-08A
			J7902	P0090090	3022-09A
		TRANSISTOR			
Q2702	G3318150Y	2SC1815Y			
		DIODE			
D2701-2706	G2090029	Ge 1N60			
					FM UNIT (OPTION)
			Symbol No.	Part No.	Description
		RESISTOR	PB-2254	F0002254	Printed Circuit Board
R2705	J02245102	Carbon Film 1/4W SJ 1kΩ		C0022540	P.C.B with Components
R2704	J02245332	" " " " 3.3kΩ			
R2709,2710	J02245103	" " " " 10kΩ			
R2701,2702,2707	J02245104	" " " " 100kΩ			
			Q2109	G1090246	AN6552
			Q2118	G1090080	μPC78L08
			Q2104	G1090072	μPC577H
VR2702	J51723104	SR19R 100kΩB			
		POTENTIOMETER			
					TRANSISTOR
		CAPACITOR	Q2103,2105,2107, 2110-2117	G3309451P	2SC945AP
C2703	K13170473	Ceramic Discs 50WV 0.047μF (DB207YF473Z5L5)	Q2108	G3309451Q	2SC945AQ
C2701,2702	K50177104	Mylar " " 0.1μF (50F2U104M)	Q2101	G3316740L	2SC1674L
C2705	K70167224	Tantalum 35WV 0.2μF (CS15E1VR22M)	Q2106	G3319590Y	2SC1959Y

		FET		R2144,2168,2173, 2175,2180,2182	J02245223	Carbon Film 1/4W SJ 22kΩ
Q2102	G3090035	2SK19TM-GR				
				R2109,2131,2140, 2179	J02245273	" " " " 27kΩ
		DIODE		R2136	J02245473	" " " " 47kΩ
D2101,2102,2105, 2106	G2001880F	Ge	1S188FM	R2150	J02245683	" " " " 68kΩ
				R2145	J01245683	" " " " TJ 68kΩ
				R2146	J02245823	" " " " SJ 82kΩ
D2107,2108	G2090027	Si	1SS53	R2107,2124,2141, 2163	J02245104	" " " " 100kΩ
D2109	G2090210	Varactor	FC63-4			
D2110	G2090006	"	MV13			
D2104	G2090042	Zener	RD8.2EB3	R2138	J02245274	" " " " 270kΩ
D2103	G2090155	"	RD9.1EB3	R2165	J02245334	" " " " 330kΩ
		CRYSTAL				THERMISTOR
X2101	H0102275	HC-18/U	9442.5kHz	TH2101	G9090001	SDT-250
X2102	H0100440	HC-18/U	8987.5kHz			
		CERAMIC FILTER				POTENTIOMETER
CF2101	H3900200	CFW455E		VR2107	J50716201	RV8FAS200ΩB 200ΩB
				VR2106	J51740501	EVN-B3AA00B52 500ΩB
				VR2105	J51740102	EVN-B3AA00B13 1kΩB
				VR2104	J51740502	EVN-B3AA00B53 5kΩB
		CERAMIC DISCRIMINATOR				
CD2101	H7900040	SFD455S4		VR2102	J50716502	RV8FAS5KB 5kΩB
				VR2103	J50716103	RV8FAS10KB 10kΩB
				VR2101	J50716104	RV8FAS100KB 100kΩB
		RESISTOR				CAPACITOR
R2127	J02245100	Carbon Film	1/4W SJ 10Ω			
R2153,2158	J02245330	" "	" " 33Ω	C2110	K00173070	Ceramic Disc 50WV SL 7pF (DD104SL070D50V02)
R2149	J02245470	" "	" " 47Ω			
R2101,2171	J02245560	" "	" " 56Ω	C2166	K06175150	" " " " UJ 15pF (DD104UJ150J50V02)
R2154,2172	J02245680	" "	" " 68Ω			
R2120	J02245820	" "	" " 82Ω	C2171	K00179005	" " " " SL 20pF (DD104SL200J50V02)
R2106,2110,2117, 2125,2160,2162, 2186	J02245101	" "	" " 100Ω	C2126	K06175220	" " " " UJ 22pF (DD104UJ220J50V02)
R2166	J02245221	" "	" " 220Ω	C2170,2172	K00175121	" " " " SL 120pF (DD104SL121J50V02)
R2134	J02245271	" "	" " 270Ω			
R2104,2116,2118, 2128,2184	J02245471	" "	" " 470Ω	C2128,2129	K06175151	" " " " UJ 150pF (DD1071UJ15J150V02)
R2130	J01245471	" "	" " TJ 470Ω	C2127	K00175221	" " " " SL 220pF (DD107SL221J50V02)
R2159	J02245561	" "	" " SJ 560Ω			
R2111,2126,2135, 2142,2152,2170, 2181	J02245102	" "	" " 1kΩ	C2148,2152	K19149005	Semiconductor Ceramic 25WV 0.0022μ (UAT04X222K-L05AE)
R2108	J10246102	Carbon Composition	1/4W GK 1kΩ	C2101,2122	K13170102	Ceramic Disc 50WV 0.001μ (DB200YF102Z5L2)
R2112,2143,2148, 2167	J02245152	Carbon Film	1/4W SJ 1.5kΩ	C2136,2145,2150	K19149009	Semiconductor Ceramic 25WV 0.0047μ (UAT05X472K-L05AE)
R2133	J02245182	" "	" " 1.8kΩ			
R2119,2123 2129	J02245222	" "	" " 2.2kΩ	C2102-2106, 2108,2109,2112, 2115,2130,2131, 2158,2164,2165, 2169,2173	K14180103	Ceramic Disc 63WV 0.01μ (RD871-1FZ103Z)
R2155,2176 R2185	J02245272	" "	" " 2.7kΩ			
R2156,2157,2169	J02245332	" "	" " 3.3kΩ	C2122,2124,2134, 2142	K19149017	Semiconductor Ceramic 25WV 0.022μ (UAT06X223K-L45AE)
R2105,2113,2132, 2183	J02245472	" "	" " 4.7kΩ			
R2102,2121,2122, 2161,2164	J02245562	" "	" " 5.6kΩ	C2116-2118, 2125,2144,2161, 2162	K19149021	" " " " 0.047μ (UAT08X473K-L45AE)
R2151	J02245822	" "	" " 8.2kΩ			
R2115,2147,2178	J02245103	" "	" " 10kΩ	C2107,2111,2114, 2119,2120	K19149025	" " " " 0.1μF (UAT13X104K-L46AE)
R2174	J02245123	" "	" " 12kΩ			
R2139,2177	J02245153	" "	" " 15kΩ	C2123	K70167224	Tantalum 35WV 0.22μ (CS15E1VR22M)
R2103,2114,2137	J02245223	" "	" " 22kΩ			

**FT-ONE
CIRCUIT DIAGRAM**

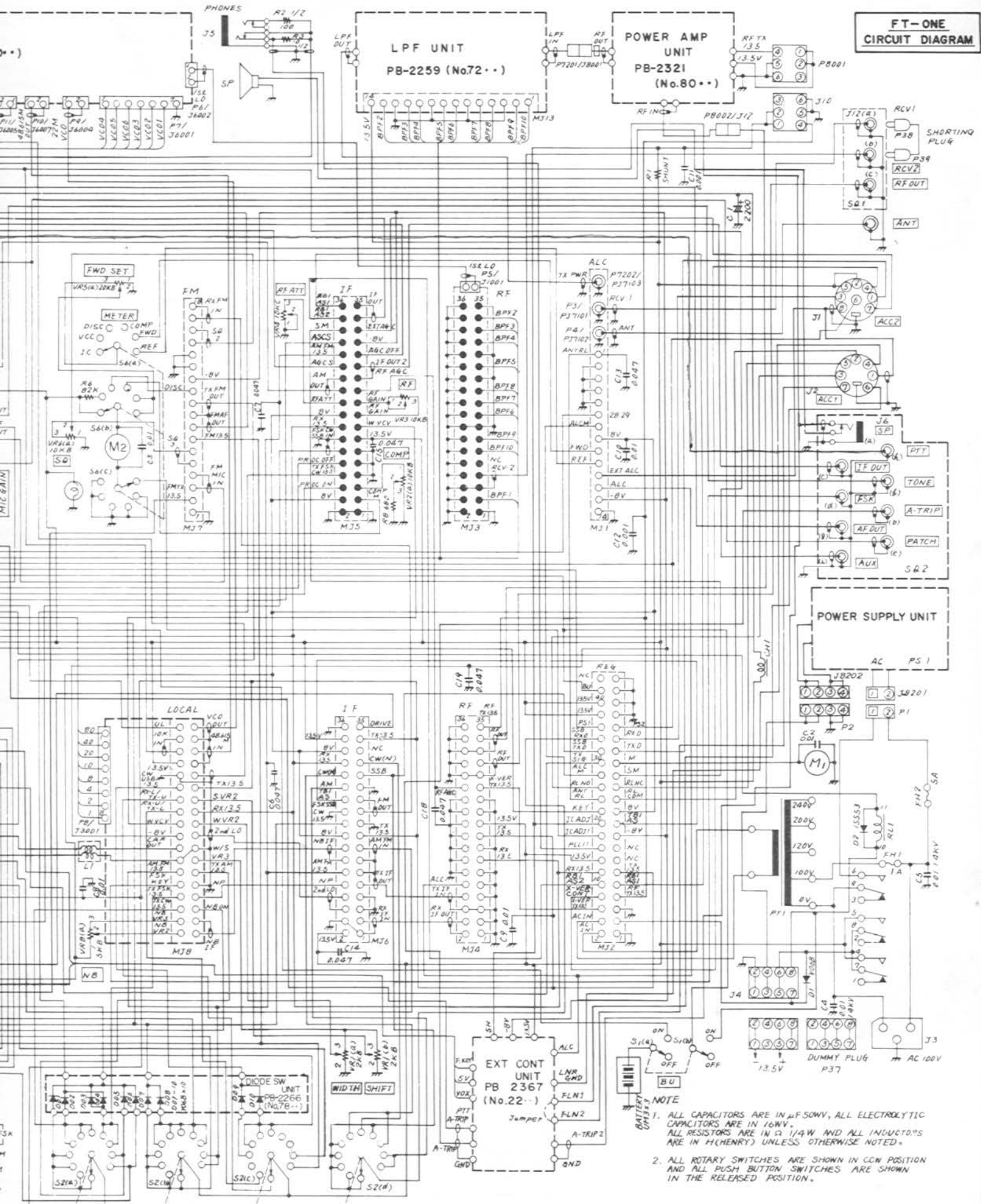

NOTE

1. ALL CAPACITORS ARE IN μ F 50V, ALL ELECTROLYTIC CAPACITORS ARE IN 16V. ALL RESISTORS ARE IN Ω 1/4W AND ALL INDUCTORS ARE IN H (HENRY) UNLESS OTHERWISE NOTED.
2. ALL ROTARY SWITCHES ARE SHOWN IN CW POSITION AND ALL PUSH BUTTON SWITCHES ARE SHOWN IN THE RELEASED POSITION.

