

**INSTRUCTION  
MANUAL  
FT-221 R**

**YAESU MUSEN CO., LTD.**

TOKYO JAPAN

## TABLE OF CONTENTS

	(Page)
GENERAL DESCRIPTION .....	1
SPECIFICATION .....	2
INSTALLATION .....	4
CONTROLS AND SWITCHES .....	6
REAR PANEL CONNECTIONS .....	8
OPERATION .....	9
BLOCK DIAGRAM .....	13
CIRCUIT DESCRIPTION .....	14
ALIGNMENT AND MAINTENANCE .....	25
RESISTANCE VOLTAGE CHART .....	32
PARTS LIST .....	38

This manual is revised for the units produced starting with Lot No. 009 and the lots produced subsequently.

Copyright of  
Yaesu Musen Co. Ltd.

# FT-221R VHF TRANSCEIVER

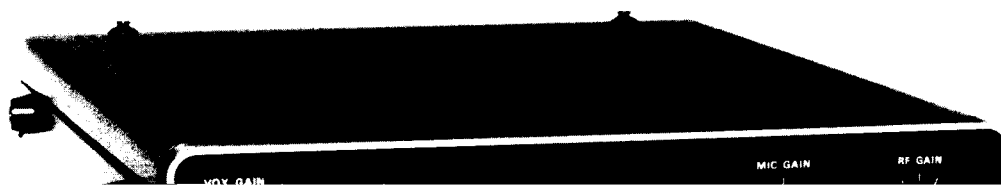

# SPECIFICATIONS

## GENERAL

### Frequency Range:

144.0 ~ 144.5 MHz  
144.5 ~ 145.0 MHz  
145.0 ~ 145.5 MHz  
145.5 ~ 146.0 MHz  
146.0 ~ 146.5 MHz  
146.5 ~ 147.0 MHz  
147.0 ~ 147.5 MHz  
147.5 ~ 148.0 MHz

### Frequency Readout:

Better than 1 kHz

### Emission:

SSB (LSB or USB selectable), AM, FM and CW.

### Power Output:

SSB 12 Watts PEP  
FM, CW 14 Watts  
AM 2.5 Watts

### Frequency Stability:

Within 100 Hz during any 30 minute period after warm up. Not more than 20 Hz with a 10% line voltage variation.

### Antenna Impedance:

50 ohms unbalanced

### Repeater Burst Signal:

1500 to 2000 Hz adjustable

### Repeater Split

600 kHz and any frequency up to 1 MHz

### Power Requirement:

AC 100/110/117/200/220/234 volts  
50/60 Hz  
DC +12 ~ 14.5 Volts, negative ground

### Power Consumption:

AC Receive 30VA  
Transmit 90VA at 10 watts output  
DC Receive 0.6A  
Transmit 3A at 10 watts output

### Size:

280 (W) x 125 (H) x 295 (D) m/m

### Weight:

Approx. 8.5 kg

## RECEIVER

### Sensitivity:

SSB/CW 0.5  $\mu$ V for 10 dB S/N  
FM 0.75  $\mu$ V for 20 dB QS  
AM 1.0  $\mu$ V for 10 dB S/N

### Selectivity:

SSB/CW/AM 2.4 kHz at 6 dB  
4.1 kHz at 60 dB  
FM  $\pm$ 6 kHz at 6 dB  
 $\pm$ 12 kHz at 60 dB

### Image Ratio:

Better than - 60 dB

### Spurious Response:

Better than 1  $\mu$ V at antenna input

### Speaker Impedance:

4 ohms

### Audio Output:

2 Watts at 10% distortion

## TRANSMITTER

### Audio Response:

300 ~ 2700 Hz  $\pm$ 3 dB

### Carrier Suppression:

40 dB or better

### Unwanted Sideband Suppression:

40 dB or better at 1 kHz

### Spurious Radiation:

Down 60 dB or better

### FM Deviation:

Maximum 12 kHz: Factory set at  $\pm$ 5 kHz

## SEMICONDUCTOR COMPLEMENT

### Transistors:

2SD114	1	2SC735Y	3
2SD313D	3	2SC711	1
2SC372Y	35	2SA695	1
2SC784R	5	2SD359	1
2SC373	3	2SB529	1
MPSA13	2	2SC1000GR	2
2SC741	1	2N5590	1
2SC730	1	2N5591	1

### Programmable Unijunction Transistor:

N13T1	1
-------	---

### Diodes:

DS-130YD	1	WZ-110	2
1S1555	57	1N4740	1
10D1	7	GD-1	1
M4B-5	1	RD-1	1
1S188FM	13	TLR-108	1
1S1007	12	1SV50	3
WZ-061	2	1S2209	12
WZ-090	1		

### FETs:

2SK19GR	15	3SK51	1
2SK19Y	2		

### Thyristor:

CW-01B	1
--------	---

### Integrated Circuits:

$\mu$ A703HC	2	TP4011AN	5
LD3001	2	34024PC	1
TA7061AP	1	TA7045M	1
TP4049AN	1	TP4027AN	1

### Varistor:

MV-5W	1
-------	---

The FT-221R is supplied complete with all cables, connectors, fuses and microphone as shown below.

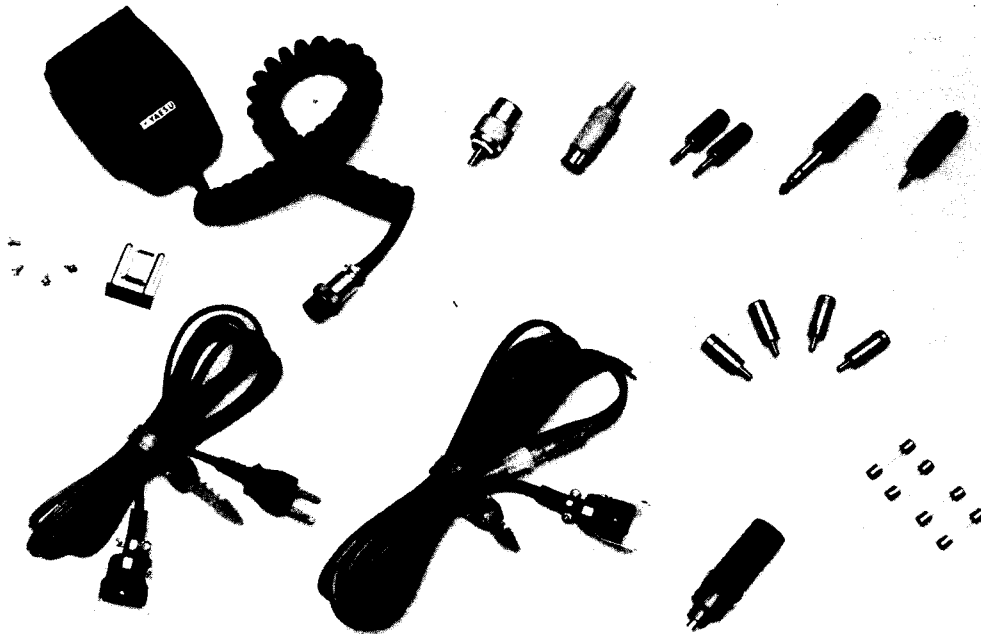

Figure 1

# INSTALLATION

## GENERAL

The FT-221R transceiver has been designed primarily for base service, requiring only an antenna. However, the transceiver provides for efficient mobile service. The transceiver has been factory pre-tuned and requires no adjustment for normal operation into a matched 50 ohm load.

The antenna and its location are the most important consideration in both base and mobile installations, where effective communication range

Be sure that a proper fuse is used according to the local supply voltage: 2 amps for 117 volts and 1 amp for 220 volts. The transceiver should be connected to a good ground. The ground lead should be connected to the terminal marked GND located on the rear panel of the transceiver.

It is recommended that excessively warm locations be avoided. The transceiver should be placed in a location that has adequate space to permit free air

is directly related to antenna height. The antenna should always be as high and in the clear as possible, and a minimum distance of 5 feet should be maintained between the VHF and other antennas. In a mobile installation, it is advisable to locate the antenna as far from the engine as practical in order to minimize any ignition noise pickup. In all installations, the most popular antenna types are either a 1/4 wave length whip with unity gain or a 5/8 wave length whip with a base matching device affording approximately 3.5 dB gain. Our mobile antenna, RSL-145, is available through your dealer.

To minimize loss in the antenna system, use the shortest length of coaxial cable that is practical, avoiding any sharp angles or kinks. Use type RG-8/U cable if the transmission line length exceeds 25 feet, while RG-58/U may be used for shorter lengths.

## BASE STATION INSTALLATION

The transceiver is designed for use in many areas of the world where the supply voltage may differ from the operator's local supply voltage. Therefore, before connecting the AC cord to the power outlet, be sure that the voltage marked on the rear of the transceiver agrees with the local AC supply voltage. If not, please refer to Page 5 for rewiring of the transformer primary connections.

## CAUTION

circulation through the cabinet openings.

## MOBILE INSTALLATION

The transceiver will operate satisfactorily from any 12 volt negative ground battery source by connecting the DC power cord to the rear panel receptacle. In the car, a location should be selected that is clear of heater ducts to protect it from excessive heat. No special mounting precautions need to be observed if adequate ventilation space is available. A minimum of two inches air space above the cabinet top and on all sides is recommended to allow proper air flow around the cabinet. You may put it on the seat but be sure that there is clearance between the transceiver bottom and seat. Since the transceiver requires an average of 3 amps on transmit, the fuse in the DC power cable should be rated at 5 amps.

When making connections to the car battery, be certain that the RED lead is connected to the positive (+) terminal and the BLACK lead to the negative (-) terminal of the battery. Reversed connection could permanently damage the transceiver. The BLACK lead should run directly to the negative terminal of the battery. The power cable should be kept away from ignition wires and be as short as possible to minimize voltage drop and to provide a low impedance path from the transceiver to the battery.

Prior to operating the transceiver in a mobile installation, the voltage regulator setting should be

voltage. As the battery and regulator age, the maximum voltage while charging can increase to a very high level which is not only detrimental to the battery but could cause damage to the transceiver.

The transceiver is designed to operate from a source voltage range of 11 to 14 volts. It is necessary to carefully set the regulator so that the highest charging voltage does not exceed 14 volts. The transceiver should be switched "OFF" when the vehicle is started in order to prevent voltage transients from damaging the transistors.

It is recommended that the microphone furnished with this transceiver be used, however any other microphone of 500 ~ 600 ohm impedance may be used. Refer to Figure 2 for the microphone plug connections. The microphone bracket may be put on the side of the cabinet. It may also be put at any convenient place by making two 2.5 m/m holes spaced 14 m/m.

A speaker is built into the transceiver, however the audio output is also available for an external speaker use. Any speaker having a 4 ohm impedance may be used and when the external speaker plug is plugged into the EXT SP jack on the rear panel, the built-in speaker is disabled.

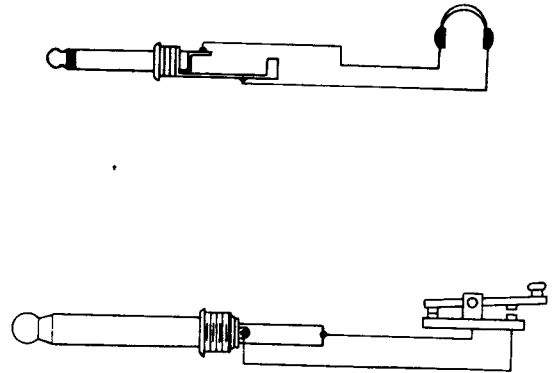
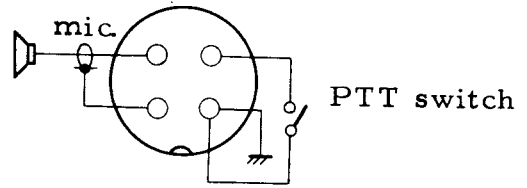

Figure 2: Connection

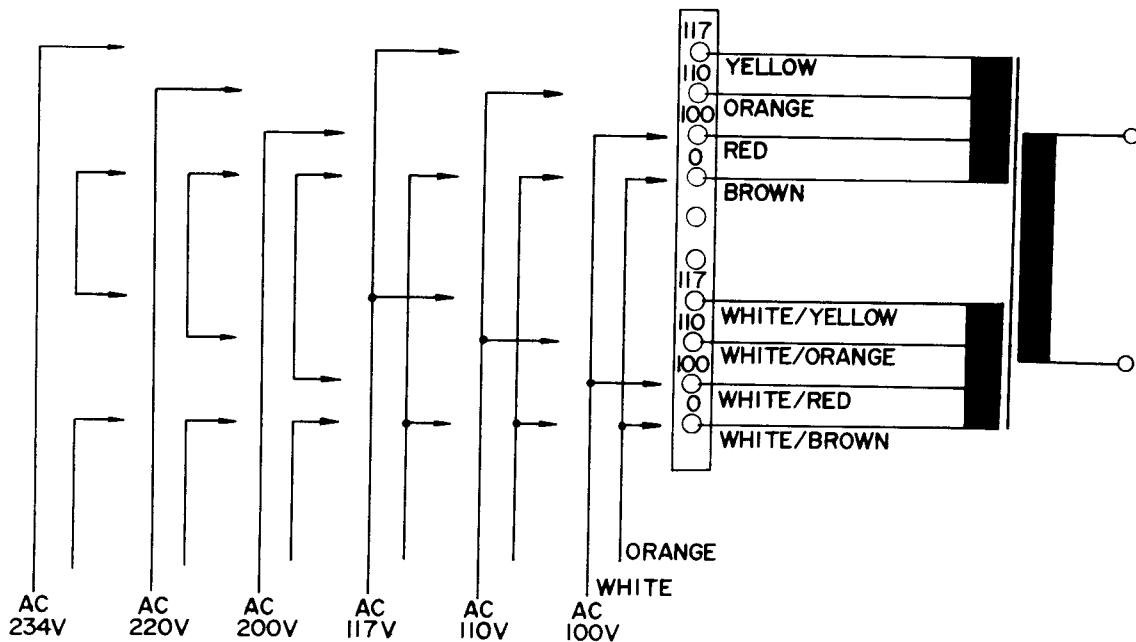

Figure 3: Transformer Primary Wiring

## CONTROLS AND SWITCHES

The transceiver has been specifically designed for flexible operation and versatility. All internal controls have been preset at factory. Several of the controls are unusual in operation, and improper adjustment may result in poor quality signals. The

various front panel controls and their functions are described in the following section. Be certain that you thoroughly understand the function of each control before operating the transceiver.

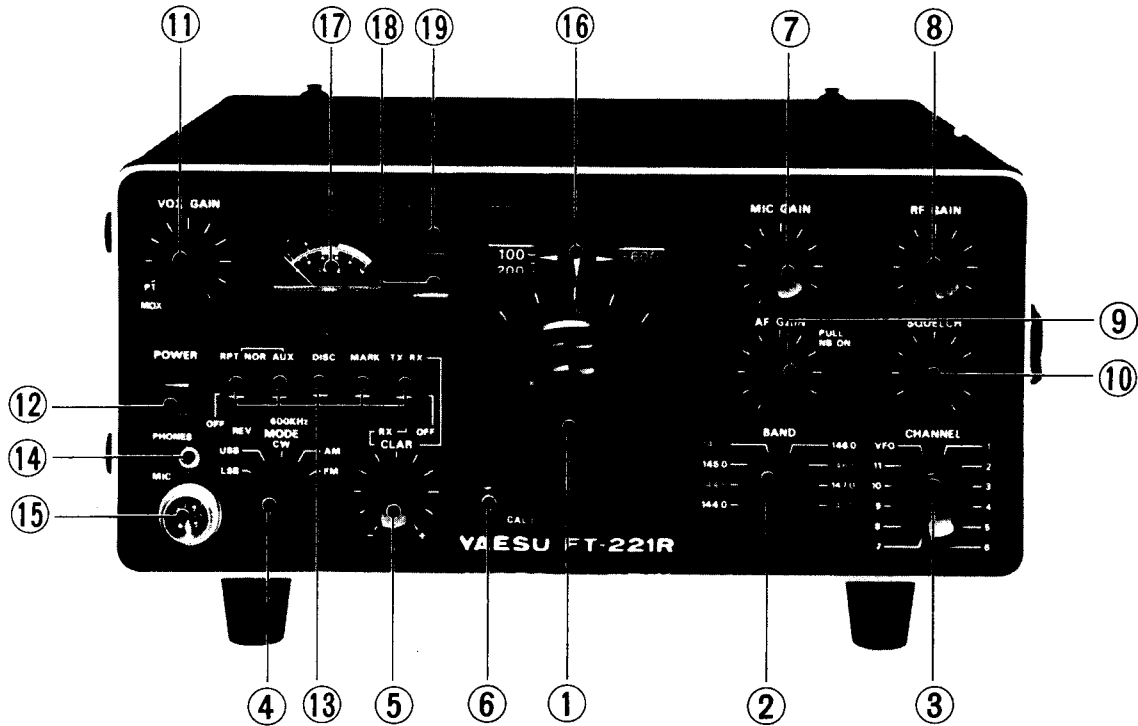

Figure 4 : Front Panel Controls & Switches

### (1) MAIN TUNING control

The tuning knob, located below the dial window, determines the actual frequency of operation in combination with the BAND switch. A dual rate, concentric dial drive system is employed for a coarse and fine setting of the operating frequency.

### (2) BAND switch

The BAND switch is an eight-position switch that selects one of the 500 kHz segments in two meter amateur band.

These segments are:

144.0	: 144.0 ~ 144.5 MHz
144.5	: 144.5 ~ 145.0 MHz
145.0	: 145.0 ~ 145.5 MHz
145.5	: 145.5 ~ 146.0 MHz
146.0	: 146.0 ~ 146.5 MHz
146.5	: 146.5 ~ 147.0 MHz
147.0	: 147.0 ~ 147.5 MHz
147.5	: 147.5 ~ 148.0 MHz

### (3) CHANNEL switch

The CHANNEL switch selects one of 11 crystals for crystal controlled operation. This switch also selects the VFO for continuous tuning with the main tuning knob.

### (4) MODE switch

The MODE switch is a five-position switch. This switch selects the mode of operation: LSB (lower side band SSB), USB, (upper side band SSB), CW (code operation), AM (amplitude modulation) and FM (frequency modulation).

### (5) CLARIFIER control

The CLARIFIER control provides a means of OFF setting the receiver frequency approximately 4 kHz to either side of the transmitting frequency. Thus it is possible to set the pitch of the voice or signal you are receiving to the most readable point without affecting your transmitting frequency. Its

use is particularly valuable in "net" operation when several participants may be transmitting

In the NOR (normal) position, the transmitter frequency shifts 600 kHz down and in

# REAR PANEL CONNECTIONS

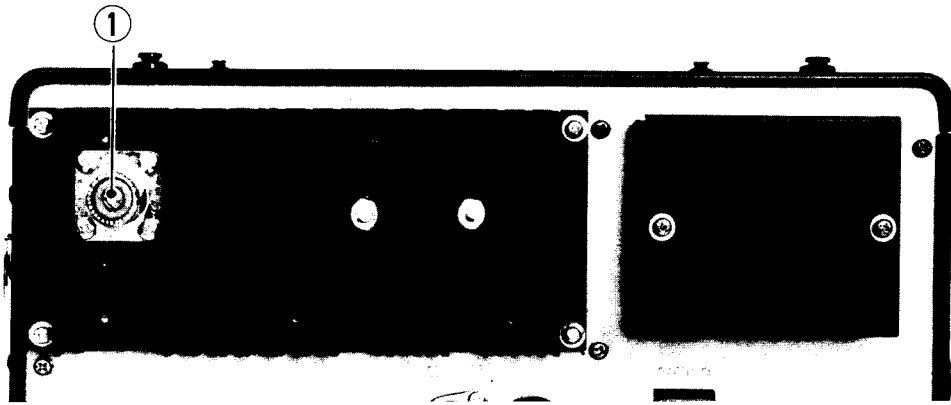

# OPERATION

The tuning procedure of the transceiver is not complicated, however care should be exercised when tuning to insure peak performance of the equipment. The following paragraphs describe the procedure for receiver and transmitter tuning.

## INITIAL CHECK

Before connecting the transceiver to a power source, carefully examine the unit for any visible damage. Check that all modules and crystals are firmly in place and that controls and switches are operating normally. Ensure that voltage specification marked on the rear panel matches the supply voltage.

## DIAL READOUT

The main tuning dial is color coded with the band selector switch for proper frequency readout. When the band selected is marked in white on the transceiver front panel, the operator reads the white scale on the main tuning drum. When the band selected is marked in amber the operator reads the amber scale. The main tuning drum is marked in 50 kHz increments. This provides a coarse frequency setting within the band. The round subdial on the dial window surrounding the tuning knob is scaled in 1 kHz increments and provides fine settings of the transceiver operating frequency. The following example will familiarize yourself with the relationship of main and subdial frequency readout.

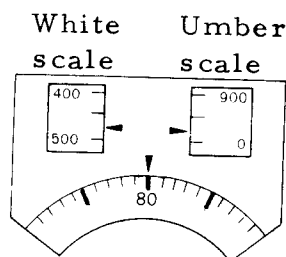

Figure 7

Read the white scale on main dial for the bands 144.0, 145.0, 146.0 and 147.0, and amber scale for 144.5, 145.5, 146.5 and 147.5.

Then the setting shown in the example would be 144.480 MHz on 144.0 BAND switch setting, and 145.480 MHz on 145.0. And also the frequency would be 144.980 MHz on 144.5 BAND switch setting, and 145.980 MHz on 145.5.

## RECEIVER

After the transceiver is properly set up for operation, set the controls and switches as follows;

- POWER . . . . . Down to "OFF" position.
- MODE . . . . . Desired mode.
- BAND . . . . . Desired band.
- RPT . . . . . Lever position horizontal to OFF position.
- AUX-600 kHz . . . . . Lever position horizontal to 600 kHz shift
- DISC . . . . . Lever position horizontal to OFF position.
- MARK . . . . . Lever position horizontal to OFF position.
- CALR . . . . . Lever position horizontal to OFF position.
- NOR-REV . . . . . "NOR" position.
- MAIN TUNING DIAL . . . . . Desired operating frequency.
- VOX GAIN . . . . . PTT.
- AF GAIN . . . . . Desired audio level.
- RF GAIN . . . . . Fully clockwise position.
- CHANNEL . . . . . VFO.
- SQUELCH . . . . . Fully counter-clockwise position.

Connect the cord supplied to the appropriate power source, and an antenna to antenna connector on the rear panel.

## CAUTION

PERMANENT DAMAGE WILL RESULT IF IMPROPER SUPPLY VOLTAGE IS APPLIED TO THE TRANSCEIVER. WARRANTY DOES NOT COVER THE DAMAGE CAUSED BY IMPROPER SUPPLY VOLTAGE.

Turn on the POWER switch. The dial and meter lamps should light up, and the transceiver is now ready to operate.

### (1) SSB and AM Modes

Using the main tuning control (VFO), tune in an incoming signal. USB (upper side band) is mostly used for 2 meter SSB operation. When the received signal can not be heard clearly, then change to the opposite side band. The RF GAIN control is normally set to the fully clockwise position, but if the incoming signal is extremely strong, it is recommended to turn this control back to prevent overload of the front end. When there is noise caused by automobiles, pull the AF GAIN control out to switch on the NB (noise blanker) in order to eliminate these pulse type noises.

### (2) CW Mode

With the CLARIFIER switch in the OFF position, tune in a signal until an 800 Hz beat tone is heard. Under this condition, your transmitting frequency coincides with the received signal. If you desire to hear a beat tone of your choice, then use the CLARIFIER control.

### (3) FM Mode

Using the tuning control, tune in an incoming signal for a maximum and steady S-Meter reading where a natural voice is heard. For accurate tuning, set the DISC switch to the upper ON position. Carefully readjust the tuning control until the meter indicates zero (half way of the full scale).

If the S-Meter indication wobbles or if a clean audio output is not available, it is very likely that the signal is in the SSB mode. In this case, turn the MODE switch to USB or LSB position, and carefully tune the tuning control until a clear voice is heard. It is important that the CLARIFIER switch be set to the OFF position when calling the another station. After the initial contact is made, then the CLARIFIER may be used for the desired listening sound.

## FREQUENCY CALIBRATION

### (1) SSB Mode

Set the CLARIFIER to the OFF position, and the tuning control to the 100 kHz point on the dial nearest to the desired frequency. Set the MARK switch to the upper position. While pressing the CALIB knob to lock the dial, tune the tuning control for a zero beat. The transceiver must be recalibrated when changing the mode of operation: USB, LSB, AM or CW.

### (2) FM Mode

Set the CLARIFIER to the OFF position, and the tuning control to the 100 kHz point in the round dial nearest to the desired operating frequency. Set the MARK switch and DISC switch to ON position. While pressing the CALIB knob down to lock the dial, tune the main tuning control until the meter indicates the green portion of its scale.

NOTE: WHEN THE MARKER SWITCH IS IN THE "ON" POSITION, THE ANTENNA IS DISCONNECTED FOR EASIER CALIBRATION.

## TRANSMITTER

Connect a 50 ohm dummy load or a matched antenna to the coaxial fitting on the rear panel. Since the transmitter section utilizes wide band techniques no tuning control is necessary except the main tuning control to select the operating frequency. Plug the microphone into the MIC jack and select the desired mode. Push down the PTT (push-to-talk) switch on the microphone and speak into the microphone.

### (1) SSB Mode

The meter indicates maximum deflection on voice peak and zero with no microphone input. Release the PTT switch for receive. Excessive setting of the MIC GAIN will result in poor quality transmitted signals.

### (2) AM Mode

When the PTT switch is depressed, the proper amount of carrier is automatically inserted. Adjust the MIC GAIN control until the meter indicates a very slight movement with voice peaks while speaking into the microphone normally.

(3) CW Mode

Di... into the KEY lock on the...

relay sensitivity and this control has been preset at factory. These controls are located on the AF AMP

6 to 8 relative power output, and with the key up, the receiver will recover. The break-in delay time may be adjusted with VR<sub>601</sub>, under the top cover.

(4) FM Mode

Set the MIC GAIN control to the 12 o'clock posi-

**REPEATER OPERATION**

Transmitting and receiving frequencies may be shifted 600 kHz for repeater operation. When the REPEATER switch is ON (upward position) with NOR-REV switch in the NOR (normal) position,

the amateur bands with repeater switch ON. The most repeaters use 600 kHz split between transmitter and receiver frequencies, however, other split than 600 kHz has been adopted in some areas.

When the AUX/600 kHz switch is

The crystal holders accept standard, HC-25/U type crystals. All crystal frequencies must fall between 8,000 kHz and 8,500 kHz. A trimmer capacitor has been connected in series with each crystal to permit proper frequency adjustment. Adjustment

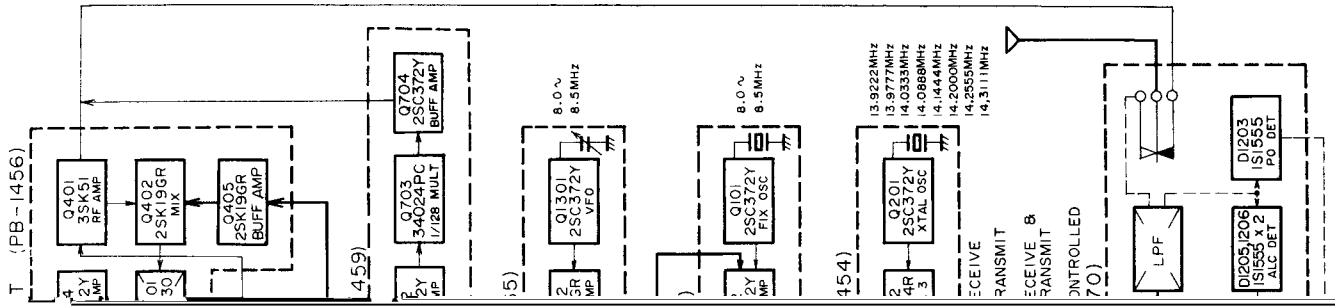

# CIRCUIT DESCRIPTION

## GENERAL

The block diagram and the circuit description that follows will provide you with a better understanding of this transceiver. Computer type plug-in modules have been adopted throughout the transceiver.

The transceiver consists of a single conversion receiver with a 10.7 MHz IF for SSB, CW and AM, a double conversion receiver with a 10.7 MHz first IF and 455 kHz second IF for FM. A single conversion transmitter, utilizing a 10.7 MHz high frequency crystal filter for SSB generation and varactor diode frequency modulation on 10.7 MHz crystal oscillator is incorporated.

### NOTE:

The parts number starts with the number shown below the printed board designation. For example, the field effect transistor 3SK51 in RX RF unit PB-1456 is Q<sub>401</sub>.

## RECEIVER

### RX RF UNIT (PB-1456)

The 144 MHz input signal from the antenna is fed through the antenna relay, RL<sub>1201</sub>, to pin 5 of the RX RF unit. The signal is amplified by the RF amplifier Q<sub>401</sub>, 3SK51 field effect transistor, and then fed to the gate of the first mixer Q<sub>402</sub>, 2SK19GR, where the input signal is heterodyned with a 133.3 MHz to 137.3 MHz signal, delivered from phase-lock-loop unit, and thus produces an IF signal of 10.7 MHz at the drain circuit of Q<sub>402</sub>.

The input and output circuits of the RF amplifier utilize a double tuned circuit, which is sharply tuned to the center of the band with the varactor diodes, D<sub>401</sub> through D<sub>404</sub>, thus eliminating cross modulation and intermodulation effects.

The IF signal passes through crystal filter XF401, FMT-30, and the SSB, AM and CW signal is then fed to the first IF amplifier Q<sub>404</sub>, 2SC372Y, while the FM signal is fed to Q<sub>403</sub>, 2SC372Y.

The SSB, AM and CW signal amplified by Q<sub>404</sub> is fed through a noise blanker gate diode D<sub>407</sub>, 1S1007, to pin 14, and the FM signal amplified by Q<sub>403</sub> is fed to pin 9.

### SSB IF UNIT (PB-1462)

The SSB, AM and CW signal from pin 14 of the RX RF unit is fed through pin 3 to the SSB IF unit. The signal is fed through the diode switch and a crystal filter, XF-9, to the IF amplifier Q<sub>901</sub>, 2SC784R. The signal is amplified by Q<sub>901</sub> and Q<sub>902</sub>, TA7045M, and then fed to the ring demodulator consisting of D<sub>904</sub> through D<sub>907</sub>, 1S1007, where a carrier signal is applied through pin 32 from the carrier oscillator in the MIC AMP unit.

The audio output is fed through pin 33 and the MODE switch, S3D, to pin 28 of the same unit. The IF signal is further amplified by Q<sub>903</sub>, 2SK19GR, and detected by the AM detector D<sub>910</sub>, 1S188FM, for AM mode. Then the audio signal is fed through pin 25 to the MODE switch S3D.

A part of the IF signal output from Q<sub>903</sub> is rectified by D<sub>908</sub>, 1S1007, and D<sub>913</sub>, 1S1555, for AGC (automatic gain control). The AGC voltage is amplified by Q<sub>904</sub> and Q<sub>905</sub>, 2SC373 and controls the gain of IF amplifier Q<sub>901</sub> and Q<sub>902</sub>. A part of

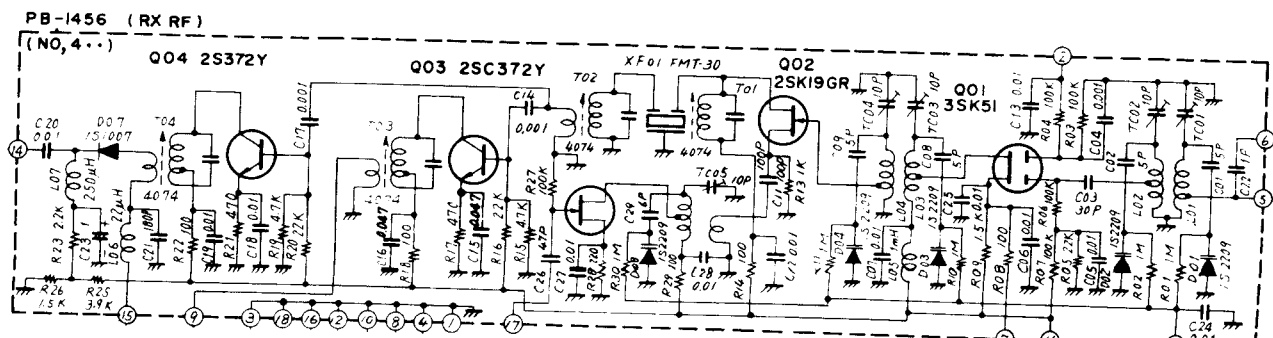



The noise rectifier diodes  $D_{801}$  and  $D_{802}$ , 1S1555, produce a DC voltage which is amplified by following noise pulse amplifier  $Q_{803}$ , 2SK19GR.

Under normal conditions,  $Q_{803}$  conducts producing the cut-off voltage to the base of the gate controller  $Q_{804}$ , 2SC372Y, in turn the high collector voltage of  $Q_{804}$  is supplied from pin 15 to the gate

The DC voltage is also applied from pin 12 to quiet the audio amplifier when the phase lock loop circuit is unlocked.

The speech output from the first microphone amplifier is fed through the VOX GAIN control potentiometer,  $VR_7$ , to the VOX amplifier  $Q_{601}$ , 2SC372Y and  $Q_{602}$ , 1S1555, from pin 2

diode  $D_{407}$ , 1S1007, in the RX RF unit which conducts to pass the signal freely. With pulse noise,  $Q_{804}$  conducts and its collector voltage drops causing the gate diode  $D_{407}$  to disconnect the IF signal during the noise pulse exists.

#### AF AMP UNIT (PB-1499)

The audio signal pre-amplified in the SSB IF unit is fed through pin 13 to the audio amplifier stage consisting of  $Q_{610}$ , 2SC372Y,  $Q_{611}$ , 2SC711,  $Q_{612}$ , 2SA695,  $Q_{613}$ , 2SD359 and  $Q_{614}$ , 2SB529. The audio power amplifier circuit utilizes the OTL (output transformer less) circuitry and delivers 2 watts output to the speaker from pin 8.

The amplified signal is fed to the VOX rectifier,  $D_{601}$  and  $D_{602}$ , 1S1555. The rectified DC voltage is applied to the gate of the VOX relay controllers  $Q_{603}$ , 2SK19Y, and  $Q_{604}$ , 2SC735Y, causing them to conduct and actuate the VOX relay,  $RL_1$ , on the main chassis.

The ANTITRIP circuit provides a threshold voltage to prevent the speaker output from tripping the transceiver into the transmit mode. The receiver audio output voltage is connected through the ANTITRIP potentiometer,  $VR_{603}$ , to the antitrip amplifier  $Q_{605}$ , 2SC372Y, and fed to rectifiers,  $D_{603}$  and  $D_{604}$ , 1S1555. The negative DC output voltage from the rectifier is connected to the gate

In the FM mode, the squelch voltage is applied from pin 12 to the squelch controller  $Q_{607}$ , 2SC372Y, which conducts with noise when the signal is not present, in turn the audio input is grounded to quiet the audio amplifier. When the signal is present, the  $Q_{607}$  is cut-off and permits normal operation of the audio amplifier.

transistor, thus providing the necessary antitrip threshold. The ANTITRIP control,  $VR_{603}$ , adjusts the value of the antitrip voltage threshold so that the speaker output will not produce an excessive positive voltage from the VOX rectifier that exceeds the negative voltage from the antitrip rectifier causing the controller transistor to actuate the relay. When speaking into the microphone, the

positive voltage will exceed the negative antitrip voltage and actuate the relay. VR<sub>602</sub> provides coarse adjustment for relay sensitivity.

Relay hold tone will be determined by the DELAY control potentiometer, VR<sub>601</sub>.

The tone oscillator Q<sub>606</sub>, 2SC372Y, operates when the MODE switch is in the CW position. It is a phase shift oscillator operating at approximately 800 Hz.

The tone output is activated by the keying circuit through the emitter circuit of Q<sub>606</sub> and coupled through sidetone level control, VR<sub>604</sub>, to the receiver audio amplifier, Q<sub>601</sub>, for sidetone monitoring in CW operation. The output from Q<sub>606</sub> is also coupled to the VOX amplifier, Q<sub>602</sub>, for break-in CW operation. In the FM mode, a DC voltage at the discrimination output is applied from pin 17, to the differential amplifier Q<sub>608</sub> and Q<sub>609</sub>, 2SK19GR.

When the frequency of received signal is shifted from the discriminator center, the resulting DC voltage causes either Q<sub>608</sub> or Q<sub>609</sub> to conduct indicating the amount of shift on the meter with the DISC switch in the ON position. VR<sub>605</sub> balances the differential amplifier and VR<sub>606</sub> calibrates the sensitivity of the meter.

## TRANSMITTER

### MIC AMP UNIT (PB-1460)

The speech signal from the microphone is fed from pin 31 to the first microphone amplifier, half of Q<sub>1104</sub>, LD-3001. The input impedance of the microphone amplifier is 600 ohms. This signal is controlled in amplitude by the MIC GAIN control between pins 29 and 31, and is amplified by the second microphone amplifier, the other half of Q<sub>1104</sub>, and applied to the source follower Q<sub>1105</sub>, 2SK19GR, to be delivered to the ring modulator D<sub>1108</sub> through D<sub>1111</sub>, 1S1007.

The carrier oscillator Q<sub>1108</sub>, 2SC372Y, oscillates at 10.7015 MHz for LSB, 10.6985 MHz for USB and 10.6993 MHz for AM/CW depending upon the MODE switch position. In the CW mode, the carrier oscillator oscillates at 10.6993 MHz for transmit and 10.6985 MHz for receive producing an 800 Hz beat note in the receive mode. In the AM mode, the carrier oscillator does not function while receiving. The MODE switch selects the crystal by means of a diode switch. The output from the oscillator is fed through the buffer amplifier Q<sub>1107</sub>, 2SC372Y to the balanced ring modulator D<sub>1108</sub> through D<sub>1111</sub>, 1S1007. The

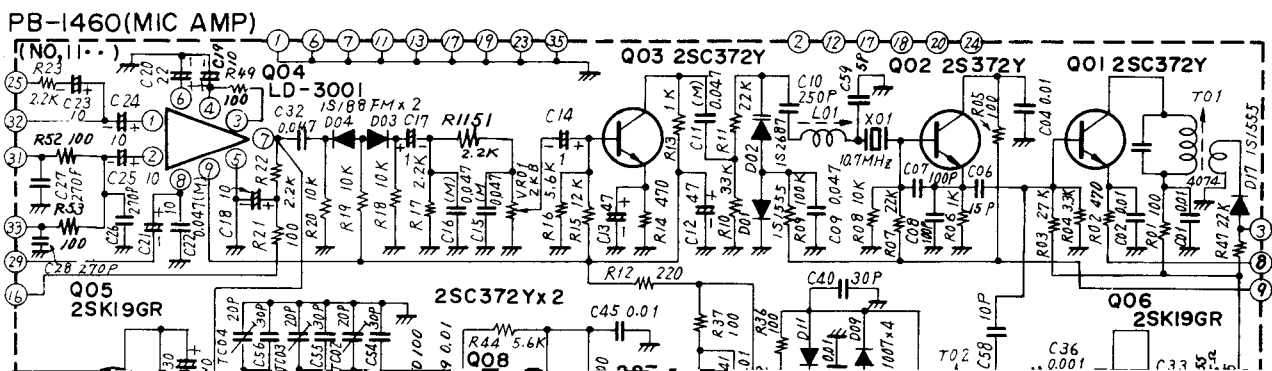

carrier signal output from the buffer amplifier, Q<sub>1107</sub>, is fed from pin 22 to the SSB IF unit for SSB and CW reception. Carrier balance is obtained with potentiometer, VR<sub>1002</sub>, and the trimmer capacitor, TC<sub>1101</sub>. The double side band, suppressed carrier signal is amplified by Q<sub>1106</sub>, 2SK19GR, and fed from pin 10 to pin 5 of the SSB IF unit. In the AM and CW modes, the balanced modulator is unbalanced by the DC

amplified and applied to the modulator, varactor diode D<sub>1102</sub>. The low pass filter limits the transmitter modulation spectrum by attenuating the frequencies above the speech range.

The frequency modulated signal is then amplified by Q<sub>1101</sub>, 2SC372Y, and fed through the output transformer T<sub>1101</sub> to pin 5 of the EXCITER unit.

pletely reducing any spurious radiation. The signal is then amplified by the amplifier chain  $Q_{503}$ ,  $2SC784R$ ,  $Q_{504}$ ,  $2SC741$ , and  $Q_{505}$ ,  $2SC730$ , and delivered from pin 17 to the BOOSTER unit.

The DC voltage for  $Q_{501}$  through  $Q_{504}$  is supplied through  $Q_{506}$ ,  $2SC735Y$ . When the phase lock loop circuit is unlocked, the controller transistor  $Q_{507}$ ,  $2SC372Y$ , stops conducting and in turn  $Q_{506}$  stops supplying the DC voltage for  $Q_{501}$  through  $Q_{504}$ .

The speech signal from pin 27 of the MIC AMP unit is fed through the AM amplifier  $Q_{508}$ ,  $2SC373$ , and emitter follower  $Q_{509}$ ,  $2SC372Y$ , to the AM modulator  $Q_7$ ,  $2SD313D$ , which controls the supply voltage for  $Q_{1201}$ ,  $2N5590$ , in the BOOSTER unit.

#### BOOSTER UNIT (PB-1470)

The signal from EXCITER unit is fed to the BOOSTER unit and amplified by the driver amplifier  $Q_{1201}$ ,  $2N5590$ , and the final amplifier  $Q_{1202}$ ,  $2N5591$ , which delivers 10 watts of RF

of the RF output is rectified by a diode  $D_{1203}$ ,  $1S188FM$ , which delivers a resulting DC voltage to the meter where it provides an indication of relative power output from the transceiver.

The DC voltage obtained from rectifying a small portion of the RF output by the ALC diodes  $D_{1205}$  and  $D_{1206}$ ,  $1S1555$ , which are biased by the ALC threshold control  $VR_{1201}$ , is applied to the gate of  $Q_{906}$  in the SSB IF unit and  $Q_{1106}$  in the MIC AMP unit. This controls their gain in order to automatically control the driving level to the PA transistors in order to prevent any distortion caused by overdrive.

Block diodes  $D_{1207}$  and  $D_{1208}$  disconnect the supply voltage to  $Q_{1202}$  while the antenna is disconnected for marker calibration.

## OTHER CIRCUITS

Some circuits work for both transmitting and receiving and are described as follows:

PLL CIRCUIT: VFO unit PB-1465  
FIX unit PB-1453  
LOCAL unit PB-1454  
PLL unit PB-1455

The FT-221R utilizes a phase lock loop system for the heterodyne oscillator providing a stable signal varying from 133.3 through 137.3 MHz to cover the entire 2 meter band.

### VFO UNIT (PB-1465)

The VFO module board is installed in the VFO chassis. The VFO (variable frequency oscillator)  $Q_{1301}$ , 2SC372Y, generates an 8,000 to 8,500 kHz signal and produces a 500 kHz main tuning dial range. Frequency drift is minimized through the use of a temperature compensation circuit utilizing a differential trimmer capacitor. The signal is fed through the amplifier buffer stage  $Q_{1302}$ , 2SC372Y.

### FIX UNIT (PB-1453)

In addition to normal VFO operation, 11 crystals may be selected for crystal controlled operation with the selector switch located on the front panel of the transceiver.

The FIX channel crystal oscillator  $Q_{101}$ , 2SC372Y, oscillates at the frequency of the crystal selected by the diode switch  $D_{101}$  through  $D_{111}$ , 1S1555. The output is fed from pin 8 through the buffer amplifier  $Q_{102}$ , 2SC372Y, to the PLL unit.

The signal from the VFO also passes through this buffer stage to the PLL unit.

The crystal frequency falls between 8,000 and 8,500 kHz and is determined as follows.

$$f_x = f_0 - f_1$$

where  $f_1$  is given in Table 1 on page 12 and  $f_0$  is the operating frequency.

### LOCAL UNIT (PB-1454)

kHz higher than the normal heterodyne signal when the band switch is set to the 147.0 segment.

A relay, RL<sub>1001</sub> in the tone burst unit is used to select the above crystals with the Repeater switch, S<sub>8</sub>, in the ON position. When the Normal-Reverse switch, S<sub>9</sub>, is set to the NOR position, the relay selects the repeater crystal on transmit that shifts the transmitting frequency down 600 kHz in the 146.5 MHz segment and shifts up 600 kHz in the 147.0 MHz band. The main VFO tuning dial indicates the received frequency.

With S<sub>9</sub> in the REV position, the relay selects the repeater crystal on receive that shifts the receiver frequency down 600 kHz in the 146.5 MHz segment and shifts up 600 kHz in the 147.0 MHz segment. The main tuning dial now indicates the transmitted frequency.

BAND	Crystal No.	Crystal Frequency MHz	Local Frequency MHz
144.0	X <sub>201</sub>	13.9222	125.3
144.5	X <sub>202</sub>	13.9777	125.8
145.0	X <sub>203</sub>	14.0333	126.3
145.5	X <sub>204</sub>	14.0888	126.8
146.5	X <sub>205</sub>	14.1444	127.3
	X <sub>206</sub>	14.2000	127.8
147.0	X <sub>210</sub>	*14.1333	127.2
	X <sub>207</sub>	14.2555	128.3
147.5	X <sub>211</sub>	*14.3222	128.9
	X <sub>208</sub>	14.3111	128.8

\*Repeater for US Model.

Table 2

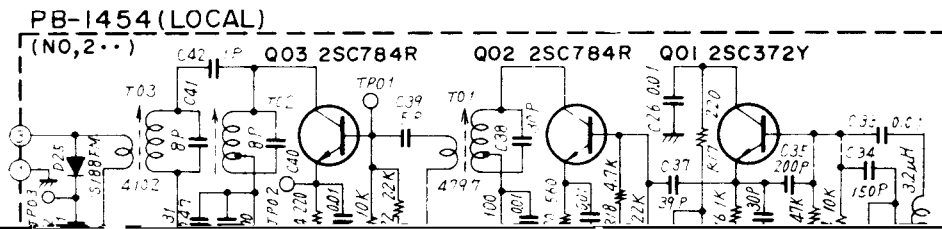

## PLL UNIT (PB-1455)

This unit generates a heterodyne signal for the transmitter and receiver mixer in conjunction with the Phase Lock oscillator.

A voltage controlled oscillator  $Q_{305}$ , 2SK19GR, generates a signal between 133.3 MHz and 137.3 MHz which is determined by  $L_{301}$ ,  $TC_{301}$ ,  $C_{324}$ ,  $D_{305}$  and  $D_{306}$ . The varactor diode,  $D_{305}$ , changes the frequency by the DC voltage which is delivered from the phase detector amplifier  $Q_{301}$ , 2SK19GR. The varactor diode,  $D_{306}$ , is used to shift the oscillating frequency in accordance with the band switch setting for a stable lock of the VCO. The output from the VCO,  $Q_{305}$ , is fed through a two stage buffer amplifier  $Q_{306}$ , 2SK19GR,  $Q_{307}$ , 2SC784R, to the mixers,  $Q_{405}$  in receive,  $Q_{501}$  and  $Q_{502}$  in transmit.

A portion of the output from  $Q_{306}$  is amplified through the buffer amplifier  $Q_{304}$ , 2SC372Y, and is fed to the mixer  $Q_{303}$ , 2SC372Y, where the signal from local oscillator unit is converted into a 8,000 to 8,500 kHz comparison signal.

This comparison signal is amplified by the amplifier  $Q_{302}$ ,  $\mu A703HC$  and fed to the phase detector circuit consisting of diodes,  $D_{303}$  and  $D_{304}$ , 1S-1007.

The phase detector compares the phase of the comparison signal with that of the reference signal which is fed through pin 17 from the FIX unit (VFO or FIX crystal signal), and any phase difference is converted into an error correcting voltage. This error voltage is amplified by  $Q_{301}$ , 2SK19GR, and fed to the varactor diode  $D_{305}$ , 1SV50, which changes the output signal phase to track the input.

The programmable unijunction transistor  $D_{301}$ , N13T1, generates a sawtooth wave when the VCO is unlocked. The sawtooth wave is used to lock the VCO. A portion of it is fed to the inverter  $Q_{308}$ , and rectified by  $Q_{310}$  1S1555.

The rectified voltage causes  $Q_{309}$ , 2SC372Y, to conduct and its emitter voltage is used to conduct  $Q_{607}$  in the AF unit thus shorting the audio input to quiet the receiver when the PLL is unlocked.

In transmit, this voltage controls  $Q_{507}$  in the EXCITER unit causing  $Q_{506}$  cut off to disable the exciter stages. Thus, the transmitter and receiver stop functioning when the VCO is unlocked. With this voltage, a multivibrator  $Q_{308}$ , TP4011AN, produces a blanking pulse which controls the pilot lamp driver  $Q_{310}$ , MPSA13, causing the pilot lamp to flicker indicating VCO unlock.

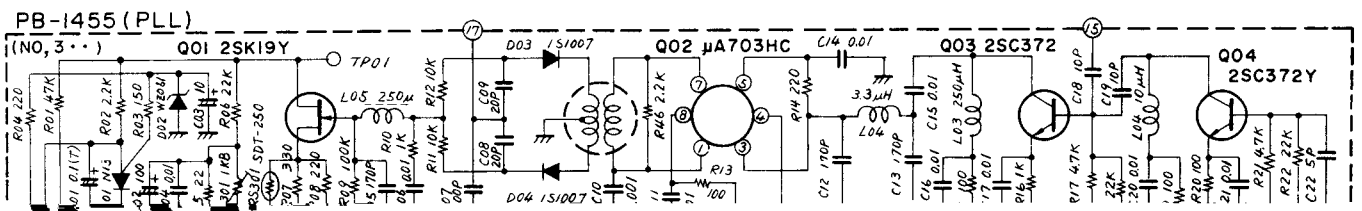



## POWER SUPPLY & REGULATOR UNIT (PB-1469)

The power supply has been designed to operate from 100/110/117/200/220 or 234 volts AC 50/60 Hz, or 12 volts DC, negative ground. Inserting the appropriate power plug into the rear panel receptacle makes the necessary connections to operate the supply in either mode, AC or DC.

For AC operation, the DC voltage is supplied from the bridge connected rectifier unit  $D_{150}$ , M4B-5, which is connected to a 20 volt, 3.5 amps secondary winding of the power transformer. The DC voltage is regulated at 13.5 volts by the voltage regulator circuit consisting of  $Q_{1501}$ , 2SD313D, and  $Q_1$ , 2SD114.

Since such circuits as the VFO, local oscillator PLL circuit, require an extremely stabilized voltage, the 13.5 volts DC voltage is further stabilized at 8 volts by the voltage regulator  $Q_{1503}$ , 2SC735Y,  $Q_{1504}$ , 2SD313D, and  $Q_{1505}$ , 2SC372Y.

For DC operation, the positive voltage is connected to pin 3 and the negative voltage to pin 4, of the power receptacle,  $J_1$ . To protect the circuits from any reverse connection of the DC voltage,  $D_1$ , DS130YD, conducts heavily in the reverse polarity connection to blow the line fuse in the DC cord. It is placed between pin 3 and ground on  $J_1$ .

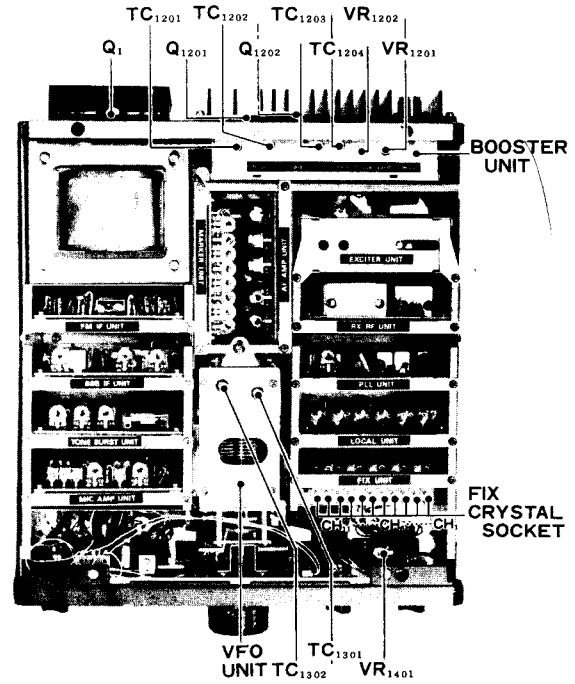

TOP VIEW

Figure 24

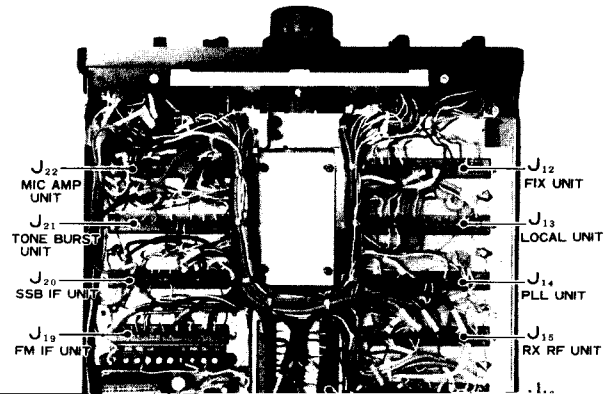
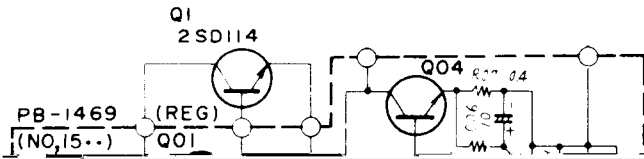

# MAINTENANCE & ALIGNMENT

## GENERAL

Your model FT-221R transceiver has been carefully aligned and tested at factory prior to shipment. The reliability of the solid-state devices used in the FT-221R should provide years of trouble free service if the transceiver is not abused and normal, routine maintenance is carried out.

The following precautions should be observed to prevent damage to the transceiver:

- (1) Do not interchange the AC and DC power cords.
- (2) Do not apply any AC voltage other than the voltage determined by the transformer wiring.
- (3) Do not exceed 14 volts DC, at the POWER receptacle, on DC operation. When operating mobile, check the battery voltage under the load (transmitter "keyed" in FM mode) with the engine running fast enough so the ammeter shows a "charge". In addition, do not operate the FT-221R if the supply voltage is below 12 volts DC.
- (4) Avoid direct exposure to sunshine or water.

## ROUTINE MAINTENANCE

Routine maintenance should be limited to keeping the transceiver clean, and periodic performance checks of the transmitter RF power output and the receiver sensitivity.

### Cleaning:

When the transceiver has been used in dusty or sandy areas, the interior should be periodically cleaned. A vacuum-cleaner, or low pressure air source should be used, while any accumulated dirt may be removed with a soft brush. Check that the interior is thoroughly dry before replacing the case and/or operating the equipment. Wipe the exterior with a damp cloth whenever required.

## PERFORMANCE CHECKS

Make all performance checks at 13.5 volts DC (under load) or AC with the appropriate voltage as determined by the transformer wiring.

Check the transmitter output as follows:

- (a) Connect a suitable 50 ohm dummy load/RF wattmeter to the ANT receptacle.
- (b) Set the MODE switch to FM and key the transmitter while observing the power output. The power should be approximately 10 watts, and the S-meter should read between 6 and 8.
- (c) Set the MODE switch to SSB and key the transmitter. Speak normally into the microphone. The output meter should show 3 to 5 watts mean value.

Check the receiver sensitivity as follows:

- (a) Connect an AC VTVM to the SP receptacle, set the MODE switch to FM and set the SQUELCH control fully counter-clockwise.
- (b) Connect the RF output of a precision, VHF signal generator to the ANT receptacle and with no signal input note the VTVM reading. Adjust the VOLUME control and VTVM range, as required, to obtain an approximate full scale reading. (DO NOT change the VOLUME control setting after this adjustment is made.)
- (c) Set the signal generator to the receiving frequency of the transceiver and adjust the output amplitude of the signal generator until the VTVM reads 1/10th (20 dB decrease) of the reading in step (b). The signal generator output voltage at this point is the 20 dB quieting sensitivity, and should be approximately 0.3 $\mu$ V.
- (d) Set the MODE switch to SSB position and connect the AC VTVM to the speaker output. Apply an unmodulated, 0.5 $\mu$ V signal, from the standard signal generator and tune the transceiver for a maximum VTVM reading.
- (e) Set the RF GAIN control to the fully clockwise position and adjust the AF GAIN control for a 450 mV VTVM reading.
- (f) Reduce the signal generator output and read the VTVM reading. The VTVM reading should be less than 45 mV for a 10 dB S/N ratio.

If the above performance checks indicate a need for realignment it is recommended that the transceiver be returned to the dealer for alignment. The alignment procedures require special test equipment and techniques not normally available to the average owner. Attempts to realign the tuned

circuits without proper test equipment will result in degraded performance of the transceiver.

## ALIGNMENT

SOME OF THE FOLLOWING ALIGNMENT PROCEDURES REQUIRE SPECIAL TEST EQUIPMENT AND TECHNIQUES AND SHOULD ONLY BE DONE BY AN EXPERT TECHNICIAN.

### AF AMP UNIT

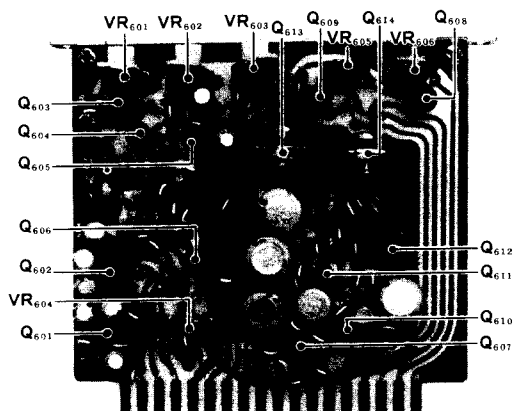

Figure 26

#### (1) CW Break-In

Adjust VR<sub>601</sub>, DELAY control, for a suitable release time.

#### (2) CW Sidetone Level

control, VR<sub>603</sub>, to the minimum point that will prevent the speaker output from tripping the VOX. Adjust the DELAY control, VR<sub>601</sub>, for a suitable relay release time.

#### (4) Discriminator Meter Center

Set the controls as follows:

CHANNEL . . . VFO

MODE . . . . . FM

DISC . . . . . OFF (down position)

RF GAIN . . . Fully CW

MARKER . . . ON (up position)

Tune the transceiver for maximum S-meter reading at a marker signal. This maximum reading has a 3 kHz width and the VFO should be set to the center of the signal. Turn the DISC switch on and adjust the center potentiometer, VR<sub>605</sub>, until the meter indicates mid point on the scale. Check that the meter moves equally toward both ends when the VFO frequency is shifted equally up or down. Shift the VFO frequency 10 kHz lower than the zero center meter indication, and adjust the DISC potentiometer, VR<sub>606</sub>, until the meter indicates 2.

### MARKER UNIT

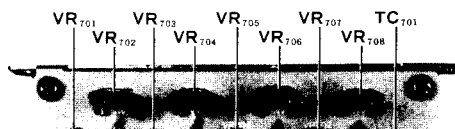

When the counter is not available, use another H.F. receiver and calibrate the 100kHz signal against WWV or JJY.

**(2) Voltage Adjustment for the Varicap Tuning Circuit**

Measure the voltage at pins 3, 4, 5, 6, 7, 8, 9 and 10 with a VTVM connected between the pins and ground.

Adjust the appropriate potentiometer, VR<sub>701</sub> to VR<sub>708</sub>, for following pin voltages:

Pin No.	3	4	5	6	7	8	9	10
Adjust. VR No.	701	702	703	704	705	706	707	708
Volt. DC. V.	2.0	2.5	3.0	3.5	4.0	4.5	5.0	5.5

Table 3

**(2) Carrier Balance (SSB Receive)**

Disconnect the antenna.

Set the MODE switch to either the LSB or USB modes, and the RF GAIN control fully counter clockwise. Adjust VR<sub>901</sub> and TC<sub>901</sub> (CARRIER BALANCE) alternately until the S-meter indicates full scale. Change the MODE switch to CW position and check if the S-meter indicates exactly full scale.

**MIC AMP UNIT**

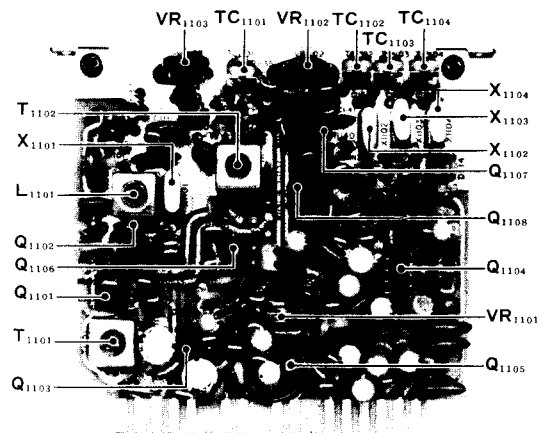
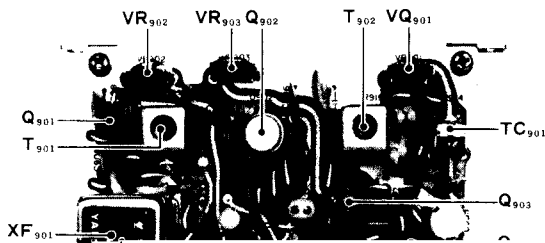

Figure 29

**SSB IF UNIT**



**(1) SSB Carrier Frequency**

Connect a dummy load, such as the YAESU YP-

### (3) Carrier Balance (SSB Transmit)

Connect a dummy load to the antenna receptacle.

dial. Set the BAND switch to 144.5 MHz and adjust TC<sub>202</sub> to zero beat, then adjust TC<sub>203</sub> for

conductor of coax cable at the antenna receptacle. Set the MODE switch to the LSB mode. Set the MIC GAIN control to the fully CCW position. Set the VOX switch to MOX position. Adjust VR<sub>1102</sub> and TC<sub>1101</sub> (CARRIER BALANCE) alternately to minimize the VTVM reading.

Repeat this procedure until a minimum reading is obtained equally for both side bands.

146.0 MHz, TC<sub>206</sub> for 146.5 MHz, TC<sub>207</sub> for 147.0 MHz and TC<sub>208</sub> for 147.5 MHz for a zero beat against the marker signal.

For the U.S. model, set the RPT switch to REV, the AUX/600 kHz switch to 600 kHz and the BAND switch to 146.5. Adjust TC<sub>210</sub> for zero beat. Change the BAND switch to 147.0 and adjust TC<sub>211</sub> for zero beat. For the European model, set the BAND switch to 145.0 and adjust TC<sub>210</sub> for zero beat. During the above repeater frequency

PLL UNIT

EXCITER UNIT/BOOSTER UNIT

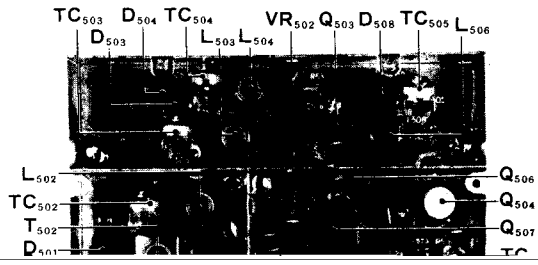
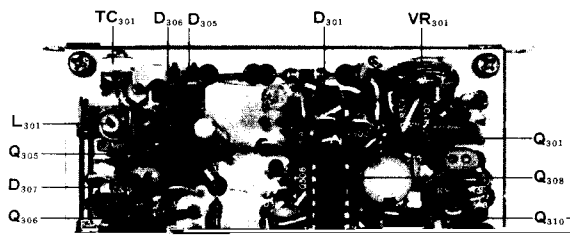

## TONE BURST UNIT

### (2) PO Meter Set

The PO (Power Output) meter indicates relative power output. After the completion of the above power output alignment, set the meter control, VR<sub>1202</sub>, to the point where the meter indicates 80% of full scale.

### (3) AM Carrier Level

Set the MODE switch to the AM position. Adjust VR<sub>502</sub>, in the EXCITER UNIT, for 2.5 watts unmodulated carrier output on the dummy load.

### (4) ALC Threshold

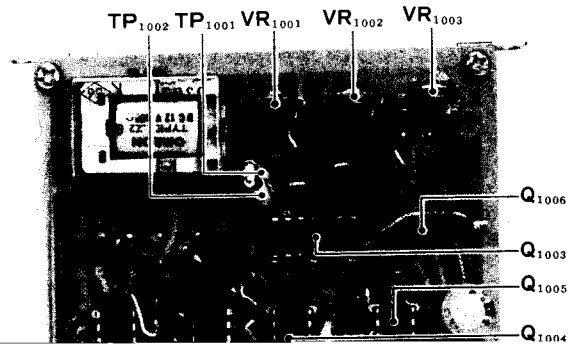

Set the VOX GAIN control to the PTT position and remove the unit from its socket. Reconnect the disconnected test points and reinstall it into its socket.

The burst signal is automatically transmitted when the PTT switch on the microphone is keyed twice as, i.e., key 0.5 second, receive 0.5 second and then transmit. The deviation of the burst signal is preset at the factory to approximately 0.5 second. It may be adjusted with VR<sub>1001</sub>. A clockwise rotation produces a longer deviation.

## REGULATOR UNIT

Use an AC supply for this alignment. Connect a VTVM DC probe to the 13.5 volt line of the power supply unit. Adjust VR<sub>150</sub> for a 13.5 volt VTVM reading. Connect the VTVM to the 8 volt line and adjust VR<sub>1502</sub> for a 8 volt VTVM reading.

## FM IF UNIT

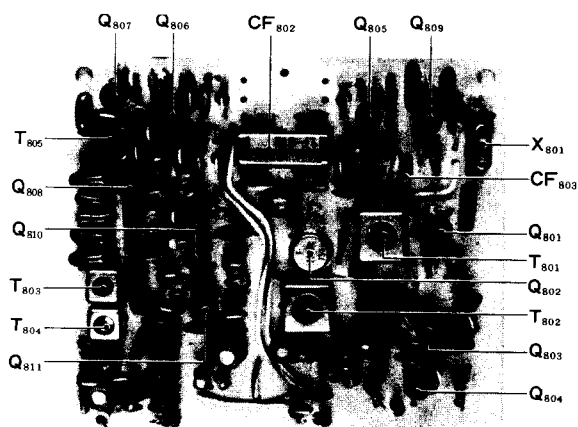

Figure 39

## CONNECTOR RESISTANCE CHART

UNIT PIN	FIX	LOCAL	PLL	RX RF	EXCITER	AF AMP	MARKER	FM IF	SSB IF	TONE BURST	MIC AMP
	J <sub>12</sub>	J <sub>13</sub>	J <sub>14</sub>	J <sub>15</sub>	J <sub>16</sub>	J <sub>17</sub>	J <sub>18</sub>	J <sub>19</sub>	J <sub>20</sub>	J <sub>21</sub>	J <sub>22</sub>
1	E	E	E	E	E	E	E	E	E	E	E
2	∞	E	O	2.6 K	250	0	53*	5.5 K	E	1.7 K	E
3	∞	O	2.3 K	—	250	53*	2.4 K	E	3.5 K	—	6K
4	∞	—	53*	E	O	74*	2.5 K	500	—	450	3.2K
5	∞	E	E	O	6K	—	2.5 K	10	700	53	300
6	∞	E	45*	∞	E	∞	3 K	1 K	—	53	E
7	∞	53	160*	O	E	0	3 K	300	250	∞	E
8	∞	—	E	E	2.4 K	0	3 K	1.6K	—	2.4 K	O
9	E	E	2K	0	2K	40*	2.7 K	E	53*	2.4 K	12K
10	E	E	160*	E	2.6K	E	2.3 K	2.5K	—	∞	700
11	∞	—	—	53*	2.6K	—	E	E	E	350	E
12	53*	—	53*	E	100K	1.6K	∞	—	—	—	E
13	∞	—	E	2.4 K	1.1 K	850	E	53*	700K	—	E
14	∞	—	E	3.5 K	E	1 K	—	3.3 K	—	850	700K
15	∞	—	O	3.3 K	E	2.1 K	—	100 K	250	—	250
16	∞	—	—	E	E	1.5 K	2.4 K	E	500	—	250
17	∞	—	∞	0	∞	5.5K	E	0	2.6 K	—	E
18	E	—	E	E	E	E	E	E	46*	E	E
19		—							—		E



# VOLTAGE CHART

## FIX Unit

	E	B	C		E	B	C
Q101	0.9	1.4	7.7	Q102	2.2	2.9	5.8

## LOCAL Unit

	E	B	C		E	B	C		E	B	C
Q201	2.4	2.5	7.6	Q202	1.1	1.3	7.9	Q203	0.9	1.4	7.6

## PLL Unit

	E(S)	B(G)	C(D)		E(S)	B(G)	C(D)		E(S)	B(G)	C(D)
Q301	1.6	0	4.5	Q305	0.9	0	5.4	Q309	0	0	8.0
Q303	0.9	1.4	8.0	Q306	1.0	0	5.9	Q310	0	0.7	1.3
Q304	0.5	1.1	7.5	Q307	0.5	0.8	7.2				

	1	2	3	4	5	6	7	8	9	10	11	12	13	14
Q302	7.2	-	1.5	E	1.5	-	7.2	7.5						
Q308	4.9	4.9	0.2	8.0	0	1.9	E	8.0	8.0	0	8.0	0	0	8.0

## RX RF Unit

	E (S)		B (G)		C (D)		G <sub>2</sub>			E (S)		B (G)		C (D)	
	R	T	R	T	R	T	R	T		R	T	R	T	R	T
Q401	1.5	0	1.6	0	8.0	0.1	3.9	0	Q404	0.7	0	1.4	0	7.9	0.1
Q402	1.6	1.1	0	0	7.9	0.1			Q405	1.0	0	0	0	7.7	0
Q403	1.2	0	1.8	0	7.8	0.1									

## EXCITER Unit (on Transmit)

	LSB.USB.CW			AM.FM				LSB.USB.CW			AM.FM				LSB.USB.CW			AM.FM		
	E(S)	B(G)	C(D)	E(S)	B(G)	C(D)		E(S)	B(G)	C(D)	E(S)	B(G)	C(D)		E(S)	B(G)	C(D)	E(S)	B(G)	C(D)
Q501	1.3	0	12.1	1.4	0	11.8	Q504	0.4	1.2	10.1	0.4	1.2	10.0	Q507	0	0	13.3	0	0	13.3
Q502	1.3	0	12.1	1.4	0	11.7	Q505	0	0.7	13.4	0	0.7	13.4	Q508	1.1	1.8	5.4	1.1	1.8	5.4
Q503	1.2	1.9	12.0	1.2	1.9	11.9	Q506	12.5	13.3	13.5	12.5	13.3	13.5	Q509	4.9	5.5	13.5	4.9	5.5	13.5

Receive.....0V

## AF AMP Unit

	LSB.USB.CW AM			FM				LSB.USB.CW AM			FM				LSB.USB.CW AM			FM		
	E(S)	B(G)	C(D)	E(S)	B(G)	C(D)		E(S)	B(G)	C(D)	E(S)	B(G)	C(D)		E(S)	B(G)	C(D)	E(S)	B(G)	C(D)
Q601	0.4	1.0	7.0	0.4	1.0	7.0	Q607	0	0	0.6	0	0	0.6	Q612	13.5	12.9	7.5	13.5	12.9	7.5
Q603	0.4	0	0.6	0.4	0	0.6	Q608	0	0	0	1.9 <sup>★</sup>	0	5.7 <sup>★</sup>	Q613	6.8	7.4	13.5	6.8	7.4	13.5
Q604	0	0.6	12.9	0	0.6	12.9	Q609	0	0	0	2.6 <sup>★</sup>	0	6.3 <sup>★</sup>	Q614	6.8	6.2	0	6.8	6.2	0
Q605	0.4	1.0	5.8	0.4	1.0	5.8	Q610	0	0.6	3.8	0	0.6	3.8							
Q606	2.9	1.0	8.0	2.9	1.0	8.0	Q611	8.5	9.1	12.9	8.5	9.1	12.9							

★FM Transmit.....0V

	1	2	3	4	5	6	7	8	9
Q602	4.7	2.8	2.2	2.1	0	0.5	0.7	1.1	8.0

## MARKER Unit (Marker Switch.....ON)

	E	B	C		E	B	C		E	B	C
Q701	1.8	2.4	8.0	Q702	2.1	3.7	7.7	Q704	E	0.6	0.9

	1	2	3	4	5	6	7	8	9	10	11	12	13	14
Q703	1.8	E	3.8	4.0	4.0	4.0	E	0	4.0	0	3.7	3.0	0	0.8

## FM Unit

	LSB.USB.CW AM			FM				LSB.USB.CW AM			FM				LSB.USB.CW AM			FM		
	E(S)	B(G)	C(D)	E(S)	B(G)	C(D)		E(S)	B(G)	C(D)	E(S)	B(G)	C(D)		E(S)	B(G)	C(D)	E(S)	B(G)	C(D)
Q801	1.8	2.5	7.7	1.8	2.5	7.7	Q805	0	0	0	1.3 <sup>★</sup>	0.7 <sup>★</sup>	7.2 <sup>★</sup>	Q809	0	0	0	0.6 <sup>★</sup>	1.3 <sup>★</sup>	7.0 <sup>★</sup>
Q803	0	1.9	5.1	0	1.9	5.1	Q806	0	0	0	1.4 <sup>★</sup>	2.1 <sup>★</sup>	2.5 <sup>★</sup>							
Q804	5.8	5.8	5.3	5.8	5.8	5.3	Q807	0	0	0	0.7 <sup>★</sup>	1.4 <sup>★</sup>	7.0 <sup>★</sup>							

★FM Transmit.....0V

		1	2	3	4	5	6	7	8
Q802	T·R	7.0	—	1.5	0	1.5	—	7.0	7.5
Q808	FM·R	1.8	1.8	6.8	0	5.5	1.8	1.8	
	T·R	0	0	0	0	0	0	0	

## SSB IF Unit

	E(S)		B(G)		C(D)			E(S)		B(G)		C(D)			E(S)		B(G)		C(D)	
	R	T	R	T	R	T		R	T	R	T	R	T		R	T	R	T	R	T
Q901	0.7	0	0.7	0	7.3	0	Q905	0	0	0.7	0	7.2	0	Q908	0.3	0.3	1.0	1.0	5.8	5.8
Q903	1.1	0	0	0	7.8	0	Q906	0	0.6	0	0	0	7.0							
Q904	0.7	0	0.7	0	7.3	0	Q907	5.3	5.3	5.9	5.9	6.8	6.8							

		1	2	3	4	5	6	7	8
Q902	R	0	1.2	0	1.8	5.5	7.6	7.3	0
	T	0	0	0	0	0	0	0	0

## TONE BURST Unit

		1	2	3	4	5	6	7	8	9	10	11	12	13	14	15	16
		Q1001	R	0	0	8.0	0	8.0	8.0	0	0	0	8.0	0	8.0	7.2	8.0
	T	8.0	8.0	0	8.0	0	0	0	0	0	8.0	0	8.0	7.2	8.0		
Q1002	R · T	7.2	8.0	0	8.0	0	0	0	0	8.0	8.0	8.0	0	0	8.0		
Q1003	R · T	0	0	8.0	0	8.0	7.3	0	8.0	8.0	0	8.0	7.2	0	8.0		
Q1004	R	8.0	0	7.2	0	7.3	0	8.0	0	0	8.0	8.0	0	0	7.2	0	8.0
	T	8.0	0	7.2	0	7.3	0	8.0	0	8.0	0	8.0	0	0	7.3	0	8.0
Q1005	R · T	0	8.0	0	0	8.0	8.0	0	0	0	0	0	0	0	8.0	0	8.0

	S	G	D
Q1006	0.9	0	8.0

## BOOSTER Unit (on Transmit)

	LSB.USB.CW			AM			FM				LSB.USB.CW			AM			FM		
	E(S)	B(G)	C(D)	E(S)	B(G)	C(D)	E(S)	B(G)	C(D)		E(S)	B(G)	C(D)	E(S)	B(G)	C(D)	E(S)	B(G)	C(D)
Q1201	0	0.7	12.3	0	0.6	3.6	0	0.6	11.7	Q1202	0	0.7	13.5	0	0.4	13.3	0	0.2	13.1

Receive.....0V

## VFO Unit

	E(S)	B(G)	C(D)		E(S)	B(G)	C(D)		E(S)	B(G)	C(D)
Q1301	2.1	2.7	4.4	Q1302	1.6	0	7.6	Q1303	1.6	2.1	6.9

## MIC AMP Unit

	LSB. USB						CW						AM						FM					
	E(S)		B(G)		C(D)		E(S)		B(G)		C(D)		E(S)		B(G)		C(D)		E(S)		B(G)		C(D)	
	R	T	R	T	R	T	R	T	R	T	R	T	R	T	R	T	R	T	R	T	R	T	R	T
Q1101	0	0	0	0	0	0	0	4.9	0	2.6	0	8.0	0	1.9	0	2.6	0	7.8	0	2.2	0	2.6	0	7.8
Q1102	0	0	0	0	0	0	0	0	0	0	0	0	0	0	0	0	0	0	0	1.6	0	2.2	0	7.2
Q1103	1.5	1.5	2.1	2.1	3.9	3.9	1.5	1.5	2.1	2.1	3.9	3.9	1.5	1.5	2.1	2.1	3.9	3.9	1.5	1.5	2.1	2.1	3.9	3.9
Q1105	0	2.2	0	0	0	7.8	0	0	0	0	0	0	0	0	0	0	0	0	0	0	0	0	0	0
Q1106	0	0.7	0	0	0	7.3	0	0	0	0	0	0	0	0	0	0	0	0	0	0	0	0	0	0
Q1107	3.0	3.0	3.4	3.4	6.8	6.8	3.0	4.9	3.4	3.4	6.8	8.0	2.7	3.0	3.4	3.4	6.8	6.7	2.7	2.7	3.4	3.4	6.8	6.8
Q1108	2.5	2.5	1.9	1.9	6.8	6.8	2.5	2.5	2.1	2.3	6.8	6.8	2.3	2.5	1.4	1.8	6.9	6.8	2.3	2.3	1.3	1.4	6.9	6.9

		1	2	3	4	5	6	7	8	9
	Q1104	R	4.1	2.4	1.8	1.7	0	0	0	0.7
	T	4.1	2.4	1.8	1.7	0	0.5	3.3	1.2	6.9

## REG Unit

	E	B	C		E	B	C		E	B	C
	Q1501	14.1	14.6		22.6	Q1503	8.7		9.3	13.5	Q1505
Q1502	9.0	9.7	14.6	Q1504	8.0	13.5	8.7	Q <sub>1</sub>	13.5	14.1	22.5

## AM Mod(Q7)

	E		B		C	
	R	T	R	T	R	T
USB USB CW	0	12.3	0	12.9	0	13.5
AM	0	3.6	0	4.2	0	13.4
FM	0	11.7	0	12.3	0	13.2

# PARTS LIST

MAIN CHASSIS				6, 7	SLE-12251
<b>PB PRINTED CIRCUIT BOARD</b>				8	SLE-14201
1471 (A~Z)	LED	BOARD		9	SLE-14301
1552 (A~Z)	SWITCH	BOARD		<b>J JACK</b>	
<b>Q TRANSISTOR</b>				1	QMS-AB4M
1		2SD114		2	CS-250
7		2SD313D		3	SG-7615
<b>D DIODE</b>				4	SG-8050
1	Si Bridge	DS-130-YD		5	FM-144J
6~10	Si	10D-1		6	XG-8018
11	LED	GD-4		7~10	CN-7017J
12		RD-4		11	SO-239
13		TLR-108		12, 14~19, 21	3305-018-011
<b>R RESISTOR</b>				13, 20, 22	1150-036-009
CARBON COMPOSITION				25	CN-1463
16	1/4W	10KΩ		24	SI-3101
15	1/4W	100KΩ		<b>P PLUG</b>	
19	1/2W	10Ω		24	SI-8501
17	1/2W	56Ω		<b>F FUSE</b>	
18	1/2W	100Ω		1	2A 100V~117V
14,	1/2W	220Ω			1A 200V~234V
13, 21	1/2W	470Ω		<b>FS FUSE HOLDER</b>	
23	1/2W	5.6KΩ		1	SN-1001 #2
11	1/2W	22KΩ		<b>PL PILOT LAMP</b>	
12	1/2W	27KΩ		1~3	14V 40mA
<b>VR POTENTIOMETER</b>				<b>FIX UNIT</b>	
4	EWK-DOAS 15023	500ΩB/500ΩC		<b>PB PRINTED CIRCUIT BOARD</b>	
5	VM13A-5M3121	5KA		1453 (A~Z) FIX OSC CIRCUIT	
8	EVH-BOAS-15A53	5KA		1500 (A~Z) CRYSTAL BOARD	
6	VM20A	5KB		<b>Q TRANSISTOR</b>	
7	VM11A5M	10KA		101, 102	2SC372Y
3	EVH-BOAS-15B54	50KB		<b>D DIODE</b>	
10	EVH-BOAS-15B53	5KB		101~111	Si 1S1555
9	EVL-SOAA-00B54	50KB		<b>X CRYSTAL</b>	
<b>C CAPACITOR</b>				101~111	HC-25/U (OPTION)
DIPPED MICA				<b>XS CRYSTAL SOCKET</b>	
16, 17, 18	50WV	100PF		101~111	S2-101P
22	50WV	300PF		<b>R RESISTOR</b>	
CERAMIC DISC				CARBON FILM	
14, 28~32	50WV	0.001μF		105, 108, 109	1/4W 100Ω
33, 13	50WV	0.01μF		104	1/4W 220Ω
11~12, 15, 19~21, 23, 27	50WV	0.047μF		101	1/4W 1.5KΩ
24~26	500WV	0.01μF		102, 107	1/4W 5.6KΩ
1, 2	1.4KV	0.0047μF		106	1/4W 8.2KΩ
<b>ELECTROLYTIC</b>				103	1/4W 22KΩ
10	16WV	2200μF		<b>C CAPACITOR</b>	
<b>PT POWER TRANSFORMER</b>				DIPPED MICA	
1	52-36			130	50WV 15PF
<b>CH CHOKE COIL</b>				131	50WV 20PF
1	SN-8S-500			117~127	50WV 30PF
<b>M METER</b>				129	50WV 100PF
1	SP-38A			128, 132	50WV 200PF
<b>SP SPEAKER</b>				CERAMIC DISC	
1	SA-70H			101~116	50WV 0.01μF
<b>RL RELAY</b>				<b>TC TRIMMER CAPACITOR</b>	
1	AE-3171			101~111	ECV-1ZW 20×40 20PF
<b>RLS RELAY SOCKET</b>				<b>L INDUCTOR</b>	
1	AE-3860				
<b>S SWITCH</b>					
1	ESR E22CR15D				
2	ESR 448R15A				
3	ESR 485R15A				
4	SP 2022				
5	SLE-12301				

101~111	EL0610-102K	1mH	PLL UNIT	
112	EL0610-251K	250 $\mu$ H	PB	PRINTED CIRCUIT BOARD
113	FL-3H 1R2M	1.2 $\mu$ H	1455 (A~Z)	PLL CIRCUIT
			Q	IC FET & TRANSISTOR
LOCAL UNIT			302	IC $\mu$ A703HC
PB	PRINTED CIRCUIT BOARD		308	TP4011AN
1454 (A~Z)	LOCAL OSC CIRCUIT		301	FET 2SK10V

05.306

REVISED

TC	TRIMMER CAPACITOR		404, 414, 417	50WV	0.001 $\mu$ F
301	ECV-1ZW 10 $\times$ 40	10PF	405 ~ 407, 412, 413,	50WV	0.01 $\mu$ F
302, 303	ECV-1ZW 10 $\times$ 51	10PF	418 ~ 420, 424, 425, 427, 428,		
			415, 416	50WV	0.047 $\mu$ F
L	INDUCTOR		ELECTROLYTIC		
302	FL-3H-3R3M	3.3 $\mu$ H	423	16WV	1 $\mu$ F
304, 306	RFC	10 $\mu$ H	TC	TRIMMER CAPACITOR	
303, 305	RFC	250 $\mu$ H	401 ~ 404	ECV-1ZW 10 $\times$ 40	10PF
301	OSC #221013A		405	ECV-1ZW 10 $\times$ 53	10PF
T	TRANSFORMER		L	INDUCTOR	
309	#221014		401	#221003	
302, 303	R-12 4102		402	#221004	
			403	#221005	
			404	#22J006	

406.

EI.0610-220K.

?? $\mu$ H

197

EI.0610-220K

272 $\mu$ H

511, 512, 514, 519	50WV	5PF	634, 613	1/4 W	47KΩ
507, 508, 516, 523, 537, 538	50WV	10PF	603, 633, 637	1/4 W	100KΩ
510, 506, 535	50WV	20PF	607	1/4 W	1MΩ
528	50WV	27PF			
CERAMIC DISC			CARBON COMPOSITION		
513, 534	50WV	1PF	608, 609	1/2 W	3.3MΩ
502, 503	50WV	0.001μF	610	1/2 W	5.6MΩ
501, 504, 505, 509, 515,	50WV	0.01μF	WIRE WOUND		
517, 518, 520 ~ 522, 524, 526, 536			645, 646	1/2 W	0.22Ω
MYLAR			RS THERMISTOR		
532	50WV	0.047μF	601	SDT-250	
ELECTROLYTIC			VR POTENTIOMETER		
525, 527, 529, 531	16WV	10μF	605	EVL-SOAA-00B53	5KB
530	16WV	22μF	602, 603	EVL-VOAA-00B14	10KB
533		33μF	604	EVL-SOAA-00B14	10KB
TC TRIMMER CAPACITOR			606	EVL-SOAA-00B54	50KB
501 ~ 505	ECV-1ZW 10×40	10PF	601	EVL-VOAA-00B26	2MB
506	ECV 1ZW 20×51	20PF	C CAPACITOR		
507, 508	ECV 1ZW 20×32	20PF	DIPPED MICA		
L INDUCTOR			637	50WV	200PF
503	# 221008		635	50WV	280PF
504, 502	# 221009		628	50WV	330PF
507, 510	# 221018		CERAMIC DISC		
508, 509	# 221017		605	50WV	470PF
506	# 221036		636	50WV	0.047μF
T TRANSFORMER			MYLAR		
501	R-12 4073		610, 615	50WV	0.001μF
502	# 221035		629, 630	50WV	0.002μF
AF UNIT			608, 611, 619, 620	50WV	0.01μF
PB PRINTED CIRCUIT BOARD			616 ~ 618	50WV	0.02μF
1499 (A ~ Z) AF CIRCUIT			614, 631	50WV	0.047μF
			609	50WV	0.1μF
			ELECTROLYTIC		
Q IC FET & TRANSISTOR			601, 612, 623, 626	16WV	1μF
602	IC	LD-3001	621, 622	16WV	4.7μF
603	FET	2SK19Y	602 ~ 604, 606, 607, 613	16WV	10μF
608, 609	"	2SK19GR	624	10WV	100μF
612		2SA695	625, 633	16WV	100μF
614		2SB529	627, 632	16WV	220μF
601, 605, 606, 607, 610		2SC372Y	MARKER UNIT		
611		2SC711	PB PRINTED CIRCUIT BOARD		
604		2SC735Y	1499 (A ~ Z) MARKER CIRCUIT		
613		2SD359			
D DIODE			Q IC & TRANSISTOR		
601 ~ 604	Si	1S1555	703	IC	34024PC
605	Varistor	MV-5W	701, 702, 704	Tr	2SC372Y
R RESISTOR			X CRYSTAL		
CARBON FILM			701	HC-18/U	12.8MHz
642	1/4 W	10Ω	R RESISTOR		
641	1/4 W	22Ω	CARBON FILM		
628	1/4 W	100Ω	701 ~ 708	1/4 W	100Ω
647	1/4 W	180Ω	711, 713	1/4 W	1KΩ
622, 629, 644	1/4 W	220Ω	716	1/4 W	2.2KΩ
626	1/4 W	470Ω	710	1/4 W	10KΩ
611	1/4 W	680Ω	709, 715	1/4 W	22KΩ
601, 616, 638, 639	1/4 W	1KΩ	714	1/4 W	100KΩ
604, 635, 636	1/4 W	1.5KΩ	712	1/4 W	220KΩ
623, 624, 625, 631	1/4 W	2.2KΩ	VR POTENTIOMETER		
605, 614, 643	1/4 W	3.3KΩ	701 ~ 708	EVL-SOAA-00B14	10KB
606, 612, 618, 619, 620, 627	1/4 W	4.7KΩ	C CAPACITOR		
617	1/4 W	5.6KΩ	DIPPED MICA		
630, 632	1/4 W	6.8KΩ	709	50WV	3PF
602	1/4 W	15KΩ	701, 707	50WV	27PF
615	1/4 W	22KΩ	702, 703	50WV	220PF
621	1/4 W	33KΩ			
640	1/4 W	39KΩ			

CERAMIC DISC			810, 830, 831, 837, 838, 841	50WV	0.01 $\mu$ F
704 ~ 706, 708	50WV	0.01 $\mu$ F	828, 829	50WV	0.02 $\mu$ F
ELECTROLYTIC			811, 817, 818, 820 ~ 825	50WV	0.047 $\mu$ F
ELECTROLYTIC			STYROL		
710	16WV	10 $\mu$ F	826	50WV	330PF
ELECTROLYTIC			827	50WV	1000PF
TC	TRIMMER CAPACITOR		TANTALUM		
701	ECV-1ZW	20 $\times$ 40	20PF	839, 840	25WV
ELECTROLYTIC			1 $\mu$ F		
L	INDUCTOR		849, 850	16WV	1 $\mu$ F
702	RFC	22 $\mu$ H	832, 842	16WV	4.7 $\mu$ F
701	RFC	250 $\mu$ H			
FM IF UNIT			L INDUCTOR		
PB	PRINTED CIRCUIT BOARD		804	EL0610-251K	250 $\mu$ H
1463 (A ~ Z)	FM IF CIRCUIT		801 ~ 803, 806, 807	EL0610-102K	1mH
			805	EL0610-202K	2mH
Q	IC FET & TRANSISTOR		T TRANSFORMER		
802	IC	$\mu$ A703HC	801, 802	R-12	4074
808	"	TA7061AP	803	4861D	
803	FET	2SK19GR	804	4861E	
801, 804 ~ 807, 809 ~ 811	2SC372Y		805	3004	
D DIODE					
801, 802, 807 ~ 810	Si	1S1555			
803 ~ 806	Ge	1S188FM			
			SSB IF UNIT		
			PB PRINTED CIRCUIT BOARD		
X	CRYSTAL		1462 (A ~ Z) SSB IF CIRCUIT		
801	HC-18/U	10.245MHz			
			Q IC FET & TRANSISTOR		
CF	CERAMIC FILTER		902	IC	TA7045M
802	CFM	455F	903, 906	FET	2SK19GR
803	10.7MF-BR		904, 905	2SC373	
			901	2SC784R	
			907, 908	2SC1000GR	
R	RESISTOR		D DIODE		
CARBON			901 ~ 903, 912, 913	Si	1S1555
804, 805, 826	$\frac{1}{4}$ W	100 $\Omega$	910	Ge	1S188FM
825, 827, 837	$\frac{1}{4}$ W	220 $\Omega$	904 ~ 907, 909	G.B	1S1007
824	$\frac{1}{4}$ W	470 $\Omega$	911	Zener	WZ110
803, 833, 842	$\frac{1}{4}$ W	560 $\Omega$	XF CRYSTAL FILTER		
808, 816, 819, 828, 829,	$\frac{1}{4}$ W	1K $\Omega$	901	XF-10A	
836, 846, 847			R RESISTOR		
809	$\frac{1}{4}$ W	1.5K $\Omega$	CARBON FILM		
839, 840	$\frac{1}{4}$ W	2.2K $\Omega$	909, 912, 914, 915, 919,	$\frac{1}{4}$ W	100 $\Omega$
811, 813, 814, 821, 843,	$\frac{1}{4}$ W	3.3K $\Omega$	932, 933, 939, 940		
849 ~ 856			926, 928	$\frac{1}{4}$ W	270 $\Omega$
801, 830, 831, 835, 844	$\frac{1}{4}$ W	4.7K $\Omega$	917, 944	$\frac{1}{4}$ W	470 $\Omega$
822, 838	$\frac{1}{4}$ W	5.6K $\Omega$	901, 902, 927	$\frac{1}{4}$ W	560 $\Omega$
802	$\frac{1}{4}$ W	10K $\Omega$	934, 938, 946, 947, 905	$\frac{1}{4}$ W	1K $\Omega$
815, 845	$\frac{1}{4}$ W	15K $\Omega$	911, 913, 921		
823, 834, 841	$\frac{1}{4}$ W	22K $\Omega$	922	$\frac{1}{4}$ W	1.5K $\Omega$
820, 832	$\frac{1}{4}$ W	47K $\Omega$			
848	$\frac{1}{4}$ W	56K $\Omega$			
806, 807, 810	$\frac{1}{4}$ W	100K $\Omega$			

<b>VR</b>	<b>POTENTIOMETER</b>		1012	16WV	1 $\mu$ F
901	EVL-SOAA-00B52	500B	1013	16WV	4.7 $\mu$ F
903	EVL-SOAA-00B13	1KB	1011	16WV	100 $\mu$ F
902	EVL-SOAA-00B53	5KB			
<b>C</b>	<b>CAPACITOR</b>		<b>RL</b>	<b>RELAY</b>	
	DIPPED_MICA		1001	LZ-2G	

MYLAR	1203, 1207, 1209	16WV	10 $\mu$ F
1111, 1115, 1116, 1122, 1132 50WV 0.047 $\mu$ F			
ELECTROLYTIC	<b>TC TRIMMER CAPACITOR</b>		
1114, 1117, 1129, 1131 16WV 1 $\mu$ F	1201	ECV-1ZW 50 $\times$ 40	50PF
1118, 1119, 1121, 1123~1125, 16WV 10 $\mu$ F	1202~1204	TSN-P-100DS	20PF
1130			
1120 16WV 22 $\mu$ F	<b>L INDUCTOR</b>		
1112, 1113 16WV 47 $\mu$ F	1201, 1207	# 221019	
	1204, 1206, 1208, 1209	# 221020	
<b>TC TRIMMER CAPACITOR</b>	1211, 1212	# 221021	
1102~1104 ECV-1ZW 20 $\times$ 40 20PF	1202, 1203	# 221022	
1101 ECV-1ZW 50 $\times$ 40 50PF	1205	# 221037	
	1210	EL0610-220K	22 $\mu$ H
<b>L INDUCTOR</b>			
1101 # 221024	<b>RL RELAY</b>		
1107 EL0610-100K 10 $\mu$ H	1201	LZ-2G DC12	450 $\Omega$
1106, 1108~1112 EL0610-102K 1mH			
	<b>VFO UNIT</b>		
<b>T TRANSFORMER</b>	<b>PB PRINTED CIRCUIT BOARD</b>		
1101 R-12 # 4074	1465 (A~Z)	VFO CIRCUIT	
1102 R-12 # 4073			
	<b>Q FET &amp; TRANSISTOR</b>		
<b>BOOSTER UNIT</b>	1302	FET 2SK19GR	
<b>PB PRINTED CIRCUIT BOARD</b>	1301, 1303	2SC372Y	
1470 (A~Z) BOOSTER CIRCUIT			
	<b>R RESISTOR</b>		
<b>Q TRANSISTOR</b>	CARBON FILM		
1201 2N5590	1307, 1311, 1312	$\frac{1}{4}$ W	100 $\Omega$
1202 2N5591	1310	$\frac{1}{4}$ W	150 $\Omega$
	1306	$\frac{1}{4}$ W	470 $\Omega$
<b>D DIODE</b>	1304	$\frac{1}{4}$ W	2.2K $\Omega$
1201, 1202 Si 10D-1	1301	$\frac{1}{4}$ W	3.3K $\Omega$
1203, 1205~1208 1S1555	1308	$\frac{1}{4}$ W	6.8K $\Omega$
1204 Ge 1S188FM	1309	$\frac{1}{4}$ W	15K $\Omega$
1209 Zener 1N4740	1302	$\frac{1}{4}$ W	18K $\Omega$
	1303	$\frac{1}{4}$ W	33K $\Omega$
<b>R RESISTOR</b>	1305	$\frac{1}{4}$ W	100K $\Omega$
CARBON COMPOSITION			
1204 $\frac{1}{2}$ W 10 $\Omega$	<b>C CAPACITOR</b>		
1201 $\frac{1}{2}$ W 22 $\Omega$	DIPPED MICA		
1203 $\frac{1}{2}$ W 56 $\Omega$	1318	50WV	2PF
1205 $\frac{1}{2}$ W 100 $\Omega$	1302	50WV	20PF
1202 $\frac{1}{2}$ W 330 $\Omega$	1313	50WV	39PF
1206 $\frac{1}{2}$ W 100K $\Omega$	1306	50WV	51PF
1207 $\frac{1}{2}$ W 1M $\Omega$	1311	50WV	68PF
	1307	50WV	270PF
<b>VR POTENTIOMETER</b>	1310	50WV	470PF
1201 EVL-SOAA-00B14 10KB	CERAMIC DISC		
1202 EVL-SOAA-00B54 50KB	1308, 1309, 1312,	50WV	0.01 $\mu$ F
	1314~1316		
<b>C CAPACITOR</b>	CERAMIC TC		
DIPPED MICA			
1216 50WV 2PF	1303	500WV	5PF UJ
1217, 1223 50WV 5PF	1304	500WV	10PF UJ
1201 50WV 10PF	1301	500WV	20PF UJ
1224 50WV 12PF	1305	500WV	82PF NPO
1213~1215 50WV 20PF	CERAMIC FEED THRU		
1205 50WV 33PF	1317	ECK-L1H102PE	1000PF
1212 50WV 39PF	<b>VC VARIABLE CAPACITOR</b>		
1211 50WV 68PF	1301	C521	
1206 50WV 100PF			
	<b>TC TRIMMER CAPACITOR</b>		
CERAMIC DISC			
1202, 1204, 1208, 1210 50WV 0.001 $\mu$ F	1301	MC10P $\times$ 2	
1218~1220 50WV 0.01 $\mu$ F	1302	KC-30P	
MYLAR	<b>L INDUCTOR</b>		
1221 50WV 0.001 $\mu$ F	1301	# 221025A	
TANTALUM	1302	EL0610-680K	68 $\mu$ H
1222 35WV 0.1 $\mu$ F	1303	EL0610-251K	250 $\mu$ H
ELECTROLYTIC			

	VR	POTENTIOMETER	
	1501, 1502	SR-19R	470ΩB
	C	CAPACITOR	
		CERAMIC DISC	
REG UNIT	1504	50WV	0.001μF

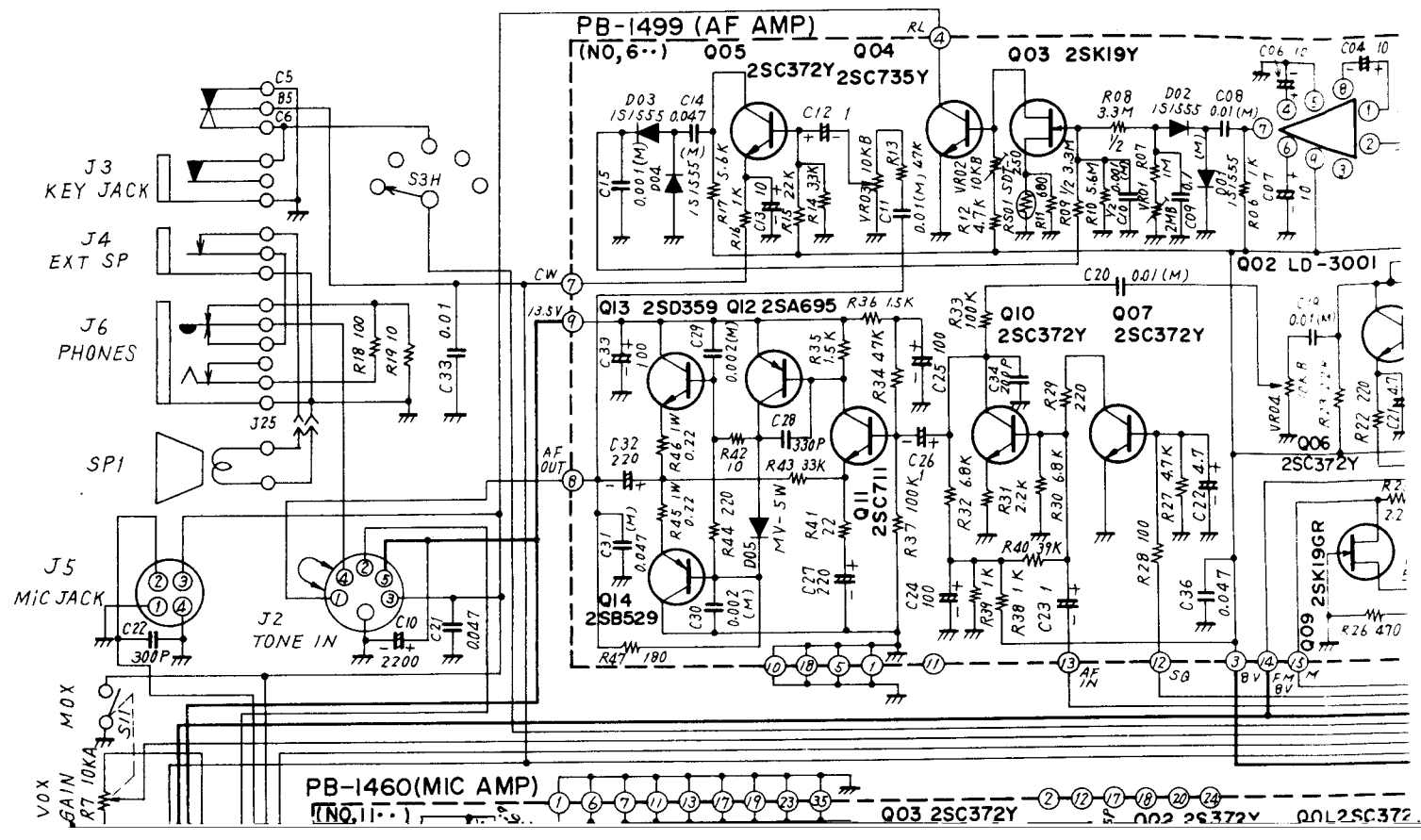

PB-1463(FM IF)

(NO, 8 ..)

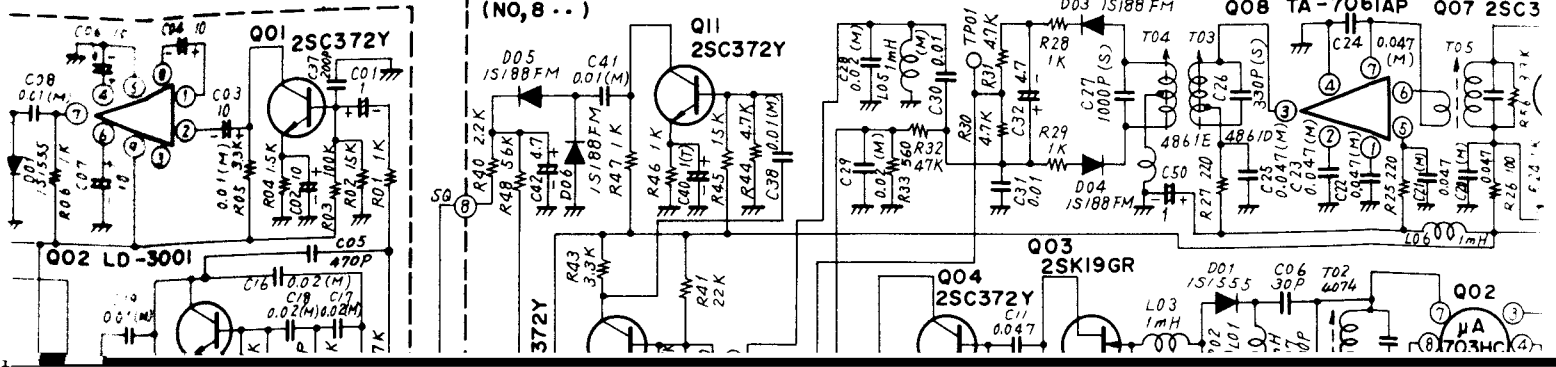

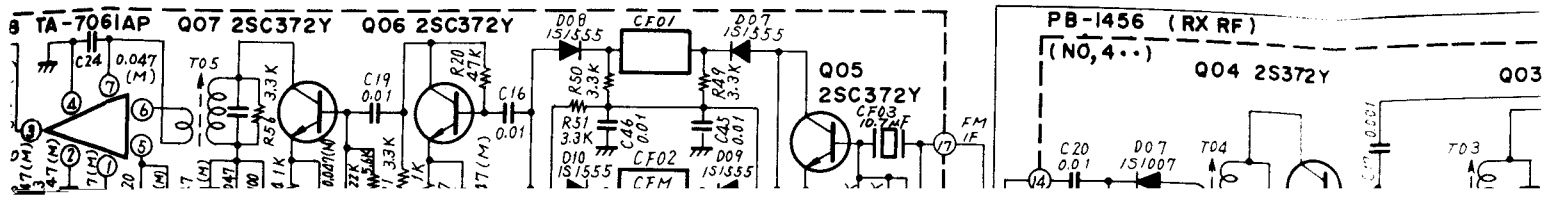



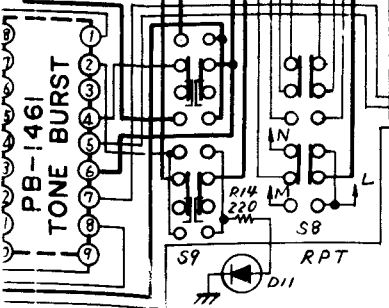
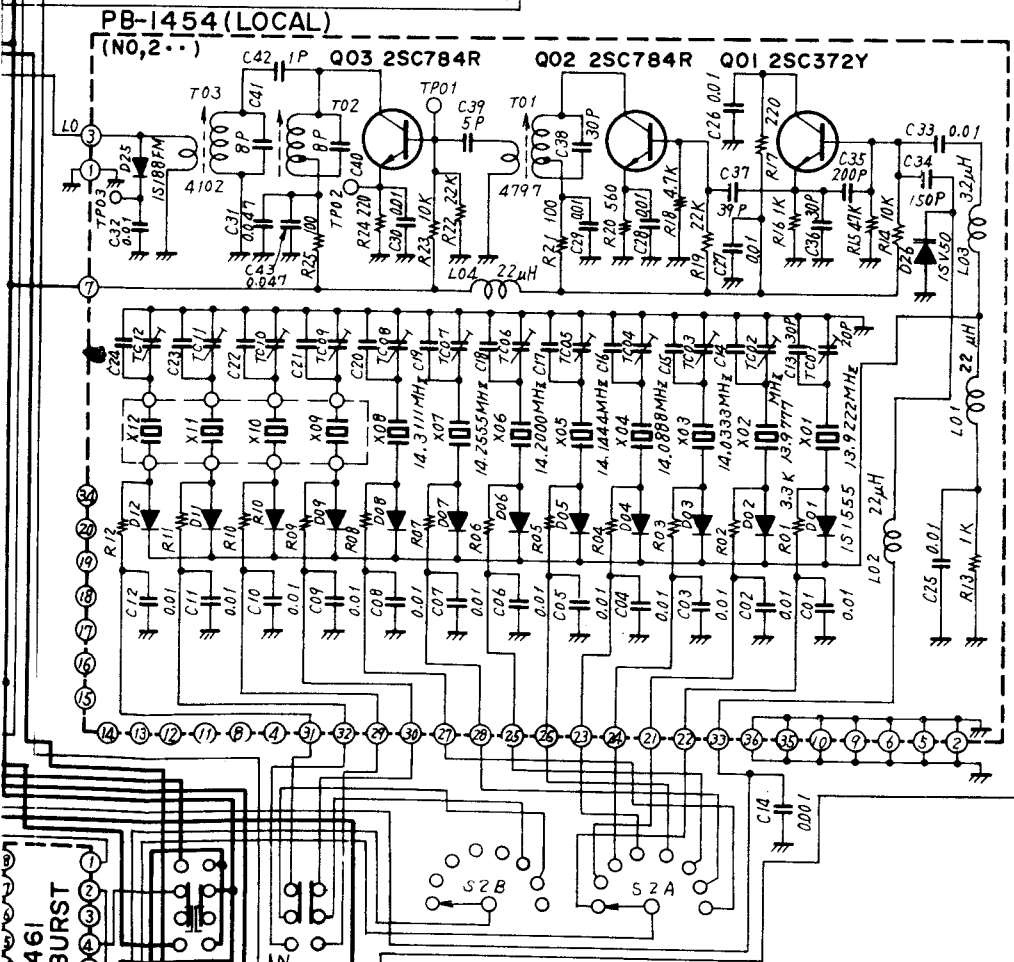
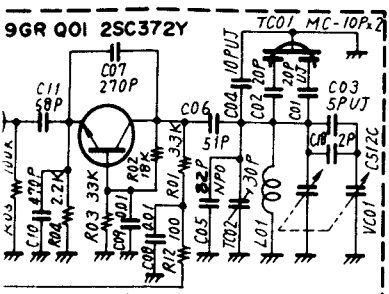
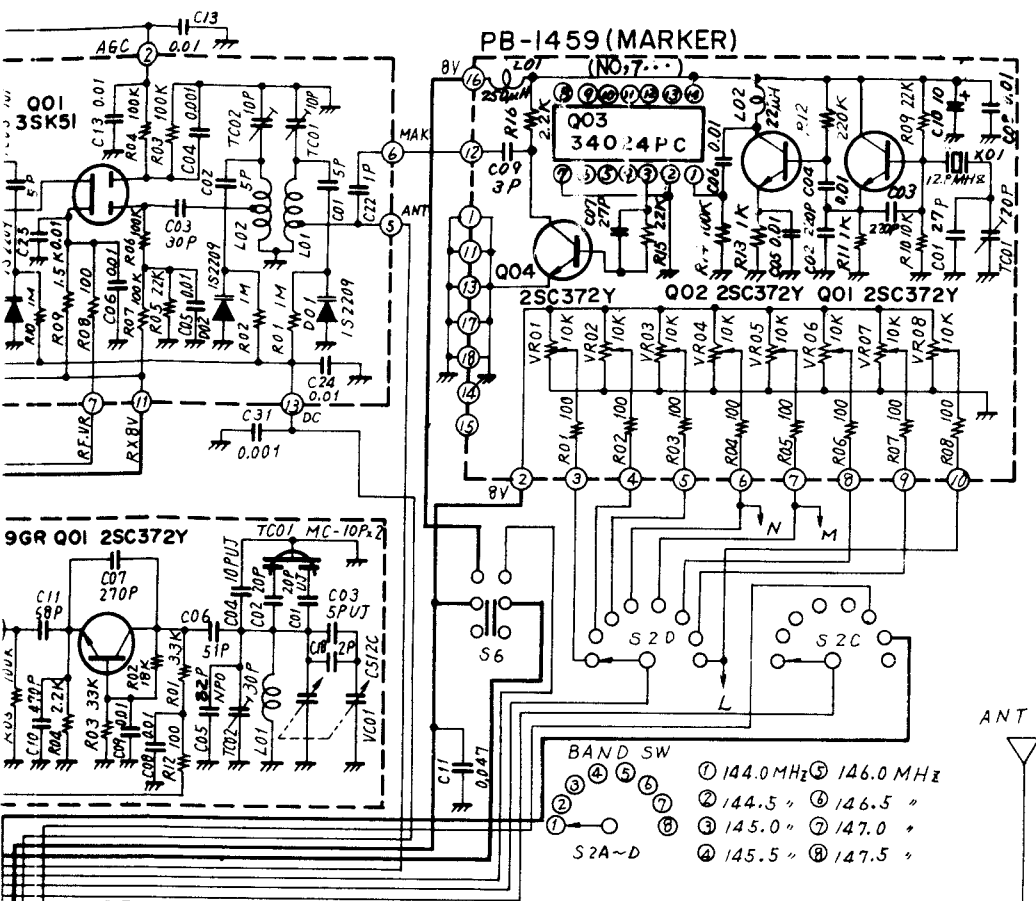

**NOTE:**

1. ALL RESISTORS IN  $\pm 10\%$  UNLESS OTHERWISE NOTED
2. ALL CAPACITORS IN  $\mu F$  UNLESS OTHERWISE NOTED
3. THE PARTS NUMBER WITH THE NUMBER SHOWN BELOW THE PRINTED BOARD DESIGNATION

**FT-221**  
**CIRCUIT DIAGRAM**