

Yaesu FT-100 undocumented



TABLE OF CONTENTS

MENU SETTINGS OVERVIEW	3
AT-11MP AUTOTUNER	7
ATAS-100 AUTOTUNING	8
<i>WHAT'S IN THERE?</i>	13
<i>HOW DO I TAKE IT APART?</i>	14
<i>HOW DO I PUT IT TOGETHER?</i>	14
ATAS100 MANUAL TUNING	14
ATAS-1/ATAS-2 SETTINGS	15
ATBK100 GROUND PLANE KIT	15
CWID WITH ARTS.....	16
BAND DATA PIGTAIL PINOUT	16
CTCSS AND MEMORY FUNCTIONS	16
DUPLEXERS.....	17
EXTRA BANDS	17
FACTORY MODIFICATIONS.....	17
<i>Intermittent High SWR ICON</i>	17
<i>Thermal modification</i>	20
FC-20 AUTOTUNER	24
FIRMWARE UPGRADES	25
KEYPAD FREQUENCY ENTRY	25
MANUAL REVISIONS	25
MEMORY PROGRAMMING	26
MIC ADAPTER	27
MIC BUTTONS.....	28
MICROPHONE MODIFICATION.....	29
MODIFICATION FOR OUT-OF-BAND TRANSMISSION	29
OUTPUT POWER (MEASURED IN AND OUT OF BAND).....	31
POWER CONNECTORS/LINE FILTERS	34
PSK31/SSTV/ETC. SOUND CARD INTERFACE WITH THE FT100.....	34
PROBLEMS WITH FT100 RADIOS	37
REPEATER OFFSETS	37
RF EXPOSURE.....	37
TRANSMIT PROBLEMS ON 80/160M.....	38
S-METER ANOMALIES	38
SATELLITE OPERATIONS	40
SEPARATION KIT (YSK100).....	41
SERIAL NUMBERS	41
SIDETONE/BEEP VOLUME ADJUSTMENT	41
SQUELCH SETTINGS FOR FM AND SSB	42
STORING MEMORIES REMOTELY	42

SWR METER INTERPRETATION	42
UP/DOWN BAND SWITCHING	43
V/U MESFET PRE-AMP ADJUSTMENT	43
YAESU CONTACTS	44

Menu settings overview

Nr.	Function		Default	Opt. 1	Opt. 2	Opt. 3	Opt. 4	Opt. 5	Remarks
1	Dial Pulse	tuning rate	200	100	200				
2	Beep	key and buttons	on	on	oFF				
3	Scan Mode	scan restart	tinE	StoP	buSy	tinE			
4	Scan Speed	dwel time	10 ms	10	100				
5	Resume	hold time	5 seconds	1	10				
6	DW-time	polling interval	5 seconds	1	10				
7	DCS Code	104 codes	23	23	754				
8	DCS ENC/DEC	normal or invert	tn-rn	tn-rn	tn-rr	tr-rn	tr-rr		
9	ARTS Beep	beep mode	ALL	ALL	rAng	oFF			
10	CW ID	enable/disable	oFF	on	oFF				
11	ID	up to 8 char.							
12	Tone freq	39 tones	88.5	67	254				
13	Dimmer set	63 dimmest	oFF	oFF	63				
14	Peak Hold	.5 sec hold	oFF	on	oFF				
15	Scope moni	sweep mode	oFF	Cont	Chec	SgL	oFF		
16	DSP mic eq	equalization	oFF	oFF	1 hi cut	2 lo cut	3 mid only		
17	DSP NR	reduction level	7	1	16				
18	DSP LPF	high cut	6000	1000	6000				
19	DSP HPF	low cut	100	100	1000				
20	BPF Width	DSP CW filter	240	60	120	240			
21	HF TX PO	power	100%	0	100				
22	50M TX PO	power	100%	0	100				
23	144M TX PO	power	100%	0	100				
24	430M TX PO	power	100%	0	100				
25	Mic Gain	SSB-AM modes	50%	0	100				
26	FM Mic Gain	FM mode	50%	0	100				
27	Comp Level	SSB-AM modes	50%	0	100				
28	AFSK Level	input sensitivity	50%	0	100				
29	APO Time	hours to shutoff	oFF	oFF	1	2	3		
30	TOT Time	minutes	20	oFF	1	20			
31	CW-W Filt	optional wide path	oFF	oFF	on				
32	AM/CW-N Filt	AM or CW-N filter	oFF	oFF	300	6_0			
33	FM Dev	deviation	HF 2.5 KHz	HF 2.5	2.5	5_0			
34	AFSK mode	mode-sideband	PCt-F	rtty-L	rtty-U	PCt-L	PCt-U	PCk-F	
35	RTTY Shift	frequency shift	170	170	425	850			
36	RTTY display	offset	nor	nor	Car				
37	Packet rate		1200bps	1200	9600				
38	Packet display	offset	2125	-3000	3000				
39	Packet tone	set for TNC	2125	1170	1700	2125	2210		

40	HF RPT SHIFT	10m shift	0.1	0	10MHz				
41	50 RPT SHIFT	6m shift	0.5	0	10MHz				
42	144 RPT SHIFT	2m shift	0.6	0	10MHz				
43	430 RPT SHIFT	440 shift	5	0	10MHz				
44	144M ARS	auto shift on-off	on	oFF	on				
45	430M ARS	auto shift on-off	on	oFF	on				
46	Keyer Type	keyer or paddle	EL2	EL1	EL2	buG			
47	Dot Size	dot to space	10	0	125				
48	Dash Size	dash to space	30	0	125				
49	CW-Delay	semi QSK	.5 sec	0	2.5				
50	CW Pitch	sidetone offset	700	400	500	600	700	800	
51	CW Break-in	QSK	FULL	FULL	Seni				
52	Keyer Speed		50	1	100				
53	QSK Delay	shifts output times	5	0	30				
54	VOX gain	input sensitivity	50	0	100				
55	Vox delay	hang time	.5 sec	0	2.5				
56	SQL/RF gain	mode of control	SqL	SqL	rF				
57	Lock mode	lock mode	diAL	PAnEL	diAL				
58	AM&FM Click	select knob function	on	on	oFF				
59	Mic SW set	mic buttons	1	1	2	3			
60	NB Level	IF noise blanking	10	0	16				
61	Tuner/ATAS	device selection	oFF	AtAS-1	AtAS-2	tunEr			
62	RX LSB CAR	Carrier point	0	-0.2	0.5				
63	RX USB CAR	Carrier point	0	-0.2	0.5				
64	TX LSB CAR	Carrier point	0	-0.2	0.5				
65	TX USB CAR	Carrier point	0	-0.2	0.5				
66	5167.5 KHz	Alaska emergency	oFF	oFF	on				USA only

There is a second set of factory / service menu functions F01 to F59. **WARNING:** changing these may reset all the memories. If you intend to make any changes, record all the original values first. Most of these settings are unique to each radio and are determined by using alignment procedures described in the FT100 Service Manual. Do not change these values unless you are sure of what you are doing. To activate them put the transceiver in VFO mode and turn it off. Press and hold the A,B,C keys; while holding them in, press and hold in the [PWR] switch for 1/2 second to turn the transceiver on. Now let go of all keys. Then press and hold the FUNC key for 1/2 second to get to the menu and then rotate the select knob to get to a second menu (F01 to F59) after #66 or before #01. When you turn the rig off and back on it returns to the normal menu.

Nr.	Function	Default (may vary)	Set to:	Remarks:
F01	144 RF GAIN	166		
F02	430 RF GAIN	166		

F03	HF RX IF G	98		
F04	50 RX IF G	112		
F05	144 RX IF G	108		
F06	430 RX IF G	82		
F07	S FULL SCALE	144		
F08	SSB SQL	33		
F09	FM N SQL	88		
F10	FM RF SQL	56		
F11	HF IC ALC	23		
F12	V/UHFIC ALC	22		
F13	HF PO 10W	26		
F14	HF PO 50W	83		
F15	HF PO 100W	123		
F16	50 PO 10W	25		
F17	50 PO 20W	45		
F18	50 PO 50W	83		
F19	50 PO 100W	123		
F20	70 PO 10W	063 <<< 70 MHz		
F21	144 PO 20W	65		
F22	144 PO 50W	120		
F23	430 PO 20W	139		
F24	1.8 TX IF G	76		
F25	3.5 TX IF G	69		
F26	7 TX IF G	63		
F27	10 TX IF G	63		
F28	14 TX IF G	67		
F29	18 TX IF G	71		
F30	21 TX IF G	72		
F31	24 TX IF G	72		
F32	28 TX IF G	75		
F33	50 TX IF G	104		
F34	70 TX IF G	127		
F35	144 TX IF G	97		
F36	430 TX IF G	93		
F37	ALC METER	196		
F38	HF PO METER	170		
F39	50 PO METER	172		
F40	144 PO METER	105		
F41	430 PO METER	63		
F42	HF REV ALC	34		
F43	50 REV ALC	34		
F44	70 REV ALC	127 <<< 70 MHz		
F45	144 REV ALC	173		
F46	430 REV ALC	60		
F47	SWR METER	141		
F48	OVER HEAT 1	230		
F49	OVER HEAT 2	235		
F50	CW CAR LEVEL	166		
F51	AM CAR LEVEL	113		
F52	FM TX FREQ	-32.47		
F53	TRX LSB CAR	0.11		
F54	TRX USB CAR	-0.01		

F55	blank			
F56	blank			
F57	DESTINA HF	USA < JPN,JAIA, STD,EU,FRAN,BEL, GER,USA,AUS,UT		
F58	DESTINA V/U	USA < JPN,USA, EU1,EU2,EU3,EU4, AUS		
F59	blank			

AM Settings

Gary Mitchelson, N3JPU, has done some interesting tests with the AM settings and found some settings that work much better than the defaults. The parameters that sound the best are: PO set to 25, Mic gain to 40 to 50 and Carrier Level set to 225 (F51 menu). You can hear a sample of his testing at: <http://mywebpages.comcast.net/n3jpu/>

Most owners who have had difficulties with AM audio quality have reported that the 6k HZ option AM filter (p/n XF117A) is an absolute necessity for both transmitting and receiving in AM mode.

The following procedure will result in excellent AM transmit operation with the FT-100(D). The User's Manual does not include any guidance regarding this. For this discussion I assume HF AM operation.

- Install the 6 kHz filter. You need the filter in order to have proper AM operation.
- Turn on the unit while holding in the A, B and C buttons in order to access the sub-menu "F" functions.
- Place the unit in AM mode.
- Set the MIC gain setting to 17 (seventeen).
- Using the F51 function, key the mic and set your un-modulated carrier output power to 25 Watts, no higher.
- That's it. You should now have 100 Watts PEP on voice peaks which is 6 dB (4 times) the un-modulated carrier power.

Extra hints: Set function F15 to 170 in order to avoid non-linear compression on voice peaks. But note the original setting and restore F15 to the factory setting when you operate SSB and CW. You should have 100 Watts output in CW mode when F15 is properly set.

You can use the speech processor during AM operation but you must not exceed a setting of 17 when using it, just as with non-processed operation. The PROcessor control is simply a second MIC gain control which over-rides the MIC gain control setting whenever you enable the PROcessor. The FT-100(D) actually does not allow you to vary the compression percentage.

AT-11MP Autotuner

Some owners have opted to purchase the AT-11MP auto tuner from LDG Electronics. This is available in either a kit or assembled format and does not suffer from the CAT/FC-20 limitations.

There is an accessory for the FT100/D called the OTT or 'One Touch Tune' available from W4RT.com that allows you to use the 'Tune' button on the FT100 to control the tuning function of the AT11 directly from the FT100. It also allows you to maintain the CAT compatibility which is something you normally lose with the FC-20 autotuner.

ATAS-100 Autotuning

The tuning behavior of the ATAS can cause confusion unless you understand the algorithm it follows to find a good position. Normally, if the ATAS is installed correctly and it successfully autotunes itself, it will always go in the correct direction when you press in the TUN button for 1/2 second once it has found its first good match. However, if the ATAS cannot find a match, it will run all the way to one end, turn around, and start over. This process can take a while since the antenna runs 'open loop' when it loses its position. Since it doesn't know which position the antenna is in unless it makes its own successful match, it needs to be sure it has gone all the way to the end before reversing, which can take a very long time.

Anytime it is not sitting right where it found a match all by itself, it can end up starting out in the wrong direction next time. Examples would be if you manually do even just a little fine tuning, or if you interrupt autotuning and change bands. Then the rule is very simple: it starts the next autotune by going in the last direction it was going in, which is not necessarily right. If it's going in the wrong direction, the antenna will move all the way to a stop and then it will have to turn around and start over again after a long delay. If you recognize that it's going in the wrong direction, you can avoid the long delay by aborting the autotuning process by hitting the TUN key momentarily, then manually move the antenna just a little (with the PTT and up or down keys) in the correct direction, and then recommence with the autotuning procedure.

ATAS-100 Disassembly

ACTIVE TUNING ANTENNA SYSTEM ATAS-100 Technical Supplement

©1998 Yaesu Musen Co., Ltd Printed in Japan.

E12959000 (9804a-0K)

YAESU MUSEN CO., LTD.
1-20-2 Shinonome-ku, Ota-Ku, Tokyo 146-8549 Japan
YAESU U.S.A.
17210 Edwards Rd., Centos, CA 90703 U.S.A.
YAESU U.S.A. INTERNATIONAL DIVISION
10913 North West 30th Street, Suite #105, Miami, FL 33172 U.S.A.
YAESU EUROPE B.V.
Schipweg 3, 1118DN Schiphol, The Netherlands
YAESU UK LTD.
Unit 2, Maple Grove Business Centre,
Lawrence Rd., Hounslow, Middlesex, TW4 6DR, U.K.
YAESU GERMANY GmbH
Am Kronberger Hang 2, D-65824 Schwalbach, Germany
YAESU HK LTD.
11th Floor Tsim Sha Tsui Centre, 55 Mody Rd.,
Tsim Sha Tsui East, Kowloon, Hong Kong

Specifications

- Frequency Range: 7/14/21/28/50/144/430 MHz Amateur Bands
 - Height (Approx.): 1.4 ~ 1.6 meters (4.59 ~ 5.24 feet)
 - Weight (Approx.): 930 g (2.05 lbs.)
 - Input Impedance: 50 Ω
 - Max. Input Power: 120 Watts (SSB)
 - Matched SWR: Less than 2.0:1 (with proper counterpoise)
- (Specifications subject to change without notice or obligation)*

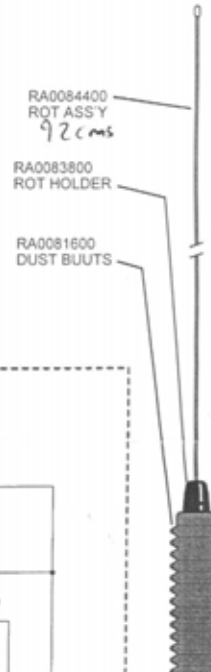

Circuit Diagram

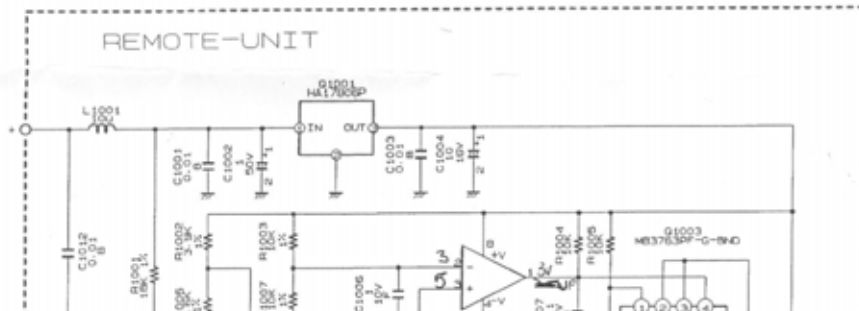

Parts Layout

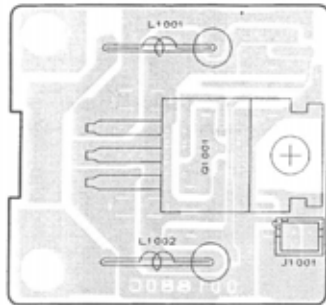

Component side

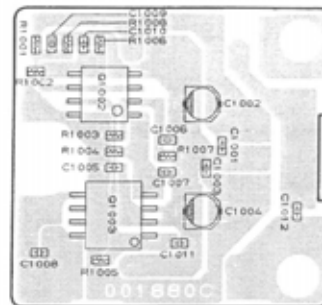

Chip side

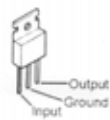

HA17806P
(Q1001)



NJM2903M
(Q1002)
MB3763PF-G-BND-TF
(Q1003)

Parts List

REF.	DESCRIPTION	VALUE	V/W	TOL	MFR'S DESIG	YAESU P/N	VERS.	LOT
*** REMOTE-UNIT ***								
	PCB with Components					S8100649		
	Printed Circuit Board					FR002420A		
J 1001	CONNECTOR				B 2B-ZR	P0090647		
C 1001	CHIP.CAP.	0.01uF	50	B	GRM39B103M50PT	K22174823		
C 1002	AL-ELECTRO-CAP.	2.5	50	B	ECF105B105R	K1813002		

Mechanical Details (Exploded Views & Mechanical Parts)

Screw KIT (YAESU P/N: S8001571)

S6000375
STOP RING

Description	YAESU P/N
LENCH F/SCREW	S8001569



Disclaimer:

The following procedures can possibly void your warranty.

WHAT'S IN THERE?

(And a little on how it works)

The stainless steel whip is mounted on top of a loading coil (under the rubber boot). The coil consists of copper wire wound around a "grooved" fiberglass rod. Part of the reason the antenna is guaranteed to work on 40,20,15 and 10m HF bands but not on 12,17 and 30m is that the spacing on the coil is wider at the resonant points on the coil on the "primary" bands allowing easier tuning.

The loading coil slips into the "body" of the antenna where spring loaded contacts make the necessary connections. At the base of the coil and rod is a Teflon disk that makes sliding contact with the inside of the tube and is threaded for the brass "screw" rod that raises and lowers the coil.

About 7" below the contacts is the motor and clutch assembly (at the middle rubber cover). Two wires run from the motor to the controller board that is mounted on top of the base unit.

The base (matching unit) consists of a chromed top cap which includes the mount for the motor controller board. Below this is a 3" black plastic tube that forms an insulator. At the bottom is the threaded chromed base cap that is where the SO-239 connector screws

in. This base assembly is secured with pins and would be hard to disassemble without damaging.

Inside this is an RF choke coil (I'm not sure if it is air wound or on a toroid) that makes this whole antenna DC grounded. This protects the radio from damage from whip contact with power sources, static build up, etc. The coil also helps with matching the antenna and contributes to the high Q of the design.

Connected to this is a capacitor that leads to the center pin on the SO-239 receptacle in the base. This capacitor is also part of the "broad band" matching network.

HOW DO I TAKE IT APART?

1. Extend the antenna fully (40m).
2. Remove from vehicle and take it to a clean work surface.
3. Remove the whip for ease of handling.
4. Slide up the 2 rubber covers exposing the screws.
5. Remove the 3 lower screws above the base.
6. CAREFULLY remove the base by gently pulling down while using a slight rocking motion (the resistance is from a O ring).
7. Carefully withdraw the base assembly while noting the routing of the motor wires.
8. Unplug the micro connector from the motor controller board (the red and black wires that leads to the motor-clutch assembly), and set the base aside.
9. Mark on the shaft the location of the bottom of the boot, then slide the boot upwards exposing the loading coil.
10. Remove the remaining 6 screws on the antenna.
11. Carefully slide up the loading coil which also removes the motor-clutch assembly (be careful with the alignment pin).

There is more than can be disassembled, but the above steps are all that is needed for most maintenance and repairs. While you're in there, clean the moving surfaces up and oil with a light oil (like mineral oil) that won't harm plastics while taking care not to contaminate the contacts, coils and connections.

HOW DO I PUT IT TOGETHER?

1. Basically reverse the above procedure.
2. Be careful to make sure the alignment pin (about 7" long) from the loading coil to the motor-clutch assembly is in place.
3. Pay special attention to the routing of the motor wires to prevent pinching between the motor controller board and motor-clutch assembly.

ATAS100 Manual Tuning

The ATAS100 can be tuned up and down manually by holding in on the PTT switch and using the UP/DOWN keys on the front of the radio. If you thought it meant the UP/DOWN keys on top of the hand mic, you're not alone, as several others have made the same mistake and the manual does not specify which UP/DOWN keys to use. It has been noted that the P1/P2 keys on the mic will cause the antenna tune icon to come on if you push them while holding the PTT, but they do not actually move the antenna.

ATAS-1/ATAS-2 Settings

Menu item 61 has several settings for controlling the way the ATAS100 antenna works. In the user manual, there are several errors describing this function. On page 14, the instructions are correct and the easiest way to remember the correct settings are: ATAS-1 = one antenna ; ATAS-2 = two separate antennas. In other words, if you're using the ATAS100 on all bands (with a duplexer), choose ATAS-1. If you are using the ATAS100 for HF only and a separate antenna for VHF/UHF, use ATAS-2. Page 62 in the manual is backwards from this as is page 94 which recommends that a duplexer is required with ATAS-2. The newer manuals may have corrected these errors but as of manual revision E08981003 the mistakes were still present.

Another user noticed that when either of these selections are made, the radio will not transmit on the 80 or 160 meter bands so don't forget to switch menu item 61 to OFF (or to Tuner) when you switch from the ATAS100 to another antenna.

ATBK100 Ground Plane Kit

The ATBK100 is a kit consisting of 3 ground radials for the ATAS100 intended to make it suitable for use as a base antenna. Although there is no information available on the Yaesu website about the ATBK100, this US\$90 kit is supposed to supply a ground plane for the 50 MHz, 144 MHz, and 430 MHz bands. One owner responded that he was able to get the antenna to work on other HF bands by adding two 20' lengths of wire to the ATBK100 to act as a counterpoise.

Audio Settings (improving transmitted audio performance)

Bill, N4XEO, has contributed the following advice for those who are not satisfied with their audio reports. First, make sure the rig's chassis is grounded to the frame of the vehicle and that the rig is powered directly off the battery with minimal voltage loss through the power cable. Secondly, make sure that the voltage is sufficient for the rig. The specifications call for 13.8V DC and so if you're not running the engine, it's likely that your voltage won't run the rig correctly for very long. This will be apparent when operating with the engine off as the battery voltage begins to sag down around 12V.

Here are some of the settings Bill recommends that have worked for him and others to improve the audio:

Menu Item	Description	Value
25	Mic Gain (for SSB and AM modes)	40
26	FM Mic Gain	45
27	Compression Level	40
33	FM Deviation	5
62	RX LSB Carrier	+050
63	RC USB Carrier	+050
64	TX LSB Carrier	-200
65	TX USB Carrier	-200

CWID with ARTS

The CWID feature appears to have a bug. It sends out the 'W' as a 'U' in Morse code. The CWID feature, when enabled, transmits a CW identifier every 10 minutes when the radio is operating in ARTS mode. Here is a set of instructions on how to test if your radio is affected:

Go to menu item 11 and enter a CW ID string with some W's in it. To do this, press Select knob and use the main dial to select the characters. Press the Select knob to advance one character. Program all 8 characters using the Select button to advance. When you get them all programmed, press Select again and the radio will playback the ID you've stored. Use a tape recorder unless you think you can copy comfortably at 35-40 wpm. If you want to hear it on the air, proceed with the following instructions.

Go to menu item 10 and enable the CW id during ARTS operation.

Set the radio to a clear simplex FM frequency.

Press the FUNC key until you get to screen 3 which shows TON DCS and ART. Enable ART.

Listen on another radio. The DCS code will be sent every 15 seconds and the CW ID will occur every 10 minutes. Again, use a tape recorder, as the ID comes across at about 35-40 wpm. I have a little recorder that will allow me to record at 2.4 cm/sec and play back at 1.2 cm/sec so I can listen to the CW at a more comfortable 18-20 wpm.

Band Data Pigtail Pinout

The Band Data pigtail can control a VL-1000 amplifier when set internally to control an amplifier. The normal mode is for the CAT/Tuner function, but it can be rearranged with an internal jumper (shown on page 19 of the manual) to control an amplifier. If you're curious about how the signals work in that mode, the table below shows the logic depending on the band selected. The images to help explain this better are shown here.

Yaesu FT-100D Band Data Output map H=4.4 vdc L=0 vdc

Band	1.8	3.5	7	10	14	18	21	24	28	50	144	440
A	H	L	H	L	H	L	H	L	H	L	H	L
B	L	H	H	L	L	H	H	L	L	H	H	L
C	L	L	L	H	H	H	H	L	L	L	L	H
D	L	L	L	L	L	L	L	H	H	H	H	H

CTCSS and memory functions

Storing CTCSS frequencies in memory along with frequencies is a bit tricky. When putting frequencies into memory from the VFO you must have encode on and the display

must show ENC for the CTCSS tone to go into memory. If the main display does not show ENC when the frequency is put into memory, the CTCSS setting is not stored.

Duplexers

The ATAS100 is designed to tune on all the bands on which the radio transmits including 2m and 70cm. This requires a duplexer like the Diamond MX62M or the Comet CF706 to connect the VHF/UHF and HF pigtails together. (The actual cross-over frequency between the pigtails is 70.5Mhz.) However, many people prefer to use a separate antenna for the VHF/UHF bands since those antennas typically cost about the same price as a duplexer and usually have some gain whereas the ATAS100 has no gain on VHF/UHF. Also, with separate antennas you don't have to worry about retuning when switching between VHF/UHF and HF.

A consideration when using a duplexer is that the DC voltage for tuning the ATAS-100 is supplied through the HF pigtail. Therefore, this pigtail must always be connected to the ATAS for tuning purposes. Also, it must not be capacitively coupled inside the duplexer or it will block the DC motor control voltage.

Extra Bands

You may have noticed two extra bands appear while moving through the normal ham bands using the up/down keys. Apparently, the rig remembers an extra band for HF and another for V/U portions of the radio. If you tune outside a normal ham HF band either accidentally or intentionally, you'll notice that this band will now appear in a list of bands as you use the up/down keys. The same is true for the V/U side of the radio. For example, if you tune to the weather band at 162 Mhz, it will appear in the list between the 2M and 70cm bands. Short of resetting the radio, there's no way to get rid of these bands. Some have elected to move them to the end of the list by tuning a frequency below 160M or above 70cm so that they don't appear inside the list of bands.

Factory Modifications

There are two common modifications retrofitted to the FT100s manufactured prior to 2001. These include the fixes for the Intermittent High SWR ICON problem and the VHF/UHF thermal sensor modification to enable the fans in the V/U receive mode. Although there had been reports that new radios included the SWR mod, the mod has been through several iterations and it's possible that even radios purchased today do not include the 'final' mod with the screws, but rather just the copper tape held on with adhesive.

Intermittent High SWR ICON

Some owners have had trouble with the HIGH SWR Icon appearing while attempting to transmit on certain bands. The most common advice is to make sure that the antenna mount and radio are properly grounded via some heavy braided material to the vehicle chassis. Some owners have had success in using clamp-on ferrites with the separation kit

cable wrapped several times around the ferrite to block common mode current from getting back into the rig. Ten meters seems particularly prone to the problem. Changing the feedline length has also helped in some cases, but this seems to move the problem around more than solving it at the root cause. Also, some owners have found that fixing the grounding of the LPF board by adding solder around the screw holes and in some cases tightening the screws or adding star washers was sufficient to make their grounding problems go away.

However, there is a very effective modification that has worked in every case. The mod involves fixing the grounding in the coax sockets on LPF of the radio and a metal shield on the Main Unit. A degradation in the LPF grounding can cause the rig to break into oscillation (even at lower power) causing the HIGH SWR icon to appear intermittently even with a good antenna match on the higher HF bands. The mod will eliminate this oscillation and the high SWR reports. Here are a few pictures of the factory installed mod. The adhesive copper tape has been replaced screws or clamps that are attached to the casting web. Note that on the upper strap, they have added a screw and the lower strap was added and soldered to the shield as well as the coax and also screwed to the casting.



Before the factory mod



After the factory mod



After the factory mod.

The SWR icon with an 'X' next to it indicates that the SWR is out of range. If you see an SWR icon with an 'O' next to it flash momentarily, it is an indication that the antenna has finished tuning and the SWR is 'OK'.

Thermal modification

The cooling fans will only work during transmission when the radio is tuned to 70.500 MHz or higher. Yaesu will fix this by mounting a thermal switch that bypasses the electronic fan control circuit. The thermal mod is done on an 'as requested' basis since Yaesu feels that keeping the fans off in V/U receive poses no threat of overheating the radio.

A simpler way to do it yourself is to add a 50 to 120 ohm / 1 Watt resistor between one of the black wires of the fans and ground, for instance the chassis. The resistor value will determine the idle speed of the fans. Pick one that suits your preferences.

The pictures below show the Yaesu factory modification:



Prior to modification



Prior to modification



After modification

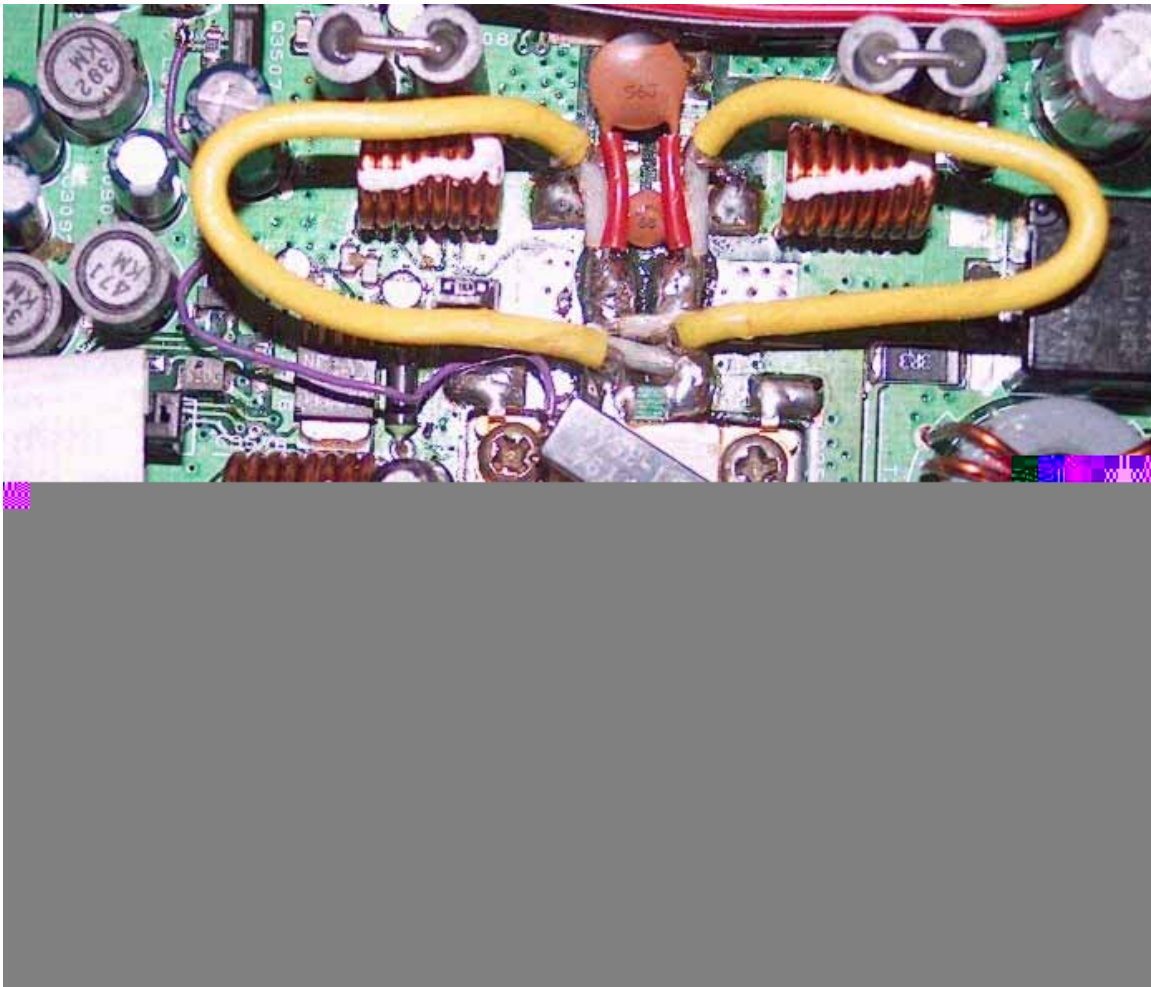

After modification

There is also a software work-around to get the fans running on 2 and 70 on RX only, by using the 'SPL' button and VFO A/B to turn on the SPLIT function.:

- Set the VFO "A" on the RX QRG on 2m or 70cm band and VFO "B" on a TX frequency on HF or 6m.
- Briefly press the TX PTT (which briefly transmits on HF or 6m)
- Now the fans are running full speed and will slow down in a few seconds without stopping entirely.

FC-20 Autotuner

The FC-20 auto tuner is available as an accessory for the FT-100. The FC-20 was designed specifically for the FT-847 and FT-100 and is intimately mated to them. The FC-20 is capable of matching a SWR up to 3 to 1. It features 100 memories that memorize your favorite frequencies so that when you return to them, the unit can "instantly" tune to a frequency without having to evaluate the SWR as it tunes. People have identified two limitations to the FC-20: the matching range and the inability to use both CAT control and the tuner simultaneously. If you don't need a wide matching

range and don't use the CAT control with the radio, then the FC-20 is reported to operate very smoothly and is well integrated with the radio. If these limitations are important to you should consider the LDG AT-11 autotuner.

Firmware Upgrades

A common question asked regarding the FT100 is whether or not its firmware can be upgraded to add some missing feature in the future such as memory management via a PC or keypad frequency entry. Unfortunately, the design of the FT100 does not allow for this kind of feature since the microcontrollers are not flash-based, but rather OTP (one-time programmable) devices or even mask-based in later production runs. They can be removed and replaced, but this takes special SMT (surface mount technology) soldering equipment.

There are three microcontrollers in the FT100:

- The FT100's main processor, mounted on the controller unit, is a 32MHz, 80-pin, 16-bit CPU from NEC (P/N UPD78P4038).
- There is also an 8 MHz, 48-pin, 8-bit microprocessor on the controller unit made by Fujitsu (P/N MB89P133PFM) that appears to be the one that does the electronic CW keying since it only has a few inputs and they connect to the 'key1 and key2' on the back of the unit. It uses a few of its serial pins to communicate with the main CPU. FMI see: the Fujitsu MB89P133PFM datasheet.
- The display board has a 5 Mhz, 80-pin, 8-bit NEC microprocessor (P/N UPD78P054) and that communicates with the main CPU via a serial link.

Keypad Frequency Entry

There is no way to key frequencies into the FT100 via the microphone's numeric keypad (standard on US models). That numeric keypad is only used for touch tone encoding when the PTT is held. However, John Hansen, W2FS, has designed an auxiliary keypad called the Millenium QSYer that can be used to enter frequencies from an external keypad. The cost is US\$70 for the kit or US\$95 for the assembled and tested unit. It can also be used with the Yaesu FT817 and Icom IC706 mobile radios.

For details and ordering see <http://www.john.hansen.net/keypad.htm>

Manual Revisions

The manual revision can be determined by the part number of the manual. This number is located directly below the barcode on the back cover of the manual and will have a format like 'E08981003'. The number on the lower left-hand corner of the back cover with the format such as 9907V-EY is the printing lot number and does not contain information relevant to the revision of the manual.

Another common question asked is where one can get a copy of the owner's manual, preferably on line. You can find it on <http://k0lee.com/images/FT-100D%20Manual.pdf>.

There is also an FCC site that has manual, schematic, and other information related to the submission for approval by the FCC. Unfortunately, this information is quite out of date since a product is normally submitted to the FCC well in advance of its actual availability and the manual is often just a rough draft of the finished manual. An exploded view of the rig can be found on <http://k0lee.com/images/FT100%20Exploded%20View.pdf>.

There is also an effort underway to make the alignment procedures available on <http://k0lee.com/techsupp.htm>.

The FCC site can be found at: <http://www.fcc.gov/oet/fccid/>. To get the information, use the Grantee code K66, and the equipment product code FT-100, and select View Exhibits. Here you may view schematics, photos, block diagram, parts lists and a PDF version of the user manual. The manual shown appears to be only a rough draft with 36 pages of information vs. 108 in the finished manual. It contains no illustrations. The manual and schematics were scanned and converted to .pdf and you will find resolution of the schematics is not high enough to be usable. It is highly recommended that if you lost your manual or bought a used radio without one, that you contact Yaesu Parts and purchase a new one.

Memory Programming

There are a few common difficulties in programming the memories. The radio has a mode to allow rapid tuning through the memories by skipping unused memory locations. This feature must be disabled to store frequencies in an unused memory location. To disable it, place the rig in memory mode by pressing the VFO/M button until MEM is shown in the display. Then hit the STEP key to enable or disable the vacant memories selection. Reverse the procedure with the same sequence. Turning the SELECT knob will help you to determine if the radio is in rapid mode if you see it is jumping over unused memory locations.

Another difficulty is getting the memories stuck in a particular memory group. The main memory [1-300] is divided up into 6 separate 50-memory groups. You can restrict tuning to a single group by pressing in on the SELECT dial for 1/2 seconds while in MEM mode. You reverse the procedure with the same sequence. You will see an GCH appear in the lower left hand corner of the display if you are locked into a particular memory group 1 through 6. Pressing the SELECT for 1/2 seconds will put it back in memory channel mode and it will display MCH in the lower left hand corner. If you are not careful and only press the SELECT momentarily, it will put you in VFO mode and you'll have to press the VFO/M key to get back into memory mode. This is not explained correctly on page 71 of the manual.

There are no provisions for alpha numeric labeling of the memories in the FT100.

Mic adapter

PowerWerx (www.powerwerx.com) sell an adapter to connect standard base microphones to the FT100. For the lordly sum of \$30,-- you are the proud owner of a short piece of wire with a cheap connector on both ends.



It might be cheaper to do it yourself. (In fact it is... *much* cheaper.) Here's what you need to know: The up/down/PTT switches are all connected to the SW1 line on the FT100 microphone jack. Different resistor values address different buttons:

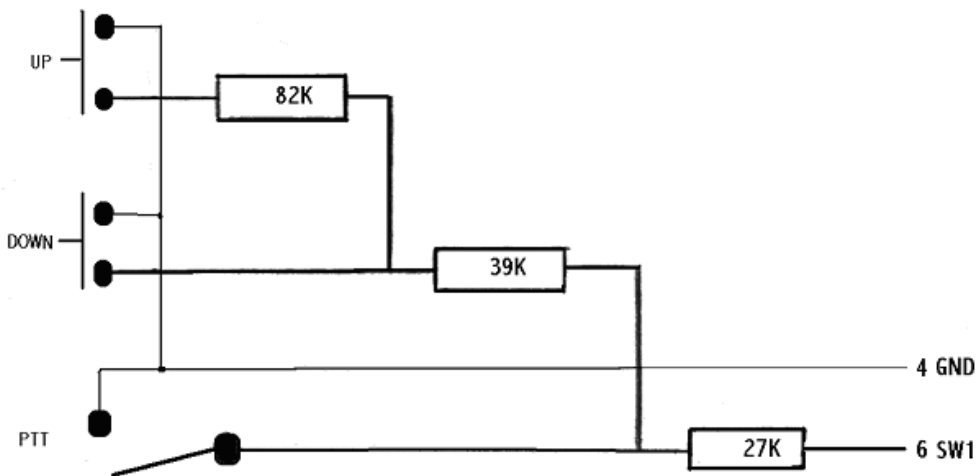

The pin-out on the FT-100 / 90 / 8100 Mic jack is as follows:

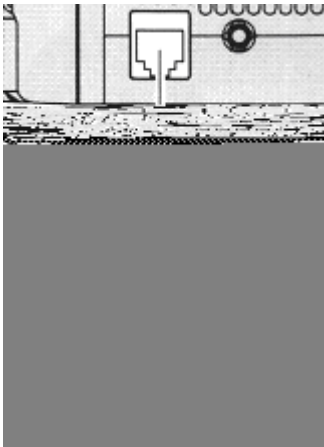

- Pin 1: SW 2 multi-function switching
- Pin 2: N.C. (9600bps packet data output FT-90)
- Pin 3: + 9 v
- Pin 4: GND
- Pin 5: Microphone Input
- Pin 6: SW 1 PTT, UP, DOWN

The circuit below gives you PTT, UP, DOWN, ACC, P, P1, and P. Don't forget that you can program the functions of P, P1 and P2 on the FT-100:

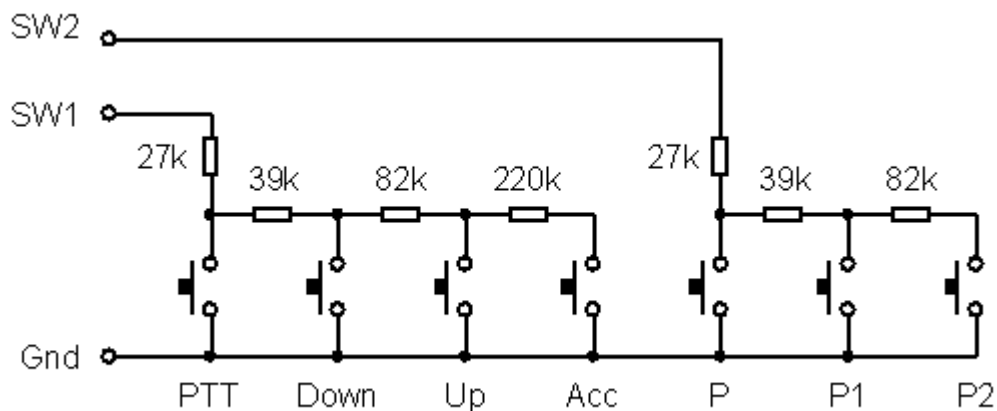

When you try to use various mics with the FT-100D you may find that you have muffled or very low apparent audio drive level. This may be due to the fact that the mic you are trying to use has a relatively high output impedance as compared to the input impedance of the FT-100D. This can result in the low audio and/or muffled transmit audio problems. There is a pre-amp design available at <http://hometown.aol.com/ampmicro>.

Mic Buttons

The microphone MH36B has a complete set of numeric buttons but they cannot be used for numeric frequency input. They can only be used to send DTMF tones in FM mode by holding in the PTT and simultaneously pressing the numeric sequence. There is no audio

feedback provided to the user while sending the tones. There are also 4 buttons labeled A, B, C, and D but there is no documented use for these keys.

Microphone modification

This modification to the stock microphone will bring you excellent transmit audio reports:

- Open the mic case.
- Remove the 3 larger internal screws and the 1 smaller screw in the microswitch.
- Move the PC board away from the tiny mic element so you can access it.
- VERY carefully remove the tiny electret mic element from its cylindrical housing using a fine tipped tool. Work it out beginning at the edge where you can pull on the rubber "grommet".
- Shake the plastic baffle out of the electret housing.
- Carefully force a sewing needle through the 3rd mic hole that's normally blocked.
- Insert the electret element back into its cylindrical housing carefully, leaving the plastic baffle out.
- Re-assemble the mic case.

Set the MIC gain to about 55 and enjoy the excellent transmit audio that was previously limited by the plastic "noise baffle". The improvement is dramatic.

Note that most hams in Europe seem to have an MH-42b microphone on their FT100/FT100D (the version without DTMF buttons). The MH-42b mic DOES NOT NEED THIS MOD. Instead of the two-out-of-three holes there is a slit in the mike housing, and the plastic baffle is made out of loosely compressed fibers in this version, which does not block sound noticeably. As a result, this mic doesn't have any audio problems. So if you have an MH-42b mic, just leave it as it is. :-)

Modification for out-of-band transmission

The FT-100 can be modified to transmit on frequencies outside the amateur bands. This modification opens the Yaesu FT-100 for full transmit on the HF, VHF, UHF bands. The mod works for both the FT100 and FT100D. It will not allow you to transmit on the 220 Mhz band. All memory channels will be lost. Repeater offsets remain intact for USA versions.



Back of front panel. Top left corner.

- Remove jumpers 1 & 2, leave 3 & 4.
- Remove Front Panel from radio and open the rear cover from the Front Panel unit. Be careful, a cable connects them together. Locate and remove R6035 (1) and R6036 (2) on the display board. Note: The factory removed R6035 on my radio so I only had to remove R6036. You should end up like the picture above.
- Reassemble and install the Front Panel on the radio.
- Note: if the 2 SMD diodes not are present, then you should skip the above steps.
- Press [DPS] and [LOCK] keys, while holding them in, press and hold the [PWR] switch for 1/2 second to turn the transceiver on. Wait for the transceiver to initialize itself. You WILL LOOSE all memory channels programmed. Turn the transceiver off.
- Press and hold [DWN] and [STEP] keys; while holding them in, press and hold in the [PWR] switch for 1/2 second to turn the transceiver On. Now let go of all keys. The display will read "r on" for a 1/2 second or less (it may be so quick that you don't see it but continue with the mod).
- Set the dial frequency to 375.72727MHz. You will need to use LSB, USB, or CW to get the last digits. After you enter 375.72727Mhz, press the MODE button to go back to FM Mode, and turn the power off
- Press and hold [DWN] and [STEP] keys; while holding them in, press and hold in the [PWR] switch for 1/2 second to turn the transceiver On. Now let go of all keys. The display will read "HF on" for a 1/2 second or less (it may be so quick that you don't see it but continue with the mod).
- Set the dial frequency to 549.61163MHz You will need to use LSB, USB, or CW to get the last digits.
- After you enter 549.61163Mhz, press the MODE button to go back to FM Mode, and turn the power off.
- Press and hold [DWN] and [STEP] keys; while holding them in, press and hold in the [PWR] switch for 1/2 second to turn the transceiver On. Now let go of all keys. The display will read "vU on" for a 1/2 second or less (it may be so quick that you don't see it but continue with the mod).
- The modification is complete. Turn the radio off and back on to continue.
- RX & TX: 1.8MHz-30MHz, 50MHz-54MHz, 140MHz-174MHz, 420MHz-470MHz.

The following Yaesu document also explains an out-of-band modification:

Model: FT-100	Date: 4-7-99
Caution	New Frequency Range

Output power (measured in and out of band)

Frequency MHz	100%		50%		10%		0%	
	dBm	W	dBm	W	dBm	W	dBm	W
432	43.3	21.4	39.3	8.5	33.5	2.2	30.8	1.2
145	47.1	51.3	43.2	20.9	37.4	5.5	35.2	3.3
50	49.7	93.3	45.1	32.4	42.5	17.8	35.0	3.2
28	50.0	100.0	45.3	33.9	38.1	6.5	35.0	3.2

24.9	50.0	100.0	45.3	33.9	38.1	6.5	35.0	3.2
21	50.0	100.0	45.4	34.7	38.1	6.5	35.0	3.2
18.15	50.0	100.0	45.3	33.9	38.1	6.5	35.0	3.2
14	50.0	100.0	45.3	33.9	38.1	6.5	35.1	3.2
10.1	49.9	97.7	45.2	33.1	38.0	6.3	35.0	3.2
7	49.8	95.5	45.2	33.1	38.0	6.3	34.9	3.1 **

Measured with HP432 + Narda 40dB attenuator

** Power sensor range from 10MHz to 12Ghz

All readings at 100% power on all bands:

Frequency (MHz)	Output (Watts)
2	82
3	83
4	82
5	83
6	83
7	88
8	80
9	85
10	84
11	88
12	86
13	81
14	80
15	82
16	84
17	68
18	85
19	85
20	82
21	85
22	83
23	85
24	85
25	85
26	85
27	81
28	81
29	71
30	62

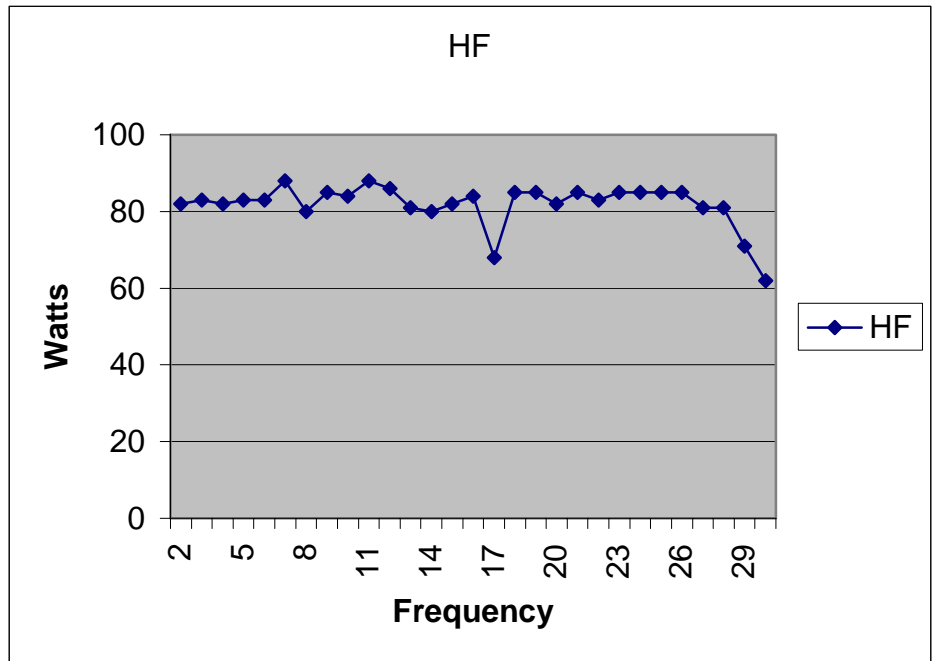

Frequency	Watts
50	32
51	34
52	35
53	32
54	28

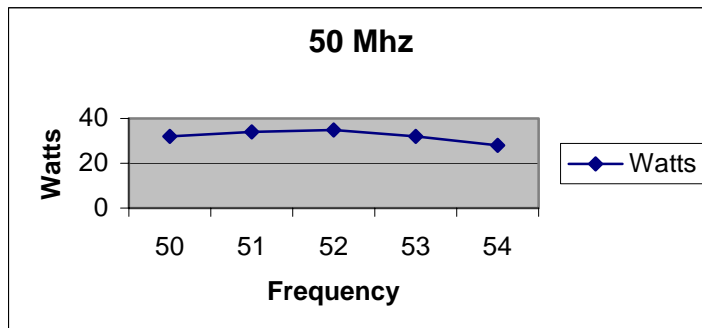

Frequency	Watts
-----------	-------

140	40
141	44
142	48
143	48
144	48
145	48
146	48
147	48
148	48
149	48
150	48
151	48
152	47
153	45
154	44
155	32
156	26
157	22
158	17
159	14
160	10
162	8
163	7
164	5
165	5
166	4
167	2
168	1
169	1
170	0.5

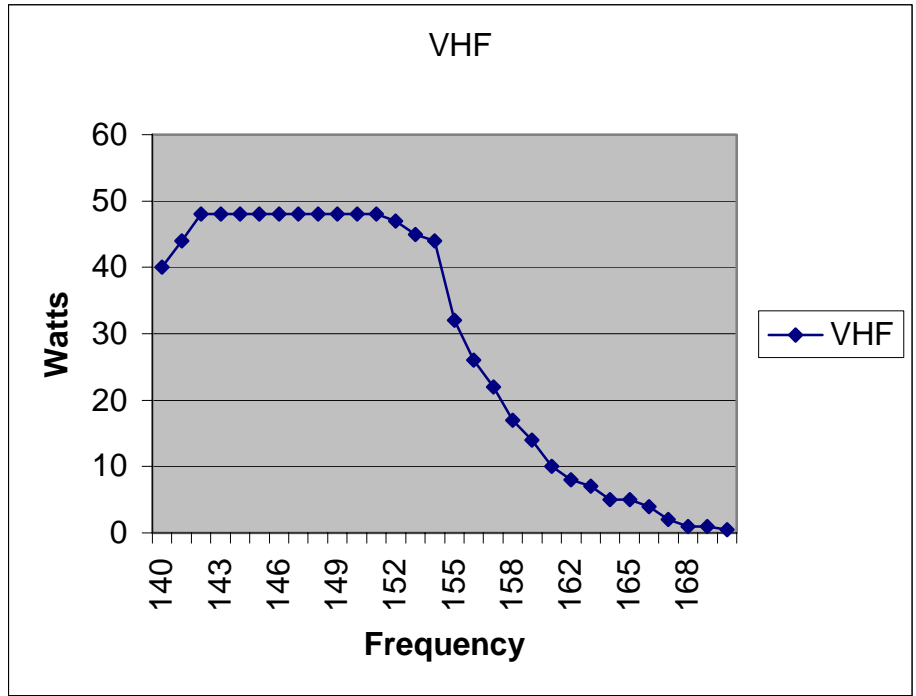

Frequency	Watts
420	5
421	7
422	11
423	16
424	21
425	23
426	23
427	23
428	23
429	23
430	23
431	23
432	23
433	23
434	23
435	23
436	23
437	23
438	22
439	22
440	22
441	22

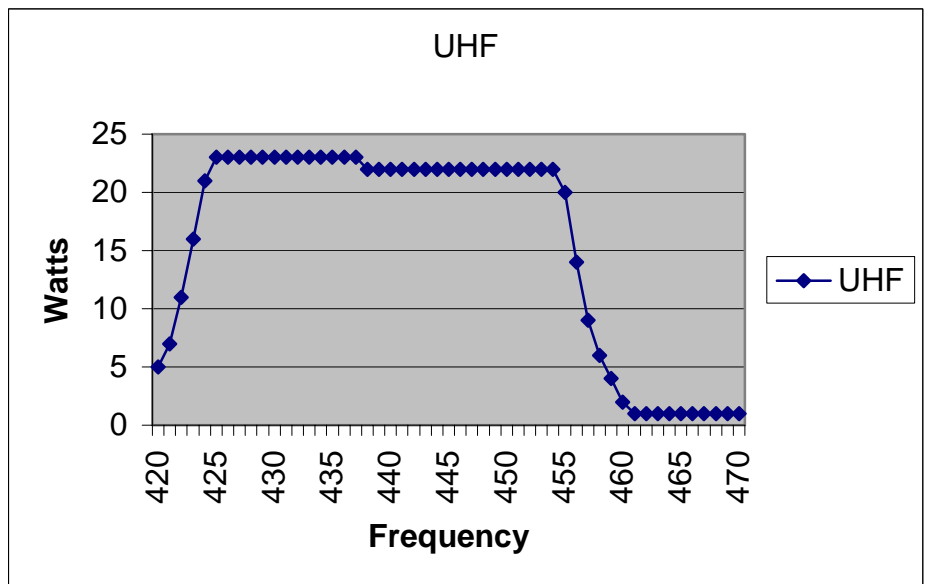

442	22
443	22
444	22
445	22
446	22
447	22
448	22
449	22
450	22
451	22
452	22
453	22
454	22
455	20
456	14
457	9
458	6
459	4
460	2
461	1
462	1
463	1
464	1
465	1
466	1
467	1
468	1
469	1
470	1

Power Connectors/Line Filters

An excellent source for power connectors can be found at www.powerwerx.com. They carry the OEM connectors and shells for the FT100 (and other rigs) as well as the Anderson Powerpole connectors which allows you to make up cables so that it's easier to interchange different brands of radios with various power supplies. They also carry line filters to reduce alternator whine from the DC power source.

PSK31/SSTV/etc. soundcard interface with the FT100

Operating soundcard programs like PSK31 is accomplished by using the DATA Jack on the rear panel of the radio. The definitions of the jack as provided on pages 20 and 21 of the manual are:

Pin 1: Data In (AFSK input for soundcard)

Pin 2: GND

Pin 3: PTT

Pin 4: 9600 Baud out

Pin 5: 1200 Baud out (audio out for soundcard)

Pin 6: Squelch

It is necessary to build a circuit or purchase and interface prior to using soundcard programs. There are several sources on the web that describe these interface circuits. You can find them at:

- <http://www.qsl.net/wm2u/psk31.html>
- <http://krasnodar.online.ru/hamradio/soundint.htm>
- http://www.qsl.net/kb8wow/Psk_Interface_Page1.html

If you would prefer to purchase an interface, there are several options:

- A kit complete with cables and enclosure \$25 (\$39 assembled)
<http://www.packetradio.com/PSK31.htm>
- Rigblaster complete kit fully assembled \$90 (but not available with FT100 data connector) <http://www.westmountainradio.com/RIGblaster.htm>
- Buscommco fully assembled interface \$50 configured for FT100
www.buxcommco.com

The cable for the DATA jack is the CT39 and costs U.S.\$10 from Yaesu. Jon, WA2NKF, put together a diagram on how to interface a soundcard to the FT100 using the CT39 or other 6-pin DIN connector. It is a very simple interface with a minimal number of external components to enable the PTT:

For Yaesu FT-100

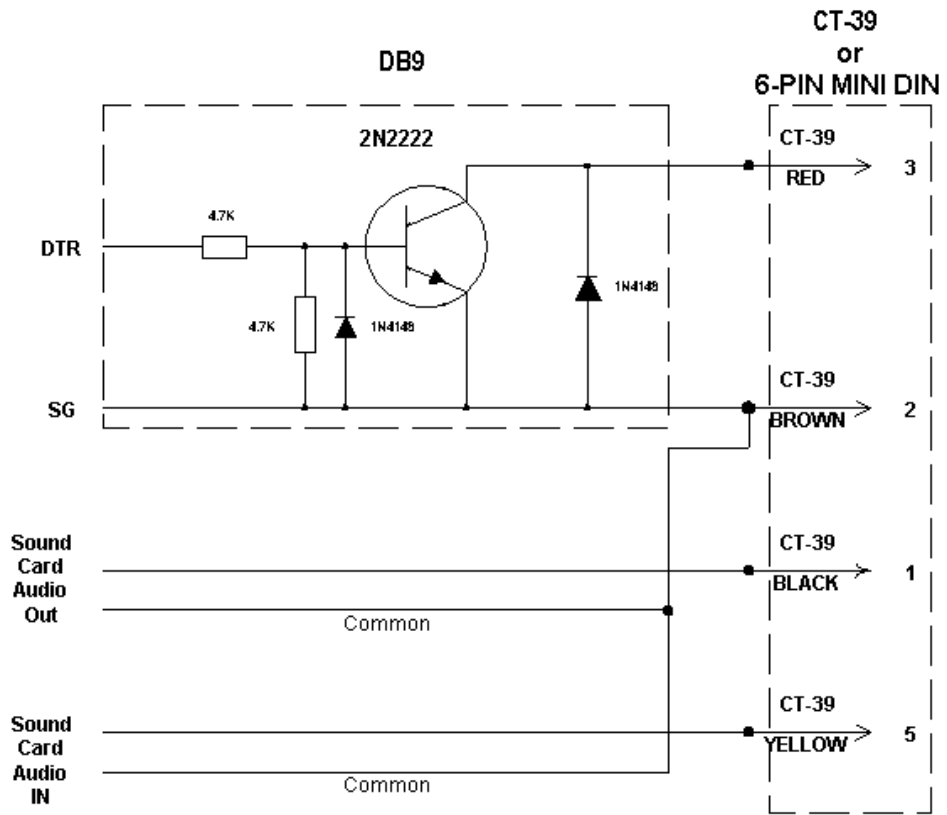

Signal Name	PINS ON DB25	PINS ON DB9
DTR	20	1
SG	19	2
Sound Card Audio Out	18	3
Sound Card Audio IN	17	4

Sandor, KG4FET, has had good success using the FT100 for PSK31 and recommends using the USB mode (not RTTY mode). Playing around with RTTY or AFSK mode settings on the FT100 will only cause confusion. Sandor also used 1:1 600-ohm isolation transformers on the TX and RX lines as well as an opto-isolator for the PTT.

Problems with FT100 radios

Several owners of the early FT100 radios experienced failures of the V/U output transistor. The word from Yaesu was that solder flux left on the board was to blame. Another common issue is related to the Intermittent High SWR ICON problem discussed elsewhere in this document. Overheating on V/U receive was also an issue on units manufactured prior to 2001 and can be fixed with a thermal sensor modification that Yaesu has applied as a retrofit. The ATAS100 antennas seemed to have a rash of early failures where they refused to move after a while. This appears to have been corrected with a new H bridge that drives the motor.

Repeater Offsets

The repeater offsets are determined by the values set in menu items 40-43. If you need to program a memory that has a non-standard offset, use the DUP memories since the repeater offset is not stored with the other parameters in the standard memory locations (1-300).

Frank, PA4FR, adds this information as an alternative to using DUP memories: FT-100 ARS (automatic repeater shift) might be activated for 2m and 70 CM bands separately. ARS is default enabled for both bands. When ARS is enabled, any (!) manual change to repeater offset or repeater on/off setting is overridden when you change the channel. This is actually logical, since ARS defines a certain repeater offset and a certain set of repeater channels (band-plan). Any changes that violate these ARS settings are "reset" when changing channel. This is especially confusing in Europe, where the 70CM repeater band-plan differs per country and therefore the "pre-programmed" repeater band-plan often is not correct.

The solution: knowing this "strategy" behind ARS operation makes figuring out a solution very simple: just disable ARS (most likely on 70CM only). Then set one of the VFOs into the 70CM repeater band and enable repeater shift. YES: repeater shift setting will be stored with 70CM VFO setting and will remain active when changing channels. Such a channel can be stored into memory and repeater shift and offset will be stored with it. (Note that the repeater-shift on/off setting is tied to the VFO and band, just as it is with other settings like APO)

So, it's not a firmware bug, it's a feature - it's meant to be like this.

RF Exposure

Because the antenna is so close to the occupants of the vehicle with a mobile rig, some owners have expressed concern about whether or not the installation of the ATAS100 would comply with the FCC's guidelines on RF exposure. I had my ATAS mounted on

the corner of the hood which puts it about as close as possible to the driver. Here are the results of my RF field strength measurements using a Haladay HI3004 RF field strength meter when running a 100W FM signal as measured in the front seat near the driver's head:

Band	Field strength
10M	8 V/m
12M	20 V/m
15M	15 V/m
17M	15 V/m
20M	12 V/m
40M	16 V/m

Outside the vehicle, the field strength was about 30V/m when measured 2M horizontally from the antenna.

The FM signal was about twice the strength of a typical SSB signal since it puts out 100W at 100% duty cycle whereas SSB was about half of that. So the readings above are about 2 times higher than you would expect in normal HF operation.

The maximum exposure limit for a controlled environment is 61.4 V/m at 30-300Mhz and it rises as the frequency decreases according to the equation $1842/f$. For an uncontrolled exposure, the 30-300Mhz limit is 27.5 V/m and increases according to the equation $824/f$ as the frequency decreases where f is frequency in MHz

You can see from the readings that the fields inside the vehicle are well below the maximum allowable for a controlled environment such as a ham station, and even meet the more stringent limits for an uncontrolled environment. Combine that with the fact that the measurements were taken at 100W with 100% duty cycle, and you can see that this antenna arrangement is considered to be safe by FCC standards.

Transmit problems on 80/160M

Some FT100 owners find that they cannot transmit on any bands below 40M. This is almost always a result of having menu item 61 set to either ATAS-1 or ATAS-2. Since the ATAS autotuning antenna only works with bands 40M and above, the FT100 will refuse to transmit on 80 or 160M if you set it incorrectly. To get around this, you need to set that menu item to Tuner or 'OFF' if you're not using an ATAS antenna.

S-Meter Anomalies

Several owners have noticed that the S-meter on the FT100 tends to be somewhat stingy, particularly with FM repeaters. Many radios will give 60+dB readings on local FM repeaters whereas the FT100 will rarely register more than an S-9. Some responses to the FT100 mailing list indicated that the FT100 was correctly reporting signal strength whereas all the rigs that give readings such as 60+dB were overloading and going into limiting. If you would like to make the S-meter more sensitive, here are the procedures:

- First off, tune the radio to receive a strong signal from a local 2M FM repeater.

- Next, to get into the alignment mode, turn the radio off, now press the [A], [B], and [C] keys, and hold them in while you turn the radio on. Now press and hold the [FUNC] key, as you normally would to get into the Menu. You'll find that the Menu is now different.
- Rotate the selector knob until you find "F-07 [S FULL SCALE]" on the display. Make a note of the current setting of this item, so you can go back to it if you want to. Now adjust this item just like any other Menu item, by rotating the main dial, until you get a full scale reading on the S-meter.
- There also is an adjustment of the 144 MHz RF Gain (F-01) and the 144 MHz IF Gain (F-05). Perhaps a little adjustment to the RF Gain would help with the weak repeaters. Whatever you do, make a note of the original settings of these items. Adding too much front end gain can degrade the intermodulation performance of the receiver section. Also, if you change the RF or IF Gain, the S-meter indication will change, too.
- Press the [FUNC] key to exit the alignment mode.

If you have the equipment for it, you can more accurately adjust the s-meter by injecting a 14.200 MHz signal in USB mode into the antenna at +95dbmicroVolt and adjust F07 to read S9+60dB. You could also adjust it for an S9 reading on 40 Meters using 50 microvolts rms for S9, then "re-calibrate" the S meter mentally by remembering that above S5 the "S reading" is one S unit higher than actual, and also that S9+20dB is actually S9+15dB, S9+40 is S9+25 and S9+60 is S9+35.

There is only a single adjustment for the S meter which amounts to a DC offset. (It's NOT a scalar!) All you can do is shove the entire curve one way or the other. Most simple RSL indication circuits at least use a DC offset along with a DC gain setting. The latter allows you to set the steepness of the indicated RSL (receive signal level) function. The whole business is about proper interpretation of either a detector output or the AGC voltage. The FT-100D uses the AGC voltage to generate the indicated RSL. But they only included one control (DC offset) to you're really limited in terms of setting the accuracy of it.

Probably the best thing to do is to calibrate it on your favorite band for the standard 50 microvolts RMS (single sinusoid) for S9 and perhaps characterize your "indicated RSL versus actual RSL" so at least you know how to translate what the meter is indicating.

FT100D CW signal. Assume first segment is S2 based on relationship to segment which corresponds to S9.

Segments	7.2 MHz setting 205		With S9 set for -73 dBm		
	Display readout	Equivalent standard level (dBm)	Actual level in dbm	Actual level in "S" units	Display error
1	S2	-115	-102	S4	2 S units low
2	S3	-109	-101	S4	1 S unit low
3	S4	-103	-99	S5	1 S unit low
4	S5	-97	-98	S5	0
5	S6	-91	-96	S5	1 S unit high

6	S7	-85	-92	S6	1 S unit high
7	S8	-79	-85	S7	1 S unit high
8	S9	-73	-73	S9	0
9	S9+20dB	-53	-60	S9+13dB	7 dB high
10	S9+40dB	-33	-47	S9+26dB	14 dB high
11	S9+60dB	-13	-38	S9+35dB	25 dB high

S Meter accuracy

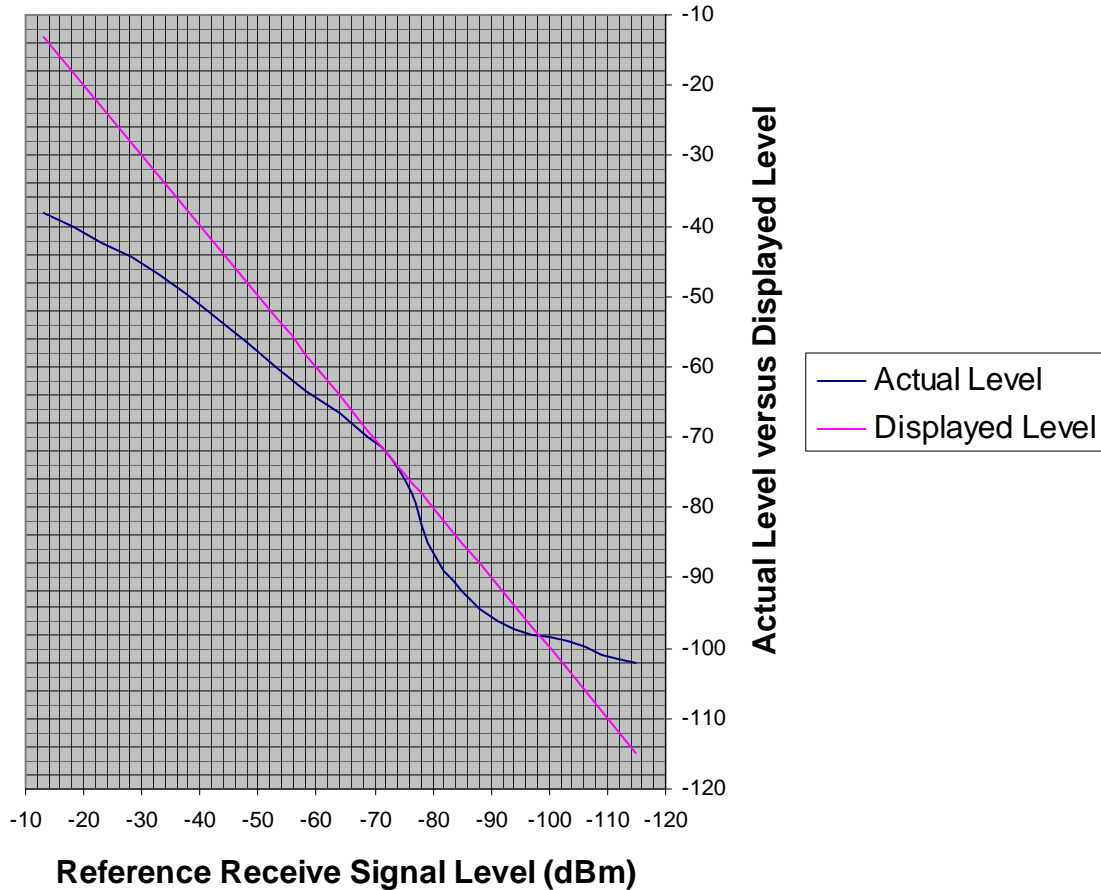

Satellite Operations

Although the FT100 is not designed for use with satellites, several owners have reported moderate success in working satellites with it, namely AO27, RS13, FO20/29, SO35, UO14 and even AO10. To work a satellite, the rig must be put in split mode with the uplink and downlink frequencies set appropriately. If you want to store a satellite settings in memory, you can use the DUP memories which are specifically designed to hold split frequencies. Working a linear transponder satellite in half duplex mode is not easy. You should have some experience in using satellites with rigs that have been designed for satellite operations such as the FT847.

FT100-SuperControl (<http://www.supercontrol.de>) now offers a special satellite mode, that can automatically correct the transceiver with Doppler shift data. The program supports the NOVA and Satscape satellite tracking programs which are used to get the needed range rate data of the desired satellites. Both transceivers VFOs can be automatically updated with the Doppler corrected frequency. And if this is not enough, there is a possibility to turn on additional realtime VFOs which can display the final frequency for optional transverter devices. Of course these final frequencies can also be used for the Doppler shift calculation, so it would be perfect for AO-40.

Separation kit (YSK100)

The separation kit is intended to allow the display/user interface portion of the radio to be physically separated from the chassis of the radio to facilitate installation in confined spaces. There are three cables included with the kit. One cable connects the front panel of the radio to the radio chassis. Another cable is an extension for the microphone and the third is an extension for the external speaker. There is a convenience to having three separate cables because it gives you more flexibility in mounting the display, microphone, and external speaker. There is also a plastic bracket to hold the display. It has a quick release feature similar to the radio chassis, but is not as convenient to use because the latch is harder to reach and to actuate. The price of the kit is US\$79.95.

Serial Numbers

Yaesu appears to use the following format for serial numbers on their amateur products:

Year of manufacture-Month of manufacture-Production Run-Individual Unit number

Example: 9D051234 = 1999, February (second month, or "D"), Production Run 05, unit #1234 in this run.

(Apparently Yaesu does not use the letters A or B as a letter in the second position, hence the first month, January, would be a 'C', February is a 'D', etc..)

Some members have reported that they are receiving models beginning with 9D at late as February, 2000 while others are getting units with serial numbers beginning with 9I. It is unlikely that the 9D units are factory refurbished but rather units that had been accumulating waiting to be updated to the latest revision level and sold as new. Refurbished products are required by law to be marked as such.

Sidetone/Beep Volume Adjustment

The sidetone/beep volume can be adjusted using VR1004 (labeled VR04 on the board). It is located under the top cover adjacent to the speaker connection. Be very careful as this pot is very small and can easily be damaged.

Squelch settings for FM and SSB

As shipped, the squelch threshold on the FT100 is the same for FM and SSB. As you change from 144 Mhz FM operations to HF SSB operation it's preferable to have the squelch open up in SSB mode and then close when going back to FM mode without having to change the SQL/RF control all the time.

This can be accomplished by changing Menu F08 (SSB SQL) in the secondary menus. For example, set the F-menu F08 value from 003 to around 050 to get the desired squelch behavior.

Storing memories remotely

There are no programs currently available to store the FT100 memory settings remotely because Yaesu did not leave any provisions in the rig for uploading or downloading memory locations. There was a rumor that RT systems was working on a version of ADMS software to provide this capability but they have confirmed that this is not true. The FT100 has more than 300 memory locations and if you intend to fill them all up, be aware if you ever reset the radio, they will be lost.

There are also no provisions for labeling the memory locations with alpha-numeric labels, most likely because the main display uses 7-segment characters for the main frequency which are only appropriate for displaying numbers, not alpha characters.

It's probably best to think of the FT100 as a mobile HF rig with UHF/VHF capabilities. It can't compete with all the features you would find on a radio designed specifically for VHF/UHF operation.

SWR meter interpretation

There is no mention in the FT100 manual how to interpret the SWR bar graph on the FT100 display. The following measurements were made on the 10M band by moving the antenna very carefully to get the appropriate number of SWR bars on the FT100 and then disconnecting the radio and measuring the SWR of the ATAS100 with an MFJ259 SWR Analyzer. The HighSWR icon came on when an SWR with 7 or 8 bars was showing.

Number of FT-100 SWR bars	MFJ 259 SWR reading
1	1.5
2	1.7
3	1.9
4	2.1
5	2.4
6	2.6
7	2.8
8	3.0

UP/DOWN band switching

The UP/DOWN keys are intended to move up and down through the amateur bands according to the manual. However, several users have noticed that the radio will put additional non-amateur bands in the list if the radio is tuned to them while operating in VFO mode. Examples of non-amateur bands that can end up in the list include the NOAA weather station (165 MHz), and Citizen's Band (27 MHz). The FT100 will insert one extra band on the HF side and one on the VHF/UHF side of the radio. It is not clear how one removes the non-amateur bands from the list other than resetting the radio.

V/U MESFET pre-amp adjustment

When the FT-100 is in receive mode on VHF or UHF, now and then the squelch may 'splatter'. To clarify, what happens is this:

- The S-meter indicates brief peaks from S1 to S9++ (like there's a lot of static or irregular spark-induced QRM)
- The green 'busy' LED goes on and off
- Lots of 'static-like' crackling sounds come from the speaker

This all *looks* like there's just a lot of QRM'ish noise on the frequency, but when you turn the squelch threshold knob counterclockwise to open up the squelch, the whole phenomenon disappears. If there really was static or QRM being received, this should not happen. Also, if you turn the squelch threshold knob fully clockwise, the speaker remains muted but the 'busy' LED and the S-meter still indicate irregular, intermittent and brief signal peaks.

This is caused by spurious responses in the V/U MesFet pre-amps, the SGM2016s. The cure is to go into the hidden F menus, hold in the ABC keys and power the radio on and then press the function key and rotate the dial until you come to the F menus and the first one will be F01 and once you find F01 the VHF receivers RF gain, lower the DAC value to **115** and then go to F02, the UHF receivers RF gain, and lower its DAC value to **106**. You may want to note the original DAC values and write them down just for reference. Some users have had this problem and lowering the DAC value for each pre-amp cured it.

IMD tests with the original values and the lowered values show no difference in sensitivity, nor any change in 3rd order intercept point. There is however a marked reduction in spurious response.

Apparently the radios are set up with a generic factory programmed DAC value and not by actually measuring intercept points or by looking around the receiver range for spurious responses. The DAC values have nothing to do directly with controlling the gain such as controlling an attenuator value, all the DAC does is set the bias to the MESFETs and they are borderline unstable at the bias setting with the factory DAC values.

Yaesu Contacts

Here is the new contact information for Yaesu as of April, 2002:

VERTEX STANDARD US HEADQUARTERS

10900 Walker Street

Cypress, CA 90630

Phone: 714-827-7600

Fax: 714-827-8100

EMAIL ADDRESSES:

Amateur Sales: amateursales@vxstdusa.com

Amateur Tech Support: amateurtech@vxstdusa.com

Amateur Customer Service: customerservice@vxstdusa.com

Parts: yaesuparts@vxstdusa.com

International contact information: <http://www.yaesu.com/amateur/contact.html>.

Frequency list

Freq.	Mode	Memory	Description

