

FT-747GX



**OPERATING
MANUAL**

FT-747GX

YAESU MUSEN CO., LTD.
C.P.O. BOX 1500
TOKYO, JAPAN

FT-747GX

HF ALL MODE
COMPUTER AIDED TRANSCEIVER



The FT-747GX is a compact SSB/CW/AM and (optionally) FM transceiver for the amateur radio service, providing 100 watts of PEP transmitter power output on all hf amateur bands, and general coverage reception from 100 kHz to 30 MHz.

Convenient features include operator selectable mode-dependent tuning steps, twenty memory channels which store mode, simplex or split frequencies and scanning status, auto-resume scanning of selectable memories, a clarifier, and a CAT (Computer Aided Transceiver) System for user programming and more advanced control by an external computer. Wideband (6 kHz) AM and narrowband (500 Hz) CW IF filters are included as standard. A switchable 20dB receiver attenuator and noise blanker are provided to optimize reception under varying conditions.

The transmitter power amplifier is enclosed in its own diecast aluminum heatsink chamber inside the transceiver, with forced-air cooling by an internal fan allowing full power FM and AFSK operation when used with a heavy duty power supply. Optional accessories include your choice of the MD-1B8 Desktop Scanning Microphone or the MH-1B8 Handy Scanning Microphone, and the microprocessor controlled FC-757AT or FC-1000 Automatic Antenna Tuners or FL-7000 500-watt Automatic Solid State Linear Amplifier.

Special power supplies for the FT-747GX include the FP-757HD Heavy Duty Series-Regulator Power Supply with forced-air cooling and automatic thermal fan control, or the FP-700 standard power supply for low power and light-duty applications. Both power supplies can be wired for 100/110/117/200/220 or 234 VAC.

Emission types

LSB, USB (J3E); CW (A1A); AM (A3E)
and optionally FM (F3E)

Power output

SSB, CW & FM*: 100W PEP/DC,
AM: 25W Carrier

SSB Carrier suppression

better than 40dB below peak output

Unwanted sideband suppression (SSB)

Clarifier range

±9.975 kHz

Sensitivity (for 10dB S+N/N, exc FM)

	<u>0.5-1.5MHz</u>	<u>>1.5MHz</u>
SSB/CW:	0.5uV	0.25uV
AM:	2uV	1.0uV
FM*:	0.7uV for 12dB SINAD (above 28MHz)	

Squelch sensitivity

SSB/CW/AM: 2.0uV above 1.5 MHz,
4.0uV within 0.5-1.5 MHz

Spurious radiation

Harmonic: better than -50dB
Non-Harmonic: better than -40dB

Audio response

less than -6dB from 400 to 2600Hz

3rd order intermodulation distortion

Intermediate frequencies

47.055MHz, 8.215MHz, 455kHz(FM-only*)

Image rejection

better than 70dB within 1.5-30MHz

IF rejection

better than 60dB within 1.5-30MHz

Modulation systems

SSB/CW: active balanced modulator
AM: early stage (low level)
FM*: variable reactance

Selectivity (-6/-60dB)

SSB, CW(W), AM(N): 2.2/5 kHz
CW(N): 500 Hz/1.8 kHz
AM(W): 6/14 kHz; FM(-6/-50dB)*: 8/19kHz

Maximum FM* deviation

± 2.5 kHz

Maximum audio power output

at least 1.5W into 8 ohms w/10% THD

* FM operation requires optional unit.

Antenna impedance (nominal)
50 ohms, unbalanced

Supply voltage
13.5 V DC \pm 10% (neg. ground)

FP-757HD	Heavy Duty Power Supply
FP-700	Standard Duty Power Supply
FC-757AT	Automatic Antenna Tuner (100W)
FL-7000	500W Automatic Linear Amplifier
FAS-1-4R	Remote Antenna Selector (for use with FC-757AT or FL-7000)

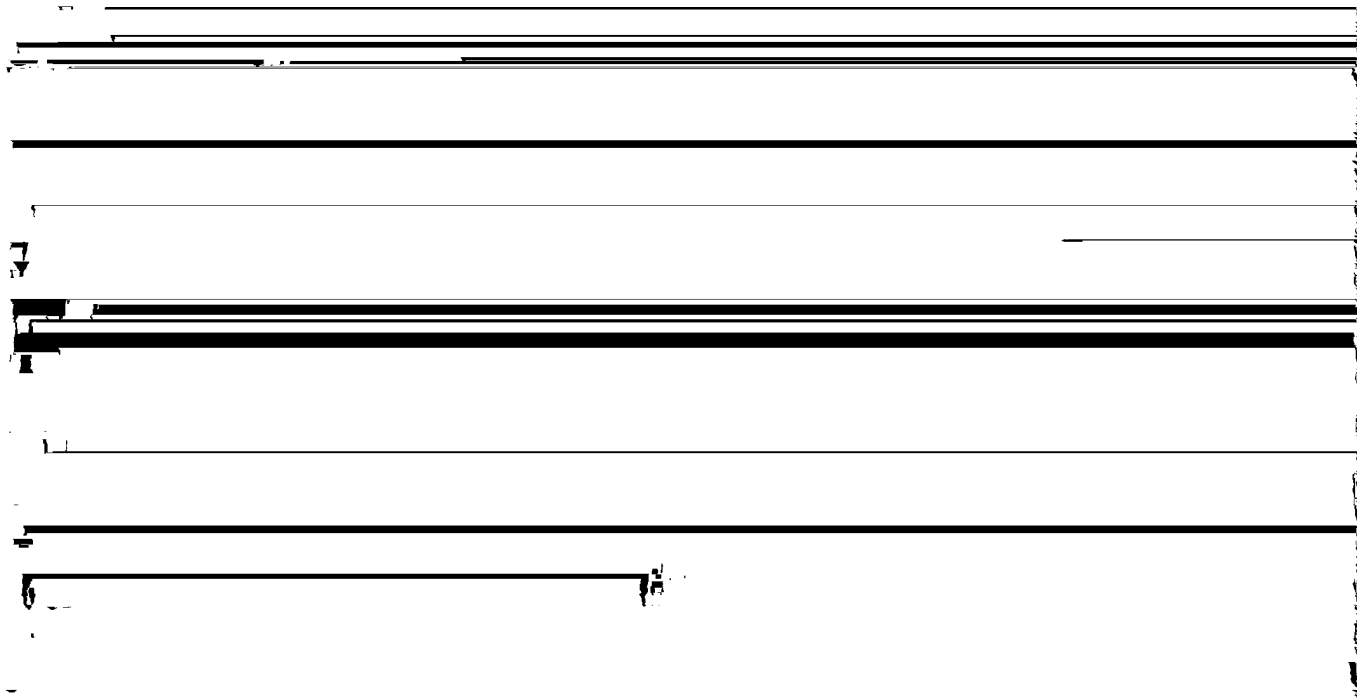

19A (@100W output)

SP-767P	Base Loudspeaker w/Phone Patch
SP-55	Mobile Loudspeaker

Dimensions (WHD)
238 x 93 x 238mm (without knobs)

Weight (approx)
3.3 kg (7.25 lb)

Specifications may be subject to change without notice or obligation.

On and Off frequency and mode data in the memories and vfos is not affected by this switch (or by whether power is connected to the transceiver), since the data is retained by an internal lithium battery.

(2) MICrophone

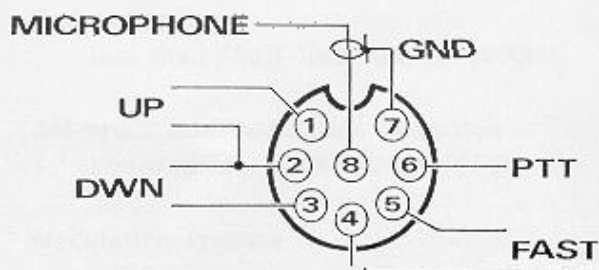

This 8-pin connector accepts the plug of the MD-1B8 Desktop Mic or MH-1B8 Hand Mic. Scanning control lines from these microphones allow pushbutton fast and slow tuning and scanning from the microphone.

jack. Stereo headphones with a 3-conductor plug reproduce audio in both ears, as with monaural headphones with a 2-conductor plug. Inserting a plug into this jack disables the internal or external loudspeaker.

(4) CLAR

Press this button while receiving to activate clarifier operation. The tuning knob then tunes the receiver without affecting the transmit frequency. Press this button again to turn off the clarifier.

(5) D LOCK

This button disables the tuning knob and microphone tuning buttons to prevent accidental frequency changes. "LOCK" is shown on the display when active. Press this button again to re-enable tuning.

THE SPLIT POWER CONTROL adjusts the carrier power output level for CW, AM and FM transmission. This control is disabled during SSB transmission.

operation between the two rigs, and press it again to cancel split operation.

receiver. The indicator on the button glows green when the attenuator is on.

operating frequency with 100 Hz resolution. The number of the active (or last-used) memory (00 thru 19) is displayed to the right of the frequency (with 'CH' above).

Activates the noise blanker for SSB, CW and AM reception.

(17) ON AIR Indicator Lamp

This lamp glows red when transmitting.

(15) MOX Button

Manually switches the transmitter on and off. This button MUST be in the OUT position to receive.

(18) Meter

The meter shows relative signal strength in S-units on the uppermost scale when receiving, and relative power output (PO), when transmitting.

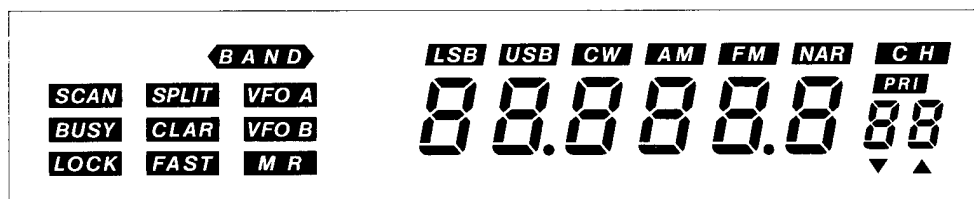

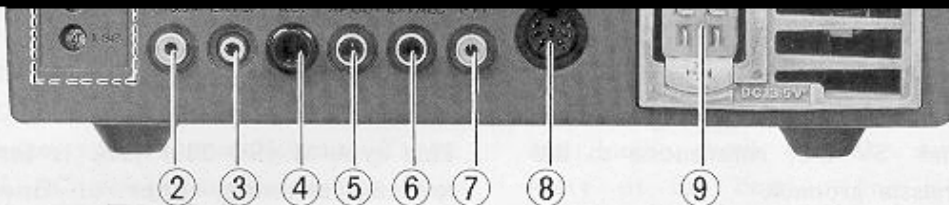

(1) CAR ADJ Potentiometers

These (recessed) trimmer capacitors set the IF passband center offset from the carrier. They are aligned at the factory and should not be adjusted without proper test equipment. The procedure is described in the "FT-747GX Technical Supplement".

(2) +13.5V

This phono jack provides 13.5V DC at up to 200 mA for powering accessories. The center contact is positive.

Note: Repairs to damage caused by exceeding the current capabilities of the accessory DC jack may not be covered by the warranty.

(3) EXT SP (External Speaker)

This 1/8-inch 2-conductor mini phone jack provides amplified receiver output to drive an external 4- to 16-ohm loudspeaker.

(4) KEY

This 1/4-inch 2-conductor phone jack accepts a CW key or external electronic keyer. Open circuit voltage is +13V DC and closed circuit current is 0.7 to 1 mA.

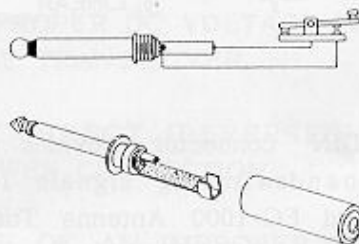

(7) PTT Jack

This phono jack provides access to the PTT line, for external receive/transmit switching. Connecting the inner contact to the outer contact (chassis ground) activates the trans-

unbalanced. Use only a properly mating type-M (PL-259) plug and 50- or 52-ohm coaxial cable.

(11) GND

closed circuit current is about 1 mA.

this terminal to a good earth ground through the shortest path possible.

(8) BAND DATA

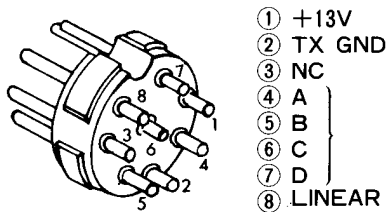

This 8-pin DIN connector provides parallel TTL-level bandswitching signals for the FC-757AT and FC-1000 Antenna Tuners or the FL-7000 Linear Amplifier.

(12) CAT

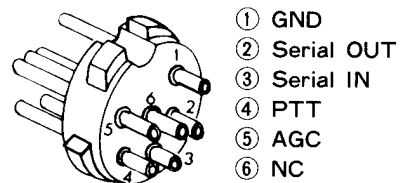

This 6-pin DIN jack provides access to the serial data lines from the microcomputer and A/D converter, for control of the transceiver from an external computer. See the CAT section of this manual for details.

3. INSTALLATION

Preliminary Inspection

When you open the packing carton, inspect the transceiver carefully for any signs of damage. Check that all exposed controls and switches move freely, and that the cabinet has no dents or scratches. If you notice any damage, document it completely and contact the shipping company immediately. Save the packing materials for possible future use.

Base Station Installation

The FT-747GX requires a power source of 12 to 15 volts DC, capable of up to 20 amperes peak. For base station installations, Yaesu offers several AC power supplies which may be used with AC line voltages of 100, 110, 117, 200, 220 or 234 VAC. However, before connecting any power supply to the transceiver or AC line, make sure that the supply is properly wired for the local line voltage, and that the correct fuse is installed.



FP-757HD

The FP-757HD is a heavy duty series regulated power supply capable of full power transmissions for up to 30 minutes at a time (50% duty cycle is recommended for continuous operation). Forced-air cooling is provided over an extra large internal heatsink. The FP-757HD, equipped with a power transformer, is designed for use with AC line voltages of 100, 110, 117, 200, 220 or 234 VAC. Power transformer primary connections for the different line voltages are shown at the right.

The FP-700 power series regulated supply may be used for light duty operation (CW, SSB or reduced power AM or FM). AC voltages, fuse requirements and power transformer wiring are the same as for the FP-757HD described above and shown in the diagram below, but the plastic sleeve on the supply DC cable must be cut to allow connection to the speaker in the power supply.

NEVER CONNECT AC, OR DC ABOVE 15V, DIRECTLY TO THE FT-747GX.

Make certain that the POWER switch on the front panel of the FT-747GX is OFF (out) before connecting power to the transceiver, and double check to make sure that the polarity of the connections is correct before switching the transceiver on.

Power Transformer Primary Connections

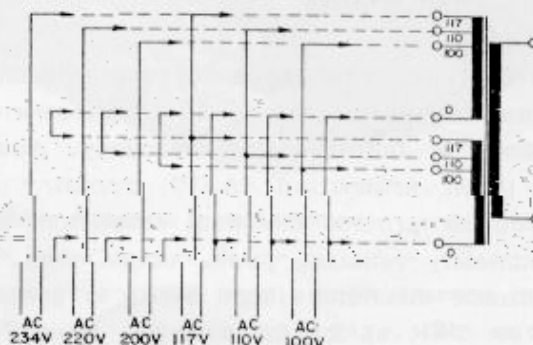

NOTICE

THE FOLLOWING ABUSES MAY CAUSE DAMAGE TO THE EQUIPMENT WHICH IS NOT COVERED UNDER WARRANTY:

- (1) CONNECTION OF AC VOLTAGE OR IMPROPER DC VOLTAGE DIRECTLY TO THE TRANSCEIVER.
- (2) INCORRECT (REVERSED) POLARITY POWER CONNECTION.
- (3) USE OF AN IMPROPER FUSE IN THE POWER SUPPLY.

Use 50-ohm coaxial cable with a proper

replacement lamp fuses, ask your local Yaesu

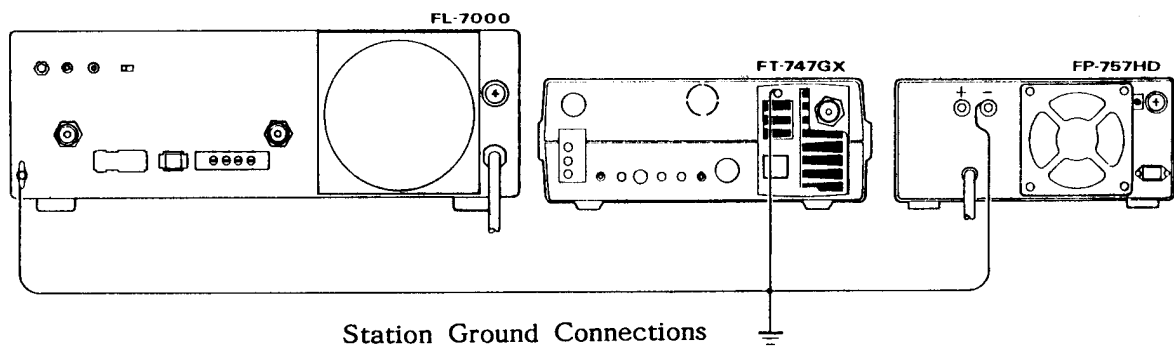

Station Ground Connections

terminals with the engine running fast enough to show a charge. If above 15 volts, the automobile voltage regulator must be adjusted to reduce the charging voltage before proceeding.

- (3) Make sure the POWER switch on the transceiver is OFF and connect the DC cable to the transceiver. The plug pin connections are shown on page 8.

mation on the previous page. An antenna tuner such as the FC-757AT or FC-1000 is particularly desirable in a mobile station, where the short antenna elements have very narrow bandwidth. Make sure that the shield of the antenna coax is firmly grounded to the car body at the antenna feedpoint.

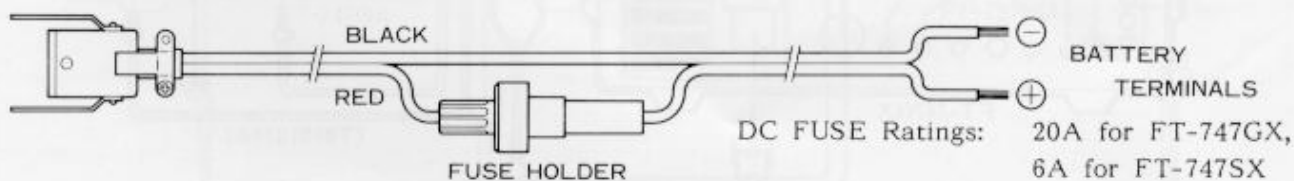

Linear Amplifiers

The FT-747GX includes a high voltage (150V) transistor switch capable of handling up to 1.5 amperes DC, to control transmit/receive switching of a linear amplifier via pin 6 of the BAND DATA jack. However, make certain that the t/r switching requirements of your linear amplifier do not exceed these limits, and that the linear switching voltage is +DC, and not -DC or AC. Yaesu offers the optional FRB-757 Relay Box for t/r switching of linears that require negative or AC switching, or higher voltage or current switching. The FRB-757 installs between the relay jack on the amplifier and the PTT jack on the transceiver, and is capable of switching up to 250V AC or DC, at up to 2.5A.

If you are installing the FT-747GX with the FL-7000 Auto-Tune Linear Amplifier or the FC-757AT Automatic Antenna Tuner, set internal switch S02 to position 1 as described on page 25.

The memories and vfos of the FT-747GX are retained by an internal lithium cell for five years or longer. The backup circuit is turned on at the factory, so it is not necessary to do anything unless the battery runs down, in which case memories will be lost when the transceiver is turned off and power removed. If this occurs, contact your Yaesu dealer for replacement of the lithium battery.

If you want to clear all memories, or if you plan to store the transceiver for a long time without power connected, disable the backup system by moving the backup switch (indicated on page 22) to its alternate position. If clearing memories, do this with the power disconnected, wait 30 seconds, and then set the switch back ON before restoring power.

INTERCONNECTION DIAGRAMS

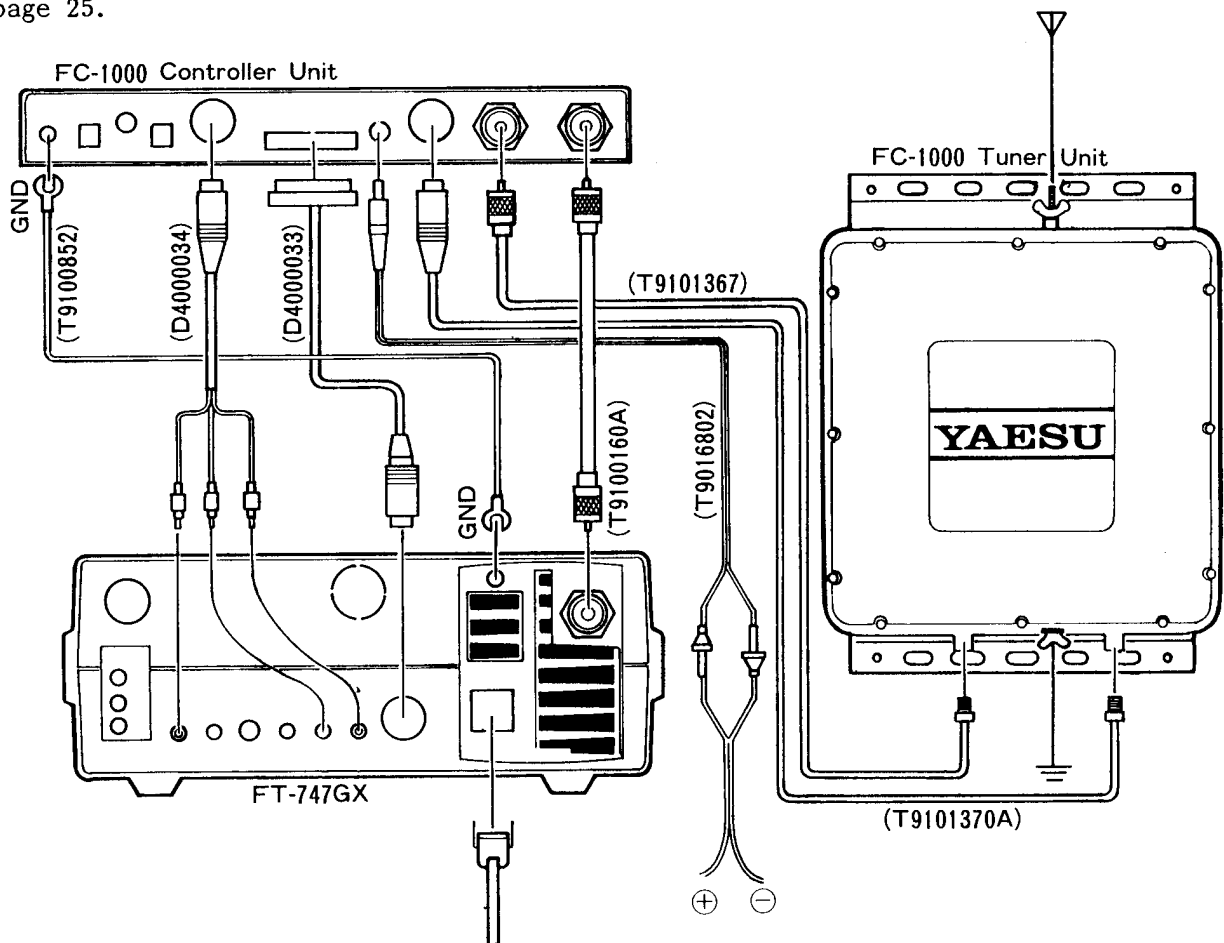

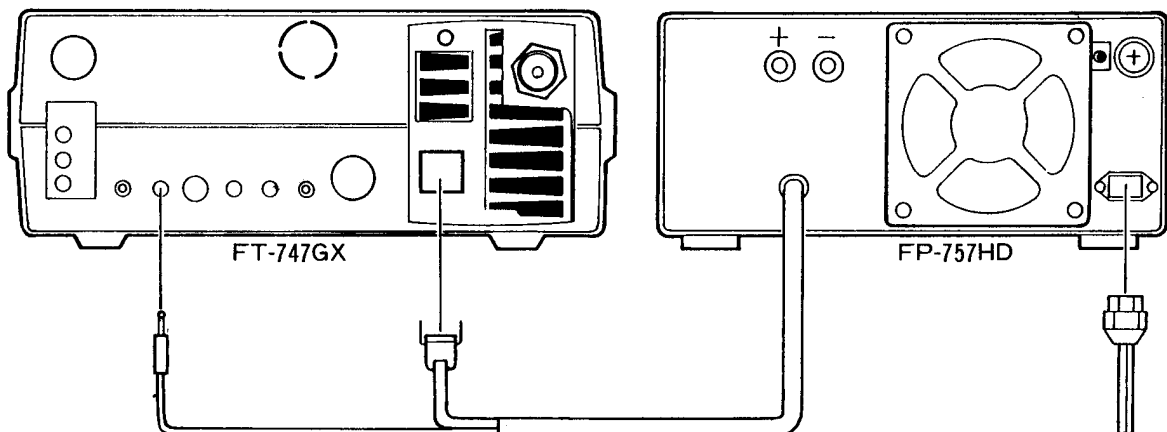
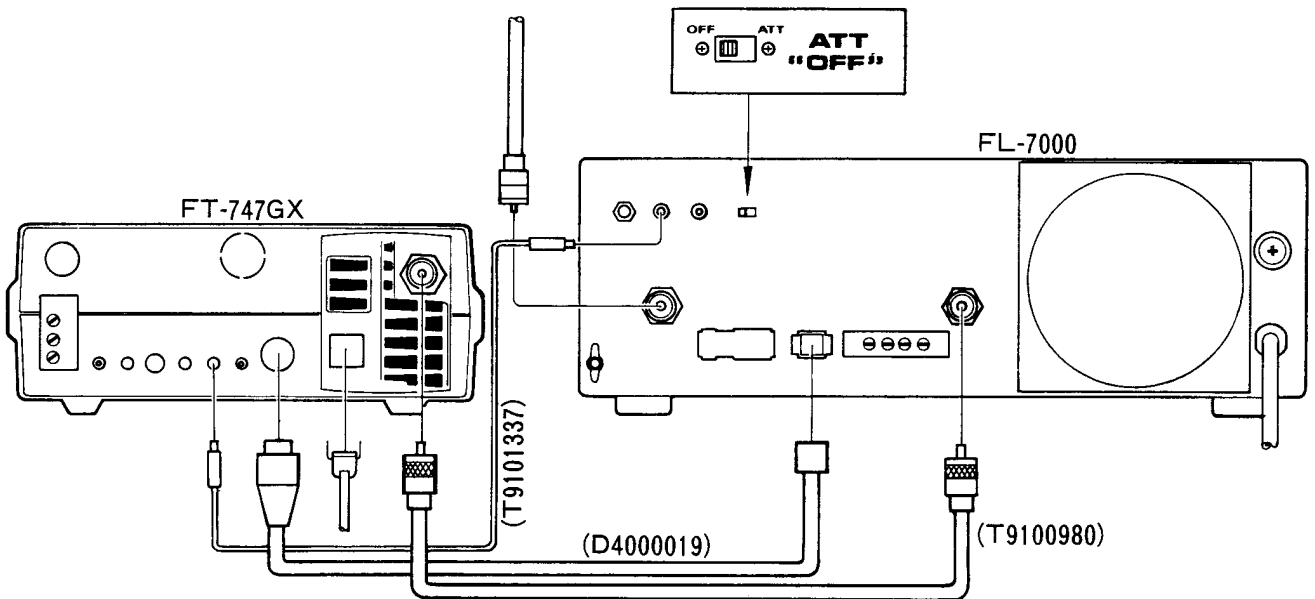
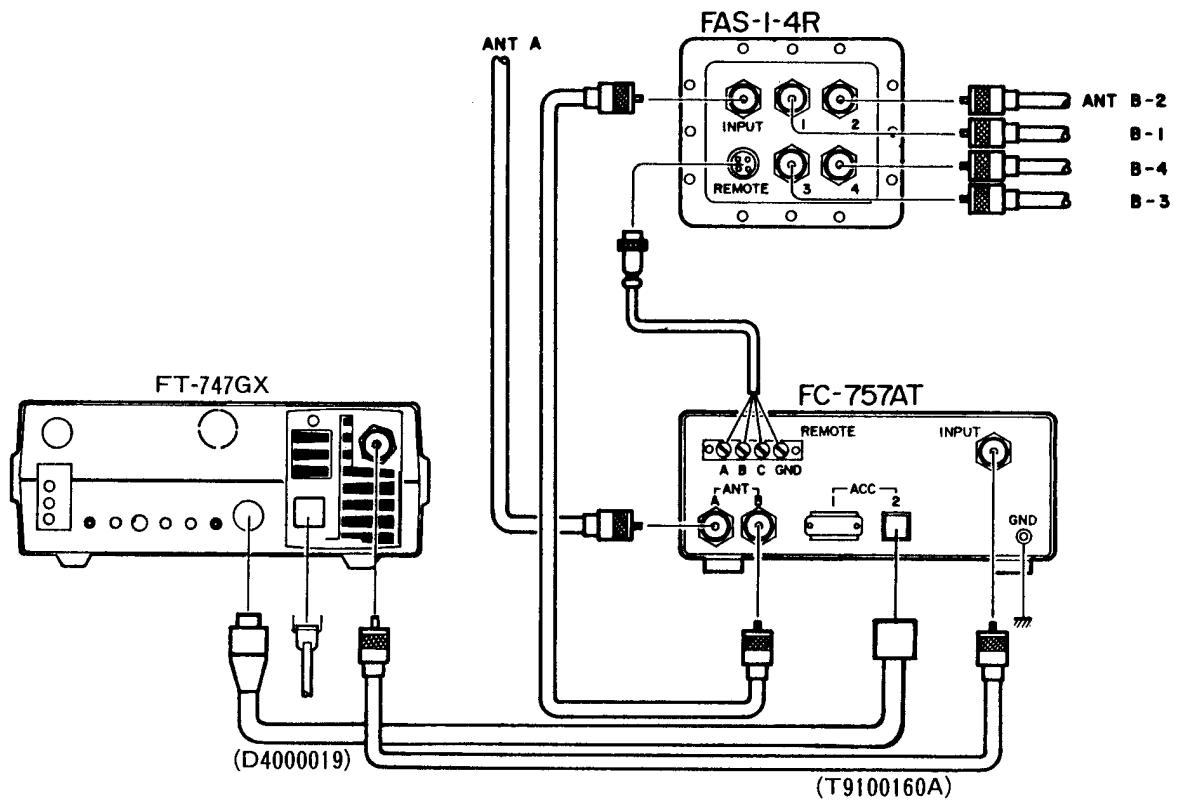

Connect a microphone, if desired, to the MIC jack. For CW operation, connect a CW key (or external keyer) as shown on page 7 to the KEY jack on the rear panel.

The 500 kHz BAND steps can be used only when tuning a vfo. You can use them to select any 500 kHz range for reception, but transmission is limited to the 500 kHz segments containing amateur bands.

Reset the POWER switch and the BAND buttons to the undepressed position. Set the knobs all fully counterclockwise.

Confirm that the MOX button is OFF (undepressed (out) position), and then switch on the power supply, followed by the transceiver POWER switch. The meter and display will light, with the display indicating the default (memory clear) state: VFO A, LSB, 7.000.0.

When selecting the operating band, you can loop around from the low edge to the high edge of the transceiver frequency range and vice-versa, but this automatically resets the operating frequency to the nearest 500 kHz step. For example, if you tune to 110.5 kHz and then press the BAND button and tune (one step) lower (tuning knob counterclockwise one click), the display will change to

Band Selection

Press the BAND button and immediately turn the tuning knob (or press the microphone DWN/UP keys) to tune in 500 kHz steps ("BAND" appears blinking on the display). Press the BAND button a second time (while "BAND" is still blinking) to set the new displayed frequency in the vfo.

Pressing the BAND button the first time starts a 5-second timer, which is reset whenever the tuning knob is moved (or mic key pressed). However, if you do nothing for five seconds, "BAND" will disappear and the display will return to its original frequency.

29.500.0. Then, if you turn the knob back one step, the display will show 500.0. If you do not tune through the frequency limits (100 kHz and 30 MHz) during band changing, the digits under 500 kHz are preserved.

Mode Selection

From the LSB mode, just press the right side of the MODE button (repeatedly, if necessary) to select the desired operating mode. From other modes, you may need to press the other side of the MODE button until the mode you want is displayed.

Because the tuning steps are larger in AM and FM modes than in CW and SSB, least significant frequency digits are zeroed when

on page 5. In CW and SSB modes the fine steps are 25 Hz, so only every fourth step will change the displayed frequency.

Note: if you press the BAND button while "FAST" tuning is selected, tuning will be in 5 MHz giant steps!

The FAST button on the microphone greatly facilitates vfo tuning with the tuning knob: operate the tuning knob with one hand while operating the FAST button on the mic with

performance in the presence of strong signals or high noise levels.

The attenuator may often be needed on frequencies below 10 MHz, particularly if you are using a large antenna or your station is in a noisy environment (city).

Noise Blanker

Pulse-type noise, either short duration types such as from ignition systems and electric

your other hand. This allows quick searching for activity (with the FAST function on), and then easy fine tuning when the FAST function is turned off. Of course you can also tune up or down using the UP or DWN keys on the microphone.

NOTE: The tuning knob and microphone keys are deactivated when the D LOCK (dial lock) function is active. When the dial is locked, 'LOCK' appears on the display. Press the D LOCK button to toggle the lock on and off.

SSB Reception

The ATT and NB switches and the SQL control are provided to reduce or eliminate the various types of noise and interference that can obstruct comfortable reception. Oper-

processors and switches, or long duration over-the-horizon radar ("woodpecker") signals, can be reduced or removed by pressing the NB button. However, when noise blanking is not required the NB button should be off (out), to minimize distortion introduced by the blanking process.

Squelch (All Mode)

When waiting for a scheduled call on a fairly uncrowded band the squelch can be activated to silence the receiver until the call. Just tune to the scheduled frequency and turn the SQL control clockwise until the receiver is quiet. Two other things happen when the squelch is closed: the S-meter reading drops to zero (if it wasn't already), and "BUSY" disappears from the display.

described previously before adjusting the SQL control, as the squelch threshold is affected by the ATT setting.

due to a nearby signal which can sound about twice the audio bandwidth (fidelity) of the AM narrow mode.

To use ECSS, first tune in the station using

CW Reception

In addition to the ATT, NB and SQL controls described for SSB, the FT-747GX CW NAR (narrow) mode provides a 500 Hz IF crystal filter to enhance reception. Use the CW (wide) mode to tune in the desired signal for about a 700 Hz pitch, and then press the NAR switch.

The CW (wide) mode provides the same IF bandwidth as for SSB, allowing you to hear signals up to about 1 kHz away while tuning around the band. Noise and interference are

the AM mode (shortwave broadcasters generally transmit on precise multiples of 5 kHz), and then select either USB or LSB, whichever gives best reception. Now carefully fine tune for zero beat (most natural voice/music pitch), and push D LOCK so you don't lose the frequency.

Hint: Zero beating an AM signal in ECSS reception requires very precise setting of the tuning knob. Some practice with stronger signals first will make tuning the weak ones easier. Coarse tuning is useless for ECSS.

greater than for CW NAR, but the wider bandwidth makes tuning easier.

Hint: when you make contact with another station on CW, press the CLAR button after he responds to you if you need to retune, then press the D LOCK button to avoid accidental frequency change, and finally the NAR button to select the narrow filter.

AM Reception

The FT-747GX includes a 6 kHz (wide AM) filter for good fidelity during reception of mediumwave and shortwave AM broadcasts. Pressing the NAR switch reduces the band-

when receiving AM signals. When in AM or ECSS mode, the noise blanker should be off unless it is really needed. Its effectiveness will vary depending on the signal strength of the received signal and those on adjacent channels; being most effective when the signals are weak and noise pulses are strong.

FM Reception

The FT-747GX requires the optional FM Unit (circuit board) for FM operation.

The MIC gain control and noise blanker (NB) switch are disabled for FM operation. However, the ATT and SQL settings are especially important. For weak signal work, set the

by the AF gain control, and using this jack disables the internal speaker. Select either the LSB or USB mode for operation, and see your TU or TNC manual for further details.

TRANSMITTER OPERATION

The solid state transmitter in the FT-747GX requires no adjustment other than setting the desired output level. The maximum power output is determined by the mode and the capability of the power supply (in AM, FM and RTTY, power should be restricted to avoid overheating the power supply if you plan to make long transmissions). Also, there are certain precautions to be observed at all times when transmitting to avoid possible damage to the transceiver, and to assure a clean signal.

Never transmit without having a dummy load or antenna tuned to the operating frequency connected to the transceiver (or linear amplifier, if used). If you have doubts about the suitability of your antenna on a certain frequency, check the SWR (Standing Wave Ratio) first using an external SWR meter.

When using a light- or medium duty power supply such as the FP-700, do not attempt to transmit FM, AM or RTTY at full output power. Although the transceiver is capable of this, some power supplies are not, and they may rapidly overheat and be seriously damaged. In any mode, feel the supply occasionally and reduce power or stop transmitting for a while if it feels hot.

Never start transmitting (except into a dummy load) without first listening for a few minutes to make sure the frequency is clear, and then transmit your callsign. This prevents accidental interference to other stations.

SSB Transmission

With a microphone connected to the MIC jack on the front panel, preset the MIC gain control to 12 o'clock, tune to a valid transmitting frequency (in the amateur bands), and select the LSB mode (on bands below 10 MHz) or the USB mode.

To activate the transmitter, close the PTT

clarifier. As long as you don't touch the tuning knob, pressing CLAR again returns you to the same (offset) receive frequency. When the contact is finished, remember to switch off the clarifier.

CW Transmission

The FT-747GX offers semi break-in operation for both simplex and split-frequency operation. Connect your key or external electronic keyer to the KEY jack on the rear panel, and select the CW mode. Close the key to activate the transmitter, and adjust the DRIVE control for the power output desired (100W output = "8" on the PO meter scale). After making contact with another station, reduce power with the DRIVE control as much as possible without losing contact.

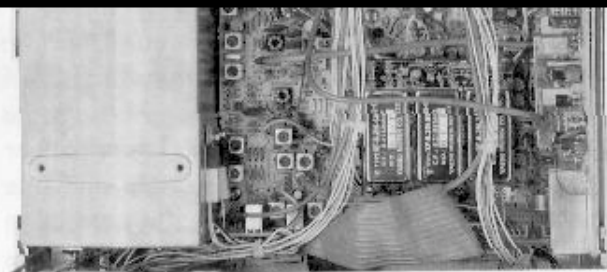

FM Transmission (requires optional Unit)

For FM transmission, just select the FM mode and close the PTT switch to transmit. The MIC gain control is disabled for FM, as the gain of the microphone amplifier is preset internally for ± 2.5 kHz deviation, and requires no further adjustment. RF power output is adjusted by the DRIVE control. For full power output (using the FP-757HD power supply), adjust the DRIVE so that the meter deflects to "8" on the PO scale. When contact is established, reduce the DRIVE.

subsequent damage to the supply.

Regardless of the power source or mode, we recommend reducing power from the maximum levels mentioned above whenever transmitting for more than 10 minutes, or if the ambient air temperature is very hot or the power supply feels hot.

AM Transmission

Because carrier power is only one fourth of the total PEP of an AM signal, it must be limited to 25 watts or less ("4" on the PO scale) when transmitting with the FT-747GX. When the power of the modulating sidebands is added to the carrier power, actual PEP output is 100 watts, although this does not show on the meter.

Transmission of narrowband FSK (RTTY, SSTV and Bell 103 HF packet) requires input of equal level audio tones (AFSK) at pin 8 of the MIC jack. Select LSB or USB mode.

The PTT jack on the rear panel may be used for external transmit/receive control. Of course manual transmit/receive control is also possible with the MOX button.

Note that the displayed frequency is the (suppressed) carrier frequency, so your actual transmitted MARK and SPACE frequencies will be displaced from the display by the audio frequencies of the input tones.

Use the MIC gain control to adjust power output: "8" on the PO scale indicates full power. Reduce output by turning the MIC gain counterclockwise while observing the PO

To adjust the FT-747GX for AM transmission;

- (1) Preset the MIC gain fully counterclockwise.
- (2) Make sure the frequency is clear, and then close the PTT switch on the microphone and advance the DRIVE for a meter deflection of "4" on the PO scale.
- (3) Speak into the microphone and advance the MIC gain control until slight movement of the meter occurs on voice peaks. PEP output is now 100 watts. Do not

As mentioned previously, the FT-747GX is capable of full power AFSK for limited periods when used with a heavy duty power supply. Restrict transmissions to 30 minutes with the FP-757HD. If using the FP-700, restrict power output to "4" on the PO scale. If the air temperature is high or at high altitudes, cooling efficiency is decreased and so power output should be reduced accordingly. Also, it is a good practice to back off on the power whenever making a long transmission, and even then supply temperature should be closely monitored.

Twenty memory channels, numbered 00 through 19, are available for storing frequencies and modes after selection on the vfos. The two vfos, denoted VFO A and VFO B, each hold frequency and mode independently, so there are actually 22 memories altogether.

VFO A/B Selection

The current operating vfo is indicated by "VFO A" or "VFO B" displayed to the left of the frequency. To select the alternate vfo, press the left (VFO) side of the VFO/MR button while receiving on a vfo. The frequency and mode of the other vfo are retained until selected again (in the same way).

VFO/Memory Selection

The memory number is always indicated on the display to the right of the operating frequency. While receiving on a vfo, press

turn the tuning knob to select an unused memory channel (default data is 10.000 MHz LSB in all channels), or one you are willing to overwrite.

- (4) Press the VFO side of the VFO/MR button to return to the vfo.
- (5) Press the VFO-M button to write the data from the vfo to the memory (operation remains on the vfo).

Note that the VFO-M key overwrites (erases!) the previous memory contents. Steps (2), (3) and (4) are required only to select the memory channel that is to be written. If you already know that the selected memory is free to accept new data, these steps can be skipped.

Memory Recall

- (1) Press the right side of the VFO/MR button to recall memories: the display

the right (MR) side of the VFO/MR button to select operation on the displayed memory: "MR" is displayed to the left of the operating frequency during memory operation.

To return to vfo operation from a memory, just press the "VFO" side of the VFO/MR button: once for the last-used vfo, and again for the alternate vfo.

Memory Storage

This procedure allows storage of the vfo mode and frequency into a memory channel;

and mode indicators will change to the displayed memory's data.

- (2) While watching the memory number (beneath "CH" at the right side of the display), press the DWN and UP keys on the microphone or turn the tuning knob to select different memories.

The mode of a recalled memory may be changed temporarily by the MODE keys. When another memory or a vfo is selected, the temporary mode selection is cancelled (but see the next procedure).

- (1) Press the VFO side of the VFO/MR button, twice if necessary, to select the vfo you want to use. Note that its contents will be lost!
- (2) Press M-VFO to copy the memory data into the selected vfo.
- (3) Retune or change mode as desired.
- (4) Press VFO-M to restore the displayed vfo data back into the memory.

Notice that operation is left on the vfo, but you can press the MR side of the VFO/MR button to return to the (changed) memory.

Split Frequency Operation

The two vfos and the SPLIT key can be used to set up split frequency operation, which can then be stored in any memory (except memories 18 and 19) in the normal fashion.

- (1) Press the VFO side of the VFO/MR button, as necessary, to select VFO B (displayed at the left).
- (2) Tune to the desired transmit frequency (and mode, if different from receive).
- (3) Press the VFO side of VFO/MR again to select VFO A, and tune to the desired receive frequency and mode.

by following the Memory Storage procedure. However, note that if you press M-VFO to recall the split memory into the vfo, both vfos (A and B) will be overwritten.

SCANNING

When the squelch is adjusted to silence the receiver, some or all of the memories can be scanned automatically. Signals that are strong enough to open the squelch will cause scanner to pause for five seconds.

The ATT switch should be set for the desired sensitivity before adjusting the squelch, as it affects squelch sensitivity.

The DWN and UP buttons on the microphone are used to activate and deactivate the scanner. A small arrowhead appears on the display just beneath the memory number to indicate scanning direction.

To scan the memories:

- (1) Set the SQL control to the point where background noise is just silenced.
- (2) Press the MR side of the VFO/MR button, if necessary, to recall the memories.
- (3) Press the DWN or UP button on the microphone to start the scanner: "SCAN" is displayed blinking.

Now receiving is on VFO A, but when the PTT switch or key is closed, transmission is

channel having a signal strong enough to open the squelch, and will resume again if the signal drops out. If you notice that the

scanner is skipping some memories, see the next section: Selective Memory Scanning.

To stop scanning press the microphone DWN or UP buttons or the PTT switch momentarily.

Selective Memory Scanning

When not scanning you can select memories individual to be skipped by the scanner. Normally, when a memory is scanned (until the scanner is not activated), "SCAN" will appear on the display when that memory is recalled and the squelch is closed. To cause it to be skipped, just press the VFO•M key once. "SCAN" will disappear, and the memory will be skipped when you next start the scanner.

To re-enable scanning of a memory, just recall it, close the squelch, and press VFO•M once again (so "SCAN" is displayed).

PRIORITY CHANNEL MONITORING

Priority Monitoring allows you to tune and operate on a vfo while the receiver periodically checks a memory for a signal.

Before activating Priority Monitoring store the frequency (and mode) you want to check periodically in a memory, and adjust the squelch so that it is just closed. Then press the VFO side of the VFO/MR button to move to the vfo.

Press the PRI-M button. "PRI" appears just above the memory number, and you may now operate on the vfo as normal (even for transmitting). While you are receiving, every four seconds the display will jump to the memory to check briefly for activity.

If a signal appears on the memory frequency (strong enough to open the squelch), the receiver will stick on the memory for five seconds, during which you can press the PTT switch or the microphone momentarily (the transmitter will not be activated) to cancel priority monitoring and stay on the memory.

Note: While operating on the vfo, be careful not to press the PTT while the receiver is checking the memory unless you want to shift operation to the memory.

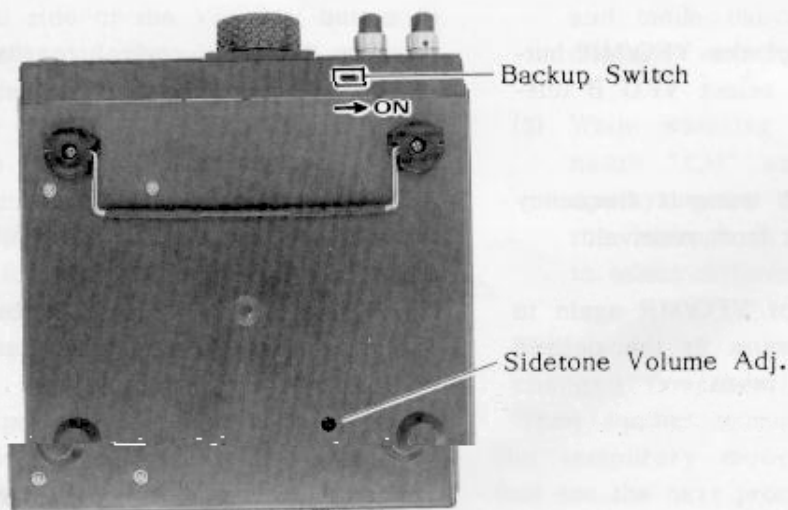

Controls Accessible Through Bottom Cover

5. MODIFICATIONS & OPTIONS

Top Cover Removal

The top cover of the FT-747GX must be removed as described here to install the modifications and internal options described afterwards.

- (1) Switch off the transceiver and disconnect all cables from the rear panel.
- (2) Referring to Figure 1 below, use a sharp instrument (such as a small screwdriver) to depress the catch pin in the strip on the side of the set (near the rear), while sliding the strip towards the rear with

your other hand. Do this on each side to remove both strips.

- (3) With the transceiver facing away from you, grasp the top panel with both hands near the front as shown in Figure 2. There are clips at positions (1) which can move only vertically, and a clip at (2) which can move only horizontally. Lift up on both sides to unlatch the clips at points (1) while holding the center clip (2) in the same position, and slide the top panel back about 2 centimeters ($\frac{1}{2}$ -inch) until the clips clear the top edge of the front panel.

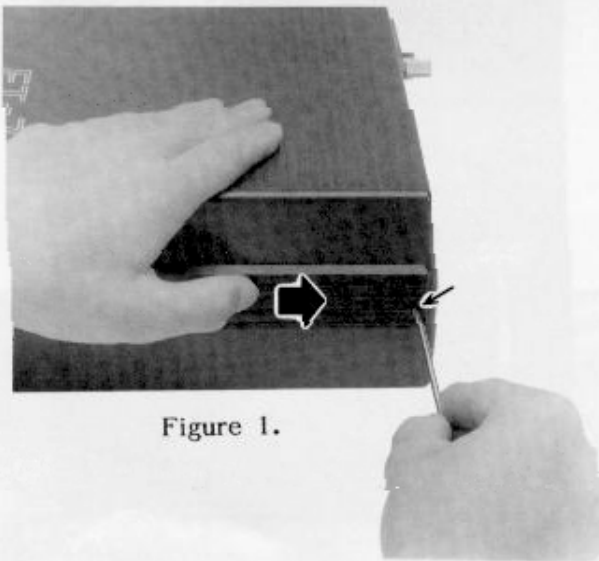

Figure 1.

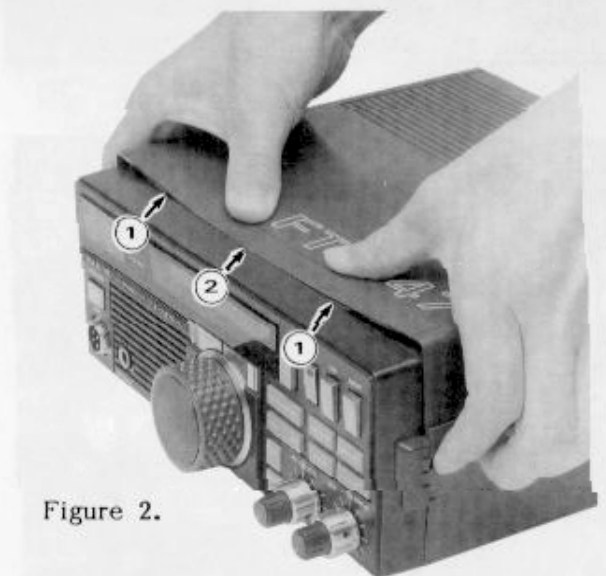
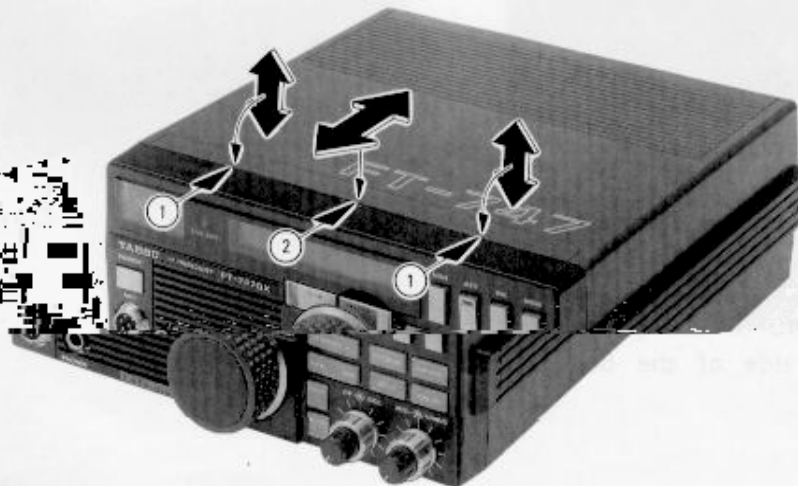
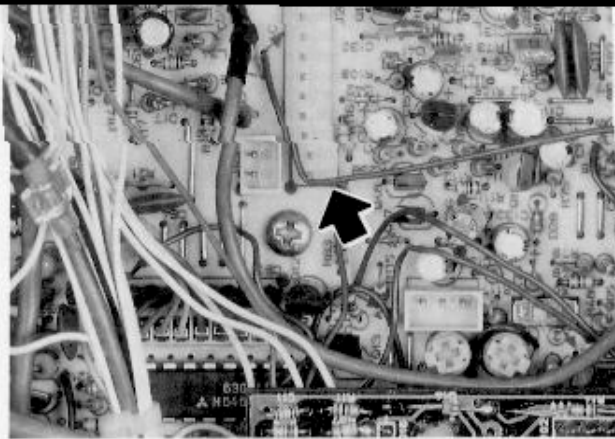

Figure 2.





Optional FM Unit Installation

The optional FM Unit can be installed in the 11-pin jack shown in the photo above, with the component side of the board facing to the left.

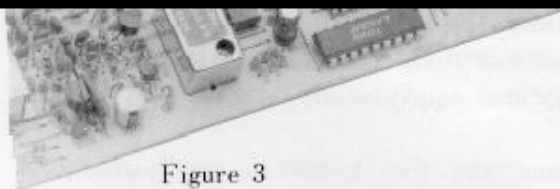
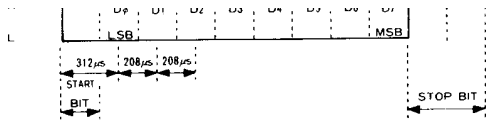

Figure 3





Data Format for 1 Character

All commands sent from the computer to the transceiver consist of blocks of five bytes each, with 50 to 200ms between each byte.

- (1) Build the four argument byte values from the desired frequency by breaking it into 2-digit blocks: technically referred to as "packed decimal" format. Note that a leading zero is always required in the hundreds-of-MHz place (and another in the ten's-of-MHz if below 10 MHz).

0 1 4 2 5 0 0 0

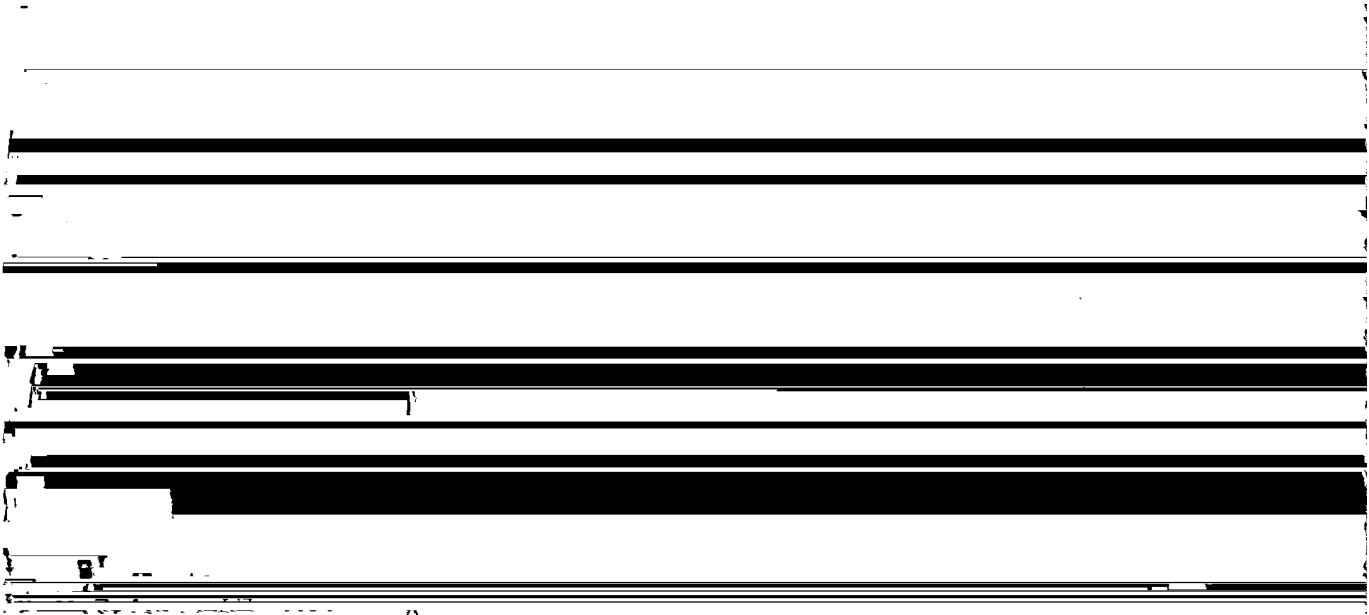

instruction opcode, while the first four bytes of each block are arguments: either parameters for that instruction, or dummy values (required to pad the block out to five bytes):

Step (2)	00h	05h	42h	01h	0Ah
	LSB		MSD	FREQ_SET	
	Frequency Parm's			Opcode	

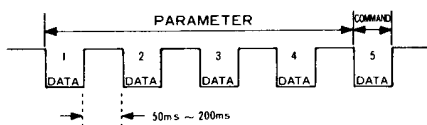

Data Format for 1 Block (5 Characters)

There are fourteen instruction opcodes for the FT-747GX, listed in the upper table on page 29. Notice that several instructions (UP500K, DN500K and UPDATE) require no parameters. However, every Command Block sent to the 767 must always consist of five bytes.

- (2) Now REVERSE the order of these bytes, and add the appropriate instruction byte on the end. The small "h"s following each byte value indicate hexadecimal (base 16) values (which in packed decimal format use the same digits as their decimal equivalents).
- (3) Send the five bytes to the transceiver, LSD (least significant digit) first (left-to-right as above).

Notice that there is space for a ten's-of-Hz digit in the frequency parameters, although

the transceiver to return 345 bytes of Status Update data, with each byte delayed by the interval selected by the PACING command (0 to 1,275ms in 5ms steps). This delay is initially zero until the PACING command is sent.

The PACING command allows Status Update data to be read and processed by even very slow computers. However, the pacing delay should always be selected to be as fast as your computer will accommodate, to minimize the inconvenience of the delay. Sending 345 bytes requires 790ms with "0"-length delay selected, but over 7 minutes if the maximum delay is selected!.

Status Update Data Organization

Status Update Data is mapped as shown in the lower table on page 29 and described below.

(1) Status Flags (1 byte)

The first byte of the Status Update data is the Status Flag Byte for the current display. Seven bits of this byte are used as flags to indicate the on/off status of the seven ele-

After the Status Flags byte is a 5-byte Frequency Block used for the operating frequency. The first byte of this block is reserved, and returns zero (00h). The last four of these bytes hold an 8-digit packed decimal representation of the operating frequency, which is not the same as that used by the FREQ SET command:

Frequency Block

Byte (relative to start of Block)

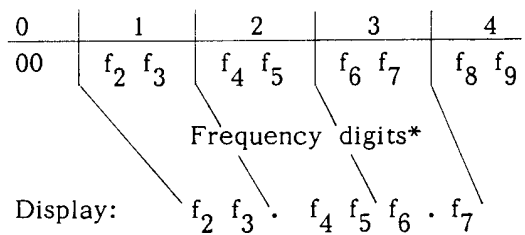

$f_8 f_9 = 00, 25, 50$ or 75 Hz (not displayed)

* Compare this with the parameters of the FREQ_SET command:

Parameter Byte			
1	2	3	4
$f_7 f_8$	$f_5 f_6$	$f_3 f_4$	$0 f_2$

the current data for VFO-A. The first byte is a Status Flags Byte, with the same format as already described for the current display. If currently operating on VFO-A, this byte is the same as the first Status Flags Byte (first byte of the Status Update data).

The next five bytes are the Frequency Block for VFO-A, with the same format as already

described in item (1) above.

(8) Memory Data (8 bytes x 38)

The next 304 bytes of the Status Update Data consists of thirty-eight 8-byte structures:

Memory Data Structure

- 1-byte Status Flags,
- 5-byte Frequency Block,
- 1-byte Mode Bit Map,

The last two bytes are reserved, and return indeterminate values (not necessarily zeros).

(5) VFO-B Data (8 bytes)

Following the VFO-A data are eight bytes holding the data for VFO-B, which has the same format as just described for VFO-A.

(6) Displayed Memory Number (1 byte)

The byte following the VFO-B data is the binary value of the currently displayed mem-

Each component in this structure has the same format as already described (items (1), (2) or (7) above). The first twenty structures represent receiver (or simplex) data for memories 00 through 19. The remaining 18 structures represent transmit data for any of memories 00 through 17 that were stored for split operation. Note, however, that if split operation was not stored, the data in the corresponding structure is indeterminate.

(9) The last sixteen bytes of the Status Update data are reserved, and undefined.

19-20	01h-10h	(5)	Displayed Memory No. (binary number between 00 and 13h)
21	17h	(6)	Displayed Mode (bit-mapped mode and IF filter selection)
22	18h	(7)	Memory 00 Rx Status Flags, Freq. Block, Mode and one reserved byte
23-32	19h-20h	(8)	Memory 01 Rx " " " " " " " " " "
33-40	21h-28h	(8)	Memory 01 Rx " " " " " " " " " "
.	.	.	.
.	.	.	.
177-184	B1h-B8h	(8)	Memory 19 Rx Status Flags, Freq. Block, Mode and one reserved byte
185-192	B9h-C0h	(8)	Memory 00 Tx Status Flags, Freq. Block, Mode and one reserved byte
193-200	C1h-C8h	(8)	Memory 01 Tx " " " " " " " " " "
.	.	.	.
.	.	.	.
321-328	141h-148h	(8)	Memory 17 Tx Status Flags, Freq. Block, Mode and one reserved byte
329-344	149h-158h	(9)	reserved (undefined)

100W PA UNIT F2947000 (No.5xxx)

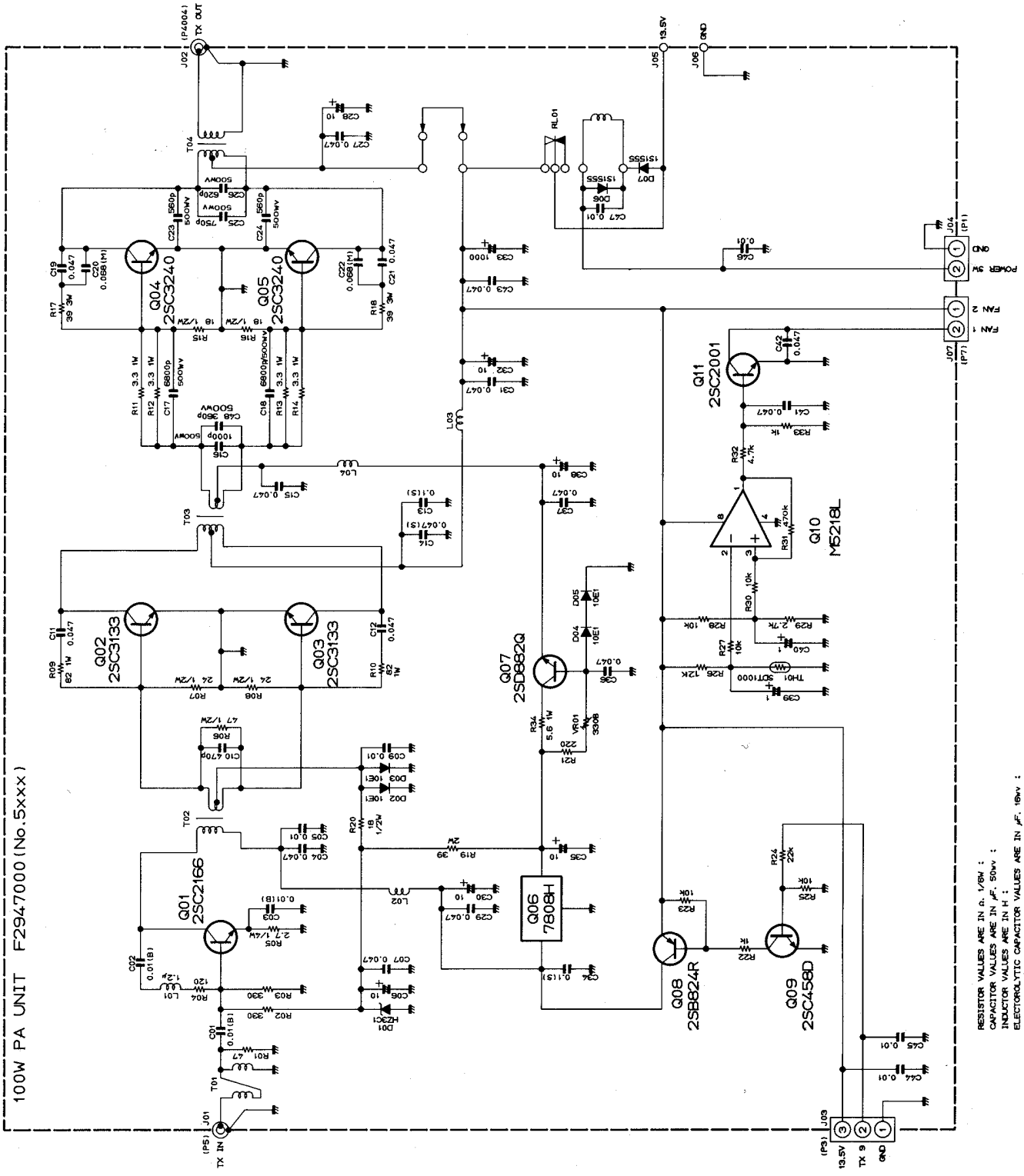

RESISTOR VALUES ARE IN Ω, 1/8W ;
 CAPACITOR VALUES ARE IN μF, 50V ;
 INDUCTOR VALUES ARE IN H ;
 ELECTROLYTIC CAPACITOR VALUES ARE IN μF, 16V ;
 UNLESS OTHERWISE NOTED,
 (M) CAPACITORS ARE POLYESTER FILM .50V,
 (S) CAPACITORS ARE SEMICONDUCTOR CERAMIC .25V.

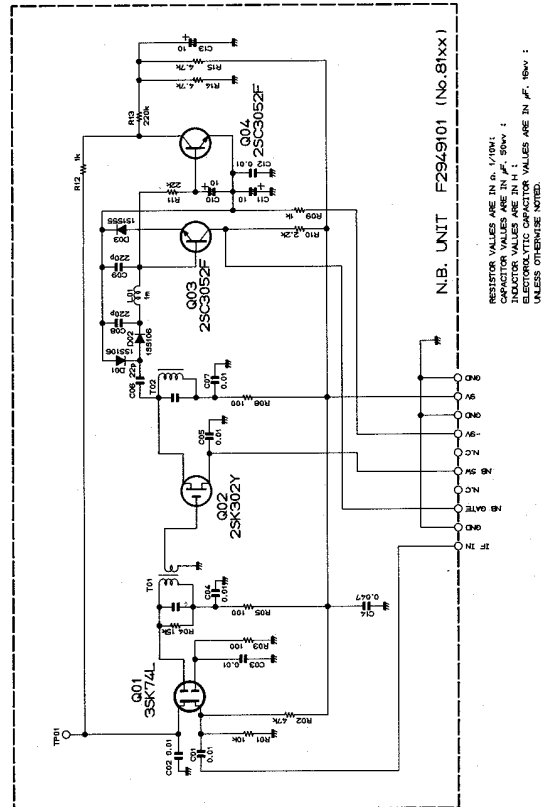
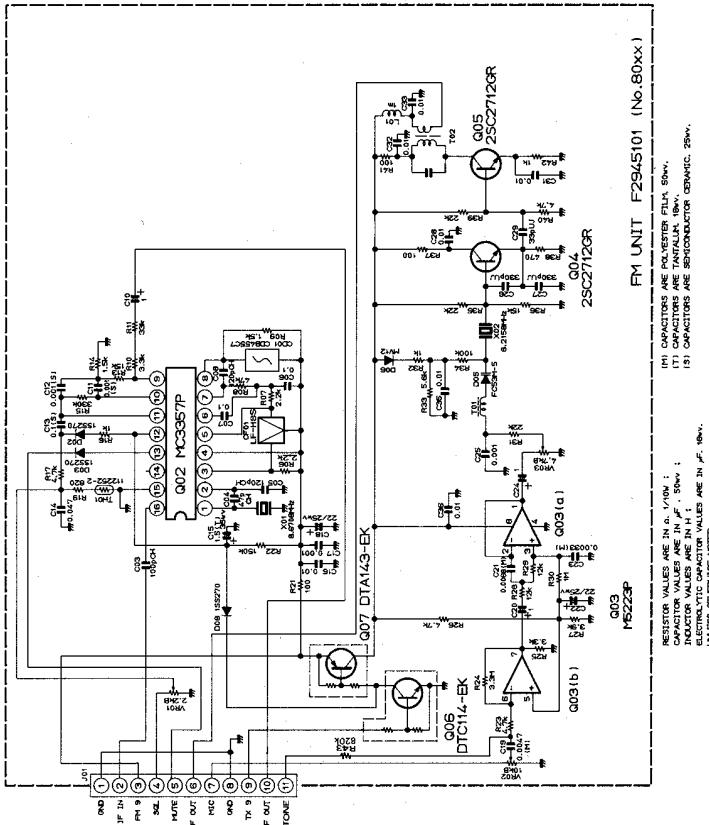
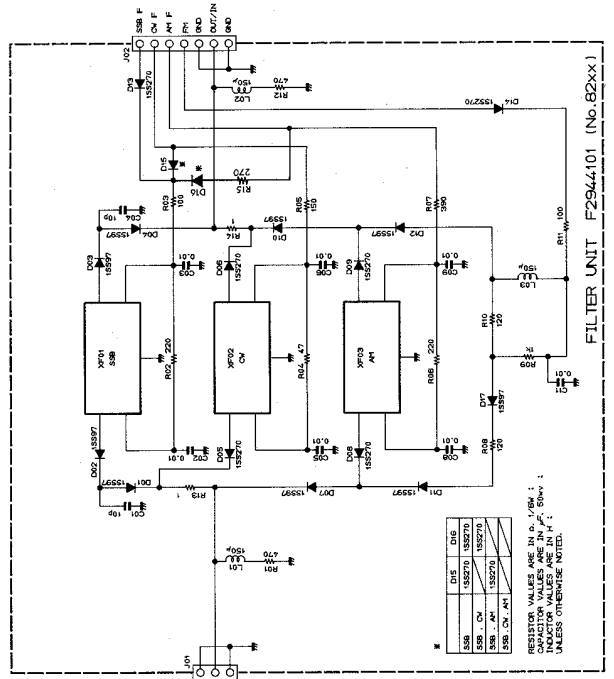
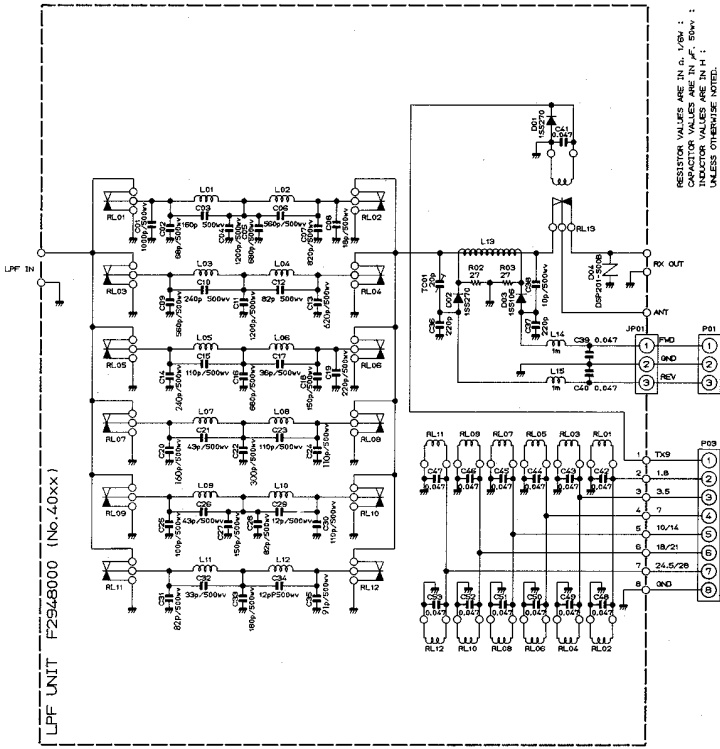

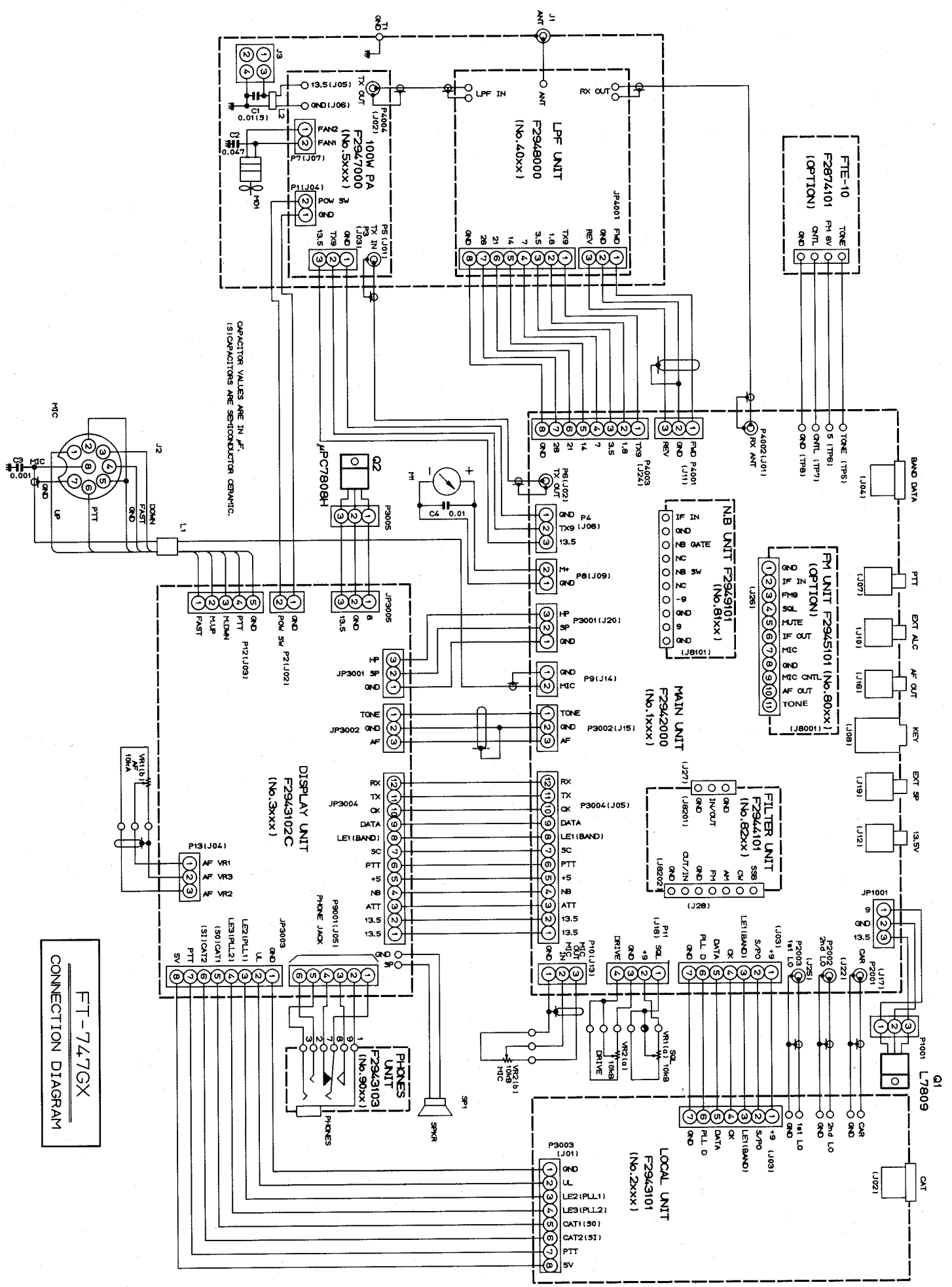

FT-747GX
CONNECTION DIAGRAM

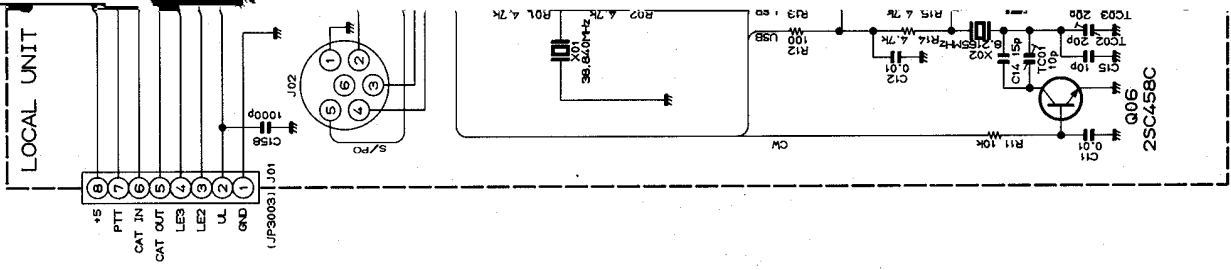

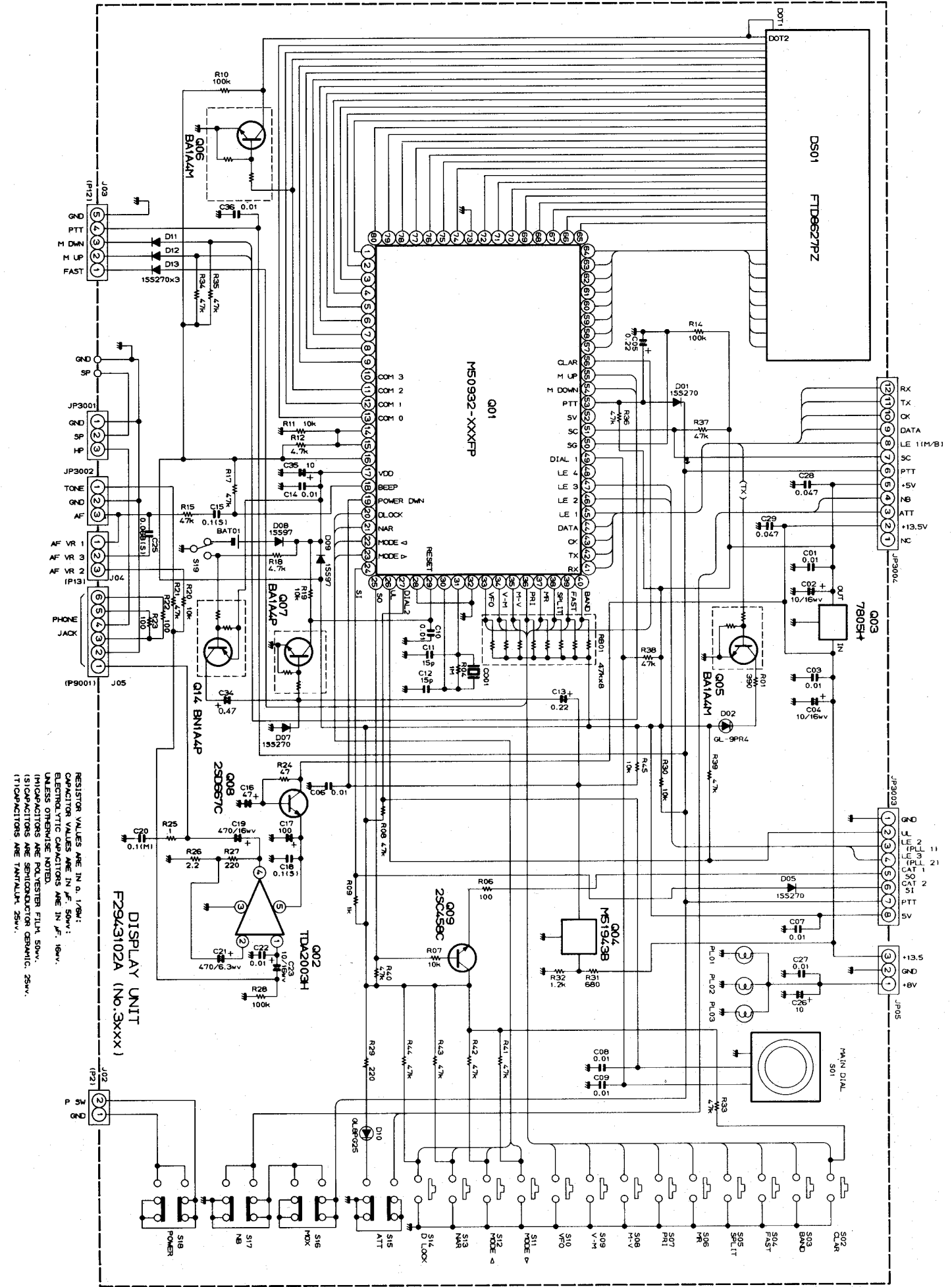

DISPLAY UNIT
F2943102A (NO.3xxx)

RESISTOR VALUES ARE IN Ω, 1KΩ,
CAPACITOR VALUES ARE IN pF, 500V;
ELECTROLYTIC CAPACITORS ARE IN μF, 16V;
UNLESS OTHERWISE NOTED.
(PIN/OPTIONS ARE SOLICITERS FILM 50V;
S1) CAPACITORS ARE SOLICITERS CERAMIC, 25V;
17) CAPACITORS ARE TANTALUM, 25V.

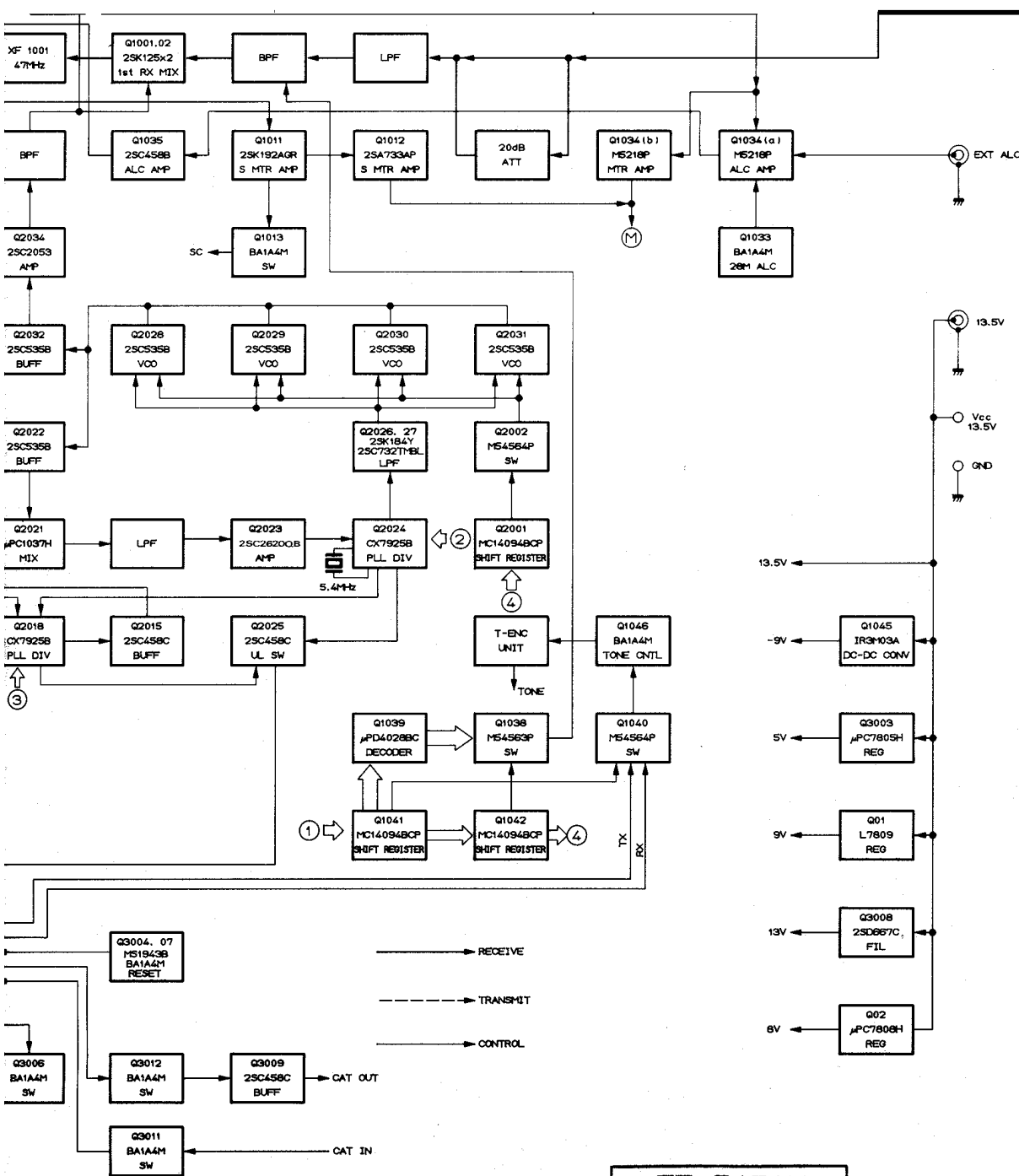

FT-747GX
BLOCK DIAGRAM

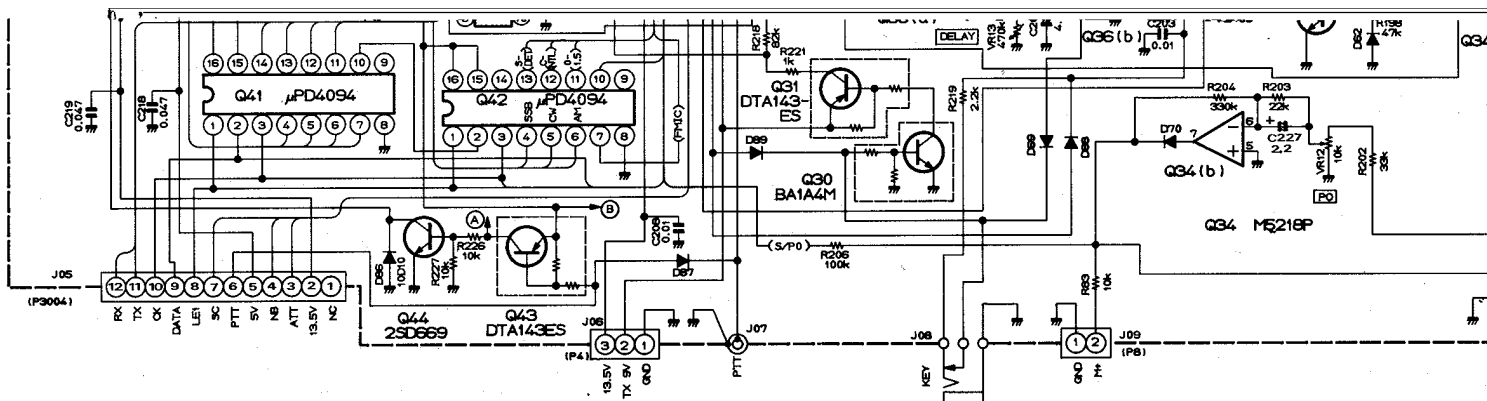

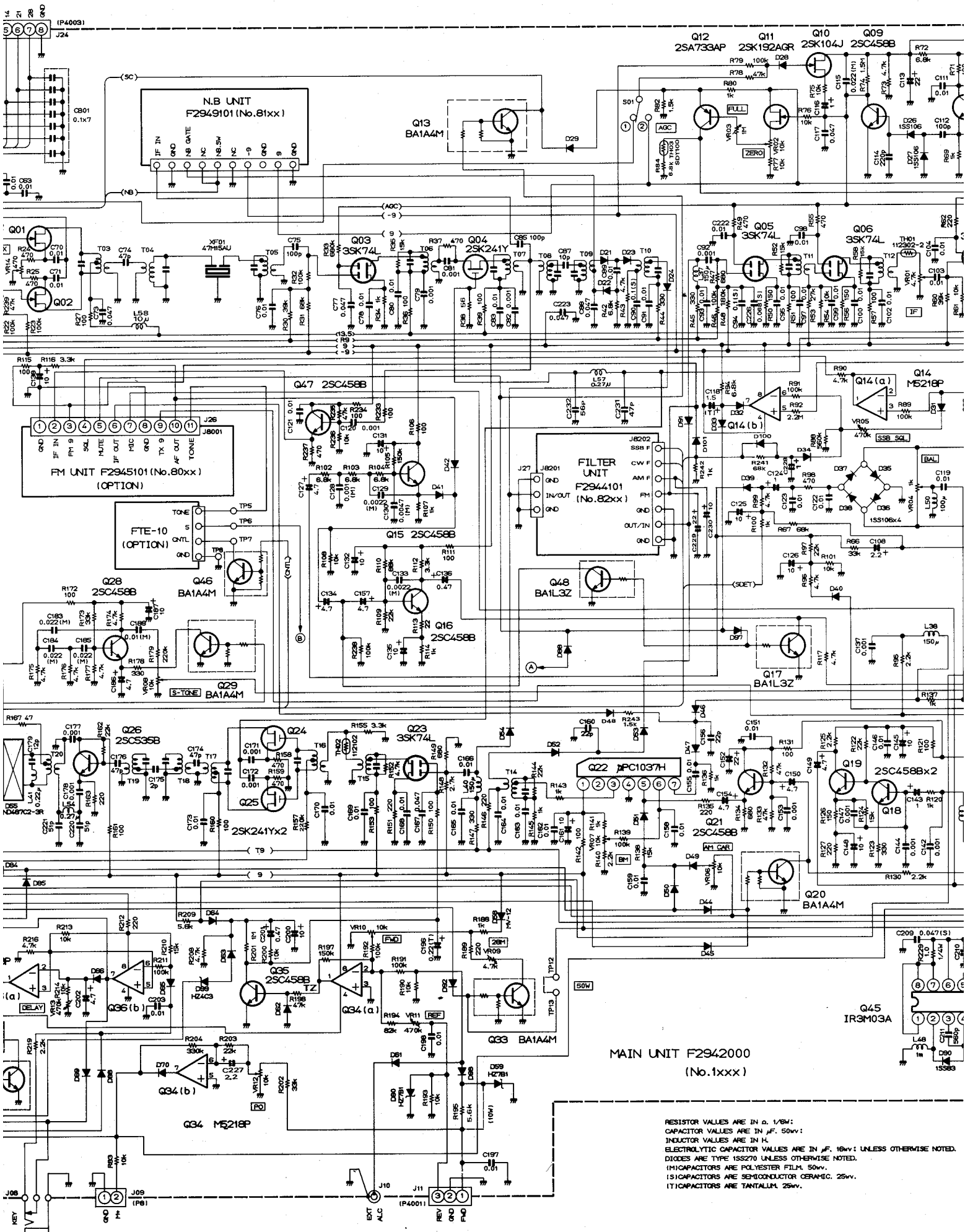

MAIN UNIT F2942000
(No. 1xxx)

RESISTOR VALUES ARE IN Ω, 1/8W;
 CAPACITOR VALUES ARE IN μF, 50v;
 INDUCTOR VALUES ARE IN H.
 ELECTROLYTIC CAPACITOR VALUES ARE IN μF, 16v; UNLESS OTHERWISE NOTED,
 DIODES ARE TYPE 1SS270 UNLESS OTHERWISE NOTED.
 (M) CAPACITORS ARE POLYESTER FILM, 50v.
 (S) CAPACITORS ARE SEMICONDUCTOR CERAMIC, 25v.
 (T) CAPACITORS ARE TANTALUM, 25v.

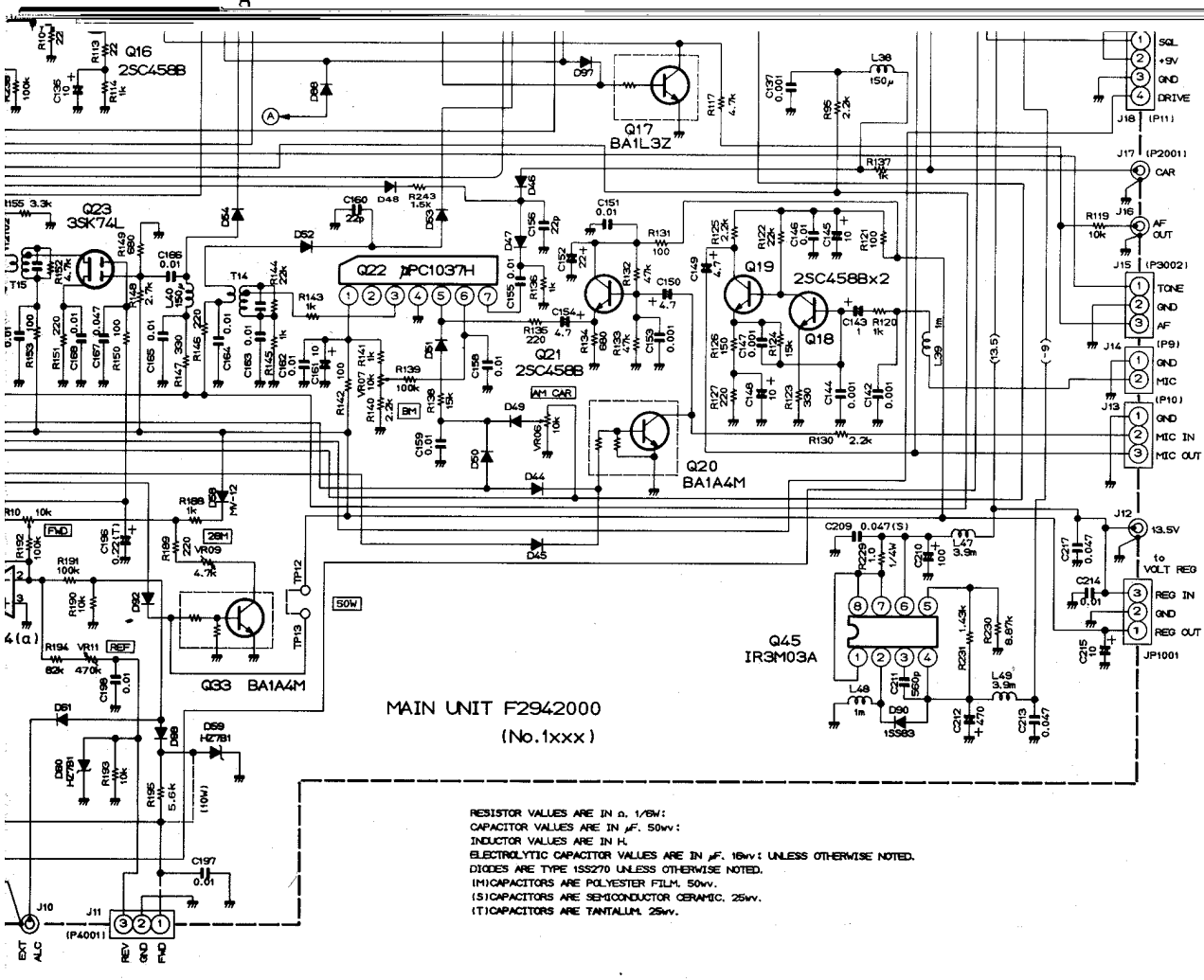

MAIN UNIT F2942000
(No.1xxx)

RESISTOR VALUES ARE IN Ω, 1/8W;
 CAPACITOR VALUES ARE IN μF, 50V;
 INDUCTOR VALUES ARE IN H;
 ELECTROLYTIC CAPACITOR VALUES ARE IN μF, 15V+1 UNLESS OTHERWISE NOTED.
 DIODES ARE TYPE 1SS270 UNLESS OTHERWISE NOTED.
 (M) CAPACITORS ARE POLYESTER FILM, 50V.
 (S) CAPACITORS ARE SEMICONDUCTOR CERAMIC, 25V.
 (T) CAPACITORS ARE TANTALUM, 25V.



E2530100(D804-ck)