



## SPECIFICATIONS

Frequency Range .....	1.8~29.9 MHz amateur bands, (160 thru 10m) 26.9~27.5MHz, 10~10.5MHz Receive only
Type of Emission .....	USB or LSB (selectable) CW, AM
Power Input .....	SSB 260 Watts PEP CW 180 Watts 50% duty cycle AM 80 Watts (slightly lower on 10 meters)
Carrier Suppression .....	50 db
Sideband Suppression .....	50 db at 1000 Hz
Spurious Radiation .....	Down 40 db or more
Transmitter Frequency Response .....	300 Hz - 2700 Hz $\pm$ 3 db
Distortion Products .....	Down 30 db or more
Antenna Output Impedance .....	50 - 75 ohm unbalanced
Frequency Stability .....	Less than 100 Hz drift in any 30 minute period
Sensitivity .....	0.3 uV S/N 10 db
Selectivity .....	(2.4 KHz at 6 db) SSB, AM, CW (4.0 KHz at 60 db) (600 Hz at 6 db) CW filter (option) (1.2 KHz at 60 db)
Audio Output .....	3 Watts
Power Consumption .....	AC Receive 45 Watts Transmit 350 Watts Max. DC 12V Standby 0.6 Amp. Transmit 21 Amps. Max.
Dimensions .....	13 1/2" wide, 6" high, 11 1/2" deep
Weight .....	Approx. 30 Pounds

## INSTALLATION

The transceiver is designed to provide a complete single unit installation for fixed, portable, or mobile operation. Two prewired plugs are furnished with the unit for AC or DC operation. This system provides the flexibility required for various installations and allows rapid change from fixed to mobile operation.

### Base Station Installation ;

The transceiver is designed for use in many areas of the world using supply voltages that may differ from the operators local supply voltage. Therefore, before connecting the AC cord to the power outlet, be sure that the voltage marked on the rear of the transceiver agrees with the local AC supply voltage.

### CAUTION

**Permanent damage will result if improper AC supply voltage is applied to the transceiver.**

The transceiver should be connected to a good ground. The ground lead should be connected to the terminal marked GND located on the rear panel of the transceiver.

### Mobile Installation ;

The transceiver will operate satisfactorily from any 12 volt negative-ground battery source by connecting the DC power cord to the rear panel receptacle. For under-dash mounting, a special mounting bracket is available from your dealer. A location should be selected clear of heater ducts. No special mounting precautions need be observed if adequate ventilation space is available. A minimum of two inches of air space above the cabinet top and on all sides is recommended to allow proper air flow around the cabinet. Never stack other units above or below the cabinet since the accumulated heat from both units could cause permanent damage.

The transceiver requires an average of 14 amps on transmit and 20 amps on voice peaks. The fuse in the DC power cable should be rated at 20 amps. When making connections to the car battery, be certain that the RED lead is connected to the positive (+) terminal

and the BLACK lead to the negative (-) terminal of the battery. Reversed connections could permanently

damage the transceiver. The BLACK lead should run directly to the negative terminal of the battery. Using the car frame as a negative connection or connecting the positive lead at a point such as the ignition switch places the devices creating noise in the same current path as the transceiver and fails to take advantage of the filtering action of the battery. The power cable should be kept away from ignition wires and be as short as possible to minimize voltage drop and to provide a low impedance path from the transceiver to the battery.

Prior to operating the transceiver in a mobile installation, the voltage regulator setting should be checked. In many vehicles, the voltage regulations is very poor and in some cases, the regulator may be adjusted for an excessively high charging voltage. As the battery and regulator age, the maximum voltage while charging can increase to a very high level which is injurious to the battery and could cause damage to the transceiver.

The transceiver is designed to operate from a source voltage range of 11 to 14 volts. It is necessary to carefully set the regulator so that the highest charging voltage does not exceed 14 volts. The transceiver should be switched "OFF" when vehicle is started to prevent voltage transients from damaging power supply transistors.

### Antenna ;

### CAUTION

**Never transmit without having proper antenna or dummy load connected to the transceiver**

The transceiver is designed for use with resonant antenna having an impedance 50 - 75 ohm resistive load.

The antenna is usually the most critical part of a station installation. Results both in receiving and transmitting will depend on how well the antenna is installed and adjusted. Any of the common antenna systems designed for use on the high frequency amateur bands may be used with the transceiver, provided the input impedance of the antenna system is within the capability of the transceiver pi-matching network (50-75 ohms).

ability of the transceiver pi-matching network (50-75 ohms).

If a tuned open wire transmission line, or a long wire antenna is used, a suitable antenna tuner must be used between the antenna and the transceiver to provide an impedance match between the unbalanced coaxial output of the transceiver and the balanced open-wire feeder or long wire.

For mobile operation, most of the commercially available antennas on the market will give good results with coaxial cable is securely grounded to the chassis of the vehicle at the antenna mount. Adjust the antenna length carefully for minimum SWR after installation.

### INTERCONNECTIONS

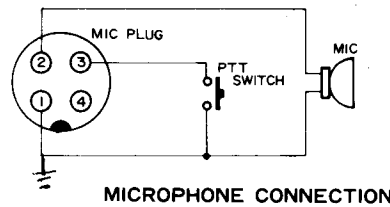
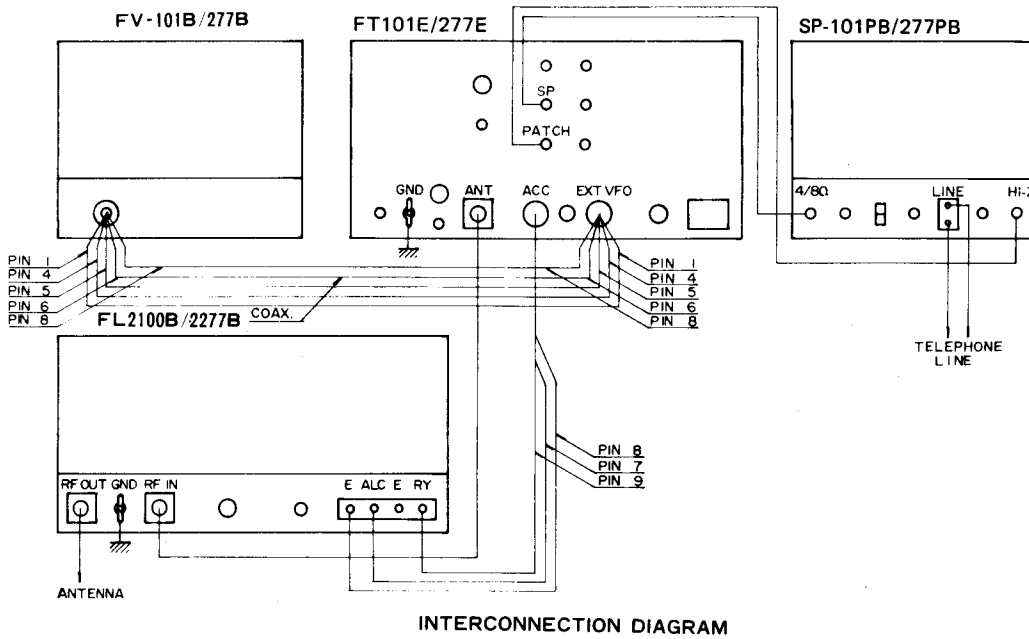

### WARNING

SERIOUS DAMAGE MAY RESULT TO THE INVERTER TRANSISTORS IF POWER PLUG OTHER THAN THOSE SUPPLIED WITH THE UNIT ARE UTILIZED. CINCH JONES OR OTHER SIMILAR U.S.A. VERSION CONNECTORS WILL FIT, HOWEVER THE PIN NUMBERING SYSTEM IS DIFFERENT.

**FTV-250/FTV-650B**  
**(2/6 METER TRANSVERTER)**

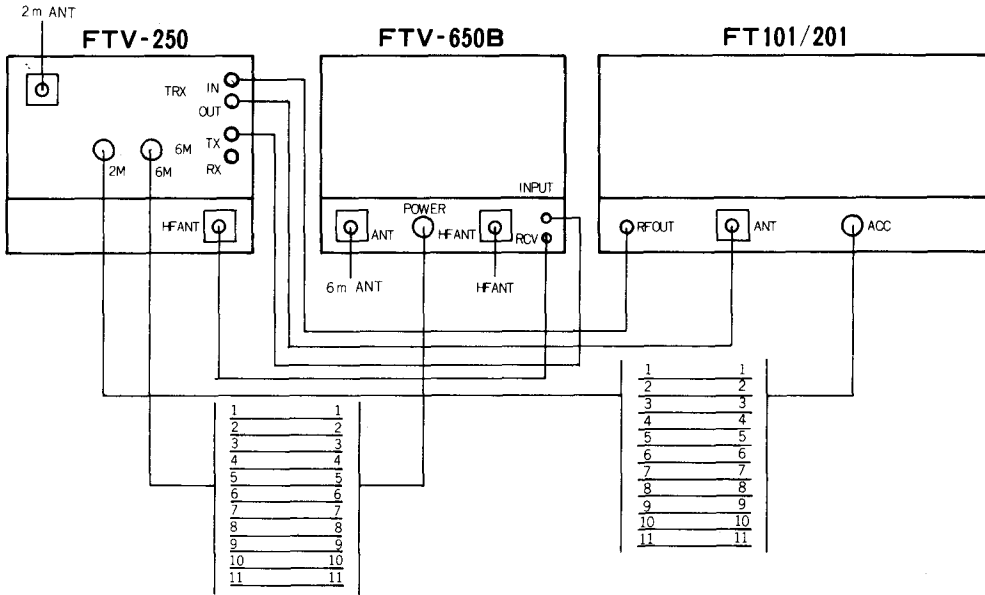



most readable point without affecting your transmitting frequency. Its use is particularly valuable in "net" operation where several participants may be transmitting slightly off frequency. The clarifier control functions with the clarifier switch (7) set to the push-down position, and a red warning lamp lights up. With the clarifier switch out position, the red lamp turns off and the receiver is locked to the transmitting frequency.

Normally, you will want to keep the clarifier in the OFF position until the initial contact is made. The clarifier control may then be used to zero-in and correct the any drift on the received signal.

(8) PRESELECT ;

This control pretunes the signal circuits for both transmit and receive. The preselect circuit provides continuous permeability tuning throughout the frequency range of the transceiver.

(9) MIC GAIN/CARRIER ;

The MIC GAIN/CARRIER controls are mounted on concentric shafts. The carrier control (lever control) varies the amount of the carrier in the CW, AM and TUNE modes of operation.

The MIC GAIN control (round knob) varies the output level from the microphone amplifier stage.

(C) MOX-PTT-VOX

This slide switch selects desired transmitter mode for both microphone and key operation.

MOX-(Manual transmit switch position)

Locks transmitter "ON" and must be returned to PTT position for receiver recovery.

PTT-(Push-to-talk)

Locks transmitter "ON" when microphone switch is depressed. Receiver recovers automatically when microphone switch is released.

VOX-(Voice operated transmit or break-in CW operation)

This switch position allows the operator to actuate the transmitter by simply speaking into the microphone. Receiver recovers automatically when the operator stops speaking.

For break-in CW, the VOX system will actuate the transmitter each time the key is depressed, and receiver recovers each time key is released.

(D) PROCESS

RF speech processor is placed into the circuit to increase the modulation power with this switch ON position.

(E) NB (NOISE BLANKER)

In upper position, the noise blanker is placed in



## OPERATION

The tuning procedure of the transceiver is not complicated, however, care should be exercised when tuning to insure peak performance of the equipment. The following paragraphs describe the procedure for receiver and transmitter tuning.

### INITIAL CHECK

Before connecting the transceiver to a power source, carefully examine the unit for any visible damage. Check that all modules and crystals are firmly in place and that controls and switches are operating normally. Ensure that voltage specification marked on rear panel matches the supply voltage.

### FREQUENCY SELECTION

The main tuning dial is color coded with the band selector switch for proper frequency read out. When band selected is marked in Red, the operator reads the Red numbers on the main tuning dial. When for example the band selected is marked in White on transceiver front panel, the operator reads the Black numbers on main tuning dial.

The main tuning dial is marked in 25 KHz increments between each 100 KHz segment. This provides a course frequency setting within the band. The dial skirt surrounding the tuning knob is marked in 1 KHz increments and provides for fine settings of the transceiver operating frequency.

Following the example shown, familiarize yourself with the relationship of main and skirt dial frequency read-out.

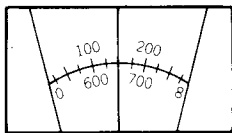

For bands 40-20-15-10A-10C read Black scale on main dial. Setting shown in the example would then be 148 KHz plus the starting band edge frequency in MHz. For example, on 40 meters the frequency would be 7.148 MHz. On 20 meters, 14.148 MHz, etc.

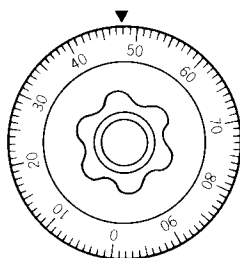

For bands 160-80-10B-10D read Red scale on main dial. Settings shown in the example would then read 648 KHz. For example, on 80 meters the frequency would be 3.648 MHz, on 10B, 28.648 MHz, etc.

### RECEIVER CALIBRATION ;

Preset the controls and switches as indicated :

VFO Selector ..... INT (internal)

MOX-PTT-VOX ..... PTT

POWER ..... ON (upper position)

RF GAIN ..... Maximum

AF GAIN ..... As required

BAND ..... Desired band

MODE ..... Desired mode

TUNING ..... 100 KHz point

PRESELECTOR ..... Desired band segment

CLARIFIER ..... OFF

RF ATT ..... OFF

CALIBRATOR ..... 100 KHz

To calibrate, set the TUNING control to the 100 KHz point on the dial nearest the desired frequency. Tune the preselector for maximum "S" meter deflection. Tune the transceiver to the 100 KHz calibrator signal for zero beat. Two signals may be heard near the 100 KHz point. One of these is a signal feeding through the IF stages. Always calibrate to the stronger of these two signals. To calibrate, hold tuning knob firmly at zero beat point and rotate skirt vernier dial to zero position. The skirt vernier dial surrounds the tuning knob and is held in position by a friction locking device. This dial is easily movable by hand but will retain its position after calibration. The transceiver must be calibrated when changing mode of operation of LSB, USB, AM or CW.

Switch the calibrator to the 25 KHz position and note that the calibrator signal can be heard at every 25 KHz point. The calibrator switch should be in the OFF position in normal use of the transceiver.

## TRANSMITTER TUNE-UP

The following tune-up procedure must be performed prior to selection of desired operating mode, LSB, USB, CW, or AM. See paragraphs relating to the specific mode after basic transmitter tune-up.

Connect dummy load or matched antenna to the coaxial fitting on rear apron, and preset controls as follows :

- POWER ..... OFF
- HEATER ..... ON
- MODE ..... TUNE
- CARRIER ..... 0 ( fully counter-clockwise)
- BAND ..... Desired band
- TUNING ..... Desired frequency
- PRESELECTOR ..... Desired band segment
- PLATE ..... Desired band segment
- LOADING ..... To position shown in table
- METER ..... IC
- VFO SELECT ..... INT
- MOX-PTT-VOX ..... PTT

### LOADING POSITIONS

BAND	LOADING
160 .....	5
80 .....	5
40 .....	5 1/2
20 .....	3 1/2
15 .....	3
11 10A .....	4 3/2
10B .....	4
10C .....	4
10D .....	4

NOTE : Loading positions are nominal. Slight variations

4. Adjust "PRESELECT" for maximum meter reading. (Caution: if meter exceeds .1 (100 mA), reduce "CARRIER")
5. Rotate "PLATE" control for minimum meter reading. (Plate Dip)
6. Return "MOX-PTT-VOX" switch to PTT position.

The transmitter is now pretuned to the desired frequency. Final peak tuning is accomplished by carefully following the final tuning procedure.

### FINAL TUNING

Final peak tuning utilizes the meter relative power output position (P.O.). At full transmit power the meter will read approximately one-half to two-thirds full scale into a matched antenna load. If during final tune-up it is noted that the meter indication exceeds full scale, discontinue tune-up. Off scale meter indications are the result of reflected RF due to high VSWR and corrective action should be taken before attempting final tune-up.

### CAUTION

**Exceeding the time limits noted during final tuning may result in destruction of final output tubes.**

1. Set meter switch to P.O. position, rotate "CARRIER" control arm fully clockwise to position 10.
2. Momentarily set "MOX-PTT-VOX" switch to "MOX" (10 second maximum), and rotate "PRESELECT" control for maximum meter reading. Return "MOX" to PTT position.
3. Momentarily set "MOX-PTT-VOX" switch to "MOX"

## SSB OPERATION

After completion of tuning, set MODE switch to LSB or USB. Set the METER switch to ALC position. Set the "MOX-PTT-VOX" switch to the PTT position and advance the MIC GAIN control until the meter kicks down to midscale of green colored portion when speaking normally into the microphone.

Set the "MOX-PTT-VOX" switch to VOX position. For VOX operation, adjust VOX GAIN potentiometer under the top cover until voice actuates the transceiver. Set the ANTITRIP potentiometer to the minimum point to prevent the speaker output from tripping the VOX. Do not use more VOX gain or ANTITRIP gain than necessary. Adjust the DELAY potentiometer under the top cover for suitable release time.

NOTE: When meter is set to IC, voice modulation peaks will indicate 150-200 mA. Actual peak current, however, is approximately 2 times the indicated value.

### CAUTION

**CARE must be taken to avoid an excessive drive to prevent spurious radiation. Maximum key down current should be kept within 330 mA for the bands under 15 meter and 280 mA for 10 meter band.**

## VOICE OPERATION WITH RF PROCESSOR

The FT-101E Speech Processor, when properly adjusted, is designed to improve the intelligibility threshold at the receiving end with RF clipping. This highly clipped IF signal is filtered to remove RF harmonics and out of band intermodulation products.

The distortion produced by RF envelope clipping and filtering is less objectionable than that caused by an equivalent amount of audio clipping.

It should be noted that the RF Speech Processor does not increase maximum power output but clips maximum peak to increase the output of low level signal as illustrated in Fig. 2, and the improvement of an RF Speech Processed Signal is most noticeable when the SSB signal is weak at a distant receiver.

With the PROCESS switch OFF, set the METER switch to ALC position. Normally speaking into the microphone, set the MIC GAIN control to the level where the meter indication stays in green portion of the meter scale. Set the PROCESS switch ON and adjust the LEVEL (processor output level) control to the position where the ALC indication stays in the green portion. Optimum setting of the MIC GAIN and LEVEL

controls may need observation of the transmitted signal by the scope.

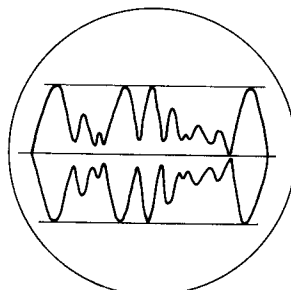

Fig. 1

Fig. 1 RF Processor OFF

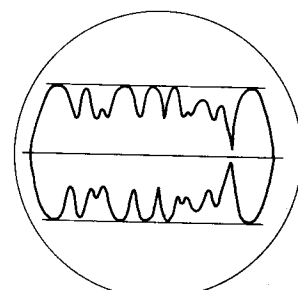

Fig. 2

Fig. 2 RF Processor ON

## CW OPERATION

Upon completion final tuning, insert key plug in jack marked "KEY" on rear apron of the transceiver. Power output from the transmitter is determined by the "CARRIER" control arm position. The operator may select any power output desired by simply rotating the "CARRIER" control within the limits of its range from zero to ten.

The transceiver may be operated manually or break-in by setting the "MOX-PTT-VOX" switch to either MOX (manual) or VOX (break-in) for the desired mode of operation.

NOTE: Insertion of the key plug automatically disconnects the bias supply to the PA tubes, therefore, with the key plug inserted Final Amplifier bias current will not be indicated when meter is in the IC position.

## AM OPERATION

AM operation of the transceiver is accomplished by setting the MODE switch to the AM position and inserting the proper amount of "CARRIER" with the "CARRIER" control.

After completion basic transmitter tune-up, place the MODE switch in the AM position and rotate "CARRIER" control arm until meter reads .15 (150 mA) in the IC position. While speaking into the microphone normally, increase MIC GAIN until the meter indicates very slight movement with voice peaks.

Care must be taken in adjusting MIC GAIN control to assure that the "CARRIER" control arm is not rotated causing an increase in "CARRIER" level. Do not exceed .15 (150 mA) meter indication during AM operation or destruction of the Final Amplifier tubes may result.

### CAUTION

**On the 160 meter band, maximum plate current should be kept within 140mA to avoid spurious radiation when it is operated on the frequencies between 1820 KHz and 1900 KHz.**

# CIRCUIT DESCRIPTION

The block diagram and the circuit description that follows will provide you with a better understanding of this transceiver.

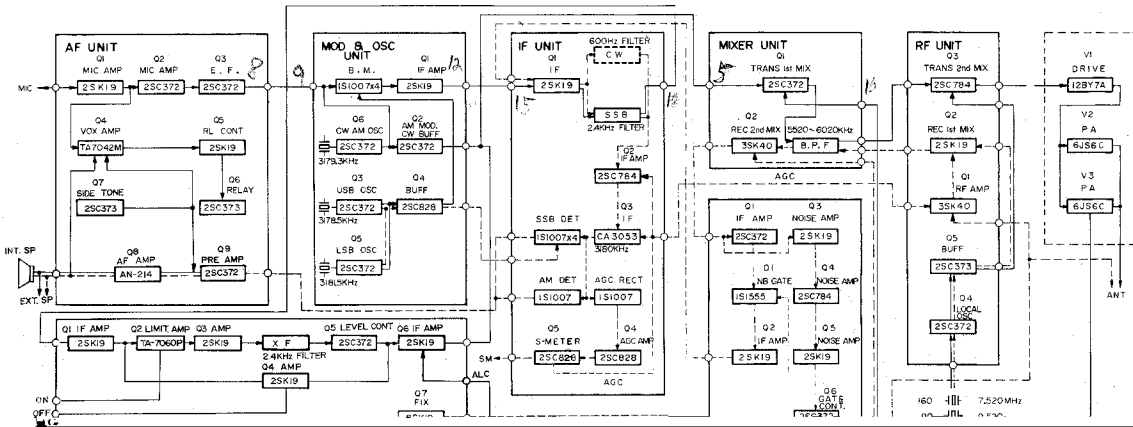













(C) FINAL AMPLIFIER

The signal from the transmitter second mixer is fed to the grid of transmitter driver V1, 12BY7A where it is amplified to a level sufficient to drive the final linear amplifier V2 and V3, 6JS6C. The signal appearing across T103 and T105 is coupled to the grids V2 and V3. Neutralization of the power amplifier is accomplished by feeding back a small amount of the output through TC27 to the bottom of T103/T105.

(11) METERING

The meter circuit is designed to indicate signal strength in the receive mode. On transmit, the meter may be switch selected to indicate cathode current, relative Power Output, and automatic level control. The meter functions are automatically switched by means of relay contacts for transmit and receive modes.

ALC meter reading is obtained from the source voltage of Q6, 2SK19GR which varies in ac-

## CRYSTAL CALCULATIONS FOR CRYSTAL CONTROLLED TRANSCEIVER OPERATION WITH THE EXTERNAL VFO OR THE TRANSCEIVER INTERNAL FIX OSCILLATOR, PB1534

The crystal holders accept standard HC-25/U type crystals. All crystal frequencies must fall between 8,700 KHz and 9,200 KHz. A trimmer capacitor has been connected in parallel with each crystal to permit proper frequency adjustment. Adjustment of this trimmer will change the crystal frequency approximately 1 KHz.

The correct crystal frequency for any desired operating frequency, may be determined by the following formula :

$$F_x = (F_1 + F_c) - F_o$$

$F_x = (F_1 + F_c) - F_o$ , where  $F_x$  is the crystal frequency,  $F_o$  is the desired operating frequency, and the constant  $(F_1 + F_c)$  is taken from the table.

**Frequency Table (F1 + Fc) Unit : KHz**

BAND	LSB	USB	AM/CW
160	10701.5	10698.5	10699.3
80	12701.5	12698.5	12699.3
40	16201.5	16198.5	16199.3
20	23201.5	23198.5	23199.3
15	30201.5	30198.5	30199.3
11	36201.5	36198.5	36199.3
10A	37201.5	37198.5	37199.3
10B	37701.5	37698.5	37699.3
10C	38201.5	38198.5	38199.3
10D	38701.5	38698.5	38699.3

For Example :

Find the proper crystal for operation at 3900 KHz LSB on the 80 meter band.

From the table find the constant  $(F_1 + F_c)$  for LSB operation on this band. The constant is 12701.5, therefore  $F_x = 12701.5 - 3900$   
 $= 8801.5$  KHz.

### CW FILTER INSTALLATION

1. Remove top cover of transceiver cabinet and locate printed circuit boards PB-1315A and PB-1183B.
2. Remove two screws holding PB-1315A to the U-shaped bracket. Remove two screws holding the U-shaped bracket to the shield plate, located between the two boards.

3. Remove PB-1315A from the chassis connector receptical. Gently, rock the circuit board out of the connector.
4. Remove the two screws holding the shield plate and lift out of the cabinet.
5. Grasping the U-shaped brackets still attached to PB-1183B gently, rock the circuit board out of the connector.
6. With PB-1183B removed from the chassis, remove C-10 and C-9 (.01 uF) capacitors from board. Install XF-30C CW filter in position indicated using the nuts and lockwashers provided. Solder the four filter terminals to the board.
7. Re-install PB-1183B into socket, screw shield plate to chassis, and re-install PB-1315A into socket. Replace all attaching screws.

This completes the CW filter installation. The filter provides a 600 Hz bandpass when the mode switch is placed in the CW position. Transceiver alignment is not required for this installation.

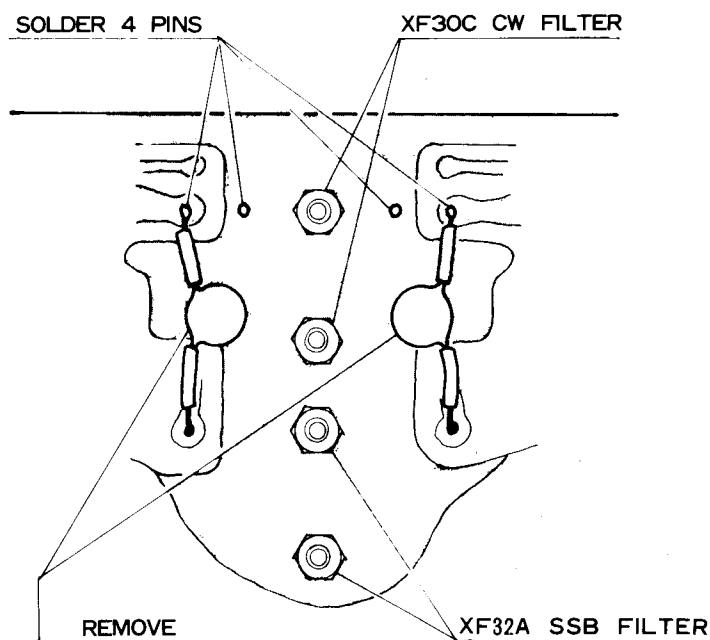





Adjust the DELAY control VR2 for suitable release time.

#### 4. CW SIDETONE LEVEL ADJUSTMENT

CW sidetone level may be adjusted by rotating TONE-level potentiometer (VR4) located on PB-1315A.

#### 5. CARRIER BALANCE

The transceiver should be allowed to reach operating temperature before making the carrier balance adjustment.

Tune-up the transceiver for SSB operation using an antenna or dummy load. Turn the MIC GAIN control fully counterclockwise to remove all audio from the modulator stage.

With the MODE switch set to either the LSB/USB positions, turn the "MOX-PTT-VOX" switch to the MOX position and adjust the carrier balance controls (VR1 and TC1) on PB-1184A for minimum PO meter reading.

A more exacting balance may be obtained by tuning a receiver, having an S-meter, to the transmitted frequency. Adjust the balance controls for minimum S-meter reading while switching the MODE switch back and forth between the two sideband positions to obtain good carrier suppression for both sidebands.

#### 6. ALC LEVEL ADJUSTMENT (EE/EX model)

The ALC meter will require adjustment if when the METER switch on the front panel is set to the ALC position, the mode switch to USB, the "MOX-PTT-VOX" switch to MOX and the microphone gain to zero the ALC meter does not read 5. To adjust the meter, set the controls as follows:

MODE .....USB  
MIC GAIN ..... Fully CCW  
MOX-PTT-VOX .....MOX

If the meter reads other than .5 on the bottom scale, adjust the ALC control VR2 on PB-1184A for a meter indication of .5. Return the "MOX-PTT-VOX" switch to the PTT position.

For the E model, please refer to the following RF processor adjustment.

#### 7. RF PROCESSOR

Set the controls and switches as follows:

MODE SSB (either LSB or USB)  
HEATER OFF  
METER ALC  
PROCESS OFF  
MIC GAIN Fully CCW position  
BAND Any Band

Set the operation switch to MOX position and adjust a potentiometer VR2 until the meter indicates exactly full scale without any modulation.

Connect the 1 kHz audio signal generator output of 10 mV to the MIC input. Adjust the MIC GAIN control until the audio input voltage becomes 30 mV at the gate of Q1, 2SK19GR. Peak T1 and T3 for maximum audio output at the output coil of T3. Set the VR1 for 30 mV output at T3.

Set the RF PROCESSOR switch to ON position and peak T2 for a maximum output.

#### 8. VOLTAGE REGULATOR ADJUSTMENT

Connect a VTVM DC probe between pin 13 of MJ 6 (PB-1314A) and ground. Adjust VOLT potentiometer VR3 for exactly 6 Volt reading on VTVM.

#### 9. CLARIFIER ADJUSTMENT

The frequencies coincide at CLARIFIER control OFF and 0 position in the receive mode. If not, adjust potentiometer VR4 located near the clarifier control potentiometer under the main chassis.

Transmit and receiver frequencies coincide at CLARIFIER control OFF position. If not, adjust ZERO potentiometer VR4 on PB-1314A

#### 10. BIAS ADJUSTMENT

The final amplifier bias must be checked to insure linearity and normal operating plate dissipation for the final tubes. Adjust the BIAS control VR2 on PB-1314A as follows: Set the transceiver to the receive mode and allow the transceiver to reach operating temperature.

Set MODE switch to USB, METER switch to IC and the "MOX-PTT-VOX" switch to MOX position for transmit condition. The meter will indicate PA plate current. Idle plate current is 60 mA if the bias is correct. If



### 13. ALIGNMENT OF TRANSMITTER MIXER/DRIVER AND RECEIVER FRONT END STAGES

The final amplifier bias adjustment must be set to 60 mA before extensive operation of the transmitter is

attempted. It is assumed that the signal generating stages of the transceiver are functioning properly. Use the internally generated signal of the transceiver to align the transmitter mixer and driver stages and the RF signal generator to align the receiver front end stage.

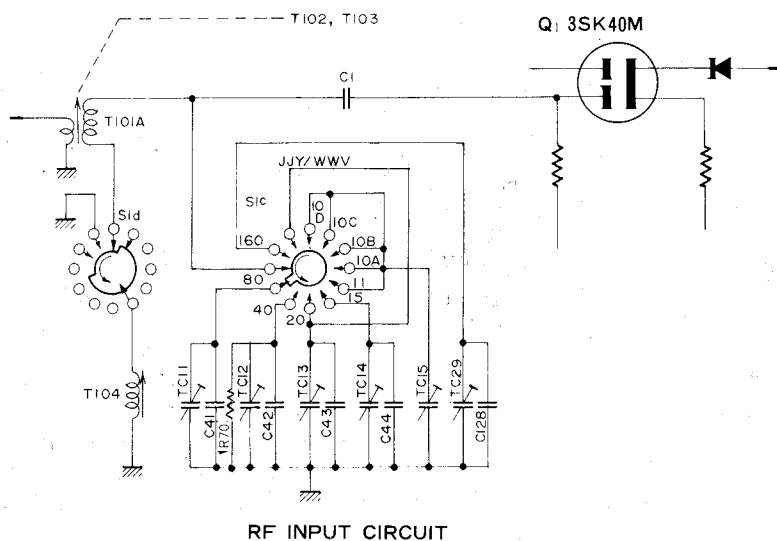

BAND	COIL	CAPACITOR	TRIMMER
160	T101A + T104	C128 820 PF	TC29
80		C41 240	TC11
40		C42 30P	TC12
20	T101A	C43 50 PF	TC13
15		C44 20 PF	TC14
10			TC15

- Connect the 50-ohm dummy load to the antenna Jack. Tune up the transceiver at 30,000 KHz (BAND 10D, VFO at 30,000 KHz) as follows ; Set the BAND switch to 10D, the VFO to 30,000 KHz, PRESELECTOR control to the upper end of 10 and 11 meter segment and the OPERATION switch at MOX. Advance the CARRIER control and tune the final amplifier. Maintain the resonant plate current (IC) at 100 mA with the CARRIER control. Set trimmer TC5 to the mid-capactance

Use just enough signal generator output (approximately 1 microvolt for an aligned unit) to keep from developing AGC voltage (no S-meter indication). Set trimmer TC15 to the mid capacitance position. Adjust a slug of T-101 for maximum audio output without developing AGC voltage.

- Set the BAND switch at 10A, the VFO at 28,000 KHz and the "MOX-PTT-VOX" switch at MOX. Advance the CARRIER control and tune the final

position and adjust the slugs of T102 and T103 for maximum output into the dummy load. Reduce the transmitter output to zero with the CARRIER control.

amplifier. Maintain the meter reading at 100 mA with the CARRIER control as described in step 1.

- Set the OPERATION switch to the receive mode, RF and AF GAIN control to maximum, CLARIFIER control to "OFF", and NOISE BLANKER to "OFF". Do not change the VFO setting and PRESELECTOR control setting set up in step 1. Tune the RF signal generator to 30,000 KHz and adjust it for approximately 1,000 Hz beat note.

Set the PRESELECTOR control to the lower end of 10 and 11 meter segment and adjust trimmer TC5 for maximum output at the dummy load. Reduce the transmitter output to zero with the CARRIER control.

- Set the OPERATION switch to the receive mode and without changing the VFO or PRESELECTOR control settings, tune the RF signal generator to 28,000 KHz and obtain 1,000 Hz beat note.

BAND	GRID CIRCUIT			PLATE CIRCUIT		
	COIL	CAPACITOR	TRIMMER	COIL	CAPACITOR	TRIMMER
160	T102+T106	C129 820P	TC28	T103+T105	C130 820P	TC10
80		C4 200P	TC1		C9 200P	TC6
40		C5 30P	TC2		C106 30PF	TC7
20	T102	C6 50PF	TC3	T103	C10 50PF	TC8
15			TC4		C107 10PF	TC9
10			TC5			

### 12BY7A TUNING CHART

Control the signal generator output and adjust trimmer TC15 for maximum audio output as described in step 2.

(5) Repeat step 1, 2, 3 and 4 to peak out the coil adjustments for the 10 meter band.

(6) Set the BAND switch to 15, the VFO to 21,000 KHz and the PRESELECTOR to the lower edge of the 15 meter segment. Tune up the transceiver to 21,000 KHz as described above. Adjust trimmers TC4 and TC9 for maximum transmitter output into the dummy load.

(7) Set the OPERATION switch to the receive mode, and without changing the VFO or PRESELECTOR settings. Tune the RF signal generator to 21,000 KHz and obtain the 1,000 Hz beat note. Adjust trimmer TC14 for maximum audio output as described in step 2.

(8) Repeat the procedures given in step 6 and 7 on the 20 meter band. The trimmer TC3 and TC8 are used for maximum transmitter output and TC13 for maximum audio output in receive.

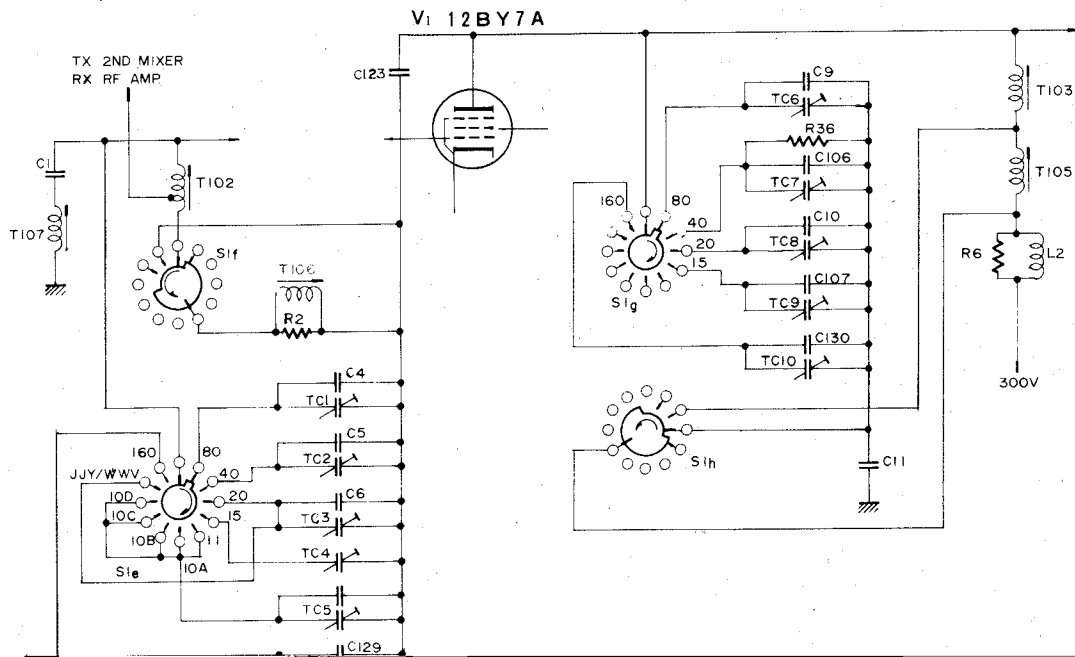





## 15. TRAP COIL ALIGNMENT

- (1) T107 is used to eliminate the direct-feed-through interference at the IF frequency, and tuned to 5.720 KHz. Set the transceiver at 7,300 KHz LSB in receive mode and peak the PRESELECTOR for maximum noise output. Set the RF signal generator to 5.720 KHz and increase the signal generator output until an audio beat note is heard. Adjust T107 for minimum audio output.
- (2) L29 on the printed circuit board located near the antenna change-over relay RL2 is also used to eliminate the direct-feed-through interference. Set the transceiver at 7,080 KHz in the receive mode. Tune the RF signal generator to 5,940 KHz. Adjust L29 for minimum S-meter reading.
- (3) L22 eliminates the interference by 9th harmonic of the carrier oscillator. Tune the transceiver to 28,600 KHz USB in the receive mode, and increase RF and AF gain control until an audio beat note is heard. Adjust L22 for minimum audio output.

### CAUTION

**Continuous full output for more than 10 seconds may result in destruction of final tube.**

- (4) T113 in the high frequency IF unit is used to eliminate spurious radiation on the 20 meter band. For alignment, tune transceiver to maximum output at 14,350 KHz in the tune position. Measure the spurious radiation, by using the S-meter of another receiver tuned to 14,520 KHz where a spurious radiation can be heard. Adjust T113 for minimum S-meter reading without decreasing the power output of the transceiver.
- (5) T115 is located on the printed circuit board near the VFO unit and is used to suppress carrier oscillator feed-through. Tune the transceiver to any frequency and load it to full output. Reduce the microphone gain to zero and place the mode switch in the USB position. Adjust T115 for minimum S-meter reading on the receiver.
- (6) L28 is used to eliminate spurious radiation on the 15 meter band. Tune the transceiver to maximum output at 21,200 KHz in the tune position. Locate the spurious radiation at 21,220 KHz by another receiver. Adjust L28 for minimum S-meter reading on the receiver.
- (7) TC30 connected in series with L32 on the printed circuit board located on the main chassis near the relay RL1 is used to eliminate spurious radiation on 10 meter band. For alignment, tune transceiver to maximum output at 28,500 KHz in the tune position. Measure the spurious radiation by using the S-meter of another receiver tuned to 28,160 KHz where the spurious signal can be heard. Adjust TC30 for minimum S-meter reading without decreasing the power output of the transceiver.

### VOLTAGE CHART

		D.C. VOLTAGE														R.F. VOLTAGE															
MJ	PIN	1		2		3		4		5		6		7		1		2		3		4		5		6		7			
		R	T	R	T	R	T	R	T	R	T	R	T	R	T	R	T	R	T	R	T	R	T	R	T	R	T	R	T		
	1	E	E	E	E	E	E	E	E	E	E	E	E	0	0	E	E	E	E	E	E	E	E	E	E	E	E	E	E	E	E
	2	E	E	E	E	0	0	0	0	0	0	-70	-55	E	E	E	E	E	E	—	—	—	—	—	—	—	—	—	—	E	E
	3	6.0	6.0	0	0	13.0	12.5	0	0	0.7	0.7	-18	0	E	E	* 3	* 3	3180KHz 77dB	0	—	—	—	—	—	—	—	—	—	E	E	
	4	0.5	0.5	E	E	0	0	0	0	8.5	8.5	-20	-3.5	0	0	* 2	* 2	E	E	—	—	—	—	—	—	—	—	—	—	—	—
	5	5.5	5.5	13.0	12.5	0	0	0	0	6.0	6.0	-150	-140	0	13.0	—	—	—	0.03	0.08	0	—	—	—	—	—	—	—	—	—	
	6	6.0	6.0	E	E	0	0	E	E	0	0	170	170	0	0	—	—	E	E	—	—	E	E	0.8	0.8	—	—	—	—	—	
	7	E	E	13.0	12.5	E	E	0	0	E	E	0	0	13.5	12.5	E	E	—	—	E	E	—	—	E	E	—	—	—	—	—	
	8	0	0	E	E	0	11.5	0	0	0	0	0.6	2.7	1.0	1.0	14MHz 48dB	—	E	E	—	—	—	—	—	—	—	—	—	—	—	
	9	8.0	13.0	12.0	0	9.0	9.0	9.0	9.0	0	0	12.5	0	E	E	—	—	—	—	—	—	—	—	—	—	—	—	—	E	E	
	10	0	11.5	E	E	6.5	0.35	-18	0	13.0	12.5	0	11.5	E	E	—	—	E	E	3180KHz 80dB	0.01	—	—	—	—	—	—	E	E		
	11	13.0	12.5	0	0	13.0	12.5	E	E	0	0	3.5	3.5	—	—	14MHz 60dB	2	0.12	0.12	—	—	E	E	—	—	—	—	—	—	—	
	12	12.5	0	E	E	0.7	0.7	9.0	9.0	6.6	0.3	13.5	13.0	—	—	—	—	E	E	—	—	—	—	—	—	0.5	—	—	—		
	13	12.0	0	0	11.5	8.0	13.0	0	0	12.5	0	6.0	6.0	—	—	—	0.15	—	—	—	—	—	—	—	—	—	—	—	—		
	14	13.0	12.5	E	E	E	E	6.0	6.0	12.5	0.3	13.0	12.5	—	—	—	—	—	E	E	E	—	—	—	—	—	—	—	—		
	15	0	0	13.0	12.5	0	0	13.0	12.5	—	—	0	0	—	—	—	—	5720KHz 55dB	0.5	3180KHz 94dB	0.06	—	—	—	—	—	—	—	—		
	16	0	11.5	13.0	0	0	0	13.0	12.5	—	—	0	0	—	—	—	—	5720KHz 73dB	0.15	—	—	—	—	—	—	—	—	—	—		
	17	13.0	12.5	E	E	0	0	0	0	—	—	0	0	—	—	5720KHz 55dB	0.5	E	E	3180KHz 83dB	0.15	—	—	—	—	—	—	—	—		
	18	E	E	E	E	0	0	E	E	—	—	E	E	—	—	E	E	E	E	—	—	E	E	—	—	E	E	—	—		
	19	—	—	—	—	13.0	12.5	0	0	—	—	—	—	—	—	—	—	—	—	—	—	E	E	—	—	—	—	—	—		
	20	—	—	—	—	0	0	E	E	—	—	—	—	—	—	—	—	—	—	—	—	—	—	—	—	—	—	—	—		
	21	—	—	—	—	0	0	E	E	—	—	—	—	—	—	—	—	—	—	—	—	—	—	—	—	—	—	—	—		
	22	—	—	—	—	E	E	0	0	—	—	—	—	—	—	—	—	—	—	E	E	—	—	—	—	—	—	—	—		
VALUES ARE IN VOLTS D.C. R: RECEIVE, T: TRANSMIT														MODE: USB, BAND: 20M, R: RECEIVE, T: TRANSMIT VALUES WITHOUT ANY UNIT ARE IN VOLTS R.M.S. VALUES WITH DB ARE SIGNAL GENERATOR OUTPUT LEVELS TO PRODUCE S-9. VALUES GIVEN UNDER THE COLUMN T ARE SIGNAL LEVELS TO PRODUCE 100W OUTPUT POWER MODULATED BY 1KHz MIC INPUT.																	

### RESISTANCE CHART

MJ PINNO.	PB-1181 RF 1	PB-1182 MIX 2	PB-1183 I.F. 3	PB-1315 A.F. 4	PB-1184 CARRIER REDUCTION 5	PB-1314 REC./CALIB. 6	PB-1292 D.I.S. 7
1	E	E	E	E	E	E	∞
2	E	E	150	30K	0	10K	E
3	300	0	10	0	∞	4K	E
4	3K	E	∞	*	10K	10K	0
5	300	∞	0	∞	200	30K	0
6	200	E	1K	E	5	50K	0
7	E	10	E	0	E	3K	10
8	0	E	0	1K	5K	6K	100K
9	2.5K	120	10K	10K	1K	120	E
10	*	E	3K	50K	10	0	E
11	100	∞	10	E	1M	3K	—
12	120	E	1K	50K	3K	10	—
13	120	0	3K	∞	1.2K	200	—
14	10	E	E	200	700	10	—
15	0	100	∞	10	—	50K	—
16	0	100	∞	10	—	0	—
17	100	E	∞	*	—	∞	—
18	E	E	∞	∞	—	E	—
19	—	—	10	*	—	—	—
20	—	—	120	E	—	—	—
21	—	—	200	E	—	—	—
22	—	—	E	*	—	—	—

VALUES ARE IN OHMS.

Order Instruction: Parts number is independent for each unit, except T-transformers and T-inductors, therefore it is requested to specify parts number together with unit classification as following example.

No. 1 RF Unit R1 100K ohm  $\frac{1}{4}W$  \* VALUE IS NOMINAL

RF UNIT				17	50WV	0.047 $\mu$ F
PRINTED CIRCUIT BOARD PB-1181(A~Z)						
<b>Q FET &amp; TRANSISTOR</b>						
4	TR.	2SC372Y		14~16	CERAMIC FEED THRU	
5	TR.	2SC373			500WV	0.001 $\mu$ F
3	TR.	2SC784R		18	ELECTROLYTIC 16WV	1 $\mu$ F
2	FET	2SK19GR		<b>TC TRIMMER CAPACITOR</b>		
1	FET	3SK40M		1~3	CERAMIC	ECV1ZW50P32 50PF
<b>D DIODE</b>						
1, 2	Si.	1S1555		<b>L INDUCTOR</b>		
<b>R RESISTOR</b>						
22	CARBON FILM	$\frac{1}{4}W$	56 $\Omega$	1	BPF-A	
23		$\frac{1}{4}W$	100 $\Omega$	2	BPF-B	
16, 24		$\frac{1}{4}W$	220 $\Omega$	3	BPF-C	
6		$\frac{1}{4}W$	330 $\Omega$	34	RF CHOKE 1.95 $\mu$ H	
10, 19		$\frac{1}{4}W$	470 $\Omega$	4, 8	RF CHOKE 250 $\mu$ H	
11		$\frac{1}{4}W$	560 $\Omega$	<b>T TRANSFORMER &amp; INDUCTOR</b>		
9, 13		$\frac{1}{4}W$	1K $\Omega$	112A	IF TRANSFORMER	
7		$\frac{1}{4}W$	1.8K $\Omega$	113	TRAP COIL	
8		$\frac{1}{4}W$	2.2K $\Omega$	<b>X CRYSTAL</b>		
17, 20		$\frac{1}{4}W$	3.3K $\Omega$	1	HC-18/U	6360KHz
21		$\frac{1}{4}W$	8.2K $\Omega$	<b>IF UNIT</b>		
14, 18		$\frac{1}{4}W$	15K $\Omega$	PRINTED CIRCUIT BOARD PB-1183(A~Z)		
2		$\frac{1}{4}W$	22K $\Omega$	<b>Q FET, IC &amp; TRANSISTOR</b>		
4		$\frac{1}{4}W$	82K $\Omega$	2	TR.	2SC784R
1, 3, 5, 12		$\frac{1}{4}W$	100K $\Omega$	4, 5	TR.	2SC828Q
<b>VR VARIABLE RESISTOR</b>						
1	TR-11R		5K $\Omega$ B	3	1C	TA7045M
<b>C CAPACITOR</b>						
17	DIPPED MICA	50WV	6PF	1	FET	2SK19GR
5		50WV	50PF	<b>D DIODE</b>		
1, 11		50WV	100PF	1~5, 7~11	Ge.	1S1007
3	CERAMIC DISC	50WV	0.001 $\mu$ F	6	Si.	1S1555
2, 4, 7~10, 12~16,		50WV	0.01 $\mu$ F	12	Zener	WZ-110
6, 18		50WV	0.047 $\mu$ F	<b>R RESISTOR</b>		
19	ELECTROLYTIC	16WV	47 $\mu$ F	2, 13, 16	CARBON FILM	$\frac{1}{4}W$ 100 $\Omega$
<b>L INDUCTOR</b>						
1, 2	RF CHOKE		1mH	23		$\frac{1}{4}W$ 220 $\Omega$
3	RF CHOKE		250 $\mu$ H	28		$\frac{1}{4}W$ 330 $\Omega$
<b>MIXER UNIT</b>						
PRINTED CIRCUIT BOARD PB-1082(A~Z)						
PB-1180(A~Z)						
<b>Q FET &amp; TRANSISTOR</b>						
1	TR.	2SC372Y		20		$\frac{1}{4}W$ 470 $\Omega$
2	FET	3SK40M		12, 15, 19		$\frac{1}{4}W$ 1K $\Omega$
<b>D DIODE</b>						
1	Si.	1S1555		3, 14		$\frac{1}{4}W$ 2.2K $\Omega$
<b>R RESISTOR</b>						
12	CARBON FILM	$\frac{1}{4}W$	10 $\Omega$	22		$\frac{1}{4}W$ 2.7K $\Omega$
5, 7		$\frac{1}{4}W$	100 $\Omega$	8, 9		$\frac{1}{4}W$ 3.3K $\Omega$
13		$\frac{1}{4}W$	470 $\Omega$	11		$\frac{1}{4}W$ 3.9K $\Omega$
3, 16, 17		$\frac{1}{4}W$	1K $\Omega$	4, 5		$\frac{1}{4}W$ 5.6K $\Omega$
2		$\frac{1}{4}W$	4.7K $\Omega$	17, 24, 25, 27		$\frac{1}{4}W$ 10K $\Omega$
14, 15		$\frac{1}{4}W$	5.6K $\Omega$	10		$\frac{1}{4}W$ 27K $\Omega$
10		$\frac{1}{4}W$	10K $\Omega$	1, 18, 21, 26		$\frac{1}{4}W$ 100K $\Omega$
4, 6		$\frac{1}{4}W$	15K $\Omega$	6, 7	CARBON COMPOSITION	$\frac{1}{2}W$ 100 $\Omega$
11		$\frac{1}{4}W$	22K $\Omega$	<b>VR VARIABLE RESISTOR</b>		
1		$\frac{1}{4}W$	27K $\Omega$	1	TR12R	500 $\Omega$ B
8		$\frac{1}{4}W$	100K $\Omega$	2	TR11R	500 $\Omega$ B
9		$\frac{1}{4}W$	220K $\Omega$	<b>C CAPACITOR</b>		
<b>C CAPACITOR</b>						
6, 19	DIPPED MIBA	50WV	20PF	1, 24, 25	DIPPED MICA	50WV 100PF
1		50WV	40PF	15, 22		50WV 150PF
8		50WV	150PF	11, 17		50WV 470PF
2		50WV	470PF	26~28	CERAMIC DISC	50WV 0.001 $\mu$ F
7	CERAMIC DISC	50WV	0.001 $\mu$ F	2~6, 9, 10, 12, 13, 18, 20,		50WV 0.01 $\mu$ F
<b>CAPACITOR</b>						
				21, 23, 31~34		
				7, 8, 14, 16, 19, 35	50WV	0.047 $\mu$ F
				29	PLASTIC FILM	50WV 0.47 $\mu$ F
				30	ELECTROLYTIC	16WV 10 $\mu$ F
<b>L INDUCTOR</b>						
				1~4	RF CHOKE	250 $\mu$ H
<b>T TRANSFORMER &amp; INDUCTOR</b>						
				108	IF TRANSFORMER	
				109	IF TRANSFORMER(DETECTOR)	
<b>XF CRYSTAL FILTER</b>						

1	XF-32A SSB			R	RESISTOR		
2	XF-30C CW(OPTION)			18	CARBON FILM $\frac{1}{4}$ W		100 $\Omega$
				1, 3	$\frac{1}{4}$ W		150 $\Omega$
				19	$\frac{1}{4}$ W		180 $\Omega$
	AF UNIT			2, 21, 30	$\frac{1}{4}$ W		470 $\Omega$
	PRINTED CIRCUIT BOARD PB1315(A~Z)			9~11, 14, 24, 28	$\frac{1}{4}$ W		1K $\Omega$
Q	FET, IC & TRANSISTOR			20	$\frac{1}{4}$ W		1.5K $\Omega$
2, 3	TR. 2SC372Y			6, 8	$\frac{1}{4}$ W		2.2K $\Omega$
6, 7	TR. 2SC373			12, 15, 16, 22, 25, 26, 29	$\frac{1}{4}$ W		4.7K $\Omega$
9	TR. 2SC1000GR			32	$\frac{1}{4}$ W		10K $\Omega$
1	FET. 2SK19GR			33	$\frac{1}{4}$ W		15K $\Omega$
5	FET. 2SK19Y			13, 17, 23, 27	$\frac{1}{4}$ W		22K $\Omega$
8	IC AN214			7	$\frac{1}{4}$ W		33K $\Omega$
4	IC TA-7042M			4	$\frac{1}{4}$ W		100K $\Omega$
D	DIODE						
1, 2, 3, 4	1S1555			VR	VARIABLE RESISTOR		
5	WZ-090			1	TR11R		500 $\Omega$ B
				2	TR11R		5K $\Omega$ B
R	RESISTOR			C	CAPACITOR		
13, 14	CARBON FILM $\frac{1}{4}$ W		100 $\Omega$	20, 28, 30	DIPPED MICA 50WV		30PF
53	$\frac{1}{4}$ W		120 $\Omega$	19, 27, 32	50WV		40PF
41	$\frac{1}{4}$ W		220 $\Omega$	38	50WV		50PF

<b>VR</b>	<b>VARIABLE RESISTOR</b>			<b>T</b>	<b>TRANSFORMER</b>		
4	TR11R		500ΩB	116~119	IF TRANSFORMER R12-4129		
3	TR11R		1KΩB				
2	VI60KRZ-1		10KΩB				
					<b>FIX/RF PROCESS UNIT</b>		
<b>C</b>	<b>CAPACITOR</b>				PRINTED CIRCUIT BOARD PB-1534		
7~9	DIPPED MICA	50WV	30PF	<b>Q</b>	<b>IC, FET &amp; TRANSISTOR</b>		
5, 10		50WV	40PF	2	IC	TA7060P	
1		50WV	100PF	1, 3, 4, 6, 7	FET	2SK19GR	
2		50WV	250PF	5	TR	2SC372Y	
3		50WV	2000PF				
4, 6	CERAMIC DISC	50WV	0.01μF	<b>D</b>	<b>DIODE</b>		
17	PLASTIC FILM	50WV	0.001μF	1	Si	1S1555	
15		50WV	0.1μF	2	Varactor	1S2236	
20		250WV	0.047μF	<b>XF</b>	<b>CRYSTAL FILTER</b>		
13, 14	DLECTROLYTIC	16WV	1000μF	1	XF-30A		
16		16WV	100μF	<b>XS</b>	<b>CRYSTAL SOCKET</b>		
11, 12		25WV	1000μF	1	S-14 2P		
21		150WV	22μF				
18, 19, 22		250WV	22μF	<b>R</b>	<b>RESISTOR</b>		
<b>TC</b>	<b>TRIMMER CAPACITOR</b>			23	CARBON FILM	¼W	56Ω
1	CERAMIC	ECVIZW50P40	50PF	2, 3, 5, 10, 15, 20, 24	¼W		100Ω
				11	¼W		470Ω
<b>L</b>	<b>INDUCTOR</b>			7, 9	¼W		1KΩ
1, 2	RF CHOKE		4mH	6, 16, 19	¼W		2.2KΩ
				1, 4	¼W		3.3KΩ
<b>X</b>	<b>CRYSTAL</b>			8, 12, 14, 17	¼W		10KΩ
1	HC-13/U		100 kHz	13, 18, 21, 22	¼W		100KΩ
	<b>NB UNIT</b>			<b>VR</b>	<b>POTENTIOMETER</b>		
	PRINTED CIRCUIT BOARD PB-1292(A~Z)			1	V10K8-1-2		500B
<b>Q</b>	<b>FET &amp; TRANSISTOR</b>			2	V10K8-1-2		5KB
1, 6	TR.	2SC372Y					
4	TR.	2SC784R					
2, 3, 5	FET	2SK19GR					
<b>D</b>	<b>DIODE</b>			<b>C</b>	<b>CAPACITOR</b>		
1~3	Si	1S1555		26	DIPPED MICA	50WV	20PF
4	Zener	WZ090		29		50WV	51PF
				4	CERAMIC DICS	50WV	20PF(CH)
				19		50WV	27PF(CH)
				9, 15		50WV	100PF(CH)
				1~3, 5~8, 10~14		50WV	0.01μF
<b>R</b>	<b>RESISTOR</b>			16~18, 20, 22~25, 27, 28			
4, 13	CARBON FILM	¼W	100Ω	21		50WV	0.047μF
16		¼W	330Ω				
3		¼W	560Ω	<b>TC</b>	<b>TRIMMER CAPACITOR</b>		
6, 8, 12, 19		¼W	1KΩ	1, 2	ECV-1ZW20P32 20PF		
18		¼W	1.5KΩ				
15		¼W	2.2KΩ	<b>T</b>	<b>TRANSFORMER</b>		
9, 11, 21, 22		¼W	3.3KΩ	1~3	R 12-4424		

1

¼W

4.7KΩ



<b>TC</b>	<b>TRIMMER</b>	<b>CAPACITOR</b>		<b>MJ</b>	<b>MULTI JACK</b>		
5	CERAMIC	ECV1ZW10P32	10PF	1, 2, 6		3305-018-011	18P
1~4, 11~25		ECV1ZW50P32	50PF	3, 4		3305-022-011	22P
7, 8, 9		MICA B-1PY	40PF	5		3305-014-011	14P
6, 31		B-2PY	100PF	7		3305-010-011	10P
10, 26, 28, 29		B-7P	420PF				
27	AIR	TSN-150C	10PF	<b>PL</b>	<b>LAMP</b>		
30	PLASTIC FILM	CTY12B	10PF	1, 2, 4		16V 0.15A	
				3		14V 40mA	
				5, 6		LED TLR-104	
<b>L</b>	<b>INDUCTOR</b>			<b>PLH</b>	<b>LAMP HOLDER</b>		
12, 13, 16~18, 20, 21, 26, 31, 35	RF CHOKE		250 $\mu$ H	1, 2		#001011	
3, 11, 36	RF CHOKE(TV-245)		250 $\mu$ H	3		B-1	
9	RF CHOKE(PLATE)		300 $\mu$ H				
7	RF CHOKE(PLATE)		500 $\mu$ H				
2	RF CHOKE		1mH	<b>J</b>	<b>RECEPTACLE &amp; JACK</b>		
24	P.S. $\frac{1}{2}$ W56 $\Omega$ 0.3 $\phi$ 10TS			1, 4, 5, 7, 8, 11, 16~18		CN-7017	
1, 4, 37	P.S. $\frac{1}{2}$ W56 $\Omega$ 0.6 $\phi$ 4TS			2		S-G7616(KEY)	
5, 6	P.S. 1W56 $\Omega$ 1.0 $\phi$ 4TS			10		S-G7814(PHONE)	
8	TANK COIL			3		FM-144(MIC)	
22	TRAP COIL			6		JSO-239(ANT)	
28	TRAP COIL			9		450AB12M(POWER)	
29	TRAP COIL			12		P2240(SP)	
32	TRAP COIL			13		S-B0611(EXT. VFO)	
33	TUNING COIL			14		SA602B(ACC)	
25	L. P. FILTER COIL			15		S-16303(FAN)	
14, 15	RF CHOKE		35 $\mu$ H				
<b>T</b>	<b>TRANSFORMER &amp; INDUCTOR</b>			<b>M</b>	<b>METER</b>		
101A	ANT COIL A			1		MK-45	
102	GRID COIL A						
103	DRIVER COIL A						
104	ANT COIL B						
105	DRIVER COIL B						
106	GRID COIL B						
107	5MHz TRAP COIL						
111	OSC COIL						



T 10

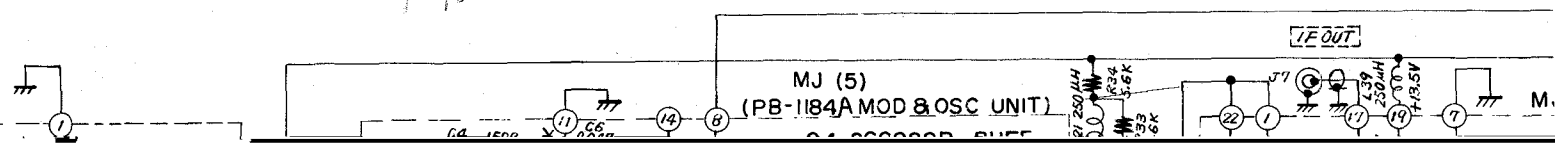





PRESELECT

V2 V3 PA  
6JS6C X2

