

 **YAESU**

FT-100D

OPERATING MANUAL

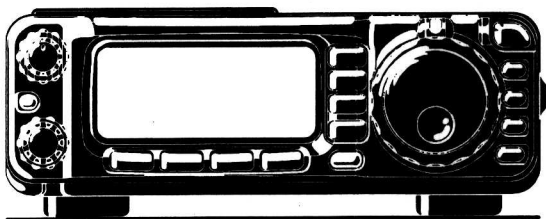

MICRO MOBILE

YAESU MUSEN CO., LTD.

4-8-8 Nakameguro, Meguro-Ku, Tokyo 153-8644, Japan

YAESU U.S.A.

17210 Edwards Rd., Cerritos, CA 90703, U.S.A.

YAESU EUROPE B.V.

P.O. Box 75525 1118 ZN, Schiphol, The Netherlands

YAESU UK LTD.

Unit 12, Sun Valley Business Park, Winnall Close
Winchester, Hampshire, SO23 0LB, U.K.

YAESU GERMANY GmbH

Am Kronberger Hang 2, D-65824 Schwalbach, Germany

YAESU HK LTD.

11th Floor Tsim Sha Tsui Centre, 66 Mody Rd.,
Tsim Sha Tsui East, Kowloon, Hong Kong

Contents

General Description	1	SSB Transmission	48
Specifications	2	Basic Setup/Operation	48
Plug/Connector Pinout Diagrams	4	VOX Operation	48
Accessories & Options	5	AF Speech Processor Operation	49
Installation	6	CW Transmission	50
Installing the Microphone and Front Panel	6	Operation using Straight Key/External Keying Device	50
Power Connections	8	Operation using Built-in Electronic Keyer	51
Grounding	10	Operation using Message Memory keyer	52
Antenna Considerations	12	FM Operation	53
RF Field Exposure	16	Simplex (Non-Repeater) Operation	53
Electromagnetic Compatibility	17	Repeater Operation	54
Heat and Ventilation	17	CTCSS Encode and Tone Squelch Operation	55
Accessory Interfacing	18	DCS Operation	56
Connection of Headphones	23	DTMF Operation	57
Adjusting the Front Feet	23	ARTS™ (Auto Range Transpond System) Operation ..	57
Front Panel Controls and Switches	24	CW Identifier Setup	57
Microphone Switches	29	Split Frequency Operation	58
Rear Panel Connectors	30	Time-Out Timer	58
Basic Operation	32	Digital Mode Operation	59
Before You Start	32	RTTY (Radio TeleType) Operation	59
Operation Quick Start	32	Packet (300 BPSHF or 1200/9600 BPSFM) Operation ..	60
Turning the Transceiver On and Off	32	Operation on Alaska Emergency	
Amateur Band Selection	32	Frequency: 5167.5 kHz	61
Mode Selection	33	Active-Tuning Antenna System	
Setting the Audio Volume Level	33	(ATAS-100) Operation	62
Setting the Operating Frequency	33	FC-20 Automatic Antenna Tuner Operation ...	66
Receiver Operation	34	Memory System Operation	68
Operating Function Selector ([FUNC] key)	34	QMB Channel Programming/Recall	69
Memory Operation "Banked" Memory Channels	34	Memory Operation "Banked" Memory Channels	69

General Description

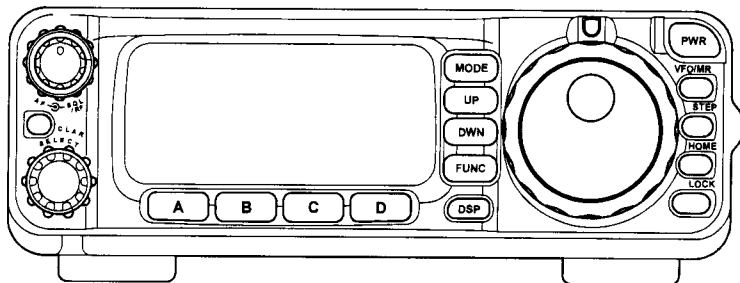

The exciting new Yaesu FT-100 is a revolutionary multimode transceiver providing coverage of all nine MF/HF Amateur bands, plus VHF/UHF coverage of the 50, 144, and 430 MHz bands.

The FT-100's extraordinarily compact design, combined with the remote-head mounting capability (optional YSK-100 Separation Kit required) allows mounting in the most compact vehicular applications. Engineered for high performance, the FT-100 provides 100 Watts power output on the 160 through 6 meter bands, 50 Watts output on 2 meters, and 20 Watts output on 70 centimeters.

Among the leading-edge features of the FT-100 are Digital Signal Processing (Bandpass Filtering, Noise Reduction Notch, and Microphone Equalizer), Dual VFOs, four available IF bandwidths of 6 kHz, 2.4 kHz, 500 Hz, and 300 Hz (optional filters required for AM/CW), and extensive FM operating features such as CTCSS Encode (Decoder optional), DCS Encode/Decode, Automatic Repeater Shift, and ARTS (Auto-Range Transponder System). A convenient rear-panel jack allows effortless interface to Terminal Node Controllers for 300/1200/9600 bps Packet or AFSK operation on RTTY, AMTOR, and other Digital modes. CW operators will enjoy the built-in Message Memory Electronic Keyer, DSP-based narrow-bandwidth filter, and full QSK operation.

The unique Yaesu Icon display provides indication of the current operating features, along with warnings to the operator such as "High SWR," antenna problems, overheating of the power transistors, etc.

Thank you for your investment in the FT-100. We recommend that you read this manual in its entirety as soon as possible, so as to gain a fuller understanding of the many capabilities of your new transceiver.

Specifications

General

Frequency Range:

Receive 100 kHz – 970 MHz (European version)
100 kHz – 824 MHz, 849 – 864 MHz,
and 894 – 961 MHz (U.S.A. version)

Transmit 160 – 6 Meters

2 Meters

70 Centimeters (Amateur bands only)

Emission Modes:

(U.S.A. version only)
A1 (CW), A3 (AM), A3J (LSB/USB),
F1 (9600 bps Packet), F2 (1200 bps Packet), F3 (FM)

Synthesizer Steps (Min.):

1.25 Hz (CW/SSB), 100 Hz (AM),
100 Hz (FM), 1 kHz (FM)

Antenna Impedance:

50Ω, Unbalanced

Operating Temp. Range:

-10 °C to +60 °C (14 °F to 122 °F)

Frequency Stability:

Better than ±4 ppm (-10 °C to +50 °C) (SSB/CW/AM)
Better than ±{1 kHz +4 ppm} (FM)

Power Requirements:

DC 13.8V ±10%, Negative Ground

Current Consumption:

Receive (Squelched): 1.2A, Receive (Max. Audio): 1.6A

Specifications

Receiver

Sensitivity:	SSB/CW	AM-N	FM
100 kHz – 150 kHz:	–	–	–
150 kHz – 250 kHz [*] :	5 μ V	40 μ V	–
250 kHz – 1.8 MHz [*] :	4 μ V	32 μ V	–
1.8 – 28 MHz [*] :	0.25 μ V	2 μ V	–
28 – 30 MHz:	0.25 μ V	2 μ V	0.50 μ V
50 – 54 MHz:	0.20 μ V	2 μ V	0.50 μ V
144/430 MHz:	0.125 μ V	2 μ V	0.20 μ V

Above specifications are worst-case.

SSB/CW/AM-N figures are for 10 dB S/N, 12 dB SINAD on FM

**: IPO off*

Squelch Sensitivity:	SSB/CW/AM	FM
1.8 – 28 MHz:	2.5 μ V	–
28 – 30 MHz:	2.5 μ V	0.32 μ V
50 – 54 MHz:	1.12 μ V	0.20 μ V
144/430 MHz:	0.8 μ V	0.16 μ V

Intermediate Frequencies:	
1st IF:	68.985 MHz (SSB/CW/FM/Digital) 67.980 MHz (W-FM)
2nd IF:	11.705 MHz (SSB/CW/FM/Digital) 10.700 MHz (W-FM)
3rd IF:	455 kHz (FM)

Image Rejection:	
	Better than 70 dB (1.8 – 30 MHz, 50 – 54 MHz) Better than 60 dB (144 – 148 MHz, 430 – 440 MHz)

IF Rejection:	
	Better than 70 dB (1.8 – 30 MHz) Better than 60 dB (50 – 54 MHz, 144 – 148 MHz, 430 – 440 MHz)

Selectivity (–6/–60 dB):	
SSB/CW:	2.2 kHz/5.2 kHz
CW:	450 Hz/1.8 kHz (Optional XF-117C installed)
CW-N:	250 Hz/1.2 kHz (Optional XF-117CN installed)
AM:	5.2 kHz/18 kHz (Optional XF-117A installed)
FM:	15 kHz /25 kHz (–6/–50 dB)

Audio Output:	
	At least 1.5W into 8 Ω @ 10% THD

Audio output impedance:	
	4 Ω – 8 Ω

Specifications are subject to change without notice, and are guaranteed within amateur bands only.

Plug/Connector Pinout Diagrams



Accessories & Options

SUPPLIED ACCESSORIES

Hand Microphone **MH-42B6JS** or **MH-36B6JS** (depending on transceiver version)

Power Cable T9021925
Spare Fuse 25A (Q0000074)
Mobile Mounting Bracket **MMB-48**
Operating Manual

AVAILABLE OPTIONS

Separation Kit **YSK-100**
External Automatic Antenna Tuner **FC-20**
Active-Tuning Antenna System **ATAS-100**
Antenna Base Kit **ATBK-100**
High-Stability Reference Oscillator **TCXO-8**
External AC Power Supply (30A) **FP-1030A**
Compact Power Supply (23A) **FP-1023A** (U.S.A. only)
Solid-State Linear Amplifier **VL-1000**
CW Filter (300 Hz) **XF-117CN**
CW Filter (500 Hz) **XF-117C**
AM Filter (6 kHz) **XF-117A**
Interface Cable (for VL-1000) **CT-58**
Mobile Remote Head Bracket **MMB-62**
Quick-Release Mobile Bracket **MMB-67**
CTCSS Decoder Unit **FTS-27**
DTMF Microphone **MH-36B6JS**
Hand Microphone **MH-42B6JS**
Packet Interface Cable **CT-39**
CAT Interface Cable **CT-62**

Installation

INSTALLING THE MICROPHONE AND FRONT PANEL

1. Insert the microphone's plug into the recessed jack on the transceiver, as shown in the drawing.
2. You can position the microphone cable so as to cause it to exit from the side or the bottom of the transceiver. Just route the cable into the appropriate channel provided, as shown in the illustration.
3. Install the front panel by sliding it into the position shown; you will hear a "click" when the panel locks into place.
4. To remove the front panel, use your right thumb to pry open (slightly) the latch on the right-hand of the panel, then slide the panel outward and away from the transceiver.

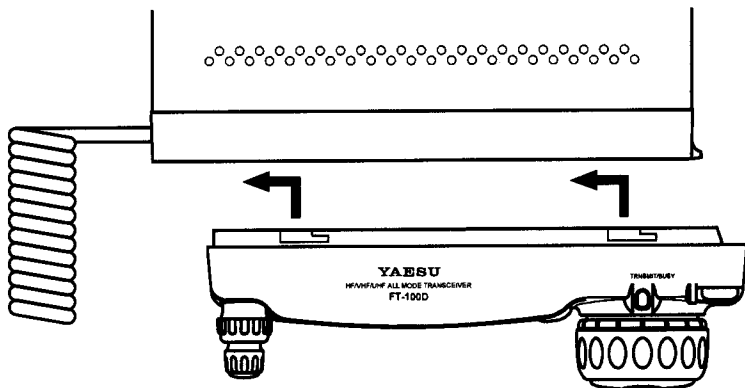
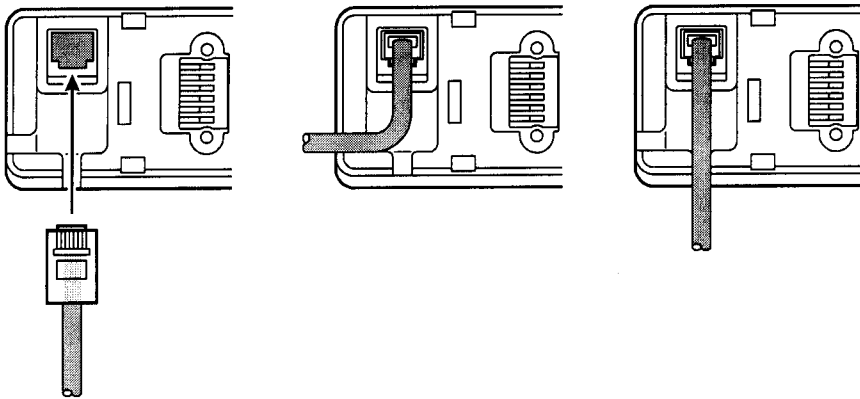

Installation

POWER CONNECTIONS

The DC power connector for the FT-100 must only be connected to a DC source providing 13.8 Volts DC ($\pm 10\%$), and capable of at least 22 Amperes of current. Always observe proper polarity when making DC connections:

**The RED DC power lead connects to the POSITIVE (+) DC terminal; and
The BLACK DC power lead connects to the NEGATIVE (-) DC terminal.**

For base station installations, Yaesu recommends the use of the FP-1023, FP-1025, or FP-1030A AC power supplies. Other models of power supplies may be used with the FT-100, but the 13.8V DC input voltage, 22-Ampere current capability, and DC cable polarity guidelines described above must be strictly followed.

Note that other manufacturers may use the same type of DC power connections as does your FT-100 transceiver, but the wiring configuration of the other manufacturer's plug may be different from that specified for your transceiver. Serious damage can be caused if improper DC connections are made; consult with a qualified service technician when in doubt.

In mobile installations, noise pickup may be minimized by connecting the DC cable directly to your vehicle's battery, rather than to the ignition switch or "accessory" circuitry. Direct connection to the battery also provides the best voltage stability.

Tips for Successful Mobile Installations:

- Before connecting the DC cable to the battery, measure the voltage across the battery terminals with the engine running fast enough to show a charge. If the voltage is above 15 Volts, the vehicle's voltage regulator should be adjusted to reduce the charging voltage to 14 Volts or lower.
- Route the DC cable as far away from the ignition cables as possible.
- If the DC cable is not long enough, use #12 AWG (minimum) stranded, insulated wire to extend it. Be certain to solder the connections at the splice securely, and provide ample insulation for the soldered splice (heat shrink tubing plus black electrical tape work well).
- Check the battery terminal connections frequently to be sure they are tight and not corroded.

Caution

Permanent damage can result if improper supply voltage, or reverse-polarity voltage, is applied to the FT-100. The Limited Warranty on this transceiver does not cover damage caused by application of AC voltage, reversed polarity DC, or DC voltage outside the specified range of 13.8V $\pm 10\%$. *Never attempt to connect the FT-100 to a 24 Volt battery system.*

When replacing fuses, be certain to use a fuse of the proper rating. The FT-100 requires a 25A fast-blow fuse.

POWER CONNECTIONS

FT- 100

ANI?

GROUNDING

The provision of an effective ground system is important in any successful communications station. A good ground system can contribute to station efficiency in a number of ways:

- It can minimize the possibility of electrical shock to the operator.
- It can minimize RF currents flowing on the shield of the coaxial cable and the chassis of the transceiver which may cause interference to nearby home entertainment devices or laboratory test equipment.
- It can minimize the possibility of erratic transceiver operation caused by RF feedback or improper current flow through logic devices.

An effective earth ground system may take several forms; for a more complete discussion, see an appropriate RF engineering text. The information presented below is intended only as a guideline.

Inspect the ground system – inside the station as well as outside – on a regular basis so as to ensure maximum performance and safety.

Mobile Station Grounding

Although satisfactory grounding in most installations will be achieved via the DC cable's negative lead and the antenna system's coaxial cable shield, it is often recommended that you provide a direct ground connection to the vehicle chassis *at the mounting location of the transceiver* (installation using the MMB-48 Mobile Bracket will accomplish this, if the MMB-48 itself is mounted to the vehicle's chassis). Due to unexpected resonances which may naturally occur in any location, improper communication system performance may result from insufficient grounding. These symptoms may include:

- RF feedback (resulting in distortion on your transmitted signal);
- Unintended frequency change;
- Blinking or blanking of the frequency display;
- Noise pickup; and/or
- Loss of memory.

Note that these conditions may occur in *any* communications installation. The FT-100 includes extensive filtering designed to minimize the chance of such problems; however, random currents set up by insufficient RF grounding can nullify such filtering. Bonding the rear panel Ground lug of the FT-100 transceiver to the vehicle or vessel's ground system should clear up any such difficulties.

Yaesu does not recommend the use of "on glass" mobile antennas unless the shield of the coaxial cable is securely grounded near the feedpoint of the antenna. Such antennas frequently are responsible for the ground-related difficulties described above.

GROUNDING

Base Station Earth Grounding

Typically, the ground connection consists of one or more copper-clad steel rods, driven into the ground. If multiple ground rods are used, they should be configured in a "V" configuration, and bonded together at the apex of the V which is nearest the station location. Use a heavy, braided cable (such as the discarded shield from type RG-213 coaxial cable) and strong cable clamps to secure the braided cables to the ground rods. Be sure to weatherproof the connections to ensure many years of reliable service. Use the same type of heavy, braided cable for the connections to the station ground bus (described below).

Do not use gas line pipes in an attempt to provide a ground connection! To do so creates a serious risk of explosion!!

Inside the station, a common ground bus consisting of a copper pipe of at least 25 mm (1") diameter should be used. An alternative station ground bus may consist of a wide copper plate (single-sided circuit board material is ideal) secured to the bottom of the operating desk. Grounding connections from individual devices such as transceivers, power supplies, and data communications devices should be made directly to the ground bus using a heavy, braided cable.

... devices to another and thence to the

[REDACTED]

[REDACTED]

[REDACTED]

Installation

ANTENNA CONSIDERATIONS

The antenna systems connected to your FT-100 transceiver are, of course, critically important in ensuring successful communications. The FT-100 is designed for use with any antenna system providing a 50Ω resistive impedance at the desired operating frequency. While minor excursions from the 50Ω specification are of no consequence, the power amplifier's protection circuitry will begin to reduce the power output of there is more than a 50% divergence from the specified impedance (less than 33Ω or greater than 75Ω , corresponding to a Standing Wave Ratio (SWR) of 1.5:1).

Two antenna connector "pigtailes" are provided on the rear panel of the FT-100. The "**ANTENNA 1**" connection is used for HF and 50 MHz, while the "**ANTENNA 2**" connector is used for 144 MHz and 430 MHz.

Guidelines for successful base and mobile station installations are shown below.

Mobile Antenna Installations

Mobile antennas for the HF bands, with the possible exception of those designed for 28 MHz, display very high "Q" due to the fact that they must be physically shortened, then resonated using a loading coil. Additional system bandwidth may be realized using the Yaesu **FC-20** Automatic Antenna Tuner, which will present a 50Ω impedance to your transceiver on the 1.8 ~ 50 MHz bands so long as the SWR on the coaxial line connected to the **FC-20** is below 3:1.

On the VHF and UHF bands, coaxial line losses increase so rapidly in the presence of SWR that we recommend that all impedance matching to 50Ω be performed at the antenna feedpoint.

Yaesu's Active-Tuned Antenna System (**ATAS-100**) is a unique HF/VHF/UHF mobile antenna system, which provides automatic tuning when used with the FT-100. See page 62 for full details on the **ATAS-100**.

For VHF/UHF weak-signal (CW/SSB) operation, remember that the antenna polarization standard for these modes is horizontal, not vertical, so you must use a loop or otherwise horizontally-polarized antenna so as to avoid cross-polarization loss of signal strength (which can be 20 dB or more!). On HF, signals propagated via the ionosphere develop mixed polarizations, so antenna selection may be made strictly on mechanical considerations; vertical antennas are almost always utilized on HF for this reason.

ANTENNA CONSIDERATIONS

Base Station Antenna Installations

When installing a “balanced” antenna such as a Yagi or dipole, remember that the FT-100 is designed for use with an (unbalanced) coaxial feedline. Always use a balun or other balancing device so as to ensure proper antenna system performance.

Use high-quality 50Ω coaxial cable for the lead-in to your FT-100 transceiver. All efforts at providing an efficient antenna system will be wasted if poor quality, lossy coaxial cable is used. Losses in coaxial lines increase as the frequency increases, so a coaxial line with 0.5 dB of loss at 7 MHz may have 6 dB of loss at 432 MHz (thereby consuming 75% of your transceiver’s power output!). As a general rule, smaller-diameter coaxial cables tend to have higher losses than larger-diameter cables, although the precise differences depend on the cable construction, materials, and the quality of the connectors used with the cable. See the cable manufacturers’ specifications for details.

For reference, the chart below shows approximate loss figures for typically- available coaxial cables frequently used in HF installations.

Loss in dB per 30m (100 feet)
for Selected 50Ω Coaxial Cables

CABLE TYPE	Loss		
	1.8 MHz	28 MHz	432 MHz
RG-58A	0.55	2.60	>10
RG-58 Foam	0.54	2.00	8.0
RG-8X	0.39	1.85	7.0
RG-8A, RG-213	0.27	1.25	5.9
RG-8 Foam	0.22	0.88	3.7
Belden 9913	0.18	0.69	2.9
7/8" "Hardline"	<0.1	0.25	1.3

Loss figures are approximate; consult cable manufacturer’s catalogs for complete specifications.

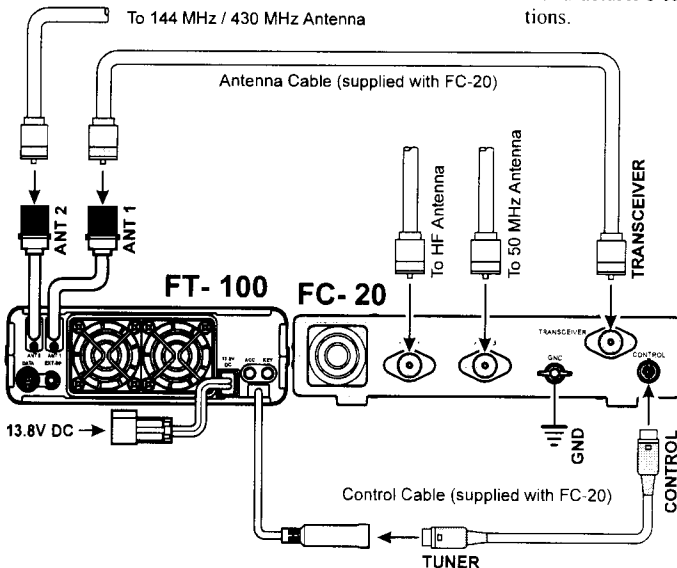

Installation

ANTENNA CONSIDERATIONS

Always locate antennas such that they can *never* come in contact with outdoor power lines in the event of a catastrophic support or power-pole structural failure. Ground your antennas' support structure(s) adequately, so as to dissipate energy absorbed during a lightning strike. Install appropriate lightning arrestors in the antenna coaxial cables (and rotator cables, if rotary antennas are used).

In the event of an approaching electrical storm, disconnect all antenna lead-in, rotator cables, and power cables *completely* from your station **if the storm is not immediately in your area**. Do not allow disconnected cables to touch the case of your FT-100 transceiver or accessories, as lightning can easily jump from the cable to the circuitry of your transceiver via the case, causing irreparable damage. If a lightning storm is in progress in your immediate area, do not attempt to disconnect the cables, as you could be killed instantly if lightning should strike your antenna structure or a nearby power line.

If a vertical antenna is utilized, be certain that humans and/or pets and



ANTENNA CONSIDERATIONS

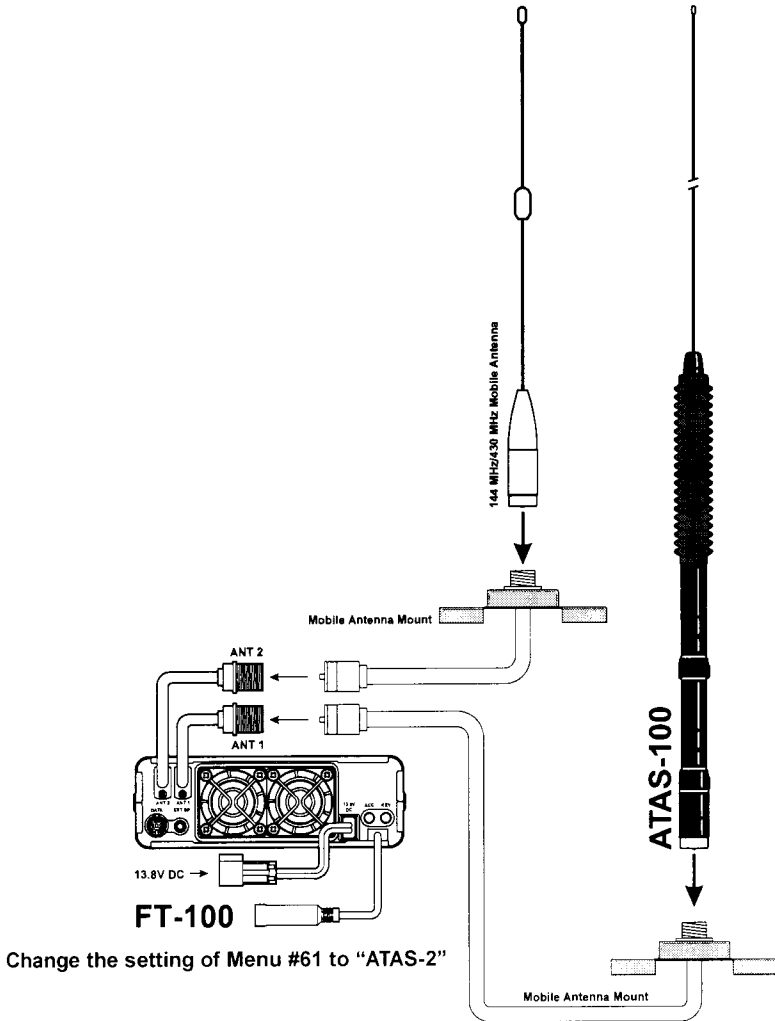

Installation

RF FIELD EXPOSURE

This transceiver is capable of power output in excess of 50 Watts, so customers in the United States *may* be required to demonstrate compliance with Federal Communications Commission (FCC) regulations concerning maximum permissible exposure to radio frequency energy. Compliance is based on the actual power output used, feedline loss, antenna type and height, and other factors which can only be evaluated as a system.

Information regarding these regulations may be available from your Dealer, your local radio club, from the FCC directly (press releases and other information can be found on the FCC's site on the World Wide Web at <<http://www.fcc.gov>>), or from the American Radio Relay League, Inc. (225 Main St., Newington CT 06111 or <<http://www.arrl.org>>).

Although there is negligible radio frequency (RF) leakage from the FT-100 transceiver itself, its antenna system should be located as far away from humans and animals as practicable, so as to avoid the possibility of shock due to accidental contact with the antenna or excessive long-term exposure to RF energy. During mobile operation, do not transmit if someone is standing adjacent to your antenna, and use the lowest power possible.

Never stand in front of an antenna (during testing or operation) when RF power is applied, *especially* in the case of 430 MHz directional arrays. The 20 Watt power output supplied by the FT-100, combined with the directivity of a beam antenna, can cause immediate heating of human or animal tissues, and may cause other undesirable medical effects.

ACCESSORY INTERFACING

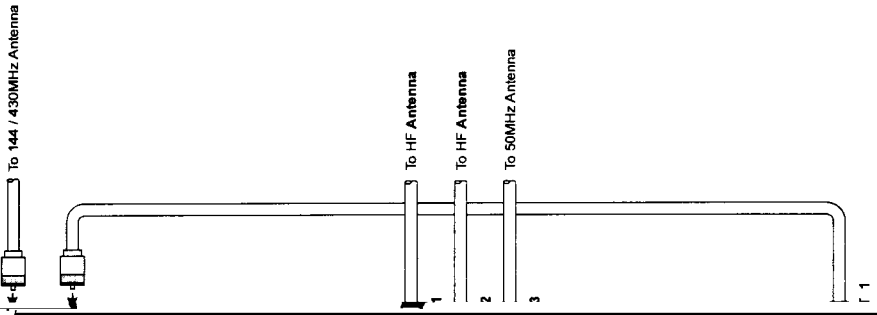

Installation

ACCESSORY INTERFACING

AFSK TNC Connections (for RTTY, Packet, etc.)

The FT-100 is easy to connect to most all Terminal Node Controllers (TNCs) or other digital modem units used for RTTY, HF Packet, and other digital modes which utilize USB or LSB as the fundamental operating mode.

Audio Frequency Shift Keying (AFSK) operation for HF Packet, AMTOR, 300 bps

Packet, etc. is provided via the rear-panel **DATA** jack. Pin 1 of this jack accepts AFSK input from the TNC's "TX Audio" line. Pin 3 is used for PTT control (the TNC closes this line to ground to cause the FT-100 to transmit). Pin 5 is used for "RX Audio" which is sent to the TNC for decoding. Pin 2 is used for Ground for all lines.

The optimum levels/impedances are shown below:

Pin 1 (Data In): 40 mV @ 10 k Ω

Pin 5 (Data Out): 300 mV @ 10 k Ω

When operating on AFSK, the microphone is automatically disconnected when the radio's microphone detects PTT control from the **DATA** jack. Therefore, it is not necessary to

ACCESSORY INTERFACING

FM Packet TNC Interfacing

The rear-panel **DATA** jack is also used for connections to a TNC for FM Packet work. The FM Packet connections are in accordance with a standard adopted by many Amateur-product manufacturers. However, we recommend that you verify the connections to any cable you may already own by comparing it to the pictorial below.

The FT-100's **DATA** jack connections are optimized for the data transmission and reception speed in use. In accordance with the aforementioned industry standards, the signal levels, impedances, and bandwidths are significantly different on 9600 bps as opposed to 1200 bps. If your TNC does not provide multiple lines to accommodate such optimization, you may still be able to utilize your TNC if it is designed for multiple-radio use; connect the TNC "Radio 1" port to the 1200 bps lines on the FT-100, and the "Radio 2" port to the 9600 bps lines.

For ease in making connections to your packet TNC, the optional **CT-39** Packet Cable is available from your Yaesu dealer. With reference to the "**DATA Jack Pin Connections**" chart and the **DATA** jack pinout on page 4, you may connect your TNC in minutes using the color-coded information provided.

Most modern TNCs use a PLL-type DCD (Data Carrier Detect) circuit, so you will generally not need to connect anything to the Squelch Control line (Pin 6) of the **DATA** jack.

Note that 9600 bps packet transmit-deviation adjustment is very critical to successful operation, and can only be accomplished using a calibrated deviation meter (such as that

DATA Jack Pin Connections

Pin	Label	Notes
1	PKD	Packet Data Input Impedance: 10 k Ω Max. Input Level: 40 mV pp @ 1200bps 2.0 V pp @ 9600bps
2	GND	Signal Ground
3	PTT	Ground on Transmit
4	RX9600	9600bps Packet Data Out Impedance: 10 k Ω Max. Output Level: 500 mV pp
5	RX1200	1200bps Packet Data Out Impedance: 10 k Ω Max. Output Level: 300 mV pp
6	SQL	Squelch Control Squelch Open: +5V Squelch Closed: 0V

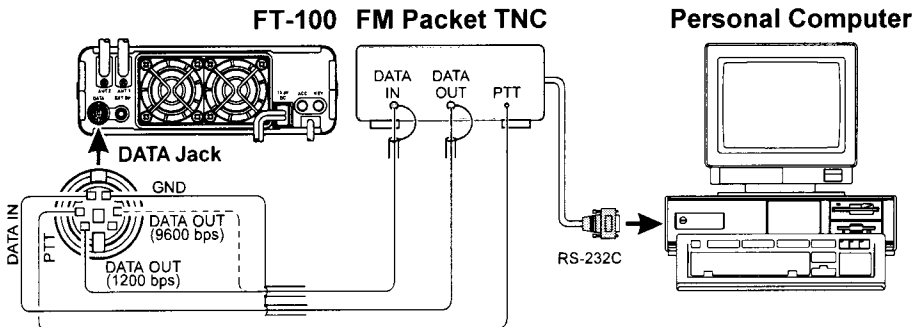

Installation

ACCESSORY INTERFACING

found on an FM Service Monitor used in a communications service center). In most cases, the Packet Data Input level (set via a potentiometer inside the TNC) must be adjusted to provide a deviation of ± 2.75 kHz (± 0.25 kHz). Check with your packet node's sysop if you have any questions about the appropriate deviation level for your network.

The setting of the 1200 bps Packet Data Input level is much less critical, and satisfactory adjustment to the optimum ($\pm 2.5 \sim \pm 3.5$ kHz) deviation can usually be done "by ear" by adjusting the TNC's 1200 bps TX Audio Level potentiometer so that the outgoing packets (as monitored on a separate VHF or UHF receiver) are slightly lower than the level of your speech. If you have the optional **MH-36B6JS** DTMF Microphone, set your TNC's tone output to be about the same level as that of the DTMF tones produced by the **MH-36B6JS**.

The "RX 1200" and "RX 9600" lines are fixed-level audio outputs, not affected by the setting of the **AF** (GAIN) control.

CW Key/Keyer Connections

All commonly-available keyer paddles should work perfectly with the built-in Electronic Keyer. The wiring configuration for the paddle is shown below.

For straight-key operation, only the tip and shaft connections are used.

Note: Even when using a straight key, you must use a three-conductor ("stereo") plug. If a two-conductor plug is used, the key line will be constantly shorted to ground.

When using an external electronic keyer, be absolutely certain that it is configured for "positive" keying, not "negative" or "grid block" keying. The "key-up" voltage of the FT-100 is +5V, and the "key-down" current is only about 1 mA.

For CW automated keying using a personal computer, with an external memory keyer providing for manual sending, it usually is possible to connect the keyed lines together via a "Y" connector. Check with the documentation accompanying your keyer and your contest/DX software for any cautions which need to be observed.

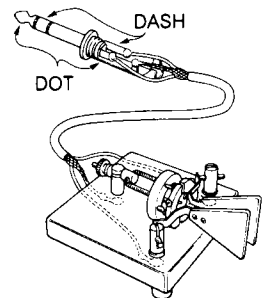
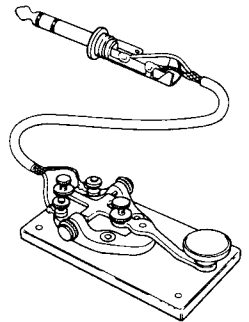

Installation

ACCESSORY INTERFACING

Receiver Accessories (Tape Recorder, WeatherFax Demodulator, etc.)

Connection of a tape recorder, WeatherFax demodulator, or other such receiver accessory is easily accomplished by using the **DATA** jack's **DATA OUT** (1200 bps) terminal (Pin 5) and Ground (Pin 2). The audio output is fixed at 100 mV, with an impedance of 600 Ω .

CONNECTION OF HEADPHONES

The FT-100's extremely compact size does not permit inclusion of a headphone jack. Direct connection of 4 Ω or 8 Ω headphones to the Speaker jack, however, could cause hearing damage, due to the high level of audio output available at that jack.

To connect headphones to the Speaker jack, build a small attenuator circuit into a small adapter box. Connect a 100 Ω $\frac{1}{2}$ W resistor in series with the headphone line, and a 10 Ω $\frac{1}{2}$ W resistor shunt to the shield (ground).

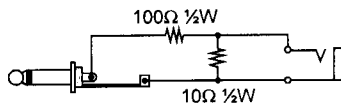

ADJUSTING THE FRONT FEET

Front Panel Controls and Switches

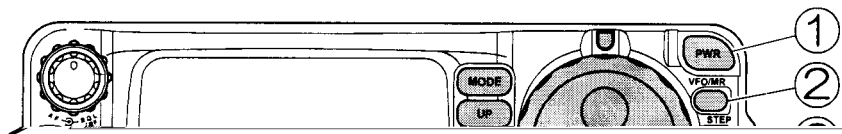

Front Panel Controls and Switches

⑤ LOCK Key

Pressing this key locks the **MAIN DIAL**, so as to prevent accidental frequency change.

⑥ MAIN DIAL

This is the main tuning dial for the transceiver. It is used both for frequency tuning as well as “MENU” setting in the FT-100.

⑦ FUNC Key

The “**Function**” key is used to select one of the nine operations available on each of the **[A]**, **[B]**, **[C]**, or **[D]** keys. These keys are located below the LCD (display).

⑧ MODE Key

Pressing this key repeatedly allows selection of the operating mode. The selections available are:

SSB (LSB or USB) → CW → AM → FM → SSB (LSB or USB) ...

Pressing *and holding in* this key for ½ second allows toggling of modes within a mode group (**LSB ⇄ USB**, **CW ⇄ CW-R [Reverse]**, **AM ⇄ DIG**, and **FM ⇄ W[Wide]-FM**).

⑨ UP/DWN Keys

Pressing one of these keys momentarily will cause the frequency to be moved up or down by one Amateur band.

⑩ DSP Key

Pressing this key momentarily provides instant access to Operating Function Row 9, which contains the command keys for the receiver’s **Digital Signal Processing** system. The available functions will appear as the functions displayed above the **[A]** ~ **[D]** keys, described below.

⑪ FUNC Key

These four keys select many of the most important operating features of the FT-100. Above each of the **[A]** ~ **[D]** keys (along the bottom of the LCD) is a label describing the current function of that key; pressing the **FUNC** key repeatedly scrolls the display through nine rows of functions available for use via the **[A]** ~ **[D]** keys. The available features are shown in the chart below.

Front Panel Controls and Switches

Func	[A] Key	[B] Key	[C] Key	[D] Key
1	A/B Press the [A] key to switch between VFO-A and VFO-B on the display.	A=B Press and hold the [B] key for ½ second to copy the contents of VFO-A into the VFO-B register, so that the two VFOs' contents will be	SPL Press the [C] key momentarily to activate SPLIT frequency operation between VFO-A and VFO-B.	QMB Pressing the [D] key repeatedly recalls the QMB Memories sequentially. Pressing the [VFO/MR] key and <i>holding it in</i>

Front Panel Controls and Switches

Func	[A] Key	[B] Key	[C] Key	[D] Key
7	<p>MTR</p> <p>Press the [A] key to select the display function of the Meter in the transmit mode (ALC or SWR indication).</p>	<p>TUN</p> <p>Press the [B] key to activate the optional FC-20 Automatic Antenna Tuner or ATAS-100 Active-Tuning Antenna System.</p> <p>Press and hold the [B] key for ½ second to initiate tuner or antenna retuning.</p>	<p>PRO</p> <p>Press the [C] key to activate the Speech Processor (SSB/AM modes only).</p> <p>Press and hold the [C] key for ½ second to recall MENU #27 (for setting the compression level).</p>	<p>VOX</p> <p>Press the [D] key to enable the VOX (voice-operated transmitter switching) system in the SSB, AM, and FM modes.</p> <p>Press and hold the [D] key for ½ second to recall MENU #54 (to set the VOX Gain level).</p>
8	<p>WRI</p> <p>Press and hold the [A] key for ½ second to enable the storage of a CW message (50 characters maximum length).</p>	<p>PLY</p> <p>Press the [B] to send the message recorded via the [A] key.</p>	<p>BK</p> <p>Press the [C] key to activate CW Break-in operation.</p> <p>Press and hold the [C] key for ½ second to recall MENU #51 (for selecting Full- or Semi-Break-In CW).</p>	<p>KYR</p> <p>Press the [D] key to activate the built-in Electronic Keyer.</p> <p>Press and hold the [D] key for ½ second to recall MENU #46 (for setting the Electronic Keyer mode).</p>
9	<p>DNR</p> <p>Press the [A] key to activate the DSP Noise Reduction system.</p> <p>Press and hold the [A] key for ½ second to recall MENU #17 (to select one of the four available Noise Reduction settings).</p>	<p>DNF</p> <p>Press the [B] key to activate the DSP's Auto Notch filter.</p>	<p>DBP</p> <p>Press the [C] key to activate the DSP's receiver Bandpass Filter.</p> <p>In the SSB, AM, FM and AFSK modes, press and hold the [C] key for ½ second to recall MENU #18 to adjust the high-frequency cutoff of the DSP Bandpass Filter via the SELECT knob.</p> <p>In the CW mode, press and hold the [C] key for ½ second to recall MENU #20 (for setting the CW Bandwidth).</p>	<p>—</p> <p>No function.</p>

* The Operating Function number in this column does not appear on the LCD.

Front Panel Controls and Switches

12

40



Microphone Switches

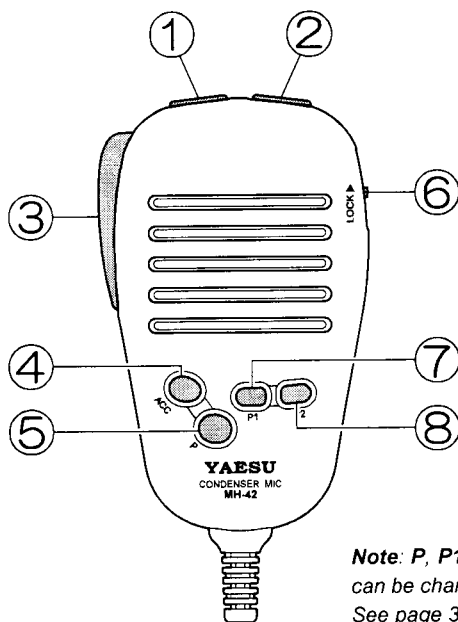

Note: P, P1, and P2 button functions can be changed via the MENU system. See page 37.

① **DWN** Button

Press this button to tune downward in the current step increment, hold this button in to start scanning toward a lower frequency.

② **UP** Button

Press this button to tune upward in the current step increment, hold this button in to start scanning toward a higher frequency.

③ **PTT** Switch

Press this switch to transmit, and release it to receive.

④ **ACC** Button (HOME)

Pressing button key recalls a favorite "HOME" frequency memory.

⑤ **P** Button (VFO/MR)

Pressing this button switches frequency control between the VFO and Memory Systems.

⑥ **LOCK** Switch

Slide this switch upward to lock (disable) the microphone buttons.

⑦ **P1** Button (BAND Down)

Pressing this button will cause the frequency to be switched to the next-lowest band.

⑧ **P2** Button (BAND UP)

Pressing this button will cause the frequency to be switched to the next-highest band.

Rear Panel Connectors

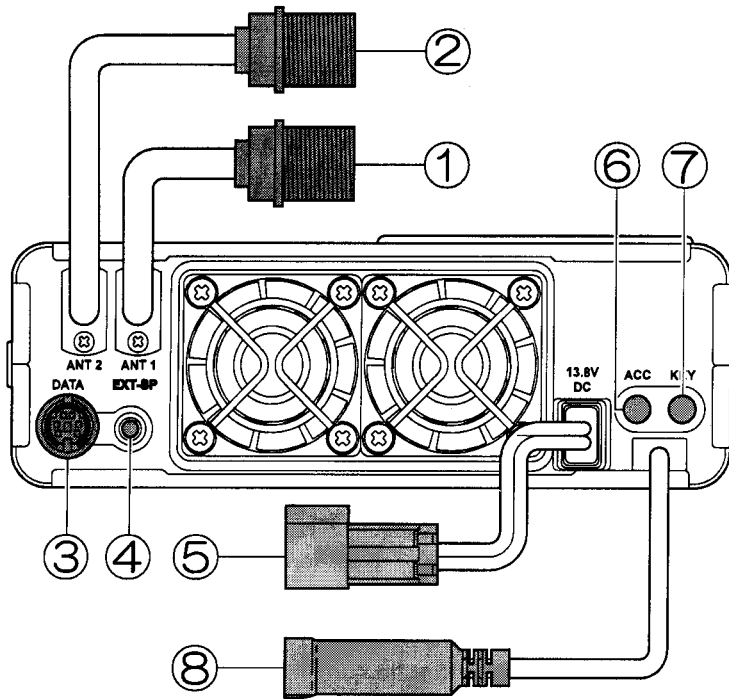

① ANTENNA 1 Cable

Connect your HF and/or 50 MHz antenna's 50Ω coaxial cable to this M-type ("SO-239") connector.

② ANTENNA 2 Cable

Connect your 144 and/or 430 MHz antenna's 50Ω coaxial cable to this connector.

③ DATA Jack

This six-pin mini-DIN jack accepts AFSK or FSK input from a Terminal Node Controller (TNC) or Terminal Unit (TU); it also provides fixed-level Receiver Audio Output, Push-To-Talk (PTT), and Ground lines.

④ EXT SP Jack

This 3.5-mm, 2-pin jack provides variable audio output for an external speaker. The audio output impedance at this jack is 4Ω ~ 16Ω, and the level varies according to the setting of the front panel's **AF** control.

Rear Panel Connectors

⑤ **13.8 VDC** Cable Pigtail

This is the DC power supply connection for the transceiver. Use the supplied DC cable to connect this pigtail to the car battery or base station DC power supply, which must be capable of supplying at least 25 Amperes (continuous duty). Make certain that the **RED** lead connects to the **Positive** side of the power source, and that the **BLACK** lead connects to the **Negative** side of the power source.

⑥ **ACC** Jack

This 3.5-mm 3-pin jack accepts external ALC (Automatic Level Control) voltage from a linear amplifier on the tip connection, and provides TX/RX control to a linear amplifier (closure to ground on transmit) on the ring connection. The main shaft is the ground return.

⑦ **KEY** Jack

This 3.5-mm 3-pin jack is used for connection to a CW keyer paddle or a straight key. Use only a 3.5-mm *stereo* plug for these connections.

⑧ **BAND DATA** Cable Pigtail

This 8-pin mini-DIN jack is used for connection to the **FC-20** External Automatic Antenna Tuner or **ATAS-100** Active-Tuning Antenna System. It is also used for interfacing to a personal computer for control of the FT-100 using the **CAT** System, and for interconnection to the **VL-1000** Linear Amplifier.

Basic Operation



Hi! I'm R. F. Radio, and I'll be helping you along as you learn the many features of the FT-100. I know you're anxious to get on the air, but I encourage you to read the "Operation" section of this manual as thoroughly as possible, so you'll get the most out of this fantastic new transceiver. Now ... let's get operating!

BEFORE YOU START

1. Be certain that power supply connections have been securely made, and that the proper polarity has been observed.
 2. Be certain that your antennas have been connected to the correct cable pigtails on the rear of the transceiver.
-

OPERATION QUICK START

The basic steps required to begin operation are:

1. Turn the transceiver on.
 2. Set the band on which you wish to operate.
 3. Set the operating mode on which you wish to operate.
 4. Adjust the audio volume level.
 5. Adjust the operating frequency using the **MAIN DIAL**.
-

TURNING THE TRANSCEIVER ON AND OFF

1. To turn the FT-100 on, press and hold in the **PWR** switch for ½ second.
2. To turn the transceiver off, again press and hold in the **PWR** switch for ½ second.



*By making you press the **PWR** switch for ½ second, the FT-100 makes it more difficult for you accidentally to cut power by just bumping the switch with your finger.*

AMATEUR BAND SELECTION

Press either the [UP] or [DWN] key to move to the next higher or lower Amateur band, respectively.

As you do this, you may observe the operating mode changing. This is normal; default "startup" modes are pre-programmed for each band, for your convenience. These modes may be changed, of course, per the next section.

MODE SELECTION

1. Press the **[MODE]** key repeatedly to toggle among the four “Macro” settings for the operating mode:
SSB (LSB or USB) → CW → AM → FM → SSB (LSB or USB) ...
When operating on frequencies *below 10 MHz*, the default SSB mode is **LSB**; *above 10 MHz*, the default SSB mode is **USB**.
2. To reverse SSB modes, press and hold in the **[MODE]** key for ½ second to toggle between **LSB ⇌ USB**.
3. Similarly, pressing and holding in the **[MODE]** key while in the **CW** mode allows selection of either the **CW ⇌ CW-R** (Reverse) mode.
4. Pressing and holding in the **[MODE]** key for ½ second while in the **AM** mode allows selection of either **AM ⇌ DIG** (Digital).
5. Pressing and holding in the **[MODE]** key while on **FM** allows selection of either **FM** or **W-FM** (Wide FM).



The operating mode will be preserved on each band's VFO, so that when you return to a particular band, you will return to the mode you were using the last time you operated on that band.

SETTING THE AUDIO VOLUME LEVEL

1. Rotate the **AF** control to set a comfortable listening level.
2. When operating in the “DIG” mode, you may set the **AF** control to any comfortable setting, or even all the way off, because the output from the **DATA** jack is a fixed-level audio signal.



Start with the AF control set fully counter-clockwise, especially when using FM (the background noise on FM can be surprisingly loud)!

SETTING THE OPERATING FREQUENCY

1. Rotate the **MAIN DIAL** to set the frequency. Clockwise rotation of the **MAIN DIAL** increases the operating frequency.
2. You may also use the **SELECT** knob to adjust the operating frequency. In the VFO mode, the **SELECT** knob functions as a “channelized” tuning dial, allowing quick excursions around the band.



Both the synthesizer's tuning steps and the tuning rate (the number of steps per rotation of the MAIN DIAL) can be adjusted. See page 35 for details.

Receiver Operation

The FT-100 includes a wide variety of features which may be used to enhance reception.

Before you explore these features, it is important to understand the proper utilization of the **OPERATING FUNCTION SELECTOR** key (**[FUNC]**) and the **[A]**, **[B]**, **[C]**, and **[D]** keys, which often are used to activate or change various features of the FT-100 in everyday operation.

OPERATING FUNCTION SELECTOR (**[FUNC]** KEY)

Full access to the many full range of features provided on the FT-100 would require many more controls and switches than could possibly fit on the tiny front panel of the transceiver. Therefore, the FT-100 utilizes a flexible **OPERATING FUNCTION SELECTOR** key, labeled **[FUNC]**, to provide access to these many features via the **[A]**, **[B]**, **[C]**, and **[D]** keys.

The **[FUNC]** key must be pressed correctly, as there are two modes of **[FUNC]** key operation which are often used.

- Pressing the **[FUNC]** key *momentarily* causes this key to serve as the **OPERATING FUNCTION SELECTOR**.
- Pressing *and holding* in the **[FUNC]** key for ½ second activates the “MENU” mode, used to customize many aspects of the transceiver’s configuration. The MENU mode is detailed in the chapter beginning on page 82.

*Basic Operation of the **[FUNC]** Key*

1. Press the **[FUNC]** key momentarily. Note that the labels on the LCD just above the **[A]** ~ **[D]** keys will change. Repeatedly pressing the **[FUNC]** key will scroll the LCD through the *nine* rows of features provided via the **OPERATING FUNCTION SELECTOR**.
2. Once the row containing the desired feature is located, press the **[A]**, **[B]**, **[C]**, or **[D]** key to select the desired function within that row.
3. Next, depending on the feature being utilized, you may be instructed to press the same key again to toggle the current setting to a new state (e.g. from OFF to ON).



*If you don't see the operating functions appear on the LCD, you may have held the **[FUNC]** key in too long – putting you in the “MENU” mode. Press **[FUNC]** again to escape and start over.*

ICON DISPLAY

The left side of the FT-100’s LCD includes a handy Icon display field, which alerts you to many aspects of the transceiver’s current operating status.

Receiver Operation

BANDWIDTH SELECTION (SSB/CW/AM/DIG MODES)

1. Press the **[FUNC]** key, as necessary, until Operating Function Row 6 [6.0, 2.4, 500, 300] appears on the display.
2. Now press the **[A]**(6.0) key to select 6.0 kHz, the **[B]**(2.4) key to select 2.4 kHz, the **[C]**(500) key to select 500 Hz, or the **[D]**(300) key to select 300 Hz bandwidth.

These bandwidth selection options are displayed immediately above the **[A]**, **[B]**, **[C]**, and **[D]** keys along the bottom edge of the display. Note that the **[B]** bandwidth (2.4 kHz) is installed at the factory, while the other bandwidths require the installation of optional filters.



Only the 6.0 kHz and 2.4 kHz modes are usable for AM reception, as the 500 Hz and 300 Hz bandwidths are much too narrow to pass AM signals.

FREQUENCY SYNTHESIZER STEPS

The FT-100 uses a “frequency synthesizer” tuning system, which is capable of both coarse and ultra-fine steps. A wide variety of synthesizer steps is available, so allow you the flexibility to cope with different operating situations.

The tuning steps will change as you change operating modes. This capability provides greater convenience during frequency adjustments, as the need for tuning precision is very different when operating on CW or DIG(AFSK) as compared to FM.

Press the **[STEP]** key momentarily to change the tuning steps of the **MAIN DIAL** and/or the **SELECT** knob.

In the case of the **MAIN DIAL** the **[STEP]** key toggles only the tuning steps utilized in the

SSB, CW, and DIG(AFSK) modes:

1.25 → 2.5 → 5 → 10 → 25 → 50 → 100 → 1.25 ... (Hz)

(The AM/FM steps are fixed at 100 Hz/step in AM/FM, 1 kHz/step in W-FM)

Receiver Operation

TUNING SPEED SELECTION

The rate at which the **MAIN DIAL** causes frequency change is determined, in part, by the number of “steps” per revolution of the dial. The stepping rate may be doubled (or cut in half) via the following procedure:

1. Press and hold in the [**FUNC**] key for $\frac{1}{2}$ second to activate the “Menu” command mode.
2. Rotate the **SELECT** knob until MENU #01 is found.
3. Rotate the **MAIN DIAL** to choose the desired tuning speed. The default value is “200,” and selecting “100” will cut the tuning rate in half.
4. Press the [**FUNC**] key momentarily to save your new setting and exit to normal operation.



*The section just described allows you to change the number of “steps” per revolution of the **MAIN DIAL**. If you want to choose larger or smaller steps, go back to the section before this one, entitled “Frequency Synthesizer Steps.”*

GENERAL COVERAGE 1 MHz FREQUENCY STEPS

1. Press the **SELECT** knob momentarily, then rotate the **SELECT** knob to change frequency in 1 MHz increments.
2. To return to normal steps, again press the **SELECT** knob momentarily.

GENERAL COVERAGE 10 MHz FREQUENCY STEPS

Especially when navigating over the VHF and UHF bands, you may find it more efficient to move in 10 MHz steps, so as to get to the desired frequency more quickly.

1. Press and hold the **SELECT** knob for $\frac{1}{2}$ second, then rotate the **SELECT** knob to change Frequency in 10 MHz increments.
2. To return to normal steps, again press and hold in the **SELECT** knob for $\frac{1}{2}$ second.



To help you remember the procedure for large frequency excursions:

- *press the **SELECT** knob a short time for a “short” step (1 MHz);*
- *press the **SELECT** knob a longer time for a “longer” step (10 MHz).*

Receiver Operation

STACKED VFO SYSTEM

1. Press the [FUNC] key, as needed, until Operating function Row 1 [A/B, A=B, SPL, GMB] appears on the display.
2. Now press the [A](A/B) key (the A/B function) to toggle between the “A” and “B” VFO on the band on which you are currently operating. There are two such VFOs provided on each Amateur band, so you may set **VFO-A** to the CW sub-band, and **VFO-B** to the SSB sub-band, if you like. The operating mode will be preserved, along with the frequency information, on each VFO.

MICROPHONE: PROGRAMMABLE FUNCTION BUTTONS

The **MH-36B6JS** and **MH-42B6JS** microphones include three programmable buttons, labeled **P**, **P1**, and **P2**. These buttons may be used for quick access to frequency control commands of the FT-100. In the default configuration, the **P** button controls **VFO/MR** (Memory Recall); **P1** controls **Band Down**, while **P2** controls **Band Up**.

The configuration of these buttons can be changed via the MENU system:

1. Press and hold in the [FUNC] key for ½ second to enter the MENU mode.
2. Rotate the **SELECT** knob to recall MENU #59 (MIC SW SET).
3. Rotate the **MAIN DIAL** to choose from the following configuration options:
4. When you have made your selection, press the [FUNC] key momentarily to save the new setting and exit to normal operation.

Option	P Button	P1 Button	P2 Button
1	VFO/MR	BAND DOWN	BAND UP
2	VFO/MR	SEARCH	MODE
2	STEP	BAND DOWN	BAND UP
4	STEP	SEARCH	MODE

Receiver Operation

LOCKING FRONT PANEL CONTROLS

The front panel [LOCK] button allows you to disable the **MAIN DIAL** and/or the front panel controls.

In the transceiver's default configuration, pressing the [LOCK] key disables just the **MAIN DIAL**, while the other keys and switches are unaffected. To lock out the remainder of the controls and the **SELECT** knob, use MENU #57 (LOCK KEY):

1. Press and hold in the [FUNC] key for ½ second to enter the MENU mode.

3. Rotate the **MAIN DIAL** to change the setting from "diAL" (lockout of **MAIN DIAL** only) to "PAnEL" (lockout of all controls except the [LOCK] key).
4. When you have made your selection, press the [FUNC] key momentarily to save the new setting and exit to normal operation.

When the controls are locked out, press the [LOCK] key once more to release them to normal operation.



*If MENU #58 (AM&FM CLICK) is set to the "on" position, the **MAIN DIAL** will be disabled during AM and FM operation. In these modes, if you attempt to rotate the **MAIN DIAL**, the "LOCK" icon will appear as a reminder that the **SELECT** knob must be used for frequency selection.*

SETTING THE DISPLAY BRIGHTNESS

The illumination of the display is preset at the factory for satisfactory brightness in most

Receiver Accessories

CLARIFIER (RECEIVER INCREMENTAL TUNING)

The Clarifier (RIT) allows you to set an offset of up to ± 9.99 kHz of the receive frequency relative to your transmit frequency. To achieve wider offsets, you may use the “Split” operating mode, described on page 58.

1. Press the [**CLAR**] key momentarily to activate the Clarifier function. The [**CLAR**] key glows green when the Clarifier is on.
2. Turn the **SELECT** knob, which allows the *receive* frequency to be varied over a range of ± 9.99 kHz.
3. To turn the Clarifier off, press the [**CLAR**] key once more.
4. To reset the Clarifier offset to zero, turn the Clarifier off, then turn the **MAIN DIAL** by any amount. The Clarifier will reset to zero after the first “step” of the **MAIN DIAL**.

CW SPOT

The audio pitch of the CW Sidetone corresponds to the pitch of your CW signal when you are transmitting. Therefore, if you tune the receiver so that the incoming signal’s pitch is the same as that of your radio’s CW Sidetone, your signal will be exactly “zero beat” with that of the other station.



The CW Sidetone pitch may be used for CW spotting only when the CLARIFIER is off (or set to zero). When the CLARIFIER is on, the FT-100’s transmit and receive frequencies will not be the same when the CLARIFIER is set to a non-zero value.

AGC (Automatic Gain Control)

The receiver recovery time constant may be modified to match your operating needs.

1. Press the [**FUNC**] key, as needed, to select Operating Function Row 5 [IPO, ATT, AGC, NB] on the display.
2. Press the [**C**](AGC) key to toggle the AGC recovery time constant among the following selections:

AGC/(FST) → AGC/(SLO) → AGC/(AUT) → AGC/(FST) ...

where “AGC AUTO” represents “FAST” on CW and DIG(AFSK), and “SLOW” on the voice modes. If you select “AGC AUTO”, the “AGC” indicator on the display will become Bold as opposed to its normal appearance.

Receiver Accessories

NOISE BLANKER

The IF Noise Blanker may be useful in reducing or eliminating some types of impulse noise. It may be used alone, or in conjunction with the DSP's Noise Reduction feature.

1. Press the **[FUNC]** key, as needed, to select Operating Function Row 5 [IPD, ATT, AGC, NB] on the display.
2. Press the **[D](NB)** key to activate the Noise Blanker. Note that this feature is not operational in the FM mode, as impulse noise is an amplitude-modulated waveform.
3. To adjust the blanking level, press and hold in the **[D](NB)** key for ½ second. This instantly activates MENU #60, for adjustment of the Noise Blanking level. Rotate the **MAIN DIAL** to set a higher or lower blanking level (on a scale of 1 to 16). Now press the **[FUNC]** key momentarily to save your setting and return to normal operation.
4. Press the **[D](NB)** key again to turn the Noise Blanker off.



As with all IF Noise Blanker circuits, activation of the NB during operating conditions of very strong signals may degrade the overload characteristics of the receiver slightly.

Receiver Accessories

RECEIVER SQUELCH

The **SQL/RF** control's default position (SQUELCH) may be used to mute the receiver background noise when no signal is present.

While no signals are being received, rotate the **SQL/RF** control clockwise until the background noise just disappears. This threshold point is where the best sensitivity to weak signals will be obtained, along with quieting of the background noise.

RF GAIN Control

The alternate use of the **SQL/RF** control is as an **RF GAIN** control, which varies the gain of the receiver's RF and IF stages.

To change the function of the **SQL/RF** control from SQUELCH to RF GAIN, press and hold in the **[FUNC]** key for ½ second (to enter the Menu mode), then rotate the **SELECT** knob to recall MENU #56 (SQL/RF GAIN). Next, rotate the **MAIN DIAL** to select "RF" instead of "SQL" on the Menu. Finally, press the **[FUNC]** key momentarily to save the new setting and exit to normal operation.

Under particularly noisy or crowded conditions, counter-clockwise rotation of the **SQL/RF** control may reduce the background noise level, making reception more pleasant. The S-meter will rise with increasing counter-clockwise rotation of the **SQL/RF** control; this is normal, as it indicates the amount of "AGC" which is being applied so as to reduce the gain of the receiver's RF and IF stages.



This technique may be used in conjunction with the DSP filters, so as to minimize AGC-related "pumping" of the receiver output caused by strong adjacent-frequency signals. In the FM and FM-W modes, the SQL/RF control is fixed in the SQL mode, and cannot be set to the RF function.

IPO (INTERCEPT POINT OPTIMIZATION)

The IPO feature bypasses the receiver RF preamplifier, thereby eliminating the preamp's gain (which may not be needed on the HF bands below about 14 MHz).

1. Press the **[FUNC]** key, as needed, to select Operating Function Row 5 [IPO, ATT, AGC, NB] on the display.
2. Press the **[A](IPO)** key to bypass the receiver input preamplifier.
3. Press the **[A](IPO)** key once more to re-activate the preamp.



This feature is not available on the 144 MHz and 430 MHz bands.

Receiver Accessories

ATT (FRONT END ATTENUATOR)

The Attenuator reduces all signals (and noise) by 12 dB, and it may be used to make reception more pleasant under extremely noisy conditions.

1. Press the [**FUNC**] key, as needed, to select Operating Function Row 5 [IPO, ATT, AGC, NB] on the display.
2. Press the [**B**](ATT) key to activate the Attenuator.
3. Press the [**B**](ATT) key once more to switch the Attenuator out of the receiver front end circuit.



This feature is not available on the 144 MHz and 430 MHz bands.

IF SHIFT

The receiver's **IF SHIFT** feature is an effective interference-reduction tool, which allows you to shift the passband response higher or lower without changing the pitch of the incoming signal.

1. Press and hold in the [**CLAR**] key for ½ second to activate the **IF SHIFT** feature. A graphical display of the **IF SHIFT**'s current position will appear on the LCD.
2. Rotate the select knob, as needed, to reduce or eliminate interference.
3. To switch from **IF SHIFT** to **CLARIFIER** operation, again press the [**CLAR**] key for ½ second. The last setting of the **IF SHIFT** control will be retained until you change it again.



When you turn the IF SHIFT off, the setting of it returns to "zero."

CW PITCH

The CW Pitch adjustment feature controls several aspects of transceiver CW operation simultaneously:

- It controls the pitch of the CW Sidetone;
- It controls the pitch of your transmitted signal (it is the same pitch as the Sidetone);
- It controls the center frequency of the IF passband, used by the IF filters; and
- It controls the center frequency of the DSP CW Peaking Filter.

The CW Pitch is set to a default value of 700 Hz at the factory. To change the CW Pitch:

1. Press and hold in the [**FUNC**] key for ½ second to activate the MENU mode.
2. Rotate the **SELECT** knob to select Menu #50 (CW PITCH).
3. Rotate the **MAIN DIAL** to choose the desired CW Pitch. The available settings are 400/500/600/700/800 Hz.
4. When you have made your selection, press the [**FUNC**] key momentarily to save the new setting and exit to normal operation.



If you set the CW Pitch to a lower value (like 400 Hz), it is slightly easier to “separate” signals in a crowded band, as each synthesizer step is larger (in percentage) at a lower audio frequency.

CW-REVERSE MODE

The default injection mode for CW operation is USB. However, in certain operating situations, you may wish to use the “reverse” sideband, LSB. For example, when operating on 40 meters and lower HF bands, LSB is the mode used for SSB voice communications, and if you wish to change modes to CW, tuning is easier if the same sideband is used. Difficult interference situations may sometimes be solved instantly by using the opposite sideband for reception.

From the CW mode, press and hold in the [**MODE**] key for ½ second to toggle to the “CW-R” (Reverse) mode. You may repeat this process to toggle back to “Normal” (USB-side) operation.

CW (Default)

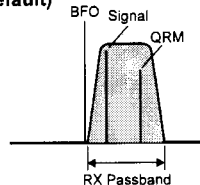

CW-Reverse

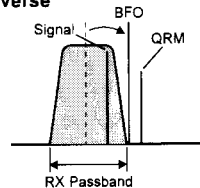

Receiver Accessories

DSP BANDPASS FILTER

The receiver's selectivity may be enhanced via the DSP Bandpass Filter. The bandwidth of the DSP filter may be modified per the procedure below.

1. Press the **[DSP]** key, which selects Operating Function Row 9 [DNR, DNF, DBP] on the display.
2. Press the **[C](DBP)** key to activate the DSP Bandpass Filter.
3. To adjust the High-Cut and Low-Cut characteristics of the DSP Bandpass Filter:
 - ① Press and hold in the **[C](DBP)** key for ½ second. This instantly activates MENU #18 (DSP LPF), which allows adjustment of the High-Cut (Low-Pass) filter.
 - ② Turn the **MAIN DIAL**, as desired, to adjust the high-frequency cutoff of the DSP Bandpass Filter.
 - ③ Now rotate the **SELECT** knob one click clockwise to select MENU #19 (DSP HPF), which allows adjustment of the Low-Cut (High-Pass) filter.
 - ④ Turn the **MAIN DIAL**, as desired, to adjust the low-frequency cutoff of the DSP Bandpass Filter.
 - ⑤ When done, press the **[FUNC]** key momentarily to save the new setting(s) and return to normal operation.
4. Press the **[C](DBP)** key once more to disable the DSP Bandpass Filter.

DSP CW PEAKING FILTER

In the CW mode, pressing the **[C](DBP)** key in Operating Function Row 9 [DNR, DNF, DBP] activates a narrow-bandwidth peaking filter, which may be ideal for use under very crowded conditions. The **DSP CW PEAKING FILTER** also is especially helpful under VHF/UHF weak-signal situations.

The *center frequency* of the **DSP CW PEAKING FILTER** is automatically aligned to be centered on the response you have selected via the CW PITCH command (MENU #50). See page 93 for details.

To change the *bandwidth* of the **DSP CW PEAKING FILTER**:

- ① Press and hold in the **[FUNC]** key for ½ second to enter the MENU mode.
- ② Rotate the **SELECT** knob so as to select MENU #20 (BPF WIDTH).
- ③ Rotate the **MAIN DIAL** to select the desired bandwidth. The available values are 60 Hz, 120 Hz, and 240 Hz (default value: 240 Hz).
- ④ When you have made your selection, press the **[FUNC]** key momentarily to save the new setting and return to normal operation.

Receiver Accessories

DSP NOISE REDUCTION (NR)

The **NOISE REDUCTION** feature of the DSP system may be used to enhance signal-to-noise ratio on weak signals.

1. Press the [**DSP**] key, which selects Operating Function Row 9 [DNR, DNF, DBP] on the display.
2. Press the [**A**](DNR) key to activate the **DSP NOISE REDUCTION** feature.
3. Now press and hold in the [**A**](DNR) key for $\frac{1}{2}$ second. This instantly activates **MENU**

4. Rotate the **MAIN DIAL** to find the point where best signal-to-noise ratio is obtained under the current noise conditions.

5. Press the [**FUNC**] key momentarily to save the new setting and exit to normal operation.
6. To turn off the **DSP NOISE REDUCTION** feature, press the [**A**](DNR) key again.

If noise is present at a level which causes indication on the S meter, the per

Receiver Accessories

AM/FM RECEPTION

In the AM and FM modes, the **MAIN DIAL** is locked out (via a **MENU** setting) so as to allow “channelized” tuning on these modes. To adjust the operating frequency, rotate the **SELECT** knob to change frequency in steps as set via the **[STEP]** key (see page 35).

If you wish to *enable* the **MAIN DIAL** for tuning in the AM and FM modes, change the setting of **MENU #58**:

- ① Press and hold in the **[FUNC]** key for ½ second to enter the **MENU** mode.
- ② Rotate the **SELECT** knob to recall **MENU #58 (AM&FM CLICK)**.
- ③ Rotate the **MAIN DIAL** to set this feature (“**AM&FM CLICK**”) to “Off.”
- ④ Press the **[FUNC]** key momentarily to save the new setting and exit to normal operation.

AUTOMATIC POWER-OFF FEATURE

The FT-100 includes an Automatic Power-Off (APO) feature, which will turn the radio off after a user-defined amount of time. This can prevent your transceiver from draining your car’s battery, for example, if you forget to turn the transceiver off when leaving the car.

To enable and program the APO feature:

- ① Press and hold in the **[FUNC]** key for ½ second to enter the **MENU** mode.
- ② Rotate the **SELECT** knob to recall **MENU #29 (APO TIME)**.
- ③ The default value for the APO feature is “Off.” Rotate the **MAIN DIAL** to select 1 hour, 2 hours, or 3 hours of operation before the radio automatically shuts off.
- ④ Press the **[FUNC]** key momentarily to save the new setting and exit to normal operation.

Once you have programmed a time interval, the APO countdown timer will start whenever some front panel action (tuning, transmission, etc.) ends. If there is no action by you within the time interval programmed, the microprocessor will shut down the radio automatically. Just press and hold in the **[PWR]** switch for ½ second to turn it back on, as usual.

Transmitter Operation



Now that you're familiar with the operation of the receiver, let's turn to trans-

SETTING THE POWER OUTPUT

In the event you wish to set the maximum power output to a particular level (for example, to prevent over-drive of a linear amplifier), the MENU system allows the HF, 50 MHz, 144 MHz, and 430 MHz power levels to be set individually. Moreover, the FT-100 also allows you to set the SSB/CW/FM, and AM power levels individually in each of the above band groupings.

The "0 ~ 100" adjustment scales in each MENU items are shown as a percentage of the maximum allowable power on that band. Therefore, on HF, where the maximum allowable power is 100 watts, a "50%" setting would represent approximately 50 Watts. However, on 144 MHz, where the maximum allowable power is 50 watts, a "50%" setting represents approximately 25 Watts. Minimum power on all bands is approximately 1 Watt.

Transmitter Operation

SSB TRANSMISSION

BASIC SETUP/OPERATION

1. Press the **[MODE]** key so as to recall the SSB(LSB/USB) mode. If you are operating on the 10 MHz or lower bands, the LSB mode will automatically be selected. If you are operating on the 14 MHz or higher bands, the USB mode automatically be selected.
2. Press the **[FUNC]** key, as needed, to recall Operating Function Row 7 **[MTR, TUN, PRO, VOX]**, then press the **[A](MTR)** key to select "ALC" as the meter function (the "MTR" icon becomes faint).
3. Press the microphone's **PTT** switch, and speak into the microphone in a normal voice while watching the meter. The ideal audio input level to the transmitter from the microphone will cause three to four "dots" of indication on the ALC meter. Release the **PTT** switch to return to receive operation.
4. If the ALC level is too high, or too low, you may need to reset the Microphone Gain:
 - ① Press and hold in the **[FUNC]** key for ½ second to enter the MENU mode.
 - ② Rotate the **SELECT** knob to select MENU #25 (MIC GAIN).
 - ③ Close the **PTT** switch, and while speaking into the microphone rotate the **MAIN DIAL** until the proper ALC indication (three to four "dots") is achieved on voice peaks.
 - ④ When done, press the **[FUNC]** key momentarily to save the new setting for the Microphone Gain.



Always make this adjustment while transmitting into a Dummy Load, because reflected power in an antenna system may cause ALC voltage to be generated, throwing off your Mic Gain adjustment.

VOX OPERATION

The VOX system provides automatic transmit/receive switching based on voice input to the microphone. With the VOX system enabled, you do not need to press the **PTT** switch

in order to transmit.

1. Press the **[FUNC]** key, as needed, to select Operating Function Row 7 **[MTR, TUN,**

Transmitter Operation

SSB TRANSMISSION

- ① While still in Operating Function Row 7 [MTR, TUN, PRO, VOX], press and hold in the [D](VOX) key for $\frac{1}{2}$ second. This instantly recalls MENU #54 (VOX GAIN).
- ② While speaking into the microphone, rotate the **MAIN DIAL** to the point where the transmitter is quickly activated by your voice, without causing background noise to activate the transmitter.

③ When you have selected the optimum setting, press the [FUNC] key momentarily to

to save the new setting and return to normal operation.

6. The “Hang Time” of the VOX system (the transmit-receive delay after the cessation of speech) may also be adjusted via the MENU. The default delay is $\frac{1}{2}$ second. To set a different delay time:
 - ① Press and hold in the [FUNC] key for $\frac{1}{2}$ second to activate the MENU mode.
 - ② Rotate the **SELECT** knob to select MENU #55 (VOX DELAY).
 - ③ Rotate the **MAIN DIAL** while saying a brief syllable like “Ah” so as to set the desired delay time.
 - ④ When your adjustment is complete, press the [FUNC] key momentarily to save the new setting and return to normal operation.

Transmitter Operation

CW TRANSMISSION

OPERATION USING STRAIGHT KEY/EXTERNAL KEYING DEVICE

When using a straight key, an external electronic keyer, or a computer-generated keying device, please follow the instructions in this section.

1. Insert your key's (three-conductor) plug into the rear-panel **KEY** jack.
2. Press the [**MODE**] key, as needed, to select the CW mode.
3. Press the [**FUNC**] key, as needed, to recall Operating Function Row 8 [WRI, PLY, BK, KYR].
4. Press the [**C**](BK) key to activate full break-in ("QSK") operation. In this mode, pressing the key will cause instantaneous transmission of your CW carrier signal, and releasing of the key will cause an instantaneous return to receive. The receiver recovery time is fast enough to allow reception between words, as well as dots and dashes within individual letters. When full break-in is active, the "BK" icon will become Bold.
5. For "Semi-Break-In" operation (similar to VOX on SSB/AM), press and hold in the [**C**](BK) key for ½ second. This instantly recalls MENU #51 (CW BREAK-IN). Now rotate the **MAIN DIAL** so as to select "SEMI" instead of "FULL" on the display. Press the [**FUNC**] key momentarily to save the new break-in selection and exit to normal operation.
6. The CW Hang Time (after which the FT-100D returns to the RECEIVE mode after a CW transmission in the "SEMI" mode), can be adjusted using MENU #49 (CW-DELAY).

Transmitter Operation

CW TRANSMISSION

OPERATION USING BUILT-IN ELECTRONIC KEYS

The built-in Electronic Keyer provides a convenient method of generating CW. The Electronic Keyer includes weight and speed adjustment, a programmable envelope delay, and a message memory for sending of repetitive messages (like “CQ DX CQ DX DE W6DXC W6DXC $\overline{\text{AR}}$ ”).

1. Connect your keyer paddle's cable to the **KEY** jack on the rear panel of the transceiver.
2. Press the **[MODE]** key, as needed, to select the CW mode.
3. Press the **[FUNC]** key, as needed, to select Operating Function Row 8 **[WRI, PLY, BK, KYR]** on the display.
4. Press the **[D](KYR)** key to activate the Electronic Keyer (the “KYR” icon will become Bold).
5. The Keyer Speed may be adjusted using MENU #53. To do this:
 - ① Press and hold in the **[FUNC]** key for ½ second to enter the MENU mode.
 - ② Rotate the **SELECT** knob to select MENU #52 (KEYER SPEED).
 - ③ Rotate the **MAIN DIAL**, while sending, to set the desired sending speed.
 - ④ When done, press the **[FUNC]** key momentarily to save the new setting and exit to normal operation.
6. The “Break-in” mode, Hang Time, and Sidetone Pitch may all be adjusted as described previously.
7. The Dot:Space and Dash:Space ratios may be adjusted (individually) via MENU items #47 and #48, respectively. See page 92 for details. As the default settings are the international standards of 1:1 and 3:1, we generally do not recommend changes be made to these settings.
8. A programmable delay in the keyer's transmission string may be added. This may be helpful when using a linear amplifier, as it can allow the amplifier's relays a few extra milliseconds in order to become properly seated. This delay shifts the entire stream of dots and dashes, without changing the weight or truncating the character(s). To do this, use MENU #53 (GSK DELAY) (see page 93).
9. You may also enable or disable the Automatic Character Space (ACS) feature of the keyer. The default setting for this feature is “enabled.” To change this setting:
 - ① From Operating Function Row 8, press and hold in the **[D](KYR)** key for ½ second. This instantly recalls MENU #46 (KEYER TYPE).
 - ② Rotate the **MAIN DIAL** to change the selection from the following list:

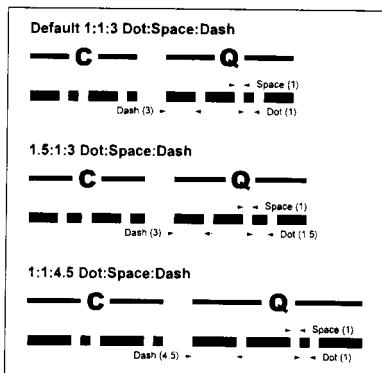

Transmitter Operation

CW TRANSMISSION

EL1 Iambic keyer with ACS disabled.

EL2 Iambic keyer with ACS enabled.

BUG Mechanical “Bug” key emulation. The “dot” paddle produces dots automatically, while the “dash” paddle produces dashes *manually*.

- ③ When you have made your selection, press the **[FUNC]** key momentarily to save the new setting and exit to normal operation.



To store a repetitive message using the Message Memory function (see below), MENU #46 must be set to EL2. You can return to EL1 after message storage, however, if you like.

OPERATION USING MESSAGE MEMORY KEYS

The FT-100 includes an easy-to-use CW Message Memory system, allowing you to store and play back a message of up to 50 characters in length.

Message Memory Storage

1. If you have not done so already, select Operating Function Row 8 [**WRI**, **PLY**, **BK**, **KYR**].
2. Activate the Electronic Keyer (press **[D]**(**KYR**) in the “EL2” mode, as described previously.
3. Press and hold the **[A]**(**WRI**) key for ½ second, then start sending the message to be stored (e.g. “CQ CQ TEST W7DXC W7DXC K”). When you are done, the storage process will terminate automatically (5 seconds after the last character is sent).

Review of Stored Message (Playback without On-The-Air Transmission)

1. Disable transmission temporarily by pressing the **[C]**(**BK**) key so as to cause the “BK” icon will revert to its normal (non-Bold) state.
2. Press the **[B]**(**PLY**) key to play back the message. You will hear the message in the Sidetone, and you may check it for accuracy during playback.

Transmission of Stored Message (On-The-Air Playback)

1. Re-activate transmission capability by pressing the **[C]**(**BK**) key. The “BK” icon will become Bold.
2. Press the **[B]**(**PLY**) key to transmit the stored message. The transmitter will automatically be activated, and the progress of the message can be monitored via the Sidetone. When the message is complete, the FT-100 will automatically return to the RECEIVE mode.

Transmitter Operation

FM OPERATION

SIMPLEX (NON-REPEATER) OPERATION

1. Press (or press and hold for ½ second) the [**MODE**] key to recall the FM mode (not FM-Wide).
2. Rotate the **SELECT** knob, or press the [**UP**] or [**DOWN**] keys on the microphone, to select the desired operating frequency.
3. Close the microphone's **PTT** switch to activate the transmitter. Speak into the microphone in a normal voice level.
4. Release the **PTT** switch to return to the receive mode.
5. If you get reports that your voice level is too high or too low, you may need to adjust the FM-mode Microphone Gain. The procedure is similar to that used on SSB:
 - ① Press and hold in the [**FUNC**] key for ½ second to enter the MENU mode.
 - ② Rotate the **SELECT** knob to select MENU #26 (FM MIC GAIN).
 - ③ Rotate the **MAIN DIAL** to increase or decrease the Mic Gain setting.
 - ④ When done, press the [**FUNC**] key momentarily to save the new setting for the FM Mic Gain.
6. The VOX feature is operational during FM transmission. From Operating Function Row 7 [MTR, TUN, PRO, VOX], press the [**D**](VOX) key to activate/deactivate VOX.



The FM deviation can be adjust via the Menu Item 33 (FM DEV).

SWR METER

Once you have made the needed setup adjustments to your FT-100D, you may find it more useful to set the display's meter for monitoring of SWR, instead of ALC. This will alert you to sudden changes in your antenna system, so that you can take corrective action promptly.

To activate the SWR meter:

1. Press the [**FUNC**] key, as needed, to recall Operating Function Row 7 [MTR, TUN, PRO, VOX], then press [**A**](MTR) to recall the metering function.
2. If the meter currently shows "ALC" as the metering mode, press the [**A**](MTR) key momentarily to activate the SWR meter. The "MTR" symbol will become Bold, and the thin line below the "PO" bar graph will display relative SWR.

Transmitter Operation

FM OPERATION

REPEATER OPERATION

1. Press the **[FUNC]** key, as needed, to select Operating Function Row 2 [**V>M**, **M>V**, **RPT**, **REV**].
2. Press the **[C](RPT)** key to activate repeater operation. Pressing the **[C](RPT)** key causes two important functions to become activated:
 - The transmitter frequency will be shifted by a default value so as to access the repeater input frequency;
 - A repeater access tone will be superimposed on your signal, as many repeaters on these bands use CTCSS to prevent false activation of the repeater by random noise.
3. If the default repeater shifts and/or access tone are not appropriate for your area, they may be set independently for each band. The MENU selections which pertain to these functions are shown below.
 - To set the CTCSS Tone, use MENU #12 (TONE FREQ).
 - To set the 29 MHz repeater shift, use MENU #40 (HF RPT SHIFT). See page 91.
 - To set the 50 MHz repeater shift, use MENU #41 (50 RPT SHIFT). See page 91.
 - To set the 144 MHz repeater shift, use MENU #42 (144 RPT SHIFT). See page 91.
 - To set the 430 MHz repeater shift, use MENU #43 (430 RPT SHIFT). See page 91.
4. One press of the **[C](RPT)** key will have set the FT-100 for “Minus Shift” operation. In this situation, you will observe the “RP-” indicator on the display. If your repeater uses a positive shift (instead of negative), press the **[C](RPT)** key again: the “RP+” indicator will replace the “RP-” indicator on the display.
5. Set the FT-100’s receiver to the repeater output (downlink) frequency.
6. Close the **PTT** switch and speak into the microphone. You will observe that the transmitted frequency has shifted according to the setting of the **[C](RPT)** key.
7. Release the **PTT** switch to return to the RECEIVE mode.
8. With repeater shift activated, you can temporarily reverse the transmit and receive frequencies by pressing the **[D](REV)** key. The “RP-” icon will blink while “Reverse” shift is activated. Press the **[D](REV)** key again to revert to the “Normal” shift direction.
9. On many transceiver versions, the Automatic Repeater Shift (ARS) feature is enabled at the factory. This feature automatically activates the appropriate repeater shift when you are operating inside the designated 144 MHz or 430 MHz FM repeater sub-bands in your country. If you wish to change the settings for the ARS, use MENU #44 (144 ARS) or MENU #45 (430 ARS) (see page 92).

Transmitter Operation

FM OPERATION

CTCSS ENCODE AND TONE SQUELCH OPERATION

Many repeaters require a CTCSS Encode or 1750 Hz Burst Tone in order for the repeater to be activated. The CTCSS Tone Squelch feature (CTCSS "Decoder"), moreover, allows you to monitor silently for calls on busy channels, with your receiver's Squelch only opening up when a signal bearing the matching CTCSS tone appears on your frequency. The Tone Squelch feature requires the installation of the optional **FTS-27** module (see page 107)

1. Set the CTCSS Tone frequency via MENU #12 (TONE FREQ).
2. Press the **[FUNC]** key, as needed, to recall Operating Function Row 3 [TON, DCS, ART], then press the **[A](TON)** key once to activate the Tone Encoder (the "ENC" icon will appear on the display). When you transmit, the Subaudible tone selected via MENU #12 will be superimposed on your signal.

Transmitter Operation

FM OPERATION

DCS OPERATION

Another form of tone access control is Digital Code Squelch, or DCS. It is a newer, more advanced tone system that is less susceptible to false triggering than CTCSS. A DCS Encoder/Decoder is built into your FT-100, and operation is very similar to that just described for CTCSS.

1. Set the desired DCS code via MENU #07 (DCS CODE).
2. Press the [FUNC] key, as needed, to recall Operating Function Row 3 [TON, DCS, ART], then press the [B](DCS) key to activate the DCS Encoder/Decoder (the "DCS" icon will appear on the display). The receiver will remain muted until a matching DCS code is received on an incoming signal.
3. Press the [B](DCS) key once to cancel the DCS (the "DCS" icon icons will disappear).



You can recall the MENU #07 (DCS CODE) instantly by pressing and holding in the [B](DCS) key for 1/2 second.

DCS CODE													
023	025	026	031	032	036	043	047	051	053	054	065	071	
072	073	074	114	115	116	122	125	131	132	134	143	145	
152	155	156	162	165	172	174	205	212	223	225	226	243	
244	245	246	251	252	255	261	263	265	266	271	274	306	
311	315	325	331	332	343	346	351	356	364	365	371	411	
412	413	423	431	432	445	446	452	454	455	462	464	465	
466	503	506	516	523	526	532	546	565	606	612	624	627	
631	632	654	662	664	703	712	723	731	732	734	743	754	

Transmitter Operation

FM OPERATION

DTMF OPERATION

When using the optional **MH-36B6JS** DTMF microphone, you can manually send out DTMF tones for autopatch or repeater control purposes.

In the FM mode, close the microphone's **PTT** switch, as usual. While holding in the **PTT** switch, press the keys corresponding to the tones you wish to send. When you are finished, after releasing the final DTMF key, you may release the **PTT** switch.

ARTS™ (AUTO RANGE TRANSPOND SYSTEM) OPERATION

The ARTS™ system uses DCS signaling to inform you when you and another ARTS-equipped station are within communications range.

1. Press the [**FUNC**] key, as needed, to recall Operating Function Row 3 [TON, DCS, ART].
2. Press the [**C**](ART) key to activate the ARTS feature (the “ART” icon will appear on the display).
Your display will change to “out rng” to indicate the beginning of ARTS operation. Every 15 seconds, your radio will transmit a “polling” call to the other station. When that station responds with its ARTS polling signal, your display will change to “in rng” to confirm his response.
3. To cancel ARTS operation, press the [**C**](ART) key again (the “ART” icon will disappear from the LCD).



The ARTS feature offers a choice of beep options to alert you to the current status of ARTS operation. Check out MENU #09 (ARTS BEEP) on page 85.

CW IDENTIFIER SETUP

The ARTS feature includes a CW identifier. The radio can be instructed to send “DE (your call/sign) K” in Morse code every ten minutes during ARTS operation.

To program the CW IDer, use MENU #11 (ID), as described on page 86. And to activate the CW IDer, use MENU #10 (CW ID).

Transmitter Operation

SPLIT FREQUENCY OPERATION

The FT-100 provides convenient split-frequency operation, using the VFO-A and VFO-B, for DX working and other operating situations requiring unique split frequency pairs.

The example below will describe a split-frequency DX situation on the 20-meter band, with a DX station transmitting on 14.025 MHz, listening 10 kHz higher in the band.

1. With the VFO-A set to 14.025.00 MHz CW.
2. Press the **[FUNC]** key, as needed, to select Operating Function Row 1 [**A/B**, **A=B**, **SPL**, **QMB**] on the display.
3. Press the **[A](A/B)** key momentarily to to VFO-B.
4. Tune the VFO-B frequency to 14.035.00 MHz.
5. Press the **[C](SPL)** key momentarily. The FT-100 will now transmit using the VFO-B frequency, and will receive using the VFO-A frequency. The “SPL” icon will appear on the display.
6. To listen to the pile-up calling the DX station (so as to align your frequency more closely to that of the station being worked by the DX), press the **[A](A/B)** key. The VFO-B will now be tuning in the vicinity of 14.035 MHz, and you can zero in on the DX station’s listening frequency by tuning in on the station in QSO with the DX. Press **[A](A/B)** again to return the receiver to the DX station’s transmitting frequency.
7. Press the **[C](SPL)** key once more to cancel split operation, and the “SPL” icon will disappear from the display.

TIME-OUT TIMER

Most often used on FM, the transmitter’s Time-Out Timer (TOT) feature disables the transmitter after a user-defined period of transmission. This feature may be useful in preventing a “stuck microphone” (accidental closure of the **PTT** switch) from causing interference to other users.

To activate the Time-Out Timer:

- ① Press and hold in the **[FUNC]** key for ½ second to enter the **MENU** mode.
- ② Rotate the **SELECT** knob to recall **MENU #30 (TOT TIME)**.
- ③ The default value for this feature is “20 minutes.” Rotate the **MAIN DIAL** to set a new value from 1 minute to 20 minutes.
- ④ When you have made your selection, press the **[FUNC]** key momentarily to save the new setting and exit to normal operation.

Transmitter Operation

DIGITAL MODE OPERATION

The FT-100 provides extensive capability for digital mode operation on the HF, VHF, and UHF bands. The use of AFSK (Audio Frequency-Shifted Keying) configurations allows a wide variety of different communication modes to be utilized. The MENU provides for specific digital mode selections, which include custom BFO offsets to optimize the receive and transmit passbands for the mode selected.

RTTY (RADIO TELETYPE) OPERATION

1. Connect your TNC (Terminal Node Controller) or terminal modem to the rear panel's **DATA** jack, per the instructions on page 20. Be certain to use the "TX AUDIO" line from your TNC, not an "FSK Key" line, for the transmit-data connection.
2. Press the [**MODE**] key, as needed, to select the DIG mode (the "DIG" icon will appear on the display). If "AM" appears in the mode selections, instead of "DIG," press and hold in the [**MODE**] key for ½ second when you are in the AM mode; this will cause the transceiver to toggle from AM to DIG.
3. Press and hold in the [**FUNC**] key for ½ second to activate the MENU mode.
4. Rotate the **SELECT** knob to select MENU #34 (AFSK MODE).
5. Rotate the **MAIN DIAL** to set the AFSK mode to "rtty-L" (AFSK operation using the LSB mode) or "rtty-U" (AFSK operation using USB).
Note: Most Amateur RTTY operation utilizes the LSB mode.
6. Check the settings of the MENU items associated with RTTY operation:
MENU #35 (RTTY SHIFT): 170/425/850 Hz (Default: 170 Hz)
MENU #36 (RTTY DISPLAY): nor/CAR (Default: nor)
7. If the Meter is not set to monitor ALC voltage, press the [**FUNC**] key, as needed, to

select Operating Function Row 7 [MTR, TUN, PRO, VOX], then press the [**A**](MET) key so as to select metering of ALC.

8. Press and hold in the [**FUNC**] key for ½ second to enter the MENU mode, then rotate the **SELECT** knob to select MENU #28 (AFSK LEVEL).
9. Following the instructions for your TNC's software, activate the transmitter from the computer keyboard; this should cause the AFSK output from the TNC to be sent to the radio. While transmitting, view the ALC meter; four "dots" of ALC indication should be observed. If not, rotate the **MAIN DIAL** to adjust the AFSK level within the FT-100 for two to three dots of indication on the ALC meter. Press the [**FUNC**] key momentarily to save the new AFSK level setting and return to normal operation. You are now ready for RTTY operation.



The FT-100 is designed for a 50% duty cycle, so you may wish to set MENU #21 for 50 Watts of power output if you plan on making lengthy RTTY transmissions.

Transmitter Operation

DIGITAL MODE OPERATION

PACKET (300 BPS HF OR 1200/9600 BPS FM) OPERATION

1. Connect your TNC to the rear panel's **DATA** jack, per the instructions on page 21.
2. Press the [**MODE**] key, as needed, to select the DIG mode. The "DIG" icon will appear on the display.
3. Press and hold in the [**FUNC**] key for ½ second to activate the MENU mode, then rotate the **SELECT** knob to recall MENU #34 (AFSK MODE).
4. Rotate the **MAIN DIAL** to select the desired Packet mode:
 - Pkt-L: 300 bps HF packet using LSB mode
 - Pkt-U: 300 bps HF packet using USB mode
 - Pkt-F: 1200/9600 bps FM packet



If you have chosen Pkt-L or Pkt-U, skip the next step, and proceed instead to Step 6.

5. If you have selected "Pkt-F" as the Packet mode, rotate the **SELECT** knob to recall MENU #37 (PACKET RATE). Now rotate the **MAIN DIAL** to choose either 1200 bps or 9600 bps Packet operation.
6. If you have chosen Pkt-L or Pkt-U:
 - Check the settings of MENU #38 (PKT DISPLAY) and MENU #39 (PACKET TONE), to be sure that they are appropriate for your operating needs and the setup of your TNC.
 - Rotate the **SELECT** knob to select MENU #28 (AFSK LEVEL). Now activate the transmitter using your TNC's software, and rotate the **MAIN DIAL** to set the AFSK input level so that the ALC meter shows four "dots" of deflection (as previously described for RTTY).
7. Press the [**FUNC**] key momentarily when all settings are completed to save the new settings and exit to normal operation.

OPERATION ON ALASKA EMERGENCY FREQUENCY: 5167.5 KHz

Section 97.401(d) of the regulations governing amateur radio in the United States permit emergency amateur communications on the spot frequency of 5167.5 kHz by stations in (or within 92.6 km of) the state of Alaska. This frequency is *only* to be used when the *immediate safety of human life and/or property* are threatened, and is *never* to be used for routine communications.

The FT-100 includes the capability for transmission and reception on 5167.5 kHz under such emergency conditions via the Menu system. To activate this feature:

- ① Press and hold in the [**FUNC**] button for ½ second to activate the MENU mode of operation.
- ② Rotate the **SELECT** knob to select MENU #66 (5167.5 kHz).
- ③ Rotate the **MAIN DIAL** to select “On” for this feature.
- ④ Press the [**FUNC**] key momentarily exit the MENU mode.

Emergency communication on this spot frequency is now possible:

Rotate the **SELECT** in the MR mode, as necessary, to locate the *Emergency Channel*, which will be located between the *Memory channel 300* and *DUP 001*.

Note that the receive-mode CLARIFIER functions normally while using this frequency, but variation of the transmit frequency is not possible. Activation of MENU #66 does not enable any other out-of-amateur-band capability on the transceiver. The full specifications of the FT-100 are not necessarily guaranteed on this frequency, but power output and receiver sensitivity should be fully satisfactory for the purpose of emergency communication.

To return to normal transceiver operation, just press the [**VFO/MR**] key, which will cause you to switch to one of the VFOs. To disable operation on the Alaska Emergency Frequency, repeat the procedure detailed above, but set MENU #66 to “Off” in step ③ of the procedure.

In an emergency, note that a half-wave dipole cut for this frequency should be approximately 45’3” on each leg (90’6” total length).

Emergency operation on 5167.5 kHz is shared with the Alaska-Fixed Service. This transceiver is *not* authorized for operation, under the FCC’s Part 87, for aeronautical communications.

Active-Tuning Antenna System (ATAS-100) Operation

The optional ATAS-100 Active-Tuning Antenna System provides operation on a number of HF bands (7/14/21/28 MHz) plus 50 MHz, 144 MHz, and 430 MHz. The FT-100 provides microprocessor control of the tuning mechanism in the ATAS-100 for convenient automatic tuning.

Before operation can begin, you must instruct the FT-100's microprocessor that the ATAS-100 is being used. This is done using the MENU:

- ① Press and hold in the **[FUNC]** key for ½ second to activate the MENU mode.
- ② Rotate the **SELECT** knob to recall MENU #61 (TUNER/ATAS).
- ③ The default setting for this MENU item is "Off." Rotate the **MAIN DIAL** to change

the setting to "AtAS-1" if you are using the ATAS-100 for all bands (you must connect an external diplexer to combine the two antenna ports so as to use the ATAS-100 on all bands). Or make the setting "AtAS-2" if you are just using the ATAS-100 on 7~50 MHz, with a dual-band VHF/UHF antenna connected *separately* to the 144/430 MHz antenna port.

- ④ Press the **[FUNC]** key momentarily to save the new setting and exit to normal operation.

AUTOMATIC TUNING

1. Press the **[FUNC]** key, as needed, to recall Operating Function Row 7 [MTR, TUN, PRO, VOX].
2. Press the **[B](TUN)** key to turn the ATAS-100 on (this action only supplies voltage to the antenna at this point; re-tuning does not begin). The "TUN" icon will become Bold.
3. Now press and hold in the **[B](TUN)** key for ½ second to initiate ATAS-100 tuning. The transmitter will automatically be activated, a carrier will be sent, and the antenna's length will be adjusted for best SWR.
4. If the microprocessor determines that the antenna's length is radically incorrect from the optimum value, no carrier will be sent out. Instead, in the receive mode, the antenna will retract to its shortest position (this may take up to one minute). While this is happening, do *not* press the **[B](TUN)** key again. When the ATAS-100 reaches its minimum length, automatic tuning will be initiated, and the transmitter will automatically shut off when a satisfactory SWR is achieved.



On the 144 MHz and 430 MHz bands, the ATAS-100 does not require a tuning process. SWR will be satisfactory when the antenna is fully retracted.

5. When you wish to conclude ATAS-100 operation, press the **[B](TUN)** key so that the "TUN" icon will revert to its normal (non-Bold) state.

Active-Tuning Antenna System (ATAS-100) Operation

MANUAL TUNING

In some instances, the SWR may be slightly improved by manual adjustment of the antenna position. This may be needed for operation on bands like 17 meters, where the “Q” of the ATAS-100 is high, causing a narrow resonance range.

Before Manual Tuning, press the **[FUNC]** key, as needed, to recall Operating Function Row 7 [MTR, TUN, PRO, VOX], then press the **[A](MTR)** key to change the ALC meter to the SWR meter (“MTR” icon will become Bold).

To tune the ATAS-100 manually, press and hold in the microphone **PTT** switch. With the transceiver in the “Transmit” mode, press and hold in the **[UP]** key (to raise the antenna) or the **[DWN]** key (to lower the antenna). While you hold in one of these keys, the FT-100 will generate a carrier, and you may watch the top scale of the FT-100’s meter, looking for the meter indication to reach its minimum value. When this is reached, release the **[UP]** or **[DWN]** key, then release the **PTT** key to return to the “Receive” mode.



- *Once automatic matching has been successfully accomplished, you must change frequency by at least 10 kHz before attempting automatic matching again. Within a window of ± 10 kHz from a match point, the transceiver’s microprocessor will ignore any command to attempt automatic matching.*
- *Antenna tuning is accomplished using a “CW” carrier, although the mode indication will not change to “CW” (if you are operating on another mode) during antenna tuning.*
- *If you see a “HI SWR” Icon on the LCD, it may mean that there is a problem in your coaxial cable (bad connection, etc.) which is preventing successful tuning. Replace the cable, or try adding a few feet/meters of cable (to eliminate the possibility of adverse “transformer action” in the 50 Ω cable during the tuning process).*
- *If you are able to achieve an SWR of less than 2:1 via manual tuning, the FT-100 will “accept” the manual setting, and you may then re-tune automatically when changing bands.*
- *If, however, you stop manual tuning at a non-optimum setting (SWR >2:1), the FT-100 will not permit further automatic tuning. To refresh the setting of the ATAS-100, press the **[DWN]** key until the ATAS-100 will fully retract. You may then restart automatic tuning per the procedures described earlier.*
- *Although the ATAS-100 is not specified for use on the 10, 18, and 24 MHz bands, it usually is possible to achieve a satisfactory SWR on these bands. Please feel free to experiment on these bands, if you like.*



Active-Tuning Antenna System (ATAS-100) Operation

ATAS-100 OPERATING TIPS

The information below will help you derive the best performance possible from the ATAS-100 Active-Tuning Antenna System.

GROUNDING

It is critically important that you establish a good mechanical and RF ground connection for your ATAS-100 (as with all vertical antennas). Mobile mounts which are bolted through the vehicle's roof, or otherwise mechanically affixed, will usually be satisfactory. However, magnetic mounts do not provide the RF grounding necessary for good performance, and are not recommended for use with this antenna.

TUNING PROCEDURE

The feedpoint impedance of the ATAS-100 (resistance and reactance) will necessarily vary over a wide range when you change bands. Occasionally, the transceiver's microprocessor will not *initially* be able to determine the proper direction for the ATAS-100 to travel (inward or outward) for best SWR.

To resolve this situation, the transceiver will then command the ATAS-100 to retract fully to its minimum height, and thence restart the tuning process. In this instance, the "TUN" icon will remain on the display after you press the [B](TUN) key. If this happens, do not press the [B](TUN) key repeatedly. The transceiver will remain in the *receive* mode as it retracts (this may take up to one minute). Thereafter, the transmitter will be engaged, and the ATAS-100 will be automatically adjusted for best SWR. The "TUN" icon will then disappear from the LCD, and you will be ready for operation.

The command which retracts the ATAS-100 to its minimum height utilizes a fixed timer. If the ATAS-100 reaches its minimum height before the timer has expired, you may observe the antenna's motor continuing to rotate; this is normal, as the ATAS-100's retraction mechanism includes a clutch assembly to prevent damage to the antenna or motor.

EXTERNAL WATTMETERS

If you wish to use an external wattmeter in conjunction with the transceiver and your ATAS-100, please check the wattmeter with an Ohmmeter prior to installation. Be sure there is a direct connection between the "IN" and "OUT" jacks of the wattmeter (zero resistance), and also ensure that there is a completely *open* circuit between the center pin and shield of the wattmeter's output jack. Some wattmeters use a coil or other device which shorts the center pin to ground at DC, and this type of internal wattmeter circuitry will not allow the tuning function of the ATAS-100 to operate.

Active-Tuning Antenna System (ATAS-100) Operation

ATAS-100 OPERATING TIPS

OPERATION ON 30/17/12 METERS

Although the ATAS-100 is not specified for operation on the above bands, and optimum operation is therefore not guaranteed, the ATAS-100 generally can be tuned successfully on these bands (some manual adjustment may be required). Operation of the ATAS-100 on these bands will not damage the antenna's components; please feel free to experiment on these bands, if you like.

FC-20 Automatic Antenna Tuner Operation

The optional FC-20 Automatic Antenna Tuner provides automatic tuning of a coaxial line so as to present a nominal 50Ω impedance to the FT-100's HF/50 MHz antenna port.

Before operation can begin, you must instruct the FT-100's microprocessor that the FC-20 is being used. This is done using the MENU:

- ① Press and hold in the **[FUNC]** key for ½ second to activate the MENU mode.
- ② Rotate the **SELECT** knob to recall MENU #61 (TUNER/ATAS).
- ③ The default setting for this MENU item is "off." Rotate the **MAIN DIAL** to change the setting to "tunEr."
- ④ Press the **[FUNC]** key momentarily to save the new setting and exit to normal operation.
- ⑤ Turn the FT-100's power Off, then On again, to re-initialize the FT-100's microprocessor regarding the tuner status (no other setting will be affected).

Operation is similar to the procedure for the ATAS-100:

1. Press the **[FUNC]** key, as needed, to recall Operating Function Row 7 [MTR, TUN, PRO, VOX].
2. Press the **[B](TUN)** key for ½ second to turn the FC-20 on. The "TUN" icon will appear on the display.
3. Press and hold in the **[B](TUN)** key to initiate automatic tuning. The FT-100 transmitter will be activated, a carrier signal will be sent out, and the coils and capacitors in the FC-20 will be selected/adjusted for optimum SWR. When tuning is complete, the transmission will cease, and you will be ready for operation on this frequency.



Tuning data will be stored in the FC-20's Memory system. See the discussion below for details on how this works.

FC-20 Automatic Antenna Tuner Operation

ANTENNA TUNER MEMORY SYSTEM

The FC-20, working in concert with the FT-100, can store impedance matching data in its micro-computer memory, so as to provide instant adjustment as you transmit in different areas of a particular band. A total of 100 memories are provided: 11 of these are “general” memories apportioned one per band, while the remaining 89 are allocated for specific frequency data within the various bands, with the capability to resolve new tuning data every 10 kHz. A few guidelines should be noted regarding the FC-20’s memory system:

1. Tuning data is stored when you make an active effort to store it by pressing and holding in the [B](TUN) key for ½ second. Although the tuner will automatically activate itself if it encounters more than 1.5:1 SWR, this memory will *not* be stored unless you have pressed the [B](TUN) key for ½ second. This allows you to store your favorite operating frequency areas into tuner memory without tying up memory space with matching data on seldom-used frequencies.
2. If the FC-20 cannot resolve a satisfactory match because the SWR is above 3:1 (2:1 on the 50 MHz band), the tuning process will stop, and no memory data will be stored. However, you may wish to move frequency a few kHz, then press the [B](TUN) key again for ½ second, as slight changes in the reactance may allow a match to be obtained. Then go back to the original frequency and try again.
3. Another technique which may allow matching in some situations is to add a few feet or meters of coaxial cable on the “antenna side” of the FC-20. This will change the impedance transformation taking place in the coaxial cable, possibly moving the impedance presented to the FC-20 into an acceptable range. Note that this is not changing the actual antenna SWR, but only the impedance “seen” by the FC-20’s matching circuits.
4. If your antenna system presents an SWR of less than 1.5:1, you may wish to turn off the antenna tuner, as full transmitter power will be delivered to the antenna system without intervention by the FC-20.
5. If the impedance encountered by the FC-20 exceeds 3:1, and the “HI SWR” icon is illuminated, the microprocessor will *not* retain the tuning data for that frequency, as the FC-20 presumes that you will want to adjust or repair your antenna system so as to correct the high SWR condition.



Memory System Operation

The FT-100 provides a wide variety of memory system resources. These include:

- 300 “standard” memory channels, numbered “001” through “300.” These memories are partitioned into six Memory Groups, each holding up to 50 memory channels.
- Five QMB (Quick Memory Bank) channels, providing one-touch storage and recall of prime operating frequencies. The QMB channels are labeled “QMB 001” through “QMB 005.”
- 20 Split Frequency memory channels, used for storing frequency settings when the transmitter and receiver frequency are different. The Split channels are labeled “DUP 001” through “DUP 020.”
- Four “HOME” channels, for storage and quick recall of one prime frequency on each of the four band groupings: **HF, 50 MHz, 144 MHz, and 430 MHz**. These channels are labeled “HOM 001” through “HOM 004.”
- 20 memory channels for the band-edge memories also known as “Programmable Memory Scan” channels, labeled “PGM 001” through “PGM 020.”

These memories do not just store away the operating frequency; thanks to the enhanced memory space provided in the FT-100, the following data will be stored into each memory channel:

- Operating frequency
- Operating mode (LSB, USB, CW, etc.)
- Receiving filter bandwidth
- Memory Channel “Skip” status
- IPO status
- ATT status
- Repeater Shift information

Memory System Operation

QMB CHANNEL PROGRAMMING/RECALL

QMB CHANNEL STORAGE

1. Tune in the desired frequency and set the operating mode and bandwidth.
2. Press and hold in the [MEM] key for 1/2 second until the [MEM] key lights up.

double beep provides audible confirmation that the memory storage into QMB channel "QMB 001" was successful.

3. As you store other frequencies into QMB memories, the latest data is stored into memory register "QMB 001", and the data previously stored into channel "QMB 001" is shifted to channel "QMB 002", the data previously stored into "QMB 002" is stored into "QMB 003", and so forth. When all five QMB memories are full, and you store a new frequency, the data stored in channel "QMB 005" will be purged. Frequency data will be stored and purged on a first-in, first-out basis.

QMB CHANNEL RECALL

1. Press the [FUNC] key, as needed, to recall Operating Function Row 1 [A/B, A=B, SPL, QMB] then press the [D](QNB) key momentarily to recall the currently-active QMB channel.
2. Press the [D](QNB) key repeatedly to cycle though the QMB channels, in the same sequence as shown for QMB Channel Storage.

Memory System Operation

MEMORY OPERATION ON "REGULAR" MEMORY CHANNELS (CHANNEL #001 TO #300)

MEMORY CHANNEL STORAGE

1. Tune in the desired frequency, and set the operating mode and bandwidth.
2. Press the **[FUNC]** key, as needed, to recall the Operating Function Row 2 [**V>M**, **M>V**, **RPT**, **REV**].
3. Press the **[A](V>M)** key momentarily to enter the "Memory Check" mode, which is used to find an unused memory channel. The frequency stored (if any) on the current memory channel will be shown in the display.
4. Rotate the **SELECT** knob to select the channel on which you wish to store the current frequency data.



Remember that the memories are partitioned into Memory Groups of 50 channels each. Select a memory channel within the right Group (e.g. Channel 1~50, 51~100, 101-150, etc.) if you intend to utilize the partitioning.

5. Press and hold in the **[A](V>M)** key for $\frac{1}{2}$ second until you hear a double beep, which confirms that the frequency information was successfully stored.

Memory System Operation

MEMORY OPERATION ON “REGULAR” MEMORY CHANNELS (CHANNEL #001 TO #300)

MEMORY CHANNEL RECALL

1. If you currently are in the VFO tuning mode, press the [VFO/MR] key once to enter the “Memory” mode (the “MEM” icon will appear on the display).
2. To select another memory channel, turn the **SELECT** knob.
3. To restrict your memory channel selection just to one Memory Group (50 channels), press and hold the **SELECT** knob for ½ second. Now, the “GCH” icon will appear on the display, and only those channels within the current Memory Group will be available for recall via step 2. above.
4. To change Memory Groups, press and hold the **SELECT** knob for ½ second again (the “GCH” icon will disappear), then turn the **SELECT** knob to step through the channels until you enter another group (a Group Number will *not* appear at this time). You may now press and hold the **SELECT** knob for ½ second to restrict memory channel access to the newly- selected Group.
5. Once you are operating on a memory channel, you may tune off of the originally-memorized frequency (as though you were in the VFO mode). Just rotate the **MAIN DIAL** knob or pressing the **SELECT** knob momentarily; the “MEM” icon will be replaced by one which indicates “MT,” indicating that you have now shifted into the “Memory Tuning” mode. When operating the Memory Tuning mode, if you find another frequency you wish to store into another memory channel, just press the [A](V>M) key momentarily, select a new memory channel via the **SELECT** knob, then press and hold the [A](V>M) key for ½ second (until you hear the double beep). To exit the Memory Tuning mode, press the [VFO/MR] key as follows:
 - One touch of the [VFO/MR] key returns you to the original memory frequency.
 - A second touch of the [VFO/MR] key will cause you to exit the Memory mode and return to the VFO mode (the “MEM” indicator will be replaced by “V-A” or “V-B”).



*To simplify the memory recall process, press the [STEP] key first, then rotate the **SELECT** knob to recall only channels on which data is stored (vacant memory channels will be skipped).*

To revert to normal operation, press the [STEP] key again.

Memory System Operation

MEMORY OPERATION ON SPLIT-FREQUENCY MEMORY CHANNELS (CHANNEL DUP 001 TO DUP 020)

Split frequency memories are often helpful when using the FT-100D on a DX-pedition, or for DX operation on the 7 MHz band.

MEMORY CHANNEL STORAGE

1. Set VFO-A to the required receiving frequency and mode, and set VFO-B to the required transmit frequency and mode.



It is also acceptable to store the transmit frequency on VFO-A and the receive frequency on VFO-B, if you prefer. In this case, in step, above, press the [A](V>M) key to set up the appropriate Tx/Rx relationship between the two VFO's.

2. Recall the VFO-A (*receiving*) frequency.
3. Press the [FUNC] key, as needed, to recall Operating Function Row 2 [V>M, M>V, RPT, REV], then press the [A](V>M) key momentarily to enter the “Memory Check” mode. The frequency stored (if any) on the current memory channel will be shown in the display.
4. Rotate the **SELECT** knob to select the channel (within the special Group “DUP 001” to “DUP 020”) on which you wish to store the current frequency data.
5. Press and hold the [A](V>M) key for ½ second until you hear a double beep, which confirms that the split frequency information has been stored into the chosen memory location.

SPLIT MEMORY CHANNEL RECALL

1. If you currently are in the VFO tuning mode, press the [VFO/MR] key once to enter the “Memory” mode (the “MEM” icon will appear on the display).
2. To select another memory channel, turn the **SELECT** knob.
3. On the split-frequency memories, when you transmit, you will observe the frequency display changing to reflect the independent transmit frequency stored in memory.
4. Press the [VFO/MR] key to return to the VFO mode (the “MEM” indicator will be replaced by “V-A” or “V-B”).

Memory System Operation

MEMORY OPERATION ON HOME CHANNELS (CHANNELS HOM 001 TO HOM 004)

Four special one-touch HOME channels are available, for special frequencies you use often. Separate HOME channels are available for HF (HOM 001: any frequency between 1.8 and 29.7 MHz), 50 MHz (HOM 002), 144 MHz (HOM 003), and 430 MHz (HOM 004).

These memories may prove particularly useful for monitoring propagation beacons, providing one-touch recall of the beacon frequencies for quick checks of band conditions.

HOME CHANNEL STORAGE

1. Tune the desired frequency, and set the operating mode and bandwidth.
2. Press the **[FUNC]** key, as needed, to recall Operating Function Row 2 [**V>M**, **M>V**, **RPT**, **REV**], then press the **[A](V>M)** key momentarily to enter the "Memory Check" mode.
3. Rotate the **SELECT** knob to recall the HOME channel ("HOM 001" through "HOM 004") on which you wish to store the current frequency data.
4. Press and hold in the **[A](V>M)** key for ½ second until you hear a double beep, which confirms that the frequency information was successfully stored.

HOME CHANNEL RECALL

1. Press the **[HOME]** key momentarily to recall the Home Channel on the band group where you currently are operating (HF, 50 MHz, 144 MHz, or 430 MHz). The "HOM" icon will appear on the display.
2. Press the **[HOME]** key once more to return to the previously-used frequency (either a VFO frequency or a memory channel).

Memory System Operation

MEMORY MODE ACCESSORIES

MOVING MEMORY DATA TO VFO

Data stored on memory channels can easily be moved to a VFO, if you like.

1. Select the memory channel containing the frequency data to be moved to the current VFO (A or B).
2. Press the **[FUNC]** key, as needed, to recall Operating Function Row 2 [**V>M**, **M>V**, **RPT**, **REV**], then press and hold in the **[B](M>V)** key for ½ second until you hear a double beep. The data will now have been copied to the current VFO, although the original memory contents will remain intact on the previously-stored memory channel.

DELETING DATA FROM A MEMORY CHANNEL

Frequency data stored on a memory channel can be deleted from a memory channel, if desired. The deletion process is not a “hard” erasure, so if you erase a channel by mistake using this procedure, the memory channel contents can be recovered.

1. Select the memory channel containing the frequency data to be deleted.
2. Press the **[FUNC]** key, as needed, to recall Operating Function Row 2 [**V>M**, **M>V**, **RPT**, **REV**], then press and hold in the **[A](V>M)** key for ½ second until you hear a double beep. At this point, the memorized frequency and other data will disappear. The data is now “masked” and will not be available for operation.
3. To restore the masked frequency data, repeat steps 1 and 2 above. However, if you store new frequency information on a channel containing masked data, the masked data will be over-written and lost.



*In order to restore masked frequency data, the **SELECT** knob must not be set to the “fast” memory channel recall mode (whereby “empty” channels are skipped). If the FT-100 is in this “fast” mode, press the **[STEP]** key to toggle the **SELECT** knob to recall all memory channels.*

WeatherFax Monitoring

Monitoring of HF WeatherFax broadcasts is easily accomplished using the FT-100.

1. Before proceeding, be certain that the WeatherFax demodulator is properly connected to Pins 5 and 2 of the rear panel **DATA** jack.
2. Set the operating mode to USB by pushing the [**MODE**] key, as needed.
3. Set the transceiver to the VFO mode (unless a WeatherFax channel has been programmed into a Memory channel). Now, select the operating frequency of the station transmitting the WeatherFax broadcast. Note that, in the USB mode, the frequency you should program onto the display is typically 1.90 kHz *below* the station's "assigned" frequency. Thus for a WeatherFax station assigned to 8.682.0 MHz, tune to 8.680.1 MHz.
4. When the WeatherFax broadcast begins, no further operator intervention should be

rear of the transceiver is fixed, and cannot be adjusted.

Fine adjustments in the gray-scale and the frame alignment are accomplished using the computer and software connected to your WeatherFax demodulator.

Spectrum Scope Operation

The **SPECTRUM SCOPE** allows viewing of operating activity on 15 channels above and 15 channels below the current operating channel. The **Spectrum Scope** is available in the

To activate the **SPECTRUM SCOPE**:

1. Press and hold in the **[FUNC]** key for ½ second to enter the MENU mode, then rotate the **SELECT** knob to select MENU #15 (**SCOPE MONI**).
2. Rotate the **MAIN DIAL** to select the desired sweep mode:
 - Cont: The **SPECTRUM SCOPE** sweeps continuously.
 - Chec: The **SPECTRUM SCOPE** sweeps one cycle every 30 seconds.
 - Sgl: The **SPECTRUM SCOPE** sweeps just once whenever you press the **[FUNC]** key.
 - oFF: The **SPECTRUM SCOPE** is disabled.
3. Press the **[FUNC]** key momentarily to start the **SPECTRUM SCOPE**.
4. When the scope is in operation, the relative signal strength of stations on channels immediately adjacent to the current frequency will be indicated on the display.

Smart Search™ Operation

The Smart Search™ feature automatically stores frequencies where activity is encountered on the current band. When Smart Search™ is engaged, the transceiver quickly searches above and below your current frequency, storing active frequencies as it goes (without stopping on them even momentarily). These frequencies are stored in a special Smart Search™ memory bank, consisting of 40 memories (20 above the current frequency, 20 below the current frequency). This feature is available on the FM and AM modes. This feature is especially helpful when traveling, as you can instantly store active FM repeater frequencies without having to look up the frequencies in a reference book.

1. Set the **SQL** knob to the point where background noise is silenced. A typical setting, for effective Smart Search™ operation, will be at 12 o'clock or slightly clockwise from this position.
2. Set the VFO frequency on which you wish to begin the search (the Smart Search™ feature is available on the VFO mode only).
3. Press the **[FUNC]** key, as needed, to recall Operating Function Row 4 [SKP, SCN, DW, SCH], then press the **[D](SCH)** key to activate Smart Search™ (the "SCH" icon will become bold on the display).
4. Now press and hold in the **[D](SCH)** key for ½ second. The "SCH" icon will blink, and the FT-100 will sweep the current band once in each direction, starting on the current frequency. All channels where activity is present (up to 20 in each direction) will be loaded into the Smart Search™ memories. Whether or not all 40 memories are filled, the search will stop after one sweep in each direction.
5. Now you can turn the **SELECT** knob to select the Smart Search™ memories.
6. To disable Smart Search™ operation, press the **[D](SCH)** key momentarily (the "SCH" icon will again become faint).



- *Note that these memories are so-called "soft" memories; they will be lost if you initiate a new Smart Search™ sweep of the band.*
- *You can change the way in which Smart Search™ sweeps the band via MENU #15. See page 86 for details on the scanning options.*
- *The receiver's audio output and S-meter are disabled while sweeping the band.*

Scanning Operation

The FT-100D contains a wide variety of scanning capabilities. Whether you are in the VFO mode or one of the memory modes, scanning operation is fundamentally identical in all configurations, but with the following differences:

- In the VFO mode, scanning causes the transceiver to sweep up or down the band, ~~depending on the scanning mode selected.~~

- In the QMB mode, the scanner will scan only the QMB memory bank;
- In the Memory mode, the scanner will scan the programmed memories, and can be instructed to skip certain memories during scanning;
- In the Programmable Memory Scan (PMS) mode, the scanner will scan the band within user-programmed frequency limits.

SCANNING OPERATION

1. Set the **SQL** knob to the point where background noise is silenced. A typical setting, for effective scanning operation, will be at 12 o'clock or slightly clockwise from this position.
2. Set the transceiver into the operating configuration in which you wish to scan (VFO, Memory, QMB, etc.).
3. Press the **[FUNC]** key, as needed, to recall Operating Function Row 4 **[SKP, SCN, DW, SCH]**, then press and hold the **[B](SCN)** key for ½ second to start *upward* scan (toward higher frequencies or higher memory channel numbers).



*You may also press and hold in either the **[UP]** or **[DWN]** key on the microphone for ½ second to initiate upward or downward scanning, respectively.*

4. Rotate the **MAIN DIAL** or the **SELECT** knob counterclockwise to toggle the scanning direction *downward*.
5. The scanner will now cause the transceiver to increment in the chosen direction until a signal is detected. When a signal is encountered which opens the Squelch, the scanner will pause until the signal disappears (at the end of the other station's transmission), at which point the scanner will resume. While the transceiver is in the "Pause" condition, the decimal points in the frequency display area will blink. See "Scan-Resume Choices"

Scanning Operation

SCAN SKIP PROGRAMMING (MEMORY MODE ONLY)

Among the memories you have programmed, there may be some stations which you do not wish to scan. For example, weather broadcasts (which are transmitted continuously) will cause the scanner to stop, and such channels may be skipped so as to avoid this inconvenience.

To remove a channel from the scanning loop:

1. Recall the memory channel to be skipped.
2. Press the **[FUNC]** key, as needed, to recall Operating Function Row 4 [**SKP**, **SCN**, **DW**, **SCH**], then press the **[A](SKP)** key momentarily. The “SKP” icon will become Bold; this shows that this channel is now not included in the scanning loop.
3. Repeat steps 1 and 2 as many times as necessary to skip all the channels you do not wish to scan.
4. Initiate memory scanning, you will observe that the channels you marked to be skipped are not included in the scanning loop.
5. Press the **PTT** switch to stop the scan; you may now use the **SELECT** knob to step through the channels manually – one at a time – and you will observe that the “skipped” channels are, nonetheless, available for recall by manual means.
6. You may restore a previously-skipped channel to the scanning loop by selecting the channel manually, then pressing the **[A](SKP)** key momentarily so that the “SKP” icon becomes faint.

Scanning Operation

PROGRAMMABLE MEMORY SCAN (PMS) OPERATION

To limit scanning (or tuning) within a particular frequency range...

6

mable Memory Scanning (PMS) feature, which utilizes twenty special-purpose memories ("PGM 001" ~ "PGM 020"). The PMS feature is especially useful in helping you to observe any operating sub-band limits which apply to your Amateur license class.

PMS setup is simple to complete. First, store the upper and lower frequency limits of the range in a consecutive pair of PMS memories (i.e., "PGM 001" & "PGM 002", "PGM 003" & "PGM 004", etc.). For example, "PGM 003" might contain the lower edge and "PGM 004" the upper. Next recall the first memory of the pair that hold the range you want to scan or tune, then turn the **MAIN DIAL** knob or pressing the **SELECT** knob

Menu Operation

The FT-100's Menu System allows you to customize a wide variety of transceiver performance aspects and operating characteristics.

MENU SELECTIONS

1. Press and hold the **[FUNC]** key for $\frac{1}{2}$ second. The Menu Item number and a brief title for the Menu Item will appear in the display.
2. Rotate the **SELECT** knob to select the Menu Item you wish to work on.
3. When you have chosen the desired Menu Item number, rotate the **MAIN DIAL** to change

4. When you have made your selection, press the **[FUNC]** key momentarily to exit and resume normal mode.

Item #	Menu Item	Function	Available Values	Default
1	DIAL PULSE	Setting of MAIN DIAL Speed	100/200	200
2	BEEP	Enables/disables the key and button beeper	on/off	on
3	SCAN MODE	Select the desired Scan-Resume mode	tinE/buSy/StoP	tinE

Menu Operation

Item #	Menu Item	Function	Available Values	Default
31	CW-W FILT	Enable the CW signal path via the optional CW filter slot	on/oFF	oFF
		Enable the CW signal path via the		

Menu Operation

MENU MODE SELECTIONS AND SETTINGS

Menu Item 01 [DIAL PULSE]

Function: Setting of **MAIN DIAL** Speed.

Available Values: 100/200

Default: 200

You may choose between two speeds for the **MAIN DIAL** knob. Selecting “100” cuts the tuning rate in half compared to the default value.

Menu Item 02 [BEEP]

Function: Enables/disables the key and button beeper.

Available Values: on/off

Default: on

Enables/disables the beep that sounds when a front panel key or button is pressed.

Menu Item 03 [SCAN MODE]

Function: Select the desired Scan-Resume mode.

Available Values: tinE/buSy/StoP

Default: tinE

This Menu Item allows you to select your favorite method of scan-restart after the scanner has stopped on an incoming signal (when the squelch opens). The choices are:

tinE: The scanner will hold for a fixed length of time, set via Menu Item 05, then resume whether or not the other station is still transmitting.

buSy: The scanner will hold until the signal disappears, then will resume after one second.

StoP: The scanner will stop when a signal is received, and will not restart.

Menu Item 04 [SCAN SPEED]

Function: VFO Scan Speed.

Available Values: 10 ~ 100 ms

Default: 10 ms

This sets the scan dwell time (the time spent on each synthesizer step) during VFO scanning. This setting is enabled in the SSB, CW, and DIG modes only.

Menu Item 05 [RESUME]

Function: Set the delay time for scan, as described in Menu Item 03.

Available Values: 1 ~ 10 second

Default: 5 second

This Menu Item defines the length of time the scanner will hold on a frequency when in the “tinE” mode.

Menu Operation

MENU MODE SELECTIONS AND SETTINGS

Menu Item 06 [DW-TIME]

Function: Set the polling interval for the Dual Watch System.

Available Values: 1 ~ 10 second

Default: 5 second

This Menu Item defines the amount of time the Dual Watch System will dwell on VFO-A before checking VFO-B for activity.

Menu Item 07 [DCS CODE]

Function: Setting the DCS Code.

Available Values: 104 standard DCS codes.

Default: 023

The available DCS codes are shown in the chart.

DCS CODE													
023	025	026	031	032	036	043	047	051	053	054	065	071	
072	073	074	114	115	116	122	125	131	132	134	143	145	
152	155	156	162	165	172	174	205	212	223	225	226	243	
244	245	246	251	252	255	261	263	265	266	271	274	306	
311	315	325	331	332	343	346	351	356	364	365	371	411	
412	413	423	431	432	445	446	452	454	455	462	464	465	
466	503	506	516	523	526	532	546	565	606	612	624	627	
631	632	654	662	664	703	712	723	731	732	734	743	754	

Menu Item 08 [DCS ENC/DEC]

Function: Select "Normal" or "Inverted" DCS coding.

Available Values: tn-rn/tn-rr/tr-rn/tr-rr

Default: tn-rn

tn-rn (ENC: Normal, DEC: Normal)

tn-rr (ENC: Normal, DEC: Inverted)

tr-rn (ENC: Inverted, DEC: Normal)

tr-rr (ENC: Inverted, DEC: Inverted)

Keep this selection set with both parameters "Normal" (the default setting) unless you are certain that the other station(s) will be using "Inverted" DCS coding.

Menu Item 09 [ARTS BEEP]

Function: Select the ARTS beep mode.

Available Values: rAng/ALL/oFF

Default: ALL

rAng: A high-tone beep will sound when the radio first detects that you are within range, and a low beep will sound when the other station goes out of range.

ALL: A high-tone beep will sound every time a polling transmission is received from the other station, and a low beep will sound *once* when the other station goes out of

Menu Operation

MENU MODE SELECTIONS AND SETTINGS

Menu Item 10 (CW ID)

Function: Enables/disables the CW identifier during ARTS operation.

Available Values: on/oFF

Default: oFF

Menu Item 11 (ID)

Function: Store the CW Identifier callsign. Up to 8 characters may be stored. The storage procedure is as follows:

1. Press the **SELECT** knob momentarily to initiate the CW ID storing.
2. Rotate the **MAIN DIAL** to select the first letter/number of your callsign, then press the **SELECT** knob momentarily to *save* the first letter/number and move to next entry place.
3. Repeat the previous step as necessary to complete your callsign.
4. Press the [**FUNC**] key to save your completed callsign and exit.

Menu Item 12 (TONE FREQ)

Function: Setting the CTCSS Tone Frequency.

Available Values: 39 standard CTCSS tones.

Default: 88.5 Hz

The available tones are shown in the chart.

CTCSS TONE FREQUENCY (Hz)							
67.0	69.3	71.9	74.4	77.0	79.7	82.5	85.4
88.5	91.5	94.8	97.4	100.0	103.5	107.2	110.9
114.8	118.8	123.0	127.3	131.8	136.5	141.3	146.2
151.4	156.7	162.2	167.9	173.8	179.9	186.2	192.8
203.5	210.7	218.1	225.7	233.6	241.8	250.3	-

Menu Item 13 (DIMMER SET)

Function: Setting the degree of dimming of the front panel display's brightness.

Available Values: 63 (Dim) ~ 1 (Bright)/oFF(Brightest test)

Default: oFF (Brightest setting)

Menu Item 14 (PEAK HOLD)

Function: Enabling/Disabling of the "Peak-Hold (0.5 second hold)" function of the meter.

Available Values: on/oFF

Default: oFF

Menu Item 15 (SCOPE MONI)

Function: Select the sweep mode for the SPECTRUM SCOPE feature.

Available Values: Cont/CHEC/SgL/oFF

Default: oFF

Cont: The scanner sweeps continuously.

Chec: The scanner sweeps one cycle every 30 seconds.

SgL: The scanner sweeps just once.

oFF: The scanner is disabled.

Menu Operation

MENU MODE SELECTIONS AND SETTINGS

Menu Item 16 [DSP MIC EQ]

Function: Set the DSP microphone equalization pattern.

Available Values: oFF/1/2/3

Default: oFF

This Menu Item allows you to tailor, via the DSP, the audio response of the transceiver to match your voice characteristics. This focuses the available power of the transceiver into the frequency spectrum occupied by your voice, thus increasing useful power output. This choices are:

OFF: This function is disabled.

- 1: High Cut (lower frequencies are emphasized)
- 2: Low Cut (higher frequencies are emphasized)
- 3: High/Low Cut (mid-range frequencies are emphasized)

Menu Item 17 [DSP NR]

Function: Setting the degree of DSP Noise Reduction.

Available Values: 1 ~ 16

Default: 7

A higher setting provides more noise reduction, with a slight loss of fidelity on the incoming signal.

Menu Item 18 [DSP LPF]

Function: Adjust the high-cut characteristics of the DSP LPF filter.

Available Values: 1000 ~ 6000 Hz

Default: 6000 Hz

This Menu Item determines the high-cut frequency of the DSP LPF filter in the SSB, AM, and FM modes. Best voice-mode interference rejection will usually be obtained with a

Menu Item 19 [DSP HPF]

Function: Adjust the low-cut characteristics of the DSP HPF filter.

Available Values: 100 ~ 1000 Hz

Menu Operation

MENU MODE SELECTIONS AND SETTINGS

Menu Item 20 [BPF WIDTH]

Function: Setting the bandwidth for the DSP CW audio filter.

Available Values: 60/120/240 Hz

Default: 240 Hz

This selection determines the bandwidth of the DSP CW peaking filter.

Menu Item 21 [HF TX PO]

Function: Setting the maximum power level for the HF band.

Available Values: 0 ~ 100

Default: 100



You can set the power output separately on SSB/CW/FM and FM by changing modes and re-adjusting this setting for the desired power level.

Menu Item 22 [50M TX PO]

Function: Setting the maximum power level for the 50 MHz band.

Available Values: 0 ~ 100 % (% of 100 Watts maximum PO)

Default: 100



You can set the power output separately on SSB/CW/FM and FM by changing modes and re-adjusting this setting for the desired power level.

Menu Item 23 [144M TX PO]

Function: Setting the maximum power level for the 144 MHz band.

Available Values: 0 ~ 100 % (% of 50 Watts maximum PO)

Default: 100



You can set the power output separately on SSB/CW/FM and FM by changing modes and re-adjusting this setting for the desired power level.

Menu Item 24 [430M TX PO]

Function: Setting the maximum power level for the 430 MHz band.

Available Values: 0 ~ 100 % (% of 20 Watts maximum PO)

Default: 100



You can set the power output separately on SSB/CW/FM and FM by changing modes and re-adjusting this setting for the desired power level.

MENU MODE SELECTIONS AND SETTINGS

Menu Item 25 (MIC GAIN)

Function: Set the Mic gain level for the SSB and AM modes.

Available Values: 0 ~ 100 %

Default: 50 %

Menu Item 26 (FM MIC GAIN)

Function: Set the Mic gain level for the FM mode.

Available Values: 0 ~ 100 %

Default: 50 %

Menu Item 27 (COMP LEVEL)

Function: Set the compression level for the AF speech processor in the SSB/AM modes.

Available Values: 0 ~ 100 %

Default: 50 %

Menu Item 28 (AFSK LEVEL)

Function: Adjust the audio input level from the TNC during AFSK operation.

Available Values: 0 ~ 100 %

Default: 50 %

Menu Item 29 (APO TIME)

Function: Select the Auto Power Off time (time before power goes off).

Available Values: oFF/1/2/3 hour

Default: oFF

Menu Item 30 (TOT TIME)

Function: Select the TOT time (the continuous transmission time that will be allowed).

Available Values: oFF/1 ~ 20 minutes

Default: 20 minutes

Menu Item 31 (CW-W FILT)

Function: Enable the CW signal path via the optional CW filter slot.

Available Values: on/oFF

Default: oFF

Menu Item 32 (AM/CW-N FILT)

Function: Enable the CW signal path via the optional CW-N filter or enable the AM signal path via the optional AM filter.

Available Values: oFF/300/6.0

Default: oFF

Menu Operation

MENU MODE SELECTIONS AND SETTINGS

Menu Item 33 [FM DEV]

Function: Select the maximum deviation for FM operation.

Available Values: HF 2.5/2.5/5.0 kHz

Default: HF 2.5 kHz

HF 2.5: FM maximum deviation is 2.5 kHz in the 29 MHz band; other amateur bands: 5.0 kHz.

2.5: FM maximum deviation is 2.5 kHz in all amateur bands.

5.0: FM maximum deviation is 5.0 kHz in all amateur bands.

Menu Item 34 [AFSK MODE]

Function: Select the mode and sideband (if applicable) in the AFSK mode

Available Values: rtty-L/rtty-U/PcT-L/PcT-U/PcT-F

Default: Pct-F

rtty-L: AFSK RTTY operation on the LSB mode

rtty-U: AFSK RTTY operation on the USB mode

PcT-L: 300 bps HF packet operation on the LSB mode.

PcT-U: 300 bps HF packet operation on the USB mode.

PcK-F: 1200/9600 bps FM packet operation.

Menu Item 35 [RTTY SHIFT]

Function: Selects 170, 425, or 850 Hz standard frequency shift for FSK RTTY operation.

Available Values: 170/425/850

Default: 170

Menu Item 36 [RTTY DISPLAY]

Function: Selects the type of display offset that appears during RTTY operation.

Available Values: nor/CAR

Default: nor

nor: Displays the RTTY BFO offset.

CAR: Displays the actual carrier frequency.

Menu Item 37 [PACKET RATE]

Function: Set the transceiver's circuitry for the Packet baud rate to be used.

Available Values: 1200 /9600 bps

Default: 1200 bps

MENU MODE SELECTIONS AND SETTINGS

Menu Item 38 (PKT DISPLAY)

Function: Define the displayed frequency offset during Packet operation.

Available Values: -3000 ~ +3000 Hz

Default: 2125 Hz

You can have the display show the (suppressed) carrier frequency or the center frequency between the two packet tones.

Menu Item 39 (PACKET TONE)

Function: Align the transceiver to the frequency of the tone pair defined by the TNC.

Available Values: 1170/1700/2125/2210 Hz

Default: 2125 Hz

The above designations of the available values represent the center frequency of the Packet tone pair during USB/LSB AFSK operation.

Menu Item 40 (HF RPT SHIFT)

Function: Set the magnitude of the Repeater Shift to be utilized when operating on the 28 MHz band.

Available Values: 0 ~ 10 MHz

Default: 100 kHz

Menu Item 41 (50 RPT SHIFT)

Function: Set the magnitude of the Repeater Shift to be utilized when operating on the 50 MHz band.

Available Values: 0 ~ 10 MHz

Default: 500 kHz

Menu Item 42 (144 RPT SHIFT)

Function: Set the magnitude of the Repeater Shift to be utilized when operating on the 144 MHz band.

Available Values: 0 ~ 10 MHz

Default: 600 kHz (Depends on transceiver version)

Menu Item 43 (430 RPT SHIFT)

Function: Set the magnitude of the Repeater Shift to be utilized when operating on the 430 MHz band.

Available Values: 0 ~ 10 MHz

Default: 5 MHz (depends on transceiver version)

Menu Operation

MENU MODE SELECTIONS AND SETTINGS

Menu Item 44 (144 ARS)

Function: Activate/deactivate the Automatic Repeater Shift when operating on the 144 MHz band.

Available Values: on/oFF

Default: on (depends on transceiver version)

Menu Item 45 (430 ARS)

Function: Activate/deactivate the Automatic Repeater Shift when operating on the 430 MHz band.

Available Values: on/oFF

Default: on (depends on transceiver version)

Menu Item 46 (KEYER TYPE)

Function: Select the keyer paddle operating mode.

Available Values: EL1/EL2/Bug

Default: EL2

This item selects the desired keyer emulation mode for the built-in electronic keyer:

EL1: Iambic keyer with ACS (Automatic Character Spacing) disabled. Weighting is user-selectable via the Menu Items 47 and 48.

EL2: Iambic keyer with ACS enabled. Weighting is user-selectable via the Menu Items 47 and 48.

Bug: Mechanical “bug” keyer emulation. One paddle produces “dits” automatically, while the other paddle manually produces “dahs”.

Menu Item 47 (DOT SIZE)

Function: Set the Dot:Space ratio for the built-in electronic keyer.

Available Values: 0 ~ 125 (0:1 ~ 12.5:1 Dot:Space)

Default: 10 (1:1 Dot:Space)

Menu Item 48 (DASH SIZE)

Function: Set the Dash:Space ratio for the built-in electronic keyer.

Available Values: 0 ~ 125 (0:1 ~ 12.5:1 Dash:Space)

Default: 30 (3:1 Dash:Space)

Menu Item 49 (CW-DELAY)

Function: Set the receiver recovery time during pseudo-VOX CW semi-break-in operation.

Available Values: 0 ~ 2.5 seconds

Default: 0.5 second

The recovery time may be adjusted in steps of 0.1 second. A longer delay may be preferable if you pause frequently while sending.

Menu Operation

MENU MODE SELECTIONS AND SETTINGS

Menu Item 50 [CW PITCH]

Function: Setting of the pitch of the CW sidetone, BFO offset, and IF/DSP CW filter center frequencies.

Available Values: 400/500/600/700/800 Hz

Default: 700 Hz

Menu Item 51 [CW BREAK-IN]

Function: Select the CW Break-in mode.

Available Values: FULL/SEni

Default: FULL

FULL: CW operation in the “Full Break-in” (“QSK”) operation.

SEni: The FT-100 allows the “Semi-Break-in” (pseudo-“VOX”) operation.

Menu Item 52 [KEYER SPEED]

Function: Set the sending speed for the built-in Electronic Keyer.

Available Values: 1 (slow) ~ 100 (high)

Default: 50

Menu Item 53 [QSK DELAY]

Function: Provide an envelope delay when using the built-in Electronic Keyer.

Available Values: 0 ~ 30 ms

Default: 5 ms

This Menu Item allows shifting of the entire CW transmission string in time, so as to avoid sequencing difficulties with external linear amplifiers, etc. The delay is applied to the entire keyed signal (no truncation on either “make” or “break”) to preserve the full values of weighting set via Menu Items 47 and 48.

Menu Item 54 [VOX GAIN]

Function: Set the gain of the VOX circuitry’s input audio detector.

Available Values: 0 (min) ~ 100 (max)

Default: 50

Set the VOX Gain to the level which quickly activates the transmitter, yet does not pick up extraneous noise in your operating room.

Menu Item 55 [VOX DELAY]

Function: Set the “hang time” for the VOX circuitry.

Menu Operation

MENU MODE SELECTIONS AND SETTINGS

Menu Item 56 (SQL/RF GAIN)

Function: Select the operation of the front panel's SQL/RF knob.

Available Values: Sql/rF

Default: Sql

Menu Item 57 (LOCK MODE)

Function: Select the operation of the front panel's [LOCK] key.

Available Values: diAL/PAnEL

Default: diAL

DiAL: Locks **MAIN DIAL** knob only.

PAnEL: Locks all front keys and knobs (except the [LOCK] key itself!).

Menu Item 58 (AM&FM CLICK)

Function: Enabling/disabling the **MAIN DIAL** knob on the AM and FM modes.

Available: on/oFF

Default: on

Menu Item 59 (MIC SW SET)

Function: Assign the Microphone's Function switch.

Available Values: 1/2/3/4

Default: 1 (**P** button=VFO/MR, **P1** button=BAND DOWN, **P2** button=BAND UP)

Option	P Button	P1 Button	P2 Button
1	VFO/MR	BAND DOWN	BAND UP
2	VFO/MR	SEARCH	MODE
2	STEP	BAND DOWN	BAND UP
4	STEP	SEARCH	MODE

Menu Item 60 (NB LEVEL)

Function: Setting the degree of IF Noise Blanking.

Available Values: 1 ~ 16

Default: 10

A higher setting provides more noise blanking action, with a slight loss of fidelity on the incoming signal.

Menu Item 61 (TUNER/ATAS)

Function: Select the device (FC-20, or ATAS-100) to be controlled via the front panel's [B](TUN) key.

Available Values: oFF/AtAS-1/AtAS-2/tunEr

Default: oFF

oFF: The [B](TUN) key is disabled.

AtAS-1: The [B](TUN) key will activate the optional ATAS-100 on both antenna ports (an external diplexer will be required).

AtAS-2: The [B](TUN) key will activate the optional ATAS-100 (on the HF/50 port).

tunEr: The [B](TUN) key will activate the optional FC-20.

MENU MODE SELECTIONS AND SETTINGS

Menu Item 62 (RX LSB CAR)

Function: Set the Rx Carrier Point for LSB.

Available Values: +500 ~ -200 Hz (In 10 Hz steps)

Default: 0 Hz

Changing this value is analogous to rotating the IF Shift control, allowing you to preset the frequency response of the receiver's IF passband during LSB operation.

Menu Item 63 (RX USB CAR)

Function: Set the Rx Carrier Point for USB.

Available Values: +500 ~ -200 Hz (In 10 Hz steps)

Default: 0 Hz

Changing this value is analogous to rotating the IF Shift control, allowing you to preset the frequency response of the receiver's IF passband during USB operation.

Menu Item 64 (TX LSB CAR)

Function: Set the Tx Carrier Point for LSB.

Available Values: +500 ~ -200 Hz (In 10 Hz steps)

Default: 0 Hz

This is the same function as that of Menu Item 62, as applied to your voice response on LSB (Tx). The effect may be difficult to discern, however, depending on the setting of the TX Equalizer via Menu Item 16.

Menu Item 65 (TX USB CAR)

Function: Set the Tx Carrier Point for USB.

Available Values: +500 ~ -200 Hz (In 10 Hz steps)

Default: 0 Hz

This is the same function as that of Menu Item 63, as applied to your voice response on USB (Tx). The effect may be difficult to discern, however, depending on the setting of the TX Equalizer via Menu Item 16.

Menu Item 66 [5167.5 kHz]: U.S.A. Version only

Function: Enable Tx/Rx operation on the Alaska Emergency Channel, 5167.5 kHz.

Available Values: on/off

Default: off

When this Menu Item is set to on, the spot frequency of 5167.5 kHz will be enabled. To get to this frequency, use the **SELECT** knob to navigate; the Alaska Emergency Channel will be found between the Memory channel "300" and "DUP 001."

Note: Use of this frequency is restricted to amateurs operating in (or within 92.6 km of) the U.S. State of Alaska, and it is to be used for emergency communications only (involving the immediate protection of life or property).

CAT System Programming

The FT-100's **CAT** System allows the transceiver to be controlled by a personal computer. This allows multiple control operations to be fully automated as a single mouse click, or it allows a third-party software package (such as contest logging software) to communicate with the FT-100 without (redundant) operator intervention.

The Optional **CAT** Interface Cable **CT-62** is a connection cable for the FT-100 and your computer. The **CT-62** has a built-in level converter, allowing direct connection from the rear panel ACC Cable Pigtail to the serial port of your computer, without the need for an external RS-232C level converter box.

Yaesu Musen does not produce **CAT** System operating software, due to the wide variety of personal computers, operating systems, and applications in use today. However, the FT-100 (and other Yaesu products) are widely supported by third-party software packages, and we recommend that you contact your dealer for advice, or check advertisements in amateur radio journals. Most software vendors also have Home Pages on the World Wide Web which contain a wealth of information on the features and radio support for their software packages.

The information presented in this section will allow the programmer to understand the command structure and encodes used in the FT-100's **CAT** System.

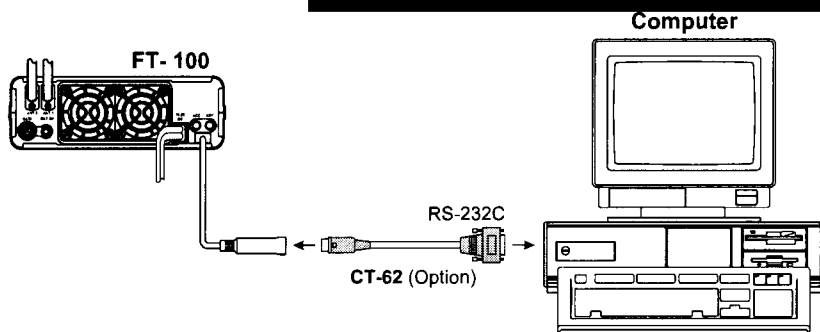

CAT System Programming

CAT DATA PROTOCOL

All commands sent from the computer to the transceiver consist of five-byte blocks, with up to 200 ms between each byte. The last byte in each block is the *instruction opcode*, while the first four bytes of each block are arguments (either parameters for that instruction, or dummy values required to pad the block out to five bytes). Each byte consists of 1 start bit, 8 data bits, no parity bit, and two stop bits.

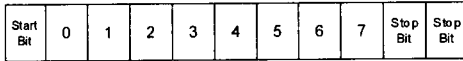

⇐ CAT DATA BYTE FORMAT

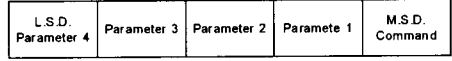

⇐ CAT 5-BYTE COMMAND STRUCTURE

There are 13 instruction opcodes for the FT-100, listed in the chart on next page. Many of these opcodes are On/Off toggle commands for the same action (e.g. “PTT On” and “PTT Off”). Most of these commands require some parameter or parameters to be set. Irrespective of the number of parameters present, every Command Block sent *must* consist of five bytes.

Accordingly, any **CAT** control program must construct the five-byte block by selecting the appropriate instruction opcode, organizing the parameters as needed, and providing unused “dummy” argument bytes to pad the block to its required five-byte length (the dummy bytes can contain any value). The resulting five bytes are then sent, opcode last, from the computer to the FT-100 CPU via the computer’s serial port and the transceiver’s ACC Cable Pigtail.

All **CAT** data values are hexadecimal.

Note that, unlike most other Yaesu transceivers, the FT-847 serial data cable is a “null modem” (“crossed”) type, not a “straight” serial data cable.

CONSTRUCTING AND SENDING CAT COMMANDS

Example #1: Set the VFO frequency to 439.70 MHz

- Per the **CAT** command table, the opcode for “Set Frequency” is **0A** (set by the “P1” command byte). Placing the opcode into the 5th data bit position, we then enter the frequency into the first four data bit positions:

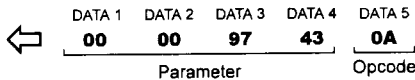

Send these five bytes to the transceiver, in the order shown above.

Example #2: Turn the Split Mode “ON”

- Per the **CAT** command table, the opcode for “Split On/off” is **01** (hex). Placing the opcode into the 5th data bit position, we then enter dummy values into all other parameter locations:

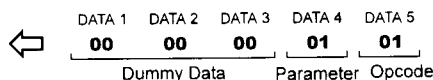

Opcode Command Chart

Command Title	Opcode	Parameter	Parameter			Notes
SPLIT on/off	01	P1	※	※	※	P1=00: Split OFF P1=01: Split ON
VFO Mode	05	P1	※	※	※	P1=00: VFO-A P1=01: VFO-B
Set Frequency	0A	①	②	③	④	① ~ ④: Frequency Digits 0A, 43, 42, 00, 00 = 432.100 MHz
Operating Mode	0C	P1	※	※	※	P1=00: LSB P1=01: USB P1=02: CW P1=03: CW-R P1=04: AM P1=05: DIG P1=06: FM P1=07: W-FM
PTT on/off	0F	P1	※	※	※	P1=00: PTT OFF (RX) P1=01: PTT ON (TX)
Status Update	10	P1	※	※	※	Note 1
Repeater Shift	84	P1	※	※	※	P1=00: Simplex P1=01: "Minus" Shift P1=02: "Plus" Shift
Filter Selection	8C	P1	※	※	※	P1=00: 2.4 kHz P1=01: 6.0 kHz P1=02: 500 Hz P1=03: 300 Hz
CTCSS Tone	90	P1	※	※	※	Note 2
DCS Code	91	P1	※	※	※	Note 3
CTCSS/DCS Mode	92	P1	※	※	※	P1=00: CTCSS/DCS OFF P1=01: CTCSS ENC ON P1=02: CTCSS TENC+DEC ON P1=03: DCS (ENC+DEC) ON
Read Meter	F7	※	※	※	※	Note 4
Read Status Flags	FA	01	※	※	※	Note 5

CAT System Programming

Note 1: Status Update

RYTE	Status	Comment
------	--------	---------

CAT System Programming

Note 2: CTCSS Tone

Freq (Hz)	P1	Freq (Hz)	P1	Freq (Hz)	P1
-----------	----	-----------	----	-----------	----

Note 4: Read Meter

- +0 → MSW1 (Microphone Switch 1): C0h = ACC, 90h = UP, 60h = DOWN, 30h = PTT
- +1 → FWD (Tx Forward Power): 00h ~ FFh
- +2 → REV (Tx Reverse Power): 00h ~ FFh
- +3 → S (S-meter Level): 00h ~ FFh
- +4 → MIC (Microphone Level): 00h ~ FFh
- +5 → NOISE (Squelch Level) : 00h ~ FFh
- +6 → MSW2 (Microphone Switch 2): 90h = P2, 60h = P1, 30h = P
- +7 → TEMP (Final Transistor Temperature): 00h ~ FFh
- +8 → ALC (ALC Level): 00h ~ FFh

Note 5: Read Status Flags

- | | | |
|-------------|--------------------------------------|---|
| +0 Status 0 | Status 0 | Status 1: |
| +1 Status 1 | Bit 0 → SPLIT: 1 = on, 0 = off | Bit 0 → Not Used |
| +2 Status 2 | 1 → Not Used | 1 → MR CHK: 1 = on, 0 = off |
| +3 Status 3 | 2 → TUNE: 1 = activate, 0 = wait | 2 → B VFO: 1 = VFO B on, 0 = VFO B off |
| +4 Status 4 | 3 → CAT IN: 1 = on, 0 = off | 3 → QMB: 1 = on, 0 = off |
| +5 Status 5 | 4 → Not Used | 4 → M TUNE: 1 = on, 0 = off |
| +6 Status 6 | 5 → POWER: 1 = on, 0 = off | 5 → VFO: 1 = VFO Mode, 0 = other Mode (such as QMB Mode) |
| +7 Status 7 | 6 → MUTE: 1 = on, 0 = off | 6 → MEM: 1 = Memory Mode, 0 = other Mode (such as VFO Mode) |
| | 7 → TX IN: 1 = on (Tx), 0 = off (Rx) | 7 → SRCH: 1 = Smart Search on, 0 = Smart Search off |

Status 2:

- Bit 0 → FAST: 1 = on, 0 = off
- 1 → TUNER: 1 = on, 0 = off
- 2 → BKMR: 1 = Vacant Memory Channels are skipped when recalling the Memory Channel
0 = All Memory Channel recalled when recalling the Memory Channel
- 3 → LOCK: 1 = Main Dial lock on, 0 = Main Dial lock off
- 4 → SQLSC: 1 = on, 0 = off
- 5 → UPSCN: 1 = Up Scan, 0 = Down Scan
- 6 → MEM: 1 = Memory Mode, 0 = other Mode (such as VFO Mode)
- 7 → SRCH: 1 = Smart Search on, 0 = Smart Search off

Status 3:

- Bit 0 → 1 MHz: 1 = 1 MHz Up/Down on, 0 = 1 MHz Up/Down off
- 1 → 10 MHz: 1 = 10 MHz Up/Down on, 0 = 10 MHz Up/Down off
- 2 → FMLOC: 1 = FM auto lock on, 0 = FM auto lock off
- 3 → Not Used
- 4 → CATTX: 1 = Tx on CAT command, 0 = Rx on CAT command
- 5 → NOTX: 1 = Tx Inhibit on, 0 = Tx Inhibit off
- 6 → KEYUP: 1 = Key is up,
0 = Key is pressed
- 7 → PTTWA: 1 = PTT waiting on, 0 = PTT waiting off

Status 4:

- Bit 0 → Not Used
- 1 → DSPBP: 1 = DSP BPF on, 0 = DSP BPF off
- 2 → DSPNT: 1 = DSP NOTCH on, 0 = DSP NOTCH off
- 3 → DSPNR: 1 = DSP Noise Reducer on,
0 = DSP Noise Reducer off
- 4 → ALOCK: 1 = Panel Lock on, 0 = Panel Lock off
- 5 → GROUP: 1 = Memory Channel Group on,
0 = Memory Channel Group off
- 6 → PRGM: 1 = PMS on, 0 = PMS off
- 7 → Not Used

Status 5:

- Bit 0 → ARTS: 1 = ARTS on, 0 = ARTS off
- 1 → BKIN: 1 = CW Break-in on, 0 = CW Break-in off
- 2 → KEYSR: 1 = CW Keyer on, 0 = CW Keyer off
- 3 → AUTTX: 1 = DSP Noise Reducer on,
0 = DSP Noise Reducer off
- 4 → Not Used
- 5 → Not Used
- 6 → WAIT: 1 = Antena Tuner Waiting,
0 = Antenna Tuner Activate
- 7 → HI SWR: 1 = HI SWR on, 0 = HIGH SWR off

Status 6:

- Bit 0 → DULON: 1 = Dual Watch Operation on,
0 = Dual Watch Operation off
- 1 → DULCK: 1 = Dual Watch is Checking, 0 = Not checking
- 2 → Not Used
- 3 → BUSY: 1 = BUSY on, 0 = BUSY off
- 4 → Not Used
- 5 → ACCS: 1 = ACC Slow, 0 = other state (such as ACC A)

Status 7:

- Bit 0 → SIDE: 1 = CW Sidetone on, 0 = CW Sidetone off
- 1 → MUFST: 1 = Menu Fast on, 0 = Menu Fast off
- 2 → Not Used
- 3 → Not Used
- 4 → Not Used
- 5 → PROC: 1 = AF Speech Processor on,

The FT-100's memory data is maintained, even when DC power is turned off, via a lithium backup battery with an estimated lifetime of approximately five years. No data essential to the fundamental operation of the transceiver is stored in "volatile" memory, so when the battery's voltage ultimately is depleted the transceiver will not be disabled; you will just observe that the memories will have disappeared.

In some cases of erratic operation, it may be advisable to reset the microprocessor to its factory default condition, so as to determine whether or not a part failure has caused improper action, as opposed to some operational error.

This section describes the procedures for two types of microprocessor resets.

RESET PROCEDURES

To reset the customized Menu settings to their factory defaults:

1. Turn the transceiver Off.
2. Press and hold in the [HOME] and [FUNC] keys; while holding them in, press and hold in the [PWR] switch for ½ second to turn the transceiver On.
3. Release all keys; the reset procedure is now complete.

To reset the VFO and memories, but leave the customized MENU settings as you have set them:

1. Turn the transceiver Off.
2. Press and hold in the [DSP] and [LOCK] keys; while holding them in, press and hold in the [PWR] key for ½ second to turn the transceiver On.
3. Release all keys; the reset procedure is now complete.

The suggestions below may help you recover from commonly-encountered operational difficulties.

In Case of Trouble ...

Transceiver will not turn on:

- Be sure your power supply is turned on.
- If power supply does not turn on, check power supply fuse(s).
- Check connections from DC power supply to ensure both ends of cable are securely connected.
- Check condition of fuses in DC cable.
- Check for poor mechanical connection at fuse holders in DC cable.

No audio output is being heard:

- Check position of **AF** (GAIN) control to be sure it is not fully counter-clockwise.
- Rotate **SQL** (SQUELCH) control fully counter-clockwise to ensure that audio is not being muted by normal SQUELCH operation.

If on FM mode, check to see if the "TSC" "DCS" "ART" or "MOS" features are enabled.

indicating that the CTCSS Decoder or DCS are On (thus muting audio). Go to Operating Function Row 3 [TON, DCS, ART] to disable these features.

- Check to see if an improper cable is connected to the **EXT SP** jack.
- Check to see if the microphone **PTT** or desk microphone **TX/STBY** switch is closed.

Signals appear on S-meter, but poor/low audio:

- Check to see if the DSP settings are improperly configured. Switch DSP Off to confirm.
- Check IF Shift control to be sure it is not fully clockwise or counter-clockwise.
- IF FM signals sound distorted, be certain you are not accidentally receiving in the AM

In Case of Trouble ...

Cannot transmit:

- Check to ensure that coaxial cable is connected to correct **ANTENNA** jack.

operating mode is properly set.

- Check to ensure that the operating frequency is within an amateur band (if you see an “*ERROR*” message).
- Check to ensure that any FM repeater shift is not causing transceiver to attempt to transmit outside an amateur band (if you see an “*ERROR*” message).

General transmitter difficulties:

SSB/AM Modes

- Check setting of MIC GAIN (MENU #25 for SSB/AM, MENU #26 for FM), to be sure it is not set to zero.
- Check position of “TX PO” Menu items (MENU #21~24), to be sure they are not set to

In Case of Trouble ...

FM Mode

- Check setting of FM MIC GAIN per MENU #26.
- Check operation of PTT switch to ensure that the “TX” icon is appearing. See previous suggestions, if not.
- Check position of “TX PO” Menu items (MENU #21~24), to be sure they are not set to zero.
- If repeater cannot be accessed, ensure that any required CTCSS Encoder Tone or DCS code is properly set. Contact repeater administrator or repeater information directory if tone data is not known.
- If you are reported to be slightly “off frequency,” check to ensure that frequency is properly set (change synthesizer channel step per page 35 if proper frequency cannot be set using **MAIN DIAL** or **SELECT** knob).
- If no repeater shift takes place, check settings of MENU #40 (HF RPT SHIFT), #41 (50 RPT SHIFT), #42 (144 RPT SHIFT), or #43 (430 RPT SHIFT).
- If no Automatic Repeater Shift, check settings of MENU #44 (144 ARS) or #45 (430 ARS).

DATA Modes

- Check position of “TX PO” Menu items (MENU #21~24), to be sure they are not set to zero.
- On RTTY, ensure that you do *not* have TNC’s “FSK” keying output (closure to ground to shift) connected to FT-100D’s (AFSK) “DATA IN” input pin.
- Ensure that PTT line is properly connected to FT-100D **DATA** jack.
- Ensure that “TX AUDIO” output level from TNC is properly set.
- Ensure that MENU #28 (AFSK LEVEL) is properly set.
- On FM Packet, ensure that the Baud Rate is properly set via MENU #37.
- On multi-tone Data modes, ensure that both tones fall within IF passband of receiver and/or transmitter. Adjust tones at TNC, if not.

Blank display or erratic microprocessor function:

- If front panel switches do not respond, ensure that [LOCK] switch has not been pushed.

CAT data transfer problems:

- Ensure that the software and computer COM port settings are the same as the setting of the **CAT** System baud Rate: 4800 bps.
- Ensure that any contest or logging software used supports the FT-100D, and that the “Radio Control” protocol is enabled on the software.

Having Too Much Fun:

Operation normal! Thank you for choosing the FT-100D!

Installation of Optional Accessorise

OPTIONAL FILTERS XF-117CN/XF-117A

1. Turn the transceiver's power off by pressing and holding in the [PWR] switch for ½ second, and disconnect the DC cable from the transceiver's DC cable pigtail.
2. Referring to Figure 1, remove the six screws affixing the top case of the transceiver, and remove the top case; disconnect the speaker's connector when you remove the top case, and disconnect the front panel of the transceiver. Remove the **MIC** connector at the same time.
3. Refer to Figure 3, and remove the six screws which affix the circuit board to the chassis. Remove the four coaxial cables shown, as well as the two flat cables, so as to allow the board to be folded forward.
4. Again refer to Figure 2 for the mounting locations for the I.F. filters. Press the filter(s) to be installed into the appropriate slot(s) on the circuit board.
5. Fold the circuit board forward, and solder the pins of the filter(s) to the circuit board. Trim off any excess length.
6. Fold the circuit board back into its normal position. Replace the six mounting screws, along with the four coaxial cables and two flat cables. Be careful to observe the proper color-coding on the coaxial cables, per Figure 3.
7. Replace the microphone connector and front panel. Replace the top case (remember to replace the speaker connector), attach the DC cable, and turn the transceiver On by pressing and holding in the [PWR] switch for ½ second.
8. Refer to the chart, and change the settings of MENU #32. For each filter installed, the corresponding MENU Item must be set to "On."
9. Filter installation is now complete.

Menu #32	
XF-117A	6.0
XF-117CN	300

Installation of Optional Accessorise

OPTIONAL FILTERS XF-117CN/XF-117A

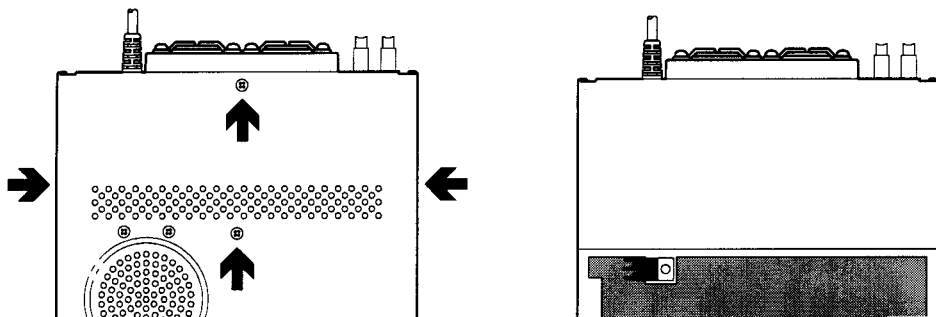

This device complies with Part 15 of the FCC rules.
Operation is subject to the condition that this device
does not cause harmful interference.



Copyright 2000
Yaesu Musen Co., Ltd.
All rights reserved.

No portion of this manual
may be reproduced
without the permission of
Yaesu Musen Co., Ltd.

Printed in Japan

























0004g-0Y



FT-100 Display Icon Summary

YAESU USA

This document shows the various display icons used in the Yaesu FT-100 transceiver. Included is a brief description of each icon, and where applicable, the corresponding page number of the FT-100 Operating Manual where more detailed information can be found.

 ANT	 APO	 ART	 DBF	 CLR	 DCS	 DW	 ERR	 LOK	 LOK
ATAS-100 is Tuning Page 64	Auto. Power Off is active Page 46	ARTS Mode is active Page 58	DSP Band Pass Fil Active Page 44	Clarifier (RT) is Active Page 39	Digital Coded Squelch On Page 56	Dual-Watch Scan is active Page 81	Non-specific Error Message	Dial is Locked (AM/FM Click) Page 46	Dial & Panel Locked Page 38
 TMP	 ON	 RPT	 SCN	 SCH	 IFS	 SPL	 SWR	 TOT	 TUN
High Temperature Warning (1)	Power-up Initialization	F1M Repeater Mode Active Page 54	Scan mode Active Page 78	VFO Smart- Search Active Page 77	IF Shift Control Active Page 42	Split mode Active Page 59	High SWR Warning (1)	TX Time-Out Time Reached Page 59	FC-20 tuner is tuning Page 68
 MENU	 DNF	 DNR	 OFF	(1) Continued use of the FT-100 while the Temperature or SWR Icon is shown may damage the transceiver. (2) This icon indicates that the selected transmitter frequency is invalid. No RF output is produced during this condition.					
Setting Menu Active Page 82	DSP Notch Filter Page 45	DSP Noise Reduction On Page 45	TX Inhibit (2)						