

INSTRUCTION

MANUAL

FL-400

For Service Manuals Contact
MAURITRON TECHNICAL SERVICES
8 Cherry Tree Rd, Chinnor
Oxon OX9 4QY

Tel: 01844-351694 Fax: 01844-352554
Email: enquiries@mauritron.co.uk

YAESU MUSEN CO., LTD.

TOKYO JAPAN

GENERAL

The model FLdx400/500 SSB Transmitter is a precision built, compact, high performance desk top SSB transmitter with CW, AM, LSB and USB modes of operation. FSK operation can be installed with minor modification. On all modes, except AM, this transmitter works at an input of 240 watts on all bands through 80 to 10 meters. The AM mode consists of transmitted carrier and one sideband. The SSB is generated by a MECHANICAL FILTER.

SPECIFICATIONS

Type of emission	CW, AM, SSB (upper/lower selectable), FSK option
Operation	VOX, PTT (push-to-talk), and MOX
Power input	240 watts PEP SSB & CW, 75 Watts AM
Output impedance	50 to 120 ohms
Frequency range	3.5-4.1MHz, 6.9-7.5MHz, 13.9-14.5MHz, 20.9-21.5MHz, 27.9-28.5MHz, 28.5-29.1MHz, 28.9-29.5MHz, 29.5-30MHz.
Frequency stability	100 Hz after warm-up for 10% drift of line voltage.
Carrier suppression	50 db below peak output
Sideband suppression	50 db below peak output at 1000 Hz
Distortion product	better than 30 db
Audio response	6 db at 300 to 2700 Hz
Power requirement	100/110/200/220/237 V AC 50/60 cps, 350 watts
Cabinet size	6 7/8" High, 14 7/8" Wide, 10 7/8" Deep
Net weight	18 Kgs/35 lbs

TUBE AND DIODE COMPONENTS

6AN8	1 speech amplifier	6U8	1 carrier OSC. & antitrip amplifier
1S1007	4 balanced modulator	12AU6	1 sideband oscillator
6U8	1 VOX amplifier, relay	6BA6	1 IF amplifier
SH-1	2 antitrip rectifier	6CB6	1 VFO mixer
12AT7	1 sideband mixer	6JS6C	2 linear amplifier
6AW8A	1 heterodyne osc. & mixer	SD-1	4 rectifier
12BY7A	1 driver	SH-1	2 automatic level control
SH-1	1 bias rectifier	3SK22G	2 VFO and buffer
1S1007	1 output rectifier	2SC372	1 VFO amplifier

IMPORTANT

Do not operate the equipment before you are completely familiar with the instructions in this manual. The block diagram and circuit description will provide you with a better understanding of this transmitter.

BLOCK DIAGRAM

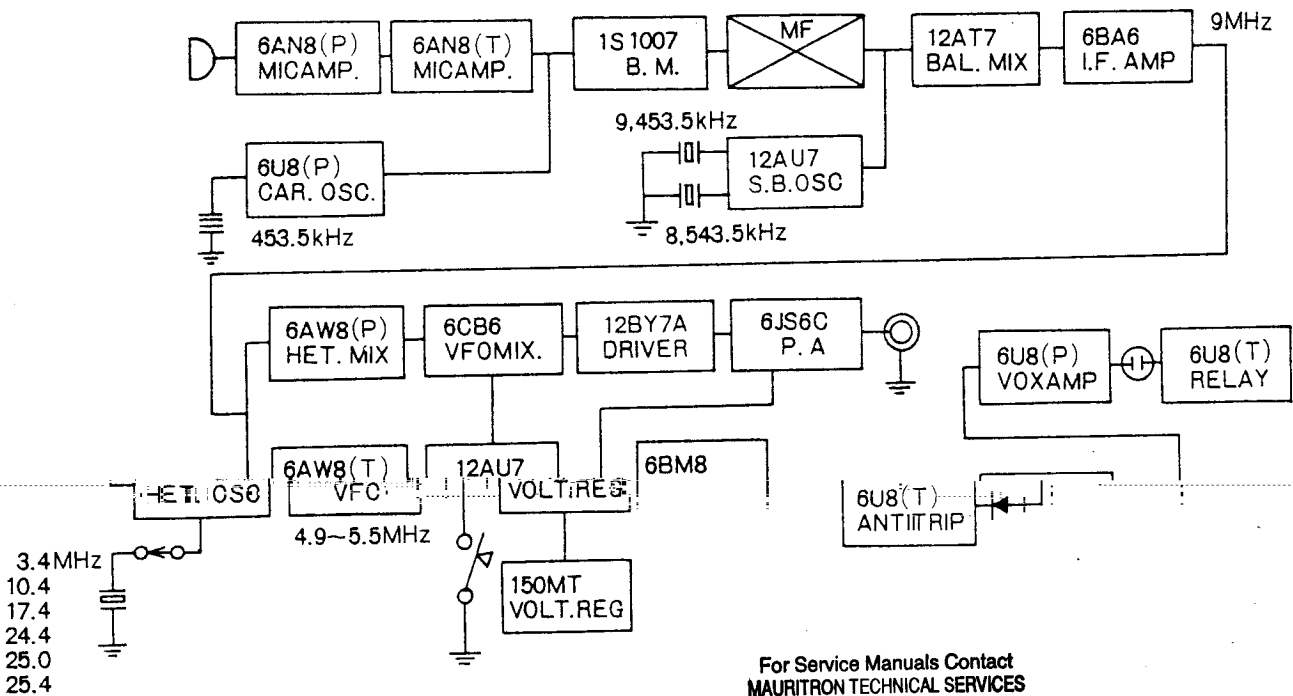

For Service Manuals Contact
MAURITRON TECHNICAL SERVICES
 8 Cherry Tree Rd, Chinnor
 Oxon OX9 4QY
 Tel:- 01844-351694 Fax:- 01844-352554
 Email:- enquiries@mauritron.co.uk

CIRCUIT DESCRIPTION

(1) SPEECH AMPLIFIER, CATHODE FOLLOWER

The pentode section of a 6AN8 tube is used as a speech amplifier. The amplified speech signal is coupled through the MIC GAIN control to the grid of the cathode follower, triode section of the same tube. A cathode follower circuit is used to match the low impedance of the diode balanced modulator. These circuits are inoperative in CW operation and SPOT.

(2) VOX AMPLIFIER, ANTITRIP AMPLIFIER, RELAY CONTROL

The speech signal is amplified and its output is coupled to the grid of a pentode section of 6U8, the VOX amplifier through the VOX GAIN control. The signal thus amplified is then fed to the neon lamp which conducts with speech signal to deliver positive voltage to the control grid of relay tube. This DC voltage is directly coupled to the grid of the relay control tube to control the relay with the speech signal. The relay control tube is cathode biased by VR5 $3K\Omega$, R-28 100Ω to cut-off without DC voltage which is applied to the grid by speech signal. In PTT (push-to-talk) operation, the cathode of this tube is grounded through a 100 ohm resistor, by a switch on the microphone. On VOX OFF position, the cathode is also grounded through a 100 ohm resistor which closes the relay. The audio signal from the station receiver is coupled to the antitrip amplifier tube through the ANTITRIP control. Amplified signals are then rectified which makes the grid of the VOX amplifier tube positive, the tube conducts to lower its plate voltage, and prevent the relay from activation by the audio signal from the station receiver. In CW operation, 6.3 volts AC is applied to the grid of the VOX amplifier tube through the VOX GAIN control and a 270 K ohms resistor for BREAK-IN CW operation. The DELAY control on the front panel adjusts the dropout time of the relay.

(3) CARRIER OSCILLATOR, BALANCED MODULATOR, MECHANICAL FILTER

The carrier oscillator utilizes the pentode section of a 6U8 tube. Frequency is controlled by a quartz crystal matched to the MECHANICAL FILTER to place the carrier at a point which provides proper audio response and excellent carrier suppression. The balanced modulator circuit consists of four matched diodes with a carrier null potentiometer. A trimmer capacitor is used in conjunction with the potentiometer to balance out external circuit capacity. A MECHANICAL FILTER is used for the generation of the single sideband. Excellent carrier and unwanted sideband suppression is obtained through the use of the MECHANICAL FILTER.

(4) SIDE BAND MIXER, SIDE BAND OSCILLATOR

The upper sideband generated by the balanced modulator and the mechanical filter is then fed to the grid of the sideband mixer tube 12AT7. This balance mixer mixes the 455kHz upper sideband signal with either 8543.5kHz or 9453.5kHz signal from the sideband oscillator. The sum of the 455kHz and 8543.5kHz produces the upper sideband 9MHz IF signal. The difference between the 455kHz

(6) HETERODYNE MIXER, HETERODYNE OSCILLATOR

The pentode section of a 6AW8A tube is used as a mixer to combine the sum of the 9MHz IF signal and the heterodyne oscillator signal from the triode section of the same tube. The grid circuit of this mixer is grid-block-keyed for CW operation.

The frequency relation between mixer plate tuning circuit and crystal oscillator is as follows:

BAND	CRYSTAL OSC.	MIXER PLATE
	80 meters	not in operation
	40 "	3.4 MHz
	20 "	10.4 MHz
	15 "	17.4 MHz
	10A "	24.4 MHz
	10B "	25.0 MHz
	10C "	25.4 MHz
	100 "	26.0 MHz

For Service Manuals Contact
MAURITRON TECHNICAL SERVICES
 8 Cherry Tree Rd, Chinnor
 Oxon OX9 4QY
 Tel: 01844-351694 Fax: 01844-352554
 Email: enquiries@mauritron.co.uk

For the auxiliary band operation, the heterodyne crystal frequency in MHz is calculated as follows:

$$X = \text{band frequency} + 5.4 - 9 \text{ MHz}$$

The band frequency is every megahertz and 500kHz.

For example, to determine the heterodyne crystal frequency to cover 14.832 MHz is calculated as follows:

$$X = 14.832 + 5.4 - 9 = 10.9 \text{ MHz}$$

(7) VFO MIXER, VFO OSCILLATOR

As a VFO mixer, a 6BC6 is used to combine heterodyne mixer output and VFO signal which is delivered from the VFO tube, 6X407. The difference between the two is now the transmitted frequency. The temperature compensated VFO circuit will provide excellent frequency stability. External VFO can be used by a switch to: Transceive or fixed crystal controlled operation.

(8) DRIVER, FINAL LINEAR AMPLIFIER

The driver stage uses a 6BN7A tube as a linear voltage amplifier. The grid of this stage is biased to cut-off in stand-by and the bias is removed by the keying or transmitting. The final linear amplifier utilizes two 6JS6C as class AB linear amplifier. This tube has high power output with a relatively low plate voltage. The amplifier is controlled by the capacitive bridge system with a variable capacitor connected from the plate of the tube to the bottom of the grid circuit. The grid of this tube is also biased to cut-off in stand-by and correct bias is supplied for transmit. The amplifier output is a shunt fed pi network capable of working into 50 to 120 ohm load on all bands.

The output side of the pi network is connected to a diode rectifier through the voltage divider to measure the relative power output. In SSB operation, the automatic level control is connected to the grid circuit to prevent overdrive. When RF drive voltage to the final tubes becomes sufficient to drive the grids positive, the grids begin to draw current and the signal is detected. This produces an audio envelope. The audio is rectified by the ALC rectifier, which in turn produces a negative DC voltage. The voltage is filtered and is used to control the gain of V3. The ALC voltage controls the gain of V3 and is grounded by the MODE switch in CW. The ALC voltage is also grounded by the MODE switch in TUNE positions. This system allows a high average level of modulation without distortion.

(9) POWER SUPPLY

Four silicon diodes are used for the high voltage rectifier instead of the conventional rectifier tube to improve the voltage regulation and for overall efficiency. 600 volts is available for the final plate supply and 300 volts for the low voltage circuits, screen grids of the final tube and the plate supply for VFO, sideband oscillators are stabilized by a 6BM8 tube. Carrier oscillator and heterodyne oscillator supply is regulated by a gas diode VR-150MT. The power transformer has five windings including two primary windings. Connecting the primary in parallel or series, provides 100 volts or 220 volts operation possible.

(10) METERING, OPERATION SWITCH, ACCESSORY SOCKET

Metering is provided by a milliammeter connected to the meter switch which selects final cathode current, ALC and relative power output. The operation switch changes the bias voltage for each stage as follows:

TUBE	OPERATION	STAND-BY	SPOTTING
6AW8A	0 volts	-60 volts	0 volts
6CB6	"	"	"
12BY7	"	"	"
6JS6C	-40 volts approx.	"	-60 volts

Accessory socket provides the following functions;

pin	1	+150V
"	2	FSK input
"	3	antitrip input from the station receiver
"	4	connect to pin 5 on stand-by
"	5	connect to pin 4 on stand-by and pin 6 on transmit, grounded
"	6	connect to pin 5 on transmit
"	7	connect to ground on receive
"	8	connect to ground on receive

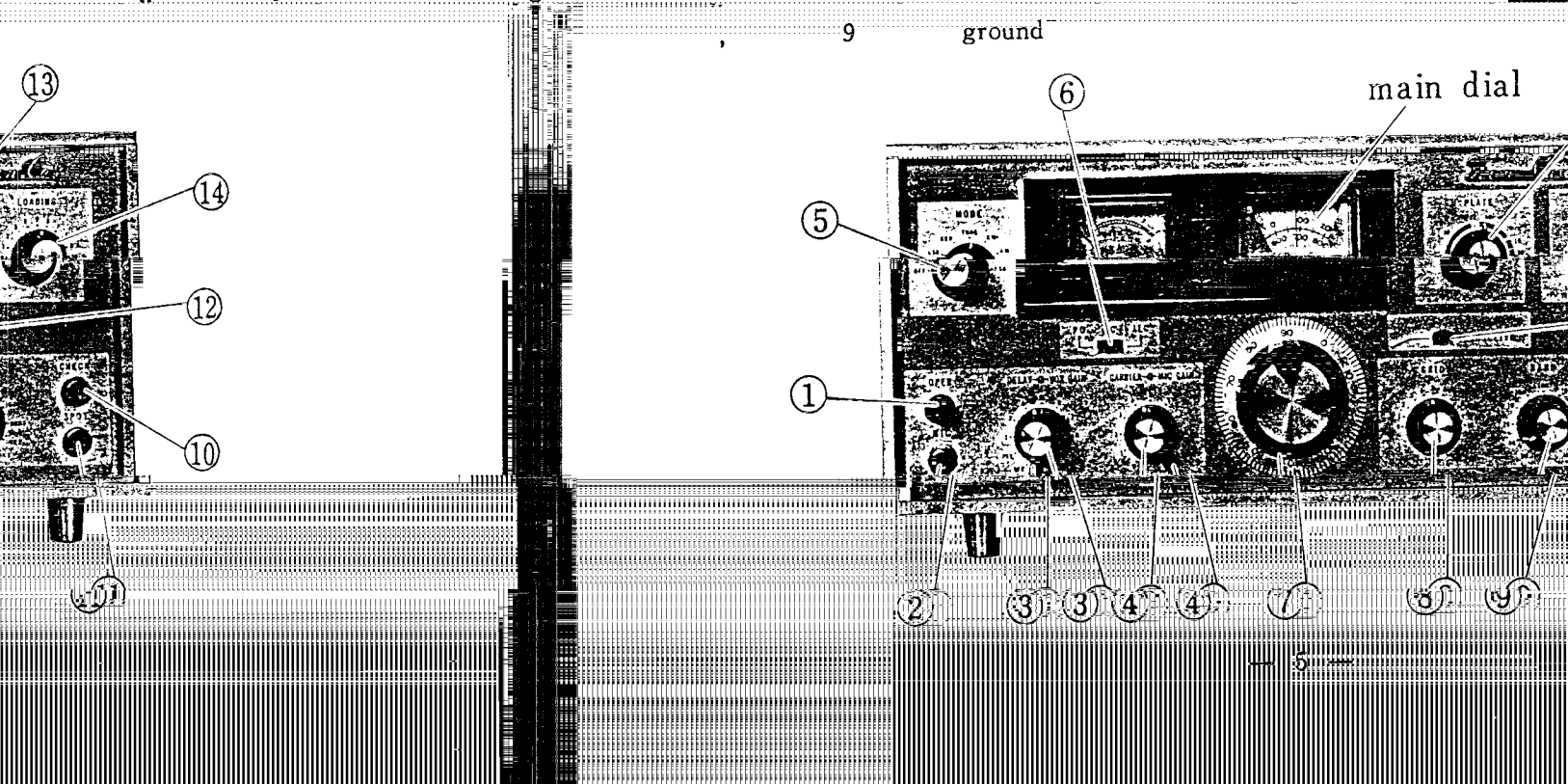

OPERATION

FUNCTION OF OPERATING CONTROLS

(1) OPER

With OPER switch pushed-in, voltage is supplied through the relay winding to the relay tube and the transmitter is ready to operate. For stand-by, push the switch to release from OPER condition.

(2) MIC

The microphone jack has three connections, these are, microphone input, push-to-talk circuit and ground connection. High impedance microphone should be used.

(3) DELAY/VOX GAIN

These controls set the operation level for the VOX relay; center knob controls input voltage for the VOX amplifier tube. In the OFF position, the cathode bias for the relay tube is removed to close the relay for manual operation with operation switch. On the PTT position, the relay does not work with speech, and thus push-to-talk operation is possible by removing cathode bias by a switch on microphone.

Outer lever is used to adjust the holding time of the relay for VOX and break-in CW operation. The hold time increases with clockwise rotation.

(4) MIC GAIN/CARRIER

The MIC GAIN control varies the audio level of the microphone amplifier. The control has sufficient range to permit the use of any high-level crystal microphone or low level dynamic microphone. The outer control is used to insert carrier for AM operation.

(5) MODE

This switch is used to select the mode of operation. In OFF position, the line voltage to transceiver is completely off. Sideband is selected by removing the blocking bias from the appropriate oscillator. In the TUNE and CW positions, the USB oscillator is used and the audio signal to the balanced modulator and ALC voltage are shorted to ground, and carrier is supplied to the grid of a balanced mixer, V2 12AT7.

For AM operation, VR6, carrier potentiometer is placed in the circuit to adjust the carrier level. FSK circuitry is not wired in original equipment. The necessary information for FSK operation will be furnished through your dealer.

(6) IC-PO-ALC

The meter is selected to measure the total cathode current at IC position, relative power output at PO position, and ALC level at ALC position, and ALC level at ALC position.

(7) VFO

The VFO tuning consists of two dials. The main dial has two calibrated scales which are coloured red and black to match the colour of the band indicated on the BAND switch. The scales are 25kHz per division. The sub-dial on the tuning knob is divided in 100 divisions and 1 division is approximately equal to 1 MHz.

(8) GRID

The control is used to tune the plate circuit of the VFO mixer and driver stages.

(9) BAND

This control is used to select the amateur band upon which operation is desired, the 10 meter band is covered in 4 sections.

BAND	FREQUENCY RANGE	DIAL COLOUR
80 meters	from 3500 to 4100 kHz	red
40 "	6900 to 7500	black
20 "	13900 to 14500	black
15 "	20900 to 21500	black
10A "	27900 to 28500	black
10B "	28500 to 29100	red
10C "	28900 to 29500	black
10D "	29500 to 30100	red

(10) CHECK

The switch can be used to use the transmitter VFO to listen to any other frequency than operating frequency in the bands while the transmitter is used in transceive operation.

(11) SPOT

By pressing this switch, the blocking bias except to the final PA tubes is removed and a weak signal is transmitted to spot the frequency on the station receiver.

(12) TRANSCEIVE

This switch is used for the transceive operation in conjunction with our FR-receiver.

(13) PLATE

This control is used to tune the output circuit of the final linear amplifier, approximate tuning area for the bands is shown on the panel.

(14) LOADING

This control is used to match the output impedance of the pi network to feeder impedance.

(1) INITIAL CHECK

Prior to connecting to power outlet, carefully examine for any visible damage, check that all tubes and crystals are properly seated in their sockets, and check tuning controls and switches for complete freedom of action. Connect a dummy load to the coaxial cable connector.

Set the MODE switch to OFF position. Make sure that supply voltage is the same as the voltage marked on the rear apron of the chassis before connecting to power outlet. Set the controls as follows:

OPER: release position.
DELAY: fully counterclockwise.
VOX GAIN: OFF.
MIC GAIN: fully counterclockwise.
PO/IC/ALC: IC.
MAIN TUNING DIAL: 250kHz(center of the scale).
TRANSCIVE: fully left side position.
GRID: 5.
BAND: 20 meter.
PLATE: 20 meter portion.
LOADING: 0.

Connect AC cable to the power outlet. Set the MODE switch to USB, and wait for warmup. Push the OPER switch. Then the meter will indicate PA cathode current. It should be approximately 50 ma. If the cathode current is other than 50 ma, adjust BIAS potentiometer under top cover. Turn meter switch to the ALC position, and adjust ALC potentiometer under the top cover until meter reading shows exactly full scale. Set the MODE switch to TUNE position, and CARRIER control to position 5. Tune the PLATE tuning for dip quickly. This procedure should be done quickly to protect the PA tubes, and release the OPER switch. Set the MODE switch to USB, press OPER switch and VOX GAIN to 5 position speaking normally into the microphone, adjust RELAY control under top cover to activate the relay with speech.

(2) ACCESSORY SOCKET CONNECTION

Connections from the socket to the station receiver and any other additional equipment which may be used are shown in figures and should be made as follows.

pin	1	+150V
pin	2	FSK input.
pin	3	to the station receiver voice coil or 600 ohms output.
pin	4	FR receiver Mute terminal.
pin	5	ground
pin	6	relay terminal of FL linear amplifier.
pin	7	relay terminal.
pin	8	relay terminal.
pin	9	ground.

See figure illustrated in the following page.

(3) GROUND

The chassis ground connection that is provided on the rear apron of the transmitter should be connected to an actual earth ground by a heavy lead. It is not recommended that gas pipes or electrical conduit pipes be used. This ground lead should be as short as possible.

(4) ANTENNA

The pi network output impedance is designed to match a 50 to 120 ohm feeder. Most commercial antennas and feeders are designed to operate between 50 and 75 ohms. If the impedance is far from this value, the use of an antenna matching device is recommended.

(5) RF OUTPUT

The RF driving voltage is furnished to operate this unit for VHF exciter in conjunction with our FTV650 transvertor.

(6) EXT. OSC

For transceive operation with our FR receiver, connect between this terminal and VFO OUT terminal of the receiver with coaxial cable.

(7) POWER OUT

All necessary power requirement for our transvertor is supplied from this socket. When transvertor is not used, keep the plug in the socket otherwise the heater supply for final tubes, 6JS6 is disconnected.

Connections from the socket to the transvertor are as follows.

pin 1	no connection	pin 2	AC6.3V
pin 3	(+) 150V regulated	pin 4	(+) 300V
pin 5	(+) 600V	pin 6	(-) 100V
pin 7	ALC input	pin 8	ground
pin 9	relay	pin 10	no connection
pin 11	no connection		

Pin 1 and pin 2 is connected directly inside of the plug.

For Service Manuals Contact
MAURITRON TECHNICAL SERVICES
8 Cherry Tree Rd, Chinnor
Oxon OX9 4QY
Tel: 01844-351694 Fax: 01844-352554
Email: enquiries@mauritron.co.uk

OPERATION

It will be assumed all connections are in place as illustrated in following page.

(1) CW OPERATION

Set the controls as follows:

OPER	release position.
BAND	desired band.
MIC GAIN	fully counterclockwise
MODE	CW

VOX GAIN	OFF
DELAY	fully counterclockwise
VFO	desired frequency
LOADING	9 o'clock position
PLATE	desired band area indicated

Turn on the power and wait for the set to warm up. Set the MODE switch to TUNE position. Tune the station receiver to the frequency selected. Pressing the SPOT switch down, tune the VFO to zero beat with receiving frequency. If the spotting signal is too weak to zero beat, tune the grid and plate tuning for the loudest beat. Push the operation switch down. Tune the GRID for maximum plate current and PLATE for dip. Increase the LOADING for maximum power output. Meter reading shows approximately 300 MA at IC position. Release OPER switch and set the MODE switch to CW position. These tuning procedures must be done quickly. The transmitter is now fully tuned for manual CW operation. For break-in operation, connect the key as illustrated. Advance the VOX GAIN control until the relay is closed by keying. Adjust the

VOX DELAY control for the desired drop-out delay; delay time increases with clockwise rotation. Control under the top cover should be adjusted to activate the VOX relay with VOX keying in mid-position when speaking into microphone normally.

VOX DELAY
RELAY co
GAIN setti

OPERATION

(2) AM C

MODE switch to the AM position. Tune up exactly as is described in the CW mode. Adjust plate current to 150 ma with the CARRIER control under the top cover. Advance the CARRIER control till the plate current kicks up to 160 ma speaking into the microphone normally. For PTT, place the VOX GAIN to PTT position. For VOX operation advance the VOX GAIN until the relay activates the transmitter instantly when speaking into the microphone. Adjust the receiver gain control to the desired listening level. Advance the ANTITRIP control under the top cover clockwise until received signals do not actuate the VOX relay. Use no more than is necessary. For Push-to-talk operation the antitrip control may be turned off. The mode of transmitting is the carrier and upper sideband system.

Set the
Adjust the
MIC GAIN
In the case
GAIN until
the station
under the t
antitrip gain
This metho

OPERATION

(3) SSB C

Operate exactly as is described above and set the MODE switch to USB or LSB position. Adjust the receiver gain until meter shows about 150 ma at average speaking levels. Operate as described in AM operation PTT or VOX modes. The VFO scale on the knob is adjustable. Move the VFO knob holding the knob firmly for correct calibration. Check meter reading is within green scale to prevent overdrive at meter switch ALC position.

Tune u
Increase au
cribed in A
the scale by
coloured sca

RECEIVE OPERATION WITH FRdx400/500 RECEIVER:

(4) TRAN

Connect the cables as shown in the illustration of following page. Set the BAND SELECT switch on the transmitter to TRANSCEIVE position. Set the BAND SELECT switch on the receiver to the desired band and both MODE switches to the same position. Tune the receiver as in normal operation. Both transmitter and receiver frequency is controlled by the VFO. Due to the frequency tolerance of the HF heterodyne crystals, it may be necessary to adjust the CLARIFIER control of the receiver to zero beat transmitting and receiving

Connect
Set the
switches to
and transmi
the receiver
necessary to

frequencies. To do this it is best to use the MONITOR control of the receiver. Monitor the transmitted signal, and adjust the CLARIFIER control until the natural voice is heard.

If the transmitted frequency is changed by any great amount, be sure to redip the PA plate current and check the loading. It is possible to listen on the receiver at the operating frequency.

with the transmitter VFO by pressing down the CHECK control knob. Pressing this control down, the transmitter VFO voltage is introduced into the circuit to overlap the signals selected by the transmitter VFO.

DO NOT ATTEMPT OPERATION IN TRANSCEIVE SERVICE WITH ANY OTHER RECEIVER

F. dummy load.

(3) VOLTAGE MEASUREMENTS

Set the operation switch to release position, and allow the transmitter to warm up. Check the voltages of the tube at the tube socket by VTVM. The nominal values are given on the chart. 600 volts DC is only used for the final plate supply and 300 volts for the other supplies. A regulated supply is set at 150 volts by a potentiometer which is located under the top cover and marked VOLT REG.

(4) 455KHz CARRIER OSCILLATOR AND BM CIRCUIT

Tune the transmitter up on 3.8MHz (80 meter band) in TUNE mode into dummy load. Switch to upper sideband (USB on MODE switch). Connect a VTVM RF probe to the center of the balance potentiometer. Adjust the slug of L2 for maximum VTVM reading and turn half rotation to clock-wise direction. Disconnect the VTVM. Adjust the carrier null potentiometer and the trimmer capacitor located close to the mechanical filter assembly for minimum power output with the VTVM RF probe connected to antenna terminal. If VTVM is not available, a station receiver may be used for carrier balance indication. Release OPER switch. Connect VTVM RF probe to pin 5 of V3 and an audio oscillator to the MIC jack and tune it to 1500 Hz, and adjust two pot cores in the mechanical filter assembly for maximum VTVM reading.

(5) SIDEBAND OSCILLATOR AND 9MHz IF AMPLIFIER

To adjust sideband oscillator frequency, FR receiver should be connected in transceive operation. Set the receiver clarifier at center, and monitor the transmitted signal in USB mode. Adjust TC1 for natural listening to the audio quality. Set the MODE switch to LBS, both transmitter and receiver, and adjust TC6 for natural listening audio quality. Connect VTVM RF probe to pin 7 of 6AW8, in TUNE mode, adjust slugs on L1 and L2 for maximum VTVM reading.

(6) HETERODYNE MIXER AND OSCILLATOR

Set the band switch to 10D and operation switch to SPOT. Connect a signal generator to pin 7 of 6AW8A and a VTVM with the RF probe to pin 1 of V7, 6CB6. Remove VFO injection by the transceive switch. Tune the signal generator to 35.0MHz exactly and adjust the plate coil of the 6AW8 tube marked 10D for maximum output reading on the VTVM. Repeat this procedure with the band switched to 10C, 10B, 10A, 15 20 and 40 meters. The signal generator settings are 34.4MHz for 10C, 34.0MHz for 10B, 33.4MHz for 10A, 26.4MHz for 15, 19.4MHz for 20 and 12.4MHz for 40 meter. Set the BAND switch to 15 meter band. Tune the signal generator to 17.4MHz, and adjust L11 for minimum VTVM reading. Tune signal generator to 25MHz and adjust L5 for minimum VTVM reading. Set the BAND switch to 20 meters. Tune the signal generator to 9MHz and adjust the slugs of the trap coils L6 and L9 for minimum VTVM reading. Readjust the 20 meter plate coil for maximum VTVM reading on 19.4 MHz, because of interaction between two coils. Repeat this procedure for 40 meter with the setting of signal generator at 6.8MHz for L7 trap and 12.4MHz for the plate coil. Disconnect the signal generator and VTVM from the circuit and change TRANSCEIVE switch to VFO. Readjust all coils for maximum output except trap coils.

This is necessary to eliminate the errors due to VTVM's input capacitance and inaccurate setting of the signal generator. Connect VTVM to the output pin of L4 (9MHz output transformer). Set the MODE switch to LSB. Set the BAND switch to 10D. Adjust the slug of heterodyne

oscillator coil L37 for 0.5 volt RMS VTVM reading. Set the BAND switch to 10C and adjust TC13 for maximum VTVM reading. Adjust TC12 at 10B, TC11 at 10A, TC10 at 15, and TC at 20 meters. Set the BAND switch to 40 meters and adjust L36 to read VTVM 0.5 volt.

(7) VFO MIXER AND DRIVER PLATE COILS

Connect a 50 or 75 ohm dummy load to the antenna terminal. Tune the transmitter up on 28.8MHz on CW mode. Set the GRID control to center. Adjust the slugs of L13 and L19 marked 10 for maximum output. Repeat this procedure for all bands. This procedure must be done quickly to protect the final PA tubes.

(8) VFO CALIBRATION

If the dial error increases, the VFO corrector coil and trimmer should be readjusted. Proceed as follows; Set the BAND switch to 80 meter band. Tune the station receiver exactly to 3.5MHz. Set the VFO dial to 3.5MHz and adjust a slug on the bottom of the VFO box for zero beat. Tune the receiver to 4.1MHz exactly and set VFO to 4.1MHz. Adjust the trimmer capacitor TC-3 for zero beat, adjust until 3.5MHz and 4.1MHz are exactly at 6000 kHz frequency.

IMPORTANT: Do not use any oil on the VFO gear. Do not touch a red marked screw. This screw is the adjustable temperature compensator. (TC-7).

The temperature compensator is adjusted in following manner. Check the frequency drift at first. When VFO frequency drifts to higher direction, in another word, transmitting frequency drift toward lower direction, turn red marked screw counter clockwise for a loose. If it is clockwise, capacity decreases, therefore adjust TC3 to compensate this decrease.

(9) BIAS SETTING FOR FINAL TUBES

Tune the transmitter to SSB mode, set the VOX GAIN control to OFF and switch down. Adjust the bias control potentiometer under the top cover to (total cathode current) shows 50 milliampere.

(10) FINAL AMPLIFIER NEUTRALIZATION

The final amplifier may be neutralized as follows. Tune the transmitter to 21.3MHz (15 meter band) in CW MODE. Carefully tune the plate and observe the plate current dip and relative power output peak. A dip in plate current and a peak in power output occur at the same setting; the amplifier is neutralized. If not, adjust the neutralizing capacitor, in small increments (1/4-1/2 turn) with an insulated screw driver from the opening on rear apron of the chassis until neutralization is accomplished.

(11) VFO TRAP COIL (L42) ALIGNMENT

Set the BAND switch to 40 meters, and tune the VFO dial to scale 0 (5.4MHz). Connect a VTVM with the RF probe to pin 5 of one of V13, V14, 6JS6C's.

Set the MODE switch to LSB position, and turn the MIC GAIN control to fully counterclockwise. Press the OPER switch to as to obtain TRANSMITTING condition, and adjust the slug of the trap coil L42 for minimum VTVM reading,

For Service Manuals Contact
MAURITRON TECHNICAL SERVICES
8 Cherry Tree Rd, Chinnor
Oxon OX9 4QY
Tel: 01844-351694 Fax: 01844-352554
Email: enquiries@mauritron.co.uk

TROUBLE SHOOTING

Most cases of trouble can be traced to defective tubes. Substitution of new tubes will sometimes clear an obscure case. Intermittent fault in tubes can be discovered by lightly tapping the tube. Occasionally, tube socket terminals will become dirty or corroded causing an intermittent condition. Tables show typical voltage and resistance readings at each tube socket terminal except those of the VFO tube. These are the best aid in trouble shooting. Make all measurements under the conditions noted on the charts. The values listed are nominal, and vary slightly due to line voltage fluctuation and to normal tolerances in components.

g guide.

potentiometer. Defective bias circuit.

resonant at frequency. Defective and driver tubes.

adjusted carrier oscillator frequency modulator diodes. Mic gain

mechanical filter. 6BM8 regulator

high. Improper neutralization.

of VOX controls.

or neon tube NL-6S.

Following are typical cases of the trouble and a trouble shooting

- | | |
|---|--|
| PA idling current unstable: | Defective PA tubes. Defective bias supply. Defective voltage regulator circuit. |
| Inability to full load: | Grid improperly tuned. Antenna not properly terminated. Defective transmission line. Defective PA tubes. |
| Insufficient carrier or sideband suppression: | Carrier balance control improperly adjusted. Frequency incorrect. Defective balance control. Defective balance setting too high. |
| Distorted signal: | Defective ALC circuit. Defective mechanical filter. Defective microphone circuit defective. Mic gain setting too high. |
| Unstable VOX operation: | V10, 6U8 defective. Improper setting of VOX controls. |
| Frequency unstable: | Defective voltage regulator tube, 6BM8 |

For Service Manuals Contact
MAURITRON TECHNICAL SERVICES
8 Cherry Tree Rd, Chinnor
Oxon OX9 4QY
Tel: 01844-351694 Fax: 01844-352554
Email: enquiries@mauratron.co.uk

ACCESSORY SOCKET

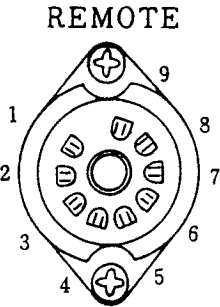

COIL ALLOCATIONS

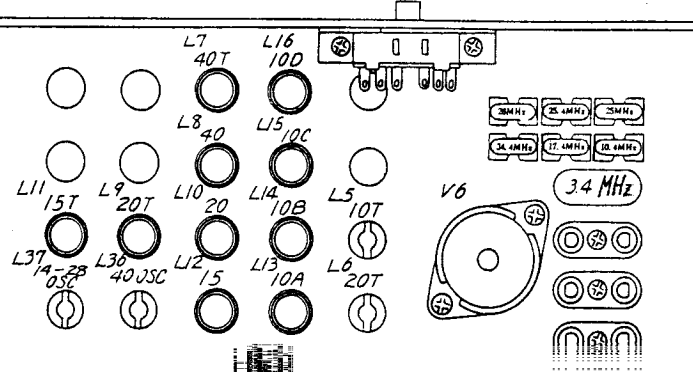

* T = TRAP

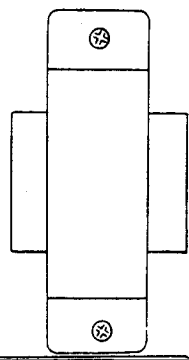
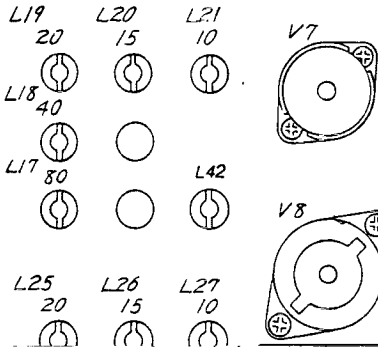

POWER OUT SOCKET

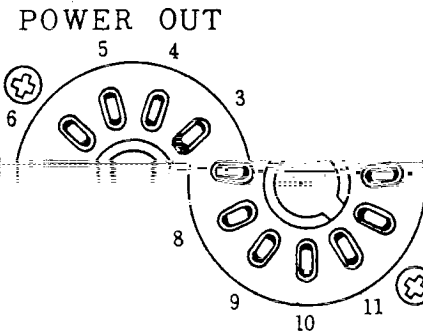

KEY AND MICROPHONE CONNECTIONS

Key connection

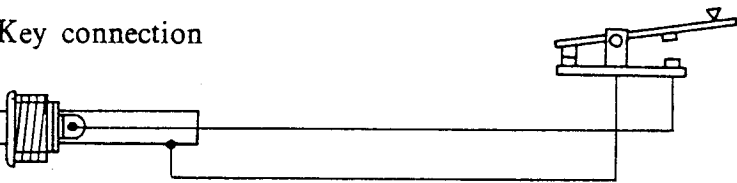

Connection for PTT operation

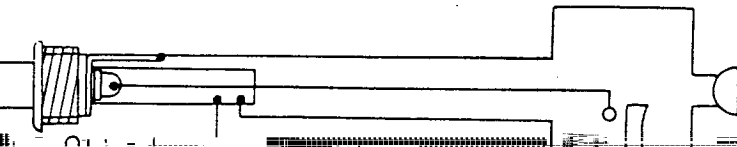

X operation

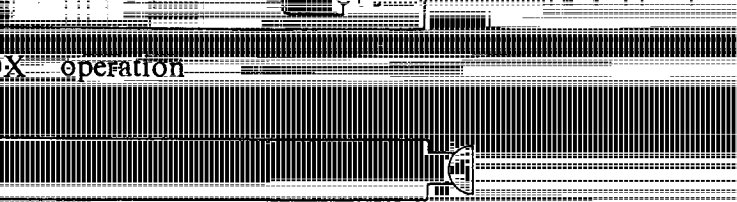

Connection for V0

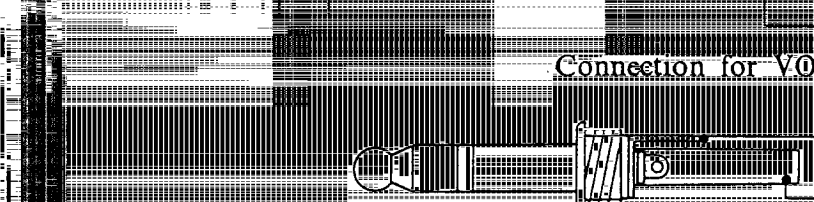

separately and connected together terminal.

Ground lead for microphone should be wired to the ground lead of PTT switch at plug terminal.

STATION INTERCONNECTIONS

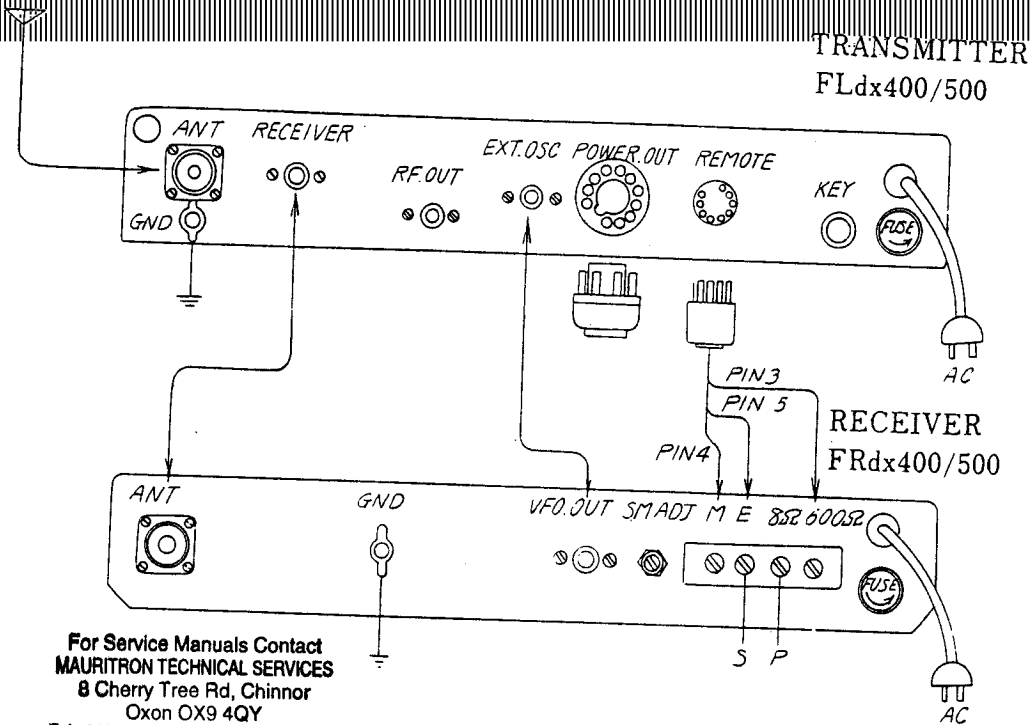

For Service Manuals Contact
MAURITRON TECHNICAL SERVICES
 8 Cherry Tree Rd, Chinnor
 Oxon OX9 4QY
 Tel: 01844-351694 Fax: 01844-352554
 Email: enquiries@mauritron.co.uk

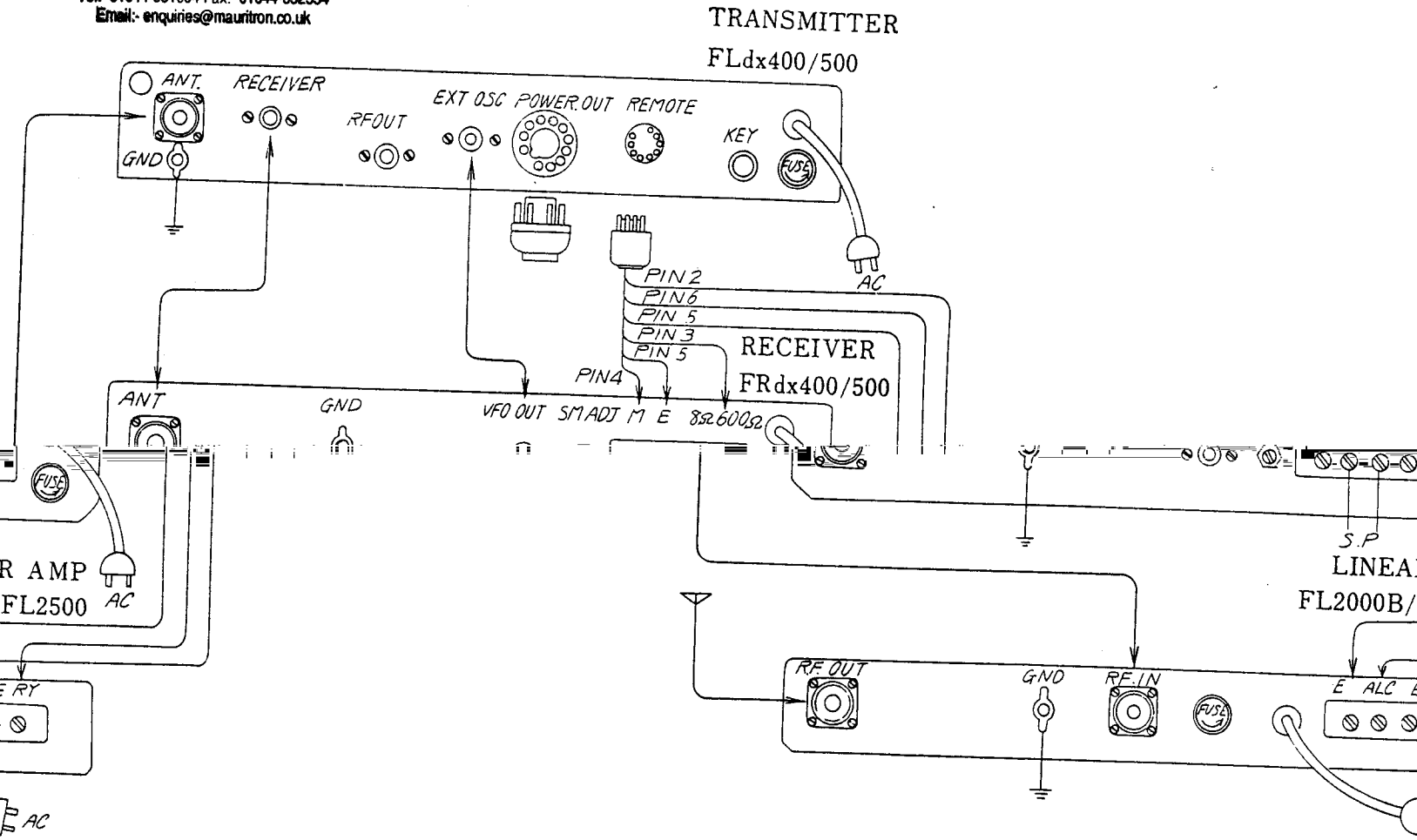

VOLTAGE - CHART

TUBE	PIN NUMBER												
	1	2	3	4	5	6	7	8	9	10	11	12	P
V1 6AN8	190V	0	3.8V	6.3V	0	40V	0.6V	2.4V	0				
V2 12AT7	145V	0	3.2V	0	0	145V	0	3.2V	6.3V				
V3 6BA6	0	3.5V	6.3V	0	270V		130V	3.6V					
V4 12AU7	120V	-70V	2.4V	0	0	120V	-70V	2.4V	6.3V				
V5 6U8	125V	-4.5V	50V	6.3V	0	120V	0	1.5V	0V				
V6 6AW8	0	-2V	140V	6.3V	0	0-2.6V	-10V-0	195V	310V				
V7 6CB6	-14V/0	0/1.8V	6.3V	0	310V		140V	0/1.8V					
V8 12BY7	9/4V	-14V/0	0	6.3V	6.3V	0	310V	280V	0				
V9 6BM8	45V	140V	120V	6.3V	0	310V	310V	50V	120V				
V10 6U8	0-170V	0	25V	6.3V	0	25V	0.8V	2.4V	-0.4V				
V12 VR150	150V	0	0	0	150	0	0						
V13 V14 6JS6A	6.3V	0	150V	0	-55V/ -45V		0	0	-55/ -45V	0	150V	0	

•印 AC VOLTAGE

RESISTANCE - CHART

TUBE	PIN NUMBER												
	1	2	3	4	5	6	7	8	9	10	11	12	P
V1 6AN8	50K	47K	500K	0	0	500	1K	220Ω	0-500				
V2 12AT7	30K	10K	1K	0	0	30K	100K	1K	0				
V3 6BA6	70K	330Ω	0	0	35K	40K	330						
V4 12AU7	50K	270K	470Ω	0	0	50K	270K	470Ω	0				
V5 6U8	60K	470K	280K	0	0	40K	0	0	0-500K				
V6 6AW8	0	47K	40K	0	0	330Ω	50K	60K	30K				
V7 6CB6	60K	330Ω	0	0	30K	60K	330Ω						
V8 12BY7	100Ω	50K	0	0	0	0	30K	30K	0				
V9 6BM8	15K	50K	1M	0	0	30K	30K	∞	1M				
V10 6U8	60K	0-500K	1M	0	0	500K	1K	150Ω	1M-3M				
V12 VR150	35K	0	8	0	35K								
V13 V14 6JS6A	0	0	50K	0	25K	25K	0	∞	25K	0	50K	0	

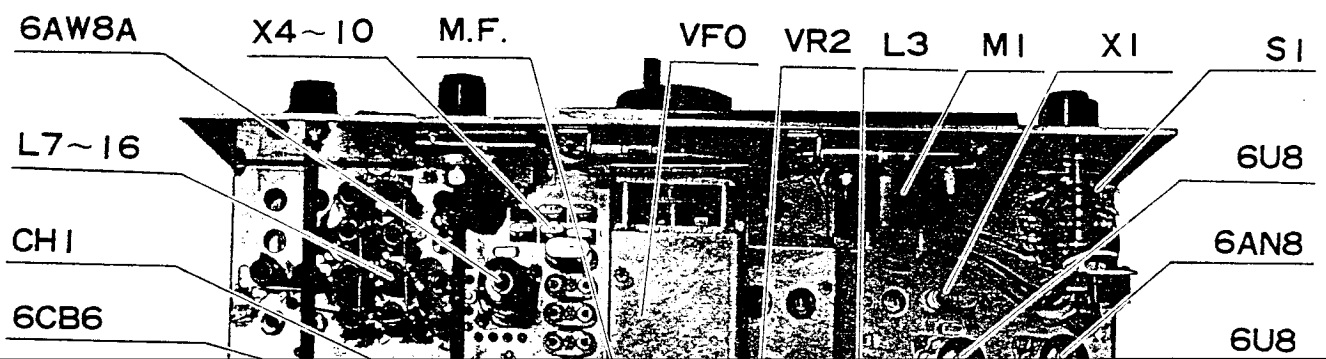
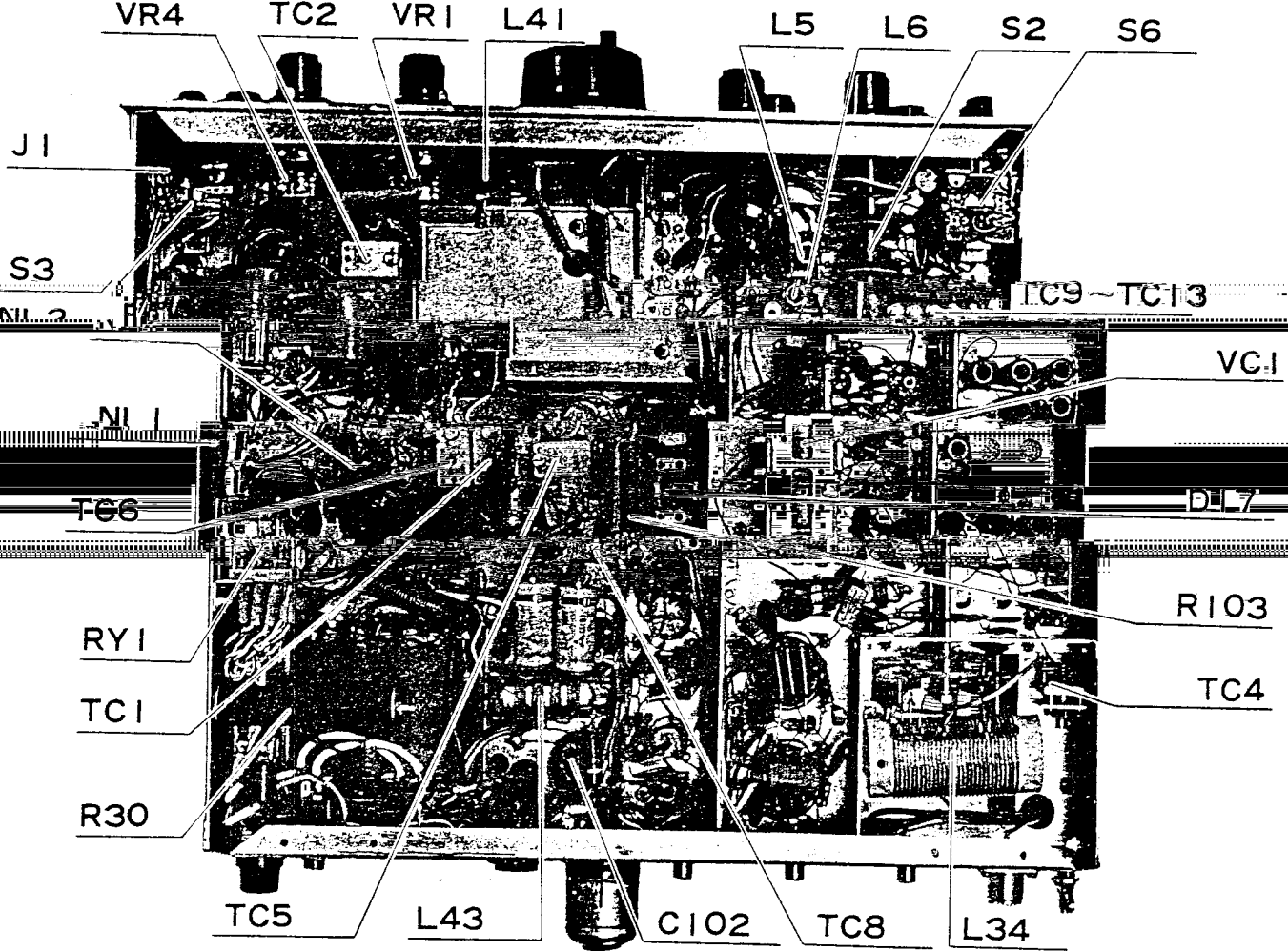

(MICA)-C				VR-(POTENTIOMETER)		
75	1 KWV	50P	±10%	1 (CARRIER) (MIC GAIN)	2 KB	500K A
84	3 KWV	1000P		2 (BALANCE)	200Ω B	
(FM-MICA)-C				3 (ALC ADJ)	5 KB	
5, 9, 48, 144, 78	500WV	250P	±10%	4 (DELAY)(VOX GAIN)	3 MB.	500K A
8, 14, 15, 16, 31, 12	500WV	100P	±10%	5 (RELAY)	3 KB	
54, 66, 98, 148, 151				6 (VOLT REG)	50K B	
156				7 (ANTITRIP)	500K A	
11, 76	500WV	400P	±10%	8 (BIAS)	20K B	
18, 41	500WV	470P	±10%	9 (FSK) OPTION	500K A	
145	500WV	500P	±10%			
17, 49, 63, 64, 73	500WV	70P	±10%	T-(TRANS FORMER)		
19, 20, 26, 27, 40	500WV	50P	±10%	1	POWER TRANS	
47, 50, 51, 53, 62				CH-(CHOKE TRANS)		
72				1	2.5 H	150mA

				RY-(RELAY)		
28, 74, 150	500WV	30P	±10%	1 (VOX)	SRE-5D11 DC100V	
38	500WV	2P	±10%	2 (A-N)	AR-42 DC100V	
42	500WV	2P	±10%	M(METER)		
52, 152, 153, 143	500WV	20P	±10%	1	MRA-45	
55, 61, 71, 85	500WV	150P	±10%			
65	500WV	40P	±10%	NL-(NEON LAMP)		
79	500WV	180P	±10%	1	NL-6S	
86, 124	500WV	10P	±10%	2	NE-68	
106	500WV	1000P	±10%	PL-(PILOT LAMP)		
132, 140	500WV	5P	±10%	1, 2	6.3V - 8V (SWAN)	
133	500WV	300P	±10%	PLH-(PILOT LAMP HOLDER)		
139, 146	500WV	200P	±10%	1, 2	NO-3512	
142	500WV	120P	±10%	NLH-(NEON LAMP HOLDER)		
				1	S-E3004 (SWAN)	
(CERAMIC) DISC TYPE				F-(FUSE)		
4, 7, 10, 13, 21	500WV	0.01μ	+100% -0	1	100V - 117V (5A) 200V - 234V (3A)	
22, 23, 25, 30				FH-(FUSE HOLDER)		
34, 35, 43, 44, 45				1	S-N1001	
46, 57, 58, 59, 60				(PLATE CAP)		
67, 68, 69, 70, 77				1, 2	FOR 6JS6A	
80, 82, 96, 101, 107				X-(CRYSTAL)		
108, 109, 110, 111, 112				1 (CARRIER)	HC/6U	453.5 kHz
113, 114, 115, 116, 117				2 (USB)	"	8543.5 kHz
118, 119, 121, 122, 125				3 (LSB)	"	9453.5 kHz
126, 128, 129, 130, 131						
134, 141, 147, 149, 155						

AL 150VAC ±100%				4P(40)		
104, 105, 127	1.4KVDC	0.01μ	-0	5 (20)	HC/25U	10.4 "
135, 136, 137, 138	AL 150VAC		+100%	6 (15)	"	17.4 "
	1.4KVDC	4700P	-0	7 (10A)	"	24.4 "
TC-(TRIMMER CAPACITOR)				8 (10B)	"	25.0 "
1, 6, 2	#412	50P	MAX	9 (10C)	"	25.4 "
5	#412	100P	MAX	10 (10D)	"	26.0 "
8	1ZW32	10P	MAX			
9-13	1ZW32	20P	MAX	(RUBBER GROMMET)		
401 (VFO)	TSN150C	30P	MAX	NG-79-A		2
402 (")	TSN150C	10P	MAX	" E		2
4 (NEUT)	TSN170C	10P	MAX	" G		3
VC-(VARIABLE COPACITOR)				KG-146		1
1 (GRID)	340P × 2	18P × 2		(KNOB)		
2 (PLATE)	300P			(VOX)(MIC)(GRID)(PLATE)(LOADING) FT-25		
3 (LOADING)	430P × 2					

FOR 25kHz			(PRINTED BOARD)		(MAN DIAL)	
11			1 (MF1)	PB-1027		
3			2 (VFO)	PB-1056		
1			3 (TRIMMER)	PB-1025		
3			(MECHANICAL FILTER)		(TERMINAL)	
3			MF-1	MF455 10A Z 28	1 L 4 P	
			D-(DIODE)		1 L 2 P	
			1-4, 7	1 S 1007	1 L 1 P	
			5, 6, 12-16	SH-1	1 L 4 P (S)	
			8-11	SD-1 C	1 P	
			17	1 S 334		
			18 (FSK) OPTION	1 S 568		
			S-(SWITCH)			
			1, 8 (MODE) (POWER SW)	4-7-7 (SW × 1)		
			2 (BAND)	8-10-11		
			3, 6 (OPER) (SPOT)	1S(L)22		
			4 (CHECK)	1S(A)22		
			5, 7 (TRANSCIVEIVE) (METER)	SSH-23		

For Service Manuals Contact
MAURITRON TECHNICAL SERVICES
 8 Cherry Tree Rd, Chinnor
 Oxon OX9 4QY
 Tel: 01844 351694 Fax: 01844 351695
 Email: enquiries@mauritron.co.uk

V1 6AN8
MIC AMP

V2 12AT7
BAL MIX

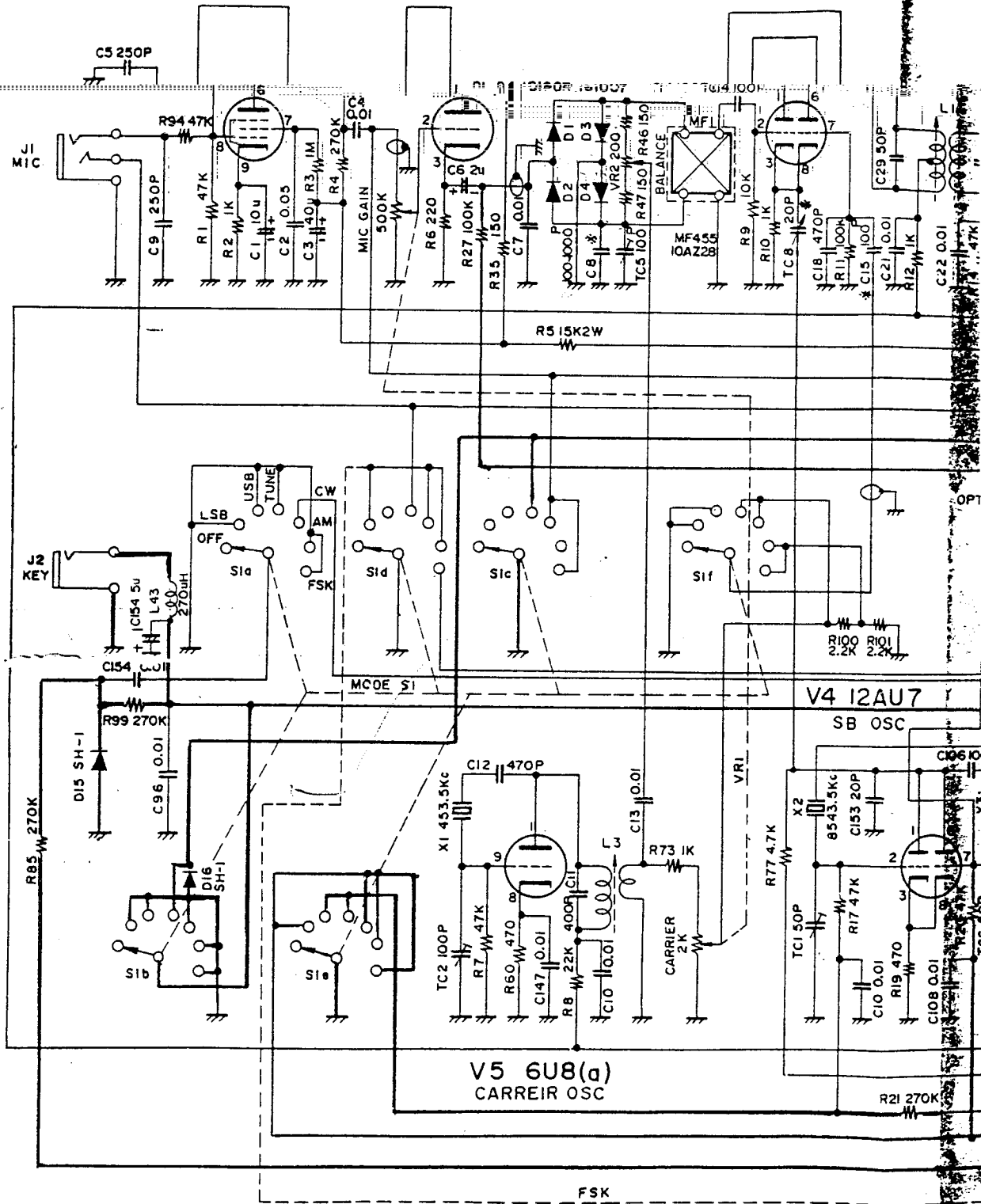

For Service Manuals Contact
MAURITRON TECHNICAL SERVICES
 8 Cherry Tree Rd, Chinnor
 Oxon OX9 4QY
 Tel: 01844-351694 Fax: 01844-352554
 Email: enquiries@maurtron.co.uk

V1 6BA6
P AMP

V6 6AW8A(d)
HEI MIX

V2 12A1
BAL MIX

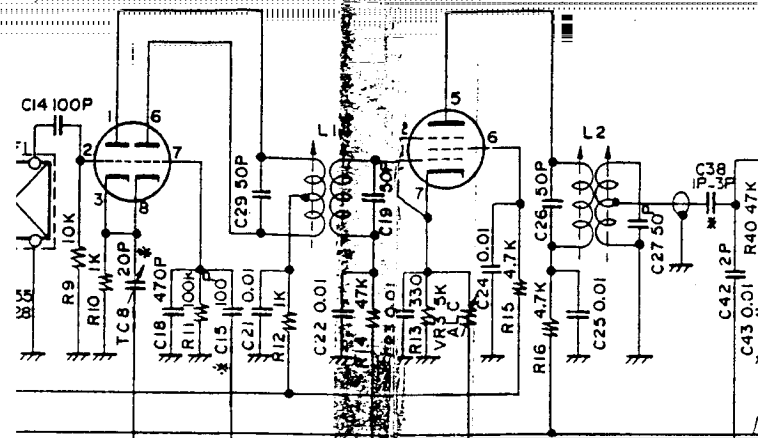
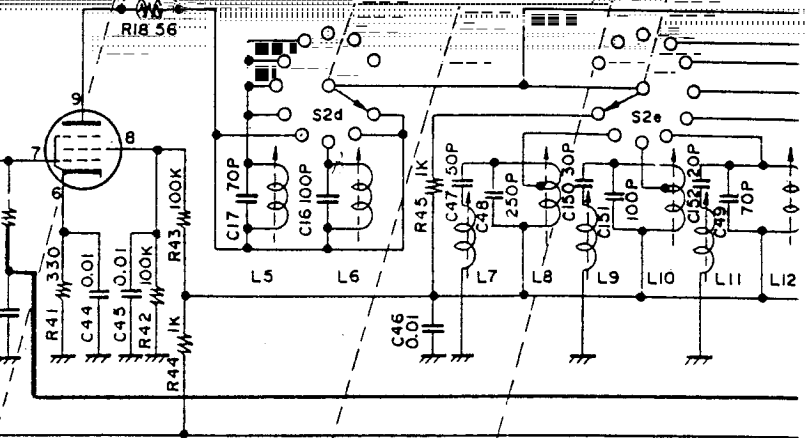

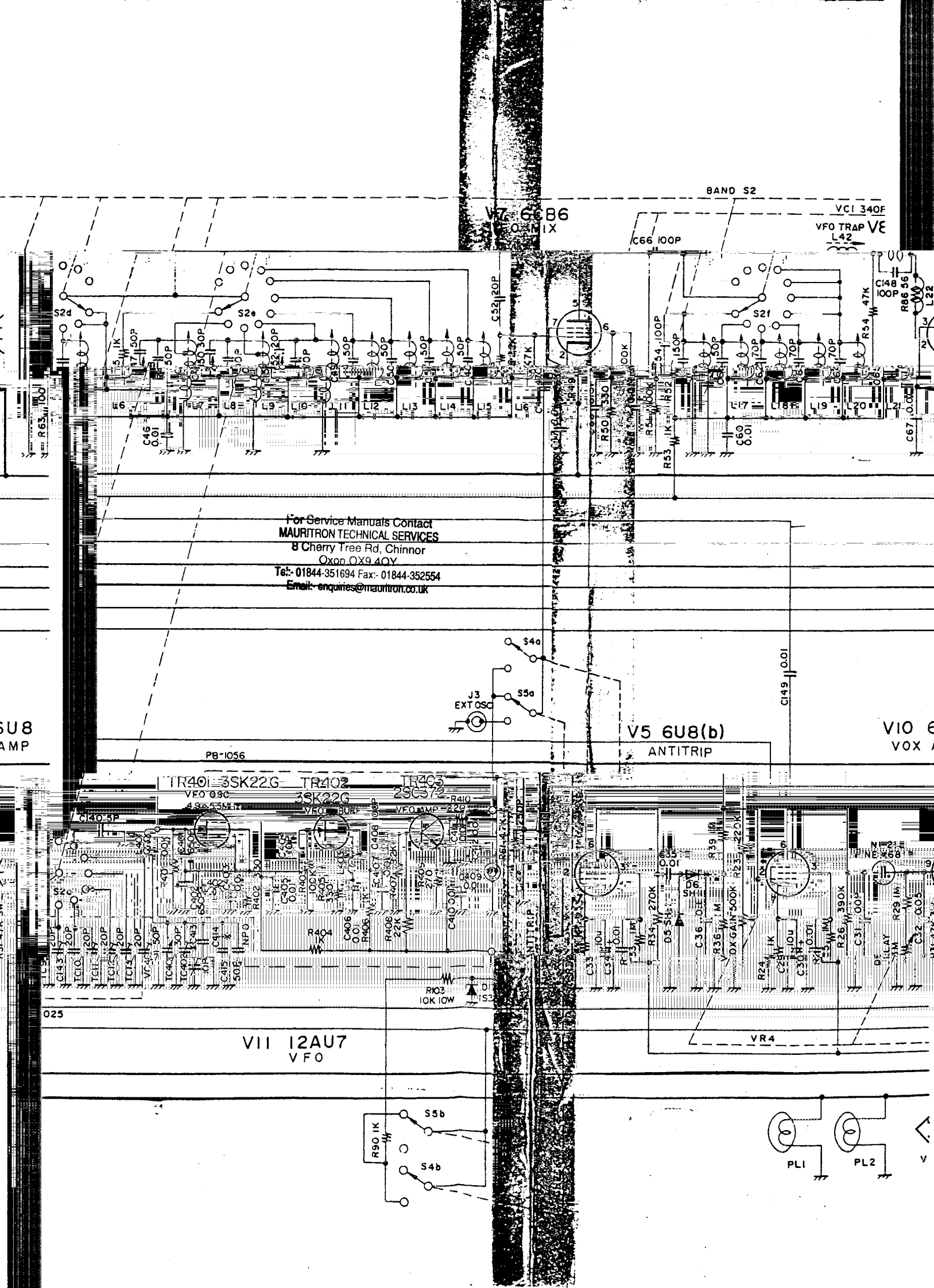

For Service Manuals Contact
MAURITRON TECHNICAL SERVICES
8 Cherry Tree Rd, Chinnor
Oxon OX9 4QY
Tel: 01844-351694 Fax: 01844-352554
Email: enquiries@mauritron.co.uk

SU8
AMP

BAND S2

V7 6C86
VFO

VCI 340F
VFO TRAP VE
L42

C66 100P

C48 46
100P

R86 46
100P

L22

C67 0.001

PB-1056

V5 6U8(b)
ANTITRIP

VIO 6
VOX

TR401 3SK22G TR402 3SK22G TR403 2SC372-R410
VFO OSC 480.03MHz VFO BURP VFO AMP 220

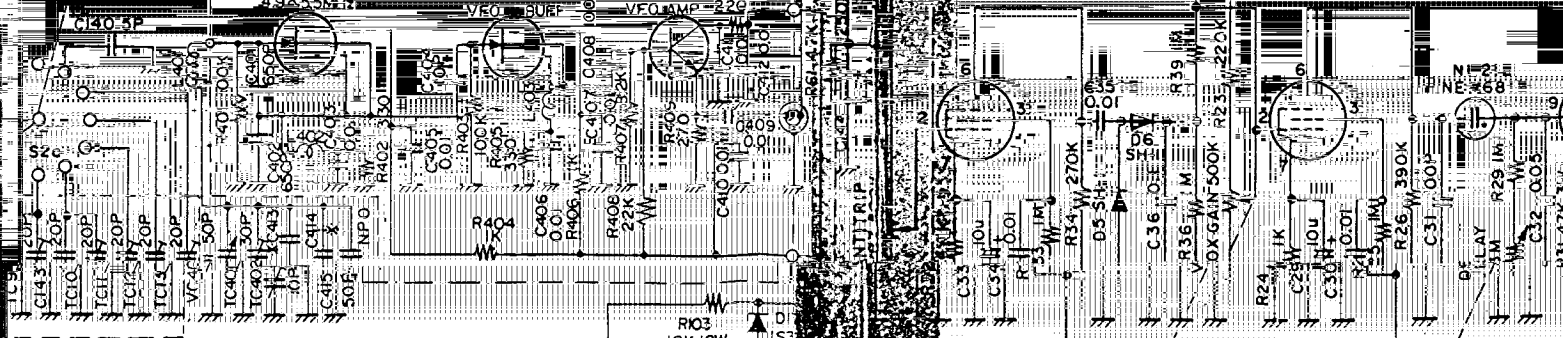

025

VII 12AU7
VFO

VR4

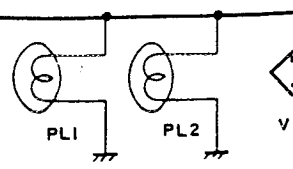
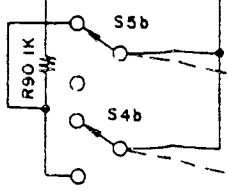

For Service Manuals Contact
MAURITRON TECHNICAL SERVICES
 8 Cherry Tree Rd, Chinnor
 Oxon, OX9 4QY
 Tel: 01844-351694 Fax: 01844-352554
 Email: enquiries@mauritron.co.uk

