

# INSTALLATION

INSTALLATION INSTRUCTIONS FOR THE 1000 SERIES

# TABLE OF CONTENTS

	Page
SPECIFICATIONS . . . . .	2
INTRODUCTION . . . . .	3
CIRCUIT THEORY . . . . .	4
SINGLE SIDEBAND TRANSMISSION . . . . .	6
AM Generation . . . . .	6
Sideband Generation . . . . .	6
Single-Sideband-Suppressed-Carrier Transmission . . . . .	7
INSTALLATION . . . . .	10
Power Supply . . . . .	10
Antenna . . . . .	10
Microphone . . . . .	10
Cable Connections . . . . .	10
Relay Control . . . . .	10
Carrier Synchronization . . . . .	10
OPERATION . . . . .	12
Control Functions . . . . .	12
Pre-Operating Adjustments . . . . .	13
Transmitter Operation . . . . .	13
Transmitter Tuning . . . . .	14
Single Sideband Voice Transmission . . . . .	15
AM Transmissions (Single Sideband with Carrier) . . . . .	15
CW Operation (Manual) . . . . .	16
CW Operation (Semi-Break-In) . . . . .	16
CW Operation (Full Break-In) . . . . .	16
Frequency Shift Keying (FSK) . . . . .	16
Slow Scan Television (SSTV) . . . . .	16
Sidetone Oscillator . . . . .	17
Off-Set CW Transmit Frequency . . . . .	17
Frequency Calibration . . . . .	17
Tuning Higher or Lower Frequency Segments . . . . .	17
ALIGNMENT AND TROUBLESHOOTING . . . . .	19
Transmitter Alignment . . . . .	19
VFO Amplifier Plate Circuit . . . . .	19
Mixer and Driver Plate Circuit . . . . .	19
Carrier Frequency Adjustment . . . . .	20
P.A. Neutralization . . . . .	20
VFO Alignment . . . . .	21
Carrier Balance . . . . .	21
PARTS LIST . . . . .	27

## LIST OF ILLUSTRATIONS

	Page
Figure 1. Block Diagram of 600-T . . . . .	5
Figure 2. Interconnection Diagram 600-R to 600-T . . . . .	11
Figure 3. Rear View of 600-T . . . . .	22
Figure 4. Top View of 600-T . . . . .	23
Figure 5. Bottom View of 600-T . . . . .	24



## PLUG IN VOX:

Optional accessory. Also provides Semi-Break-in CW.

## FRONT PANEL CONTROLS:

MIC. JACK . . . SIDEBAND SELECTOR: *CW-NORMAL-OPP* . . . MIC. GAIN . . . CAR. BAL . . . GRID TUNING . . . CW KEY JACK . . . POWER SWITCH . . . FUNCTION SWITCH: *SPOT-VOX-PTT-TRANS-TUNE* . . . DIAL SET . . . MAIN TUNING . . . P.A. LOAD . . . P.A. PLATE . . . BAND SWITCH . . . HIGH/LOW POWER.

## REAR PANEL CONTROLS AND CONNECTIONS:

EXT OSC . . . TO 600-R . . . VFO CONTROL: *J2-J3* . . . GND TERMINAL . . . CW BREAK-IN: *SEMI-FULL* . . . FUSE 10A . . . POWER CORD . . . RELAY CONTROL JACK . . . CAR. OSC. TEST . . . J1 RECEIVER . . . ANTENNA CONNECTION 50-75 OHM . . . AUX P.A. LOADING: *80M-40M* . . . VOX CONNECTOR.

## SIDE AND BOTTOM CONTROLS:

P.A. BIAS: *HIGH POWER (SIDE) - LOW POWER (BOTTOM)* . . . CAR. FREQ. ADJUST: *NORMAL-OPPOSITE*.

## VACUUM TUBE COMPLEMENT:

V1	12BZ6	VFO Amplifier
V2	12BE6	Mixer
V3	6GK6	Driver
V4	6KD6	Power Amplifier
V5	6KD6	Power Amplifier
V6	12BA6	I.F. Amplifier
V7	6JH8	Balanced Modulator
V8	12AX7	Mic. Amplifier/Trans. Audio.
V9	6FG6	Tuning Eye

## DIODE AND TRANSISTOR COMPLEMENT:

D401	1N4005	ALC Diode
D402	1N4005	ALC Diode
D901	1N34A	Tuning Eye Diode
D1201	Thru	
D1208	1N4005	Power Supply Diodes
D1209	1N4005	Bias Supply Diode
D1210	1N4005	Relay Supply
D1211	1N4005	CW Switching
D1212	ZENER	Voltage Regulator
Q1	2N706	VFO
Q2	2N706	Buffer
Q3	2N5322	Rec. Mute
Q4	2N706	Carrier Oscillator

## ACCESSORIES:

The following accessories are available for use with the Swan 600-T Transmitter:

- Model 508 External VFO
- Model 510X Crystal OSC.
- Model VX-2 VOX
- Mark II Linear Amplifier

## POWER REQUIREMENTS:

117 volts, 50-60 cycle. Current consumption: 2.2 amps in standby (PTT), 6.2 amps in TUNE, and 3.5 amps average with voice modulation.

## DIMENSIONS:

15 inches wide x 6½ inches high x 12 inches deep. Weight 32 pounds.

# INTRODUCTION

The Swan Model 600-T Transmitter is designed to be used in CW, AM, SSB, FSK, and SSTV modes over all portions of the 80, 40, 20, 15, and 10 meter amateur radio bands. Expanded frequency coverage is possible with the use of the optional accessory 510X Crystal Controlled Oscillator; Model 508 External VFO Oscillator, or Model 330 General Coverage Tuner. Basic circuitry of the single conversion design has been proven in many thousands of the popular Swan Transceivers. Mechanical, electrical, and thermal stability is exceptionally high. All oscillators are temperature

compensated and voltage regulated. Operation may be fixed or portable. Carrier suppression is typically greater than 60 db, and unwanted sideband suppression is down more than 50 db. Power input on all bands exceeds 600 watts, P.E.P., on single sideband; 500 watts DC on CW; 150 watts DC on AM; and 100 watts continuous on RTTY/SSTV. The 600-T includes automatic level control (ALC), grid block keying, CW sidetone monitor, and provisions for Full and Semi-Break-in CW keying.

## CIRCUIT THEORY

Refer to Figure 1, and the schematic diagram for the following discussion.

When the push-to-talk switch on the microphone is pressed, the transmitter is activated, and generates a single sideband, suppressed carrier signal in the following manner.

Audio from the microphone is coupled through C802 to the grid of the Mic. Amplifier V8B. The audio is amplified and coupled through C810, and the MIC. GAIN control R806, to the grid of the transmit A.F. Amplifier V8A. The audio is again amplified, and coupled through C704 to the deflection plate of the Balanced Modulator.

Carrier is generated at approximately 5500 KC in the transistorized carrier oscillator circuit Q3. The RF output of the carrier oscillator is injected into the control grid of the Balanced Modulator through C1006. This Balanced Modulator is a beam deflection tube, and operates similar to a cathode ray tube, in that the electron beam from the cathode is deflected to one output plate or the other by the charge appearing on the deflection plate. The carrier RF signal fed to the control grid of the Balanced Modulator appears on both plates of the output. The two plates are connected to T701 in push-pull, so that the carrier signal cancels itself out in T701. The deflection plate DC voltages are adjusted by the Carrier Balance control R712, so that the RF being fed to the output plates will cancel out, and the output from T701 will be zero. Audio signals from the transmit A.F. Amplifier V8A, are applied as a modulating voltage to one deflection plate, and the two sidebands resulting from the sum and difference frequencies of the audio and carrier frequency heterodyning appear in the output of T701. Carrier suppression is approximately 60 db.

The double sideband, suppressed carrier signal is then coupled from the secondary winding of T701 through C702, to the Crystal Lattice Filter. The Crystal Lattice Filter suppresses the Lower Sideband, and permits only the Upper Sideband to be fed to the grid of the I.F. Amplifier V6. With the Opposite Sideband crystal, the carrier frequency is generated at approximately 5503.3 KC, and this positions the double sideband signal on the other side of the filter response curve, attenuating the Upper Sideband by at least 50 db. The output of the I.F. Amplifier is coupled through T601 to the control grid of the Mixer V2.

Q1, the transistorized VFO Oscillator, operates in the common base configuration as a colpitts oscillator. Q2, the Buffer Amplifier, is used for isolation. The extremely good regulation achieved through using the Zener diode regulator DI212 across the bias supply voltage, also contributes to the stability. Bandswitching is accomplished by changing the tank circuit coil. The VFO exhibits extremely good

stability after the initial warm-up period. Drift from a cold start will be less than 1 kc for the first hour on 80, 40, and 20 meters, and less than 2 kc on 15 and 10 meters. After warm-up, drift will be negligible. The output of the VFO Oscillator is coupled through C1117 to the grid of the VFO Amplifier V1. Plate tuning is accomplished by L101 through L103 and their associated components. The signal is amplified and coupled through C104 to the injection grid of the Mixer V2.

In the Mixer, the VFO injection frequency is subtractively heterodyned with the I.F. signal on 80 and 40 meters, and the resultant output is the Lower Sideband R.F. operating frequency. On 20, 15, and 10 meters, the VFO injection frequency is additively heterodyned with the I.F. signal, and the resultant output is the Upper Sideband R.F. operating frequency. Plate tuning is accomplished by L201 through L205 and their associated components. The output of the Mixer is coupled through C204 to the grid of the Driver V3, where the signal is amplified and coupled through C303 to the grids of the Power Amplifiers V4 and V5. Grid drive for the Driver and Power Amplifiers is provided by the mechanically ganged Grid Tuning capacitors C209/C307. The Driver plate circuit is tuned by L302 through L306 and the associated components.

The Power Amplifiers are connected in parallel, and their output is coupled through the two parasitic suppressors, Z401/Z402; through the two parallel capacitors C411/C412; to the wide range Pi-network. The Pi-network consist of L404; the two section P.A. Tune capacitors C413A/C413B, and C414; the two section P.A. Load capacitors C417A/C417B, and C418, L405; and the Auxiliary Loading capacitors C415, C416. The output of the Pi-network is terminated at the coaxial antenna connector J7. Neutralization of the Power Amplifiers is accomplished by adjusting C410.

S4, the HIGH/LOW power switch, controls the screen voltage being applied to the Power Amplifier tubes. In the HIGH position, the screen voltage is routed around the divider resistors R410/R411, allowing the +215 volts to be applied to the screen grids of the power amplifier through the screen resistors R417/R416. In the LOW position, the +215 volts is divided down approximately 30% by R410/R411.

In addition to controlling the screen voltage of the Power Amplifier tubes, S4 also controls the P.A. BIAS being applied to the grids of the Power Amplifier Tubes. When the HIGH/LOW POWER switch is in the HIGH position, the HIGH POWER P.A. BIAS potentiometer R404 controls the bias applied to the grids of the P.A. The LOW POWER P.A. BIAS potentiometer R408 is switched in series with the HIGH POWER P.A. BIAS potentiometer when the HIGH/LOW power switch is placed in the LOW POWER position.

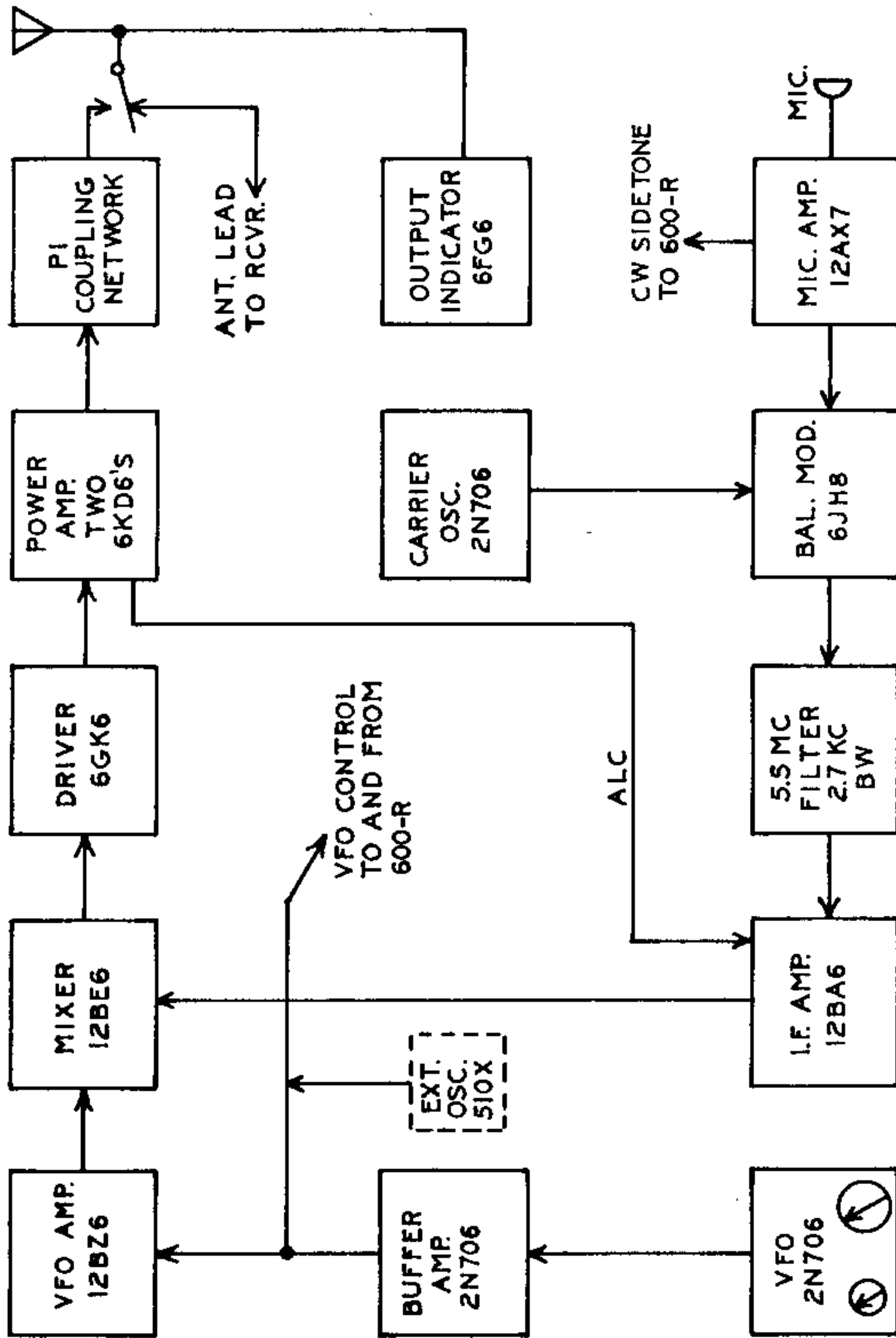

FIGURE 1. BLOCK DIAGRAM OF 600-T

The amplified automatic level control (ALC) circuit consists of D401, D402, C401, C402, R401, and R605. The negative voltage developed by this circuit is fed back to the grid of the I.F. Amplifier V6.

CW keying is accomplished by grounding the blocking bias applied to the grids of the Mixer, Driver, and Balanced Modulator stages. When the CW key is closed, bias is also removed from the grid of the Mic. Amplifier V8B, causing the Mic. Amplifier to oscillate at approximately 800 cycles. This 800 cycle sidetone is coupled through C810; through the MIC GAIN control R806; to the grid of the A.F. Amplifier V8A. The output of the A.F. Amplifier is fed through pin 11 of the "TO 600R" socket on the rear of the transmitter to the receiver for CW monitoring.

Receiver muting is accomplished by ungrounding the -35 volt bias line to V1, V2, and V3 in the 600-R receiver. When the CW BREAK-IN switch is in the FULL position,

the transistorized REC. MUTE stage, Q3, ungrounds the bias line. When the CW BREAK-IN switch is in the SEMI position, a contact on relay K1, ungrounds the bias line.

Power for the transmitter is supplied by the built-in power supply. Full-wave rectification is provided by the bridge circuit comprised of D1201 thru D1208, which supplies the positive 800, 275, and 215 volt plate and screen voltages. The filter network is comprised of C1204, C1205, and C1207, which are computer grade capacitors, and R1201, R1202, R1203, and R1204. The negative 110 volt bias is developed across D1209 from a separate winding of T1201. The negative 12 volt transistor voltage is developed across R1206, R1207, and is regulated by the Zener diode D1212. The 12.6 AC filament voltage is supplied by a separate winding of T1201, and in addition, the positive 12 volt DC relay control voltage is developed by D1210 from this same winding.

## SINGLE SIDEBAND TRANSMISSION

To permit a logical discussion of the techniques and circuits required to generate a single-sideband-suppressed-carrier signal in the Swan Model 600-T Transmitter, it is important to understand the generation of an AM (Double Sideband with Carrier) R.F. signal.

### AM GENERATION:

A conventional AM transmitter normally consists of a Master Oscillator, Buffer Amplifier, Doubler Amplifier, Tripler Amplifier, and a Final Amplifier. A low frequency R.F. carrier is generated in the Master Oscillator stage, and is doubled or tripled as required to arrive at the desired operating frequency. In order to voice modulate this R.F. carrier, a Speech Modulator was required. Since high level modulation was normally desired, plate modulation of the Final Amplifier was required. In order to modulate the Final Amplifier, the Speech Modulator had to be capable of delivering sine-wave audio power equal to 50% of the d.c. plate power input to the Final Amplifier. In other words, if the d.c. plate power input to the Final Amplifier stage is 100 watts, the sine-wave audio power output of the Speech Modulator must be 50 watts. When the sine-wave audio is mixed with the R.F. carrier frequency, sidebands are generated which are the sum of, and the difference between, the two heterodyned signals. A fully modulated AM signal has about two-thirds of its power in the carrier, and

only about one-third in the sidebands. Since the sidebands carry all of the audio intelligence, and the intelligence contained in one sideband is duplicated in the other sideband, AM is an inefficient means of transmission. There are other attendant drawbacks also. The bandwidth of the AM transmission is approximately 6 kc, while the actual demodulated audio is only approximately 3 kc.

### SIDEBAND GENERATION:

When a modulated audio frequency, such as one produced by a human voice, is heterodyned with an R.F. carrier frequency, sideband frequencies are generated which are the sum of, and the difference between, the two heterodyned frequencies. To many, these sideband frequencies are thought of as having only a single frequency with a very small bandwidth. In fact, however, these sidebands are separated from the R.F. carrier frequency by the sum and difference of the audio frequency. For example, a typical intelligible voice signal contains audio frequencies in the frequency range of 300 to 3000 cycles. If this modulating audio frequency is heterodyned with an R.F. carrier frequency of 5,500,000 cycles, the resultant sum frequencies cover the frequency range of 5,500,300 cycles to 5,503,000 cycles, and these are called the upper sideband. Likewise, the difference frequencies cover the frequency range of 5,499,700 cycles to 5,497,000 cycles, and are called the

lower sideband. From the above information, it is apparent that each of the sidebands occupy a bandwidth of approximately 2,700 cycles. Since the sideband frequencies carry all the audio intelligence that is impressed on the R.F. carrier frequency, and the intelligence contained in one of the sidebands is exactly duplicated in the other, only one sideband need be transmitted. The other sideband and carrier can be suppressed. It should be remembered that in the single-sideband-suppressed-carrier mode of transmission, the unwanted sideband and carrier are greatly suppressed, but not entirely eliminated. Thus, with a transmitted signal from a transmitter with 50 db sideband suppression, the other, or unwanted sideband, will be present, and will be transmitted, but its level will be 50 db below the wanted sideband. When this signal is received at a level of 20 db over S9, the unwanted sideband will be present at a level of approximately S5. The same is true of carrier suppression. With carrier suppression of 60 db, and a signal level of 20 db

over S9, carrier will be present at a level of approximately S3 to S4.

#### **SINGLE-SIDEBAND-SUPPRESSED-CARRIER TRANSMISSION:**

It is important to keep in mind that the sideband that is being transmitted is actually a band of frequencies approximately 2.7 kc wide. Since the normal I.F. of the Swan Model 600-T Transmitter is a 5500 kc USB I.F. system, those R.F. operating frequencies which are normally LSB must be inverted to LSB before transmission.

On 80 and 40 meters, the normal USB I.F. signal is subtractively heterodyned with the VFO injection frequency in the Mixer stage, and the resultant difference frequency selected at the output of the Mixer is the LSB operating

frequency. For example, if the normal 5500.3 to 5503 kc USB I.F. is heterodyned with the VFO injection frequency of 9400 kc, the resultant output of the Mixer will be the 3899.7 to 3897.0 kc LSB R.F. operating frequency. In other words, the normal USB I.F. frequency has been inverted to a LSB R.F. operating frequency by the subtractive heterodyning process.

On 20, 15, and 10 meters, the normal USB I.F. signal is additively heterodyned with the VFO injection frequency in the Mixer stage, and the resultant sum frequency selected at the output of the Mixer is the USB operating frequency. For example, if the normal 5500.3 to 5503 kc USB I.F. is heterodyned with the VFO injection frequency of 8700 kc, the resultant output of the Mixer will be the 14,200.3 to 14,203.0 kc R.F. operating frequency. Note that on these bands, the inversion process does not take place.

When operation is desired on the opposite sideband, that is, USB on 80 and 40 meters, or LSB on 20, 15, and 10 meters, the I.F. system is changed to a LSB I.F. system by switching the **SIDEBAND SELECTOR** switch to the **OPPOSITE** sideband 5503.3 kc crystal. This positions the double sideband signal generated in the Balanced Modulator stage to the other side of the filter response curve. On 80 and 40 meters, the LSB I.F. signal is subtractively heterodyned with the VFO injection frequency, and the resultant difference frequency selected at the output of the Mixer is the USB R.F. operating frequency. Here again, the LSB I.F. signal has been inverted to the USB R.F. operating frequency. On 20, 15, and 10 meters, the LSB I.F. signal is additively heterodyned with the VFO Injection frequency, and the resultant sum frequency selected at the output of the Mixer is the LSB R.F. operating frequency. (See Table 1 and Table 2.)

TABLE 1. NORMAL SIDEBAND SIGNAL GENERATION

Band	Carrier Oscillator Frequency	A.F. Modulation Frequencies	I.F. Frequency (Filter Passband)	VFO Injection Frequency	Heterodyning Process In Mixer	Signal Output	
						R.F. Carrier Frequency (Suppressed)	Sideband Frequencies
80M	5500.0 kc	300 to 3000 cycles	USB 5500.3 kc to 5503.0 kc	9400.0 kc	Subtractive 9400.0    9400.0 5500.3    5503.0 <u>          </u> 3899.7    3897.0	3900 kc	LSB 3899.7 kc to 3897.0 kc
40M	5500.0 kc	300 to 3000 cycles	USB 5500.3 kc to 5503.0 kc	12600.0 kc	Subtractive 12600.0    12600.0 5500.3    5503.0 <u>          </u> 7099.7    7097.0	7100 kc	LSB 7099.7 kc to 7097.0 kc
20M	5500.0 kc	300 to 3000 cycles	USB 5500.3 kc to 5503.0 kc	8700.0 kc	Additive 8700.0    8700.0 5500.3    5503.0 <u>          </u> 14200.3    14203.0	14200 kc	USB 14200.3 kc to 14203.0 kc
15M	5500.0 kc	300 to 3000 cycles	USB 5500.3 kc to 5503.0 kc	15800.0 kc	Additive 15800.0    15800.0 5500.3    5503.0 <u>          </u> 21300.3    21303.0	21300 kc	USB 21300.3 kc to 21303.0 kc
10M	5500.0 kc	300 to 3000 cycles	USB 5500.3 kc to 5503.0 kc	23000.0 kc	Additive 23000.0    23000.0 5500.3    5503.0 <u>          </u> 28500.3    28503.0	28500 kc	USB 28500.3 kc to 28503.0 kc

TABLE 2. OPPOSITE SIDEBAND SIGNAL GENERATION

Band	Carrier Oscillator Frequency	A.F. Modulation Frequencies	I.F. Frequency (Filter Passband)	VFO Injection Frequency	Heterodyning Process In Mixer	Signal Output	
						R.F. Carrier Frequency (Suppressed)	Sideband Frequencies
80M	5503.3 kc	300 to 3000 cycles	LSB 5503.0 kc to 5500.3 kc	9403.3 kc	Subtractive 9403.3    9403.3 5503.0    5500.3 <u>          </u> 3900.3    3903.0	3900 kc	USB 3900.3 kc to 3903.0 kc
40M	5503.3 kc	300 to 3000 cycles	LSB 5503.0 kc to 5500.3 kc	12603.3 kc	Subtractive 12603.3    12603.3 5503.0    5500.3 <u>          </u> 7100.3    7103.0	7100 kc	USB 7100.3 kc to 7103.0 kc
20M	5503.3 kc	300 to 3000 cycles	LSB 5503.0 kc to 5500.3 kc	8696.7 kc	Additive 8696.7    8696.7 5503.0    5500.3 <u>          </u> 14199.7    14197.0	14200 kc	LSB 14199.7 kc to 14197.0 kc
15M	5503.3 kc	300 to 3000 cycles	LSB 5503.0 kc to 5500.3 kc	15796.7 kc	Additive 15796.7    15796.7 5503.0    5500.3 <u>          </u> 21299.7    21297.0	21300 kc	LSB 21299.7 kc to 21297.0 kc
10M	5503.3 kc	300 to 3000 cycles	LSB 5503.0 kc to 5500.3 kc	22996.7 kc	Additive 22996.7    22996.7 5503.0    5500.3 <u>          </u> 28499.7    28497.0	28500 kc	LSB 28499.7 kc to 28497.0 kc

# INSTALLATION

## POWER SUPPLY:

The Swan Model 600-T built-in power supply provides all the necessary voltages required by the transmitter for 117 volt, 50-60 cycle operation. The transmitter comes complete with a pre-wired plug and cable, all ready for plugging into the AC power source.

## ANTENNA:

Any of the common antenna systems designed for use on the high frequency amateur bands may be used with the Swan 600-T Transmitter, provided the input impedance of the transmission line is not outside the capability of the Pi-output matching network. The transmission line should be of the coaxial cable type. An antenna system which shows a standing wave ratio of less than 4:1 when using 50 or 75 ohm coaxial transmission line, or a system that results in a transmission line input impedance that is essentially resistive, and between 25 and 200 ohms will take power from the transmitter with little difficulty. If open-wire or balanced type transmission line is used with the antenna, a suitable antenna tuner is recommended between the transmitter and the feed line. Methods of construction and operating such tuners are described in detail in the ARRL Antenna Handbook, and similar publications. For operation on the 75 and 40 meter bands, a simple dipole antenna, cut to resonance in the most used portion of the band, will perform satisfactorily. For operation on the 10, 15, and 20 meter bands, the efficiency of the station will be greatly increased if a good directional rotary antenna is used. Remember that even the most powerful transmitter is useless without a proper and efficient antenna system.

## MICROPHONE:

The microphone input is designed for high impedance microphones only. The choice of microphone is important for good speech quality, and should be given serious consideration. The crystal lattice filter in the transmitter provides all the restriction necessary on audio response, and further restriction in the microphone is not required. It is more important to have a microphone with a smooth, flat response throughout the speech range. The microphone plug must be a standard 1/4 in. diameter three contact type.

(a) The tip connection is for push-to-talk relay control.

(b) The ring connection is the microphone terminal.

(c) The sleeve is the common chassis ground.

The microphone manufacturer's instructions should be followed in connecting the microphone cable to the plug. With many microphones, the push-to-talk button must be pressed to make the microphone operative. For VOX operation, this feature may be disabled, if desired, by opening the microphone case and permanently connecting the contacts which control the microphone.

## CABLE CONNECTIONS:

Cable connections for interconnecting the 600-T to the matching Swan Model 600-R Receiver are shown in Figure 2. These cables are supplied with the 600-T.

## RELAY CONTROL:

An RCA phono jack is provided on the back of the 600-T for switching of external accessories. In particular, this jack is used when the Swan Mark II Linear Amplifier is used.

## CARRIER SYNCHRONIZATION:

When operating the 600-T with the 600-R, it is important that the carrier oscillators in each unit be exactly on the same frequency, otherwise, the transmitting and receiving frequencies in the TRANSCEIVE mode will not be the same. To synchronize the 600-T with the 600-R, refer to the CARRIER SYNCHRONIZATION instructions in the 600-R Instruction Manual.

## NOTE

The carrier frequency trimmers on the 600-T have been factory adjusted during transmitter audio tests. Instructions for adjusting transmitter carrier frequencies are contained in the ALIGNMENT section of this manual. It is important to remember that if the transmitter carrier frequencies are ever re-adjusted for any reason, it will be necessary to perform the CARRIER SYNCHRONIZATION procedures again on the 600-R.

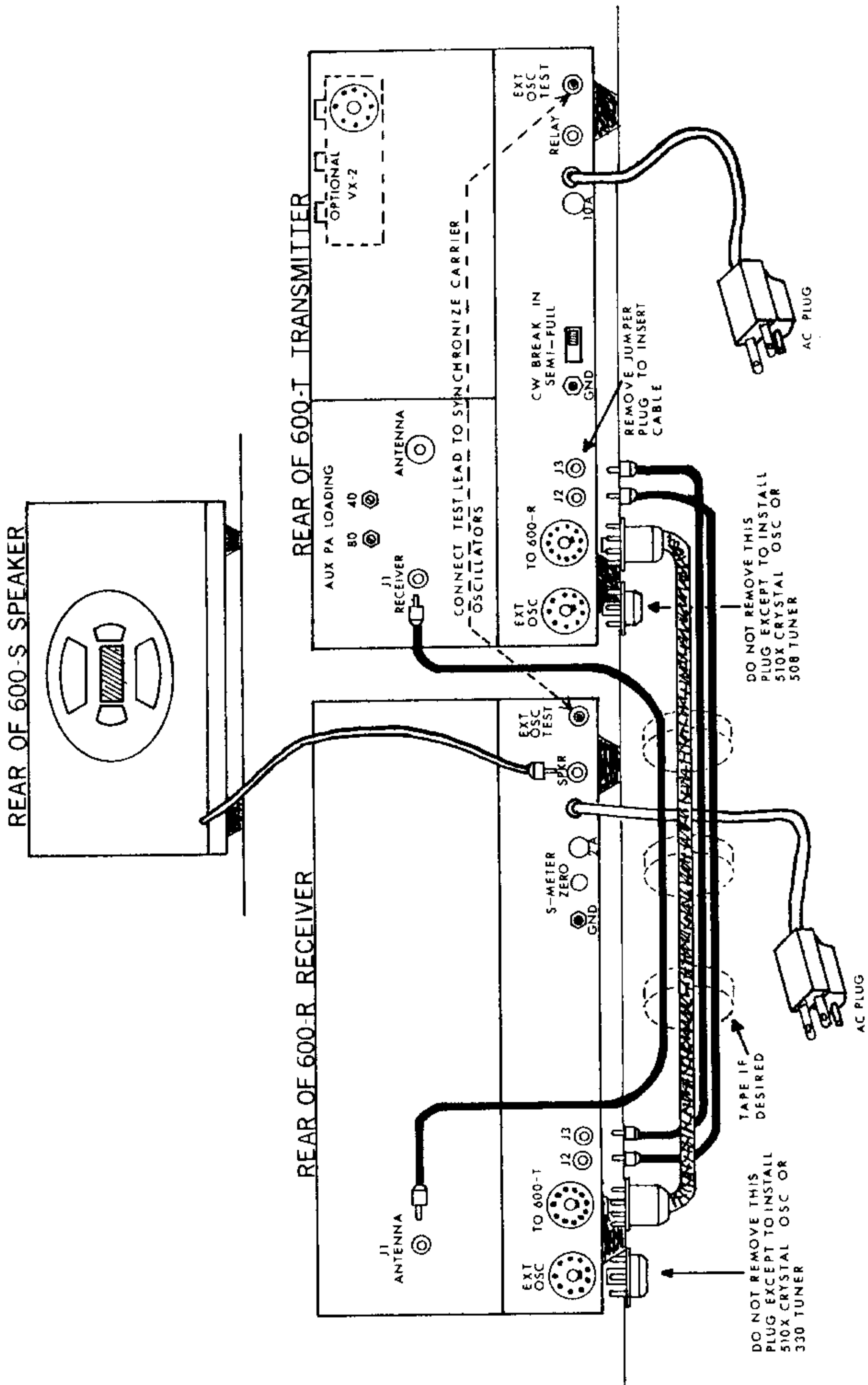

NOTE: THIS CABLE SYSTEM IS FURNISHED WITH THE 600-T TRANSMITTER

FIGURE 2. INTERCONNECTION DIAGRAM 600-R TO 600-T

# OPERATION

## CONTROL FUNCTIONS:

### MIC. JACK

High impedance microphone plugs in here.

### SIDEBAND SELECTOR SWITCH

*CW* – Unbalances Balanced Modulator stage, and inserts carrier.

*NORMAL* – Selects the NORMAL 5500 kc crystal. This provides LSB operation on 80 and 40 meters, and USB operation on 20, 15, and 10 meters.

*OPPOSITE* – Selects the OPPOSITE 5503.3 kc crystal. This positions the Double Sideband signal on the other side of the filter response curve for USB operation on 80 and 40 meters, and LSB operation on 20, 15, and 10 meters.

### FUNCTION SWITCH

*SPOT* – Unbalances Balanced Modulator Stage. Activates all stages of the transmitter *except* the Power Amplifier stage. Allows the transmitter to be "spotted" to the receiver frequency.

*VOX* – Aligns transmitter circuits for voice control operation using VX-2 accessory.

*PTT* – Aligns transmitter circuits for push-to-talk operation using a high impedance microphone.

*TRANS* – 12 volt DC circuit through relay K1 and K2 is completed. Voltage to all stages is applied. Meter reads P.A. Cathode current.

*TUNE* – All circuits for transmit are energized. Balanced Modulator stage is unbalanced. Carrier is fully inserted. Meter reads P.A. Cathode current.

### MIC. GAIN

Controls potentiometer R806 in the grid circuit of V8A. Controls the amount of audio to the Balanced Modulator.

### CAR. BAL.

Controls potentiometer R712 in the Balanced Modulator deflection plate circuit, and permits nulling out the carrier.

### DIAL SET

Zero-beats the calibration markers for accurate dial alignment. Extends the frequency segments for ex-

### P.A. PLATE

Controls C413A/C413B in Pi-network to tune final power amplifier plate to resonance.

### P.A. LOAD

Controls C417A/C417B in Pi-network to match impedance of output load.

### BAND SWITCH

Switches plate coils, and associated capacitors of VFO, VFO Amplifier, Mixer, and Driver. Also switches tank coil of Pi-network and associated capacitors in P.A. output tank.

### HIGH/LOW POWER SWITCH

Controls screen voltage applied to Power Amplifier tubes. Controls P.A. Bias to Power Amplifier Tubes.

### KEY JACK

CW key plugs into this jack.

### ON-OFF SWITCH

Turns power supply on and off.

### PANEL METER

Reads P.A. Cathode current only.

### TUNING EYE

Indicates relative output of transmitter (maximum closing of eye). Also used to check modulation level.

### P.A. BIAS (HIGH POWER)

Controls R404, located on right side of chassis. Adjusts HIGH POWER P.A. idling current.

### P.A. BIAS (LOW POWER)

Controls R409, located on bottom of chassis. Adjusts LOW POWER P.A. idling current.

### CW BREAK-IN

*SEMI* – This position is used in conjunction with the Model VX-2 VOX accessory, and permits semi-break-in CW operation.

*FULL* – This position is used for Full break-in CW operation. A separate antenna is required for the transmitter and receiver, or the addition of an electronic T/R antenna relay.

## WARNING

*Dangerous high voltage is present on the plates of the power amplifier tubes whenever the power supply is energized. Never turn power on when the power amplifier cover is removed. High voltage is also present underneath the chassis below the clear plastic HIGH VOLTAGE WARNING plate.*

## PRE-OPERATING ADJUSTMENTS

Perform the following adjustments before plugging the line cord into the AC receptacle.

1. Turn POWER switch to OFF position.
2. Set Function Switch to PTT position.
3. Connect a wire from earth ground to the ground stud located on the rear of the chassis. NOTE: This step is recommended, but not essential if the 117 volt receptacle is grounded with the third ground pin.
4. Connect a 50 to 75 ohm antenna to the ANTENNA coaxial connector on the rear of the chassis, or connect a dummy load to the transmitter.
5. Be sure that all plugs are fully inserted into their respective sockets. As received from the factory, the 600-T is prepared to operate on its own, having jumper plugs in the "EXT OSC" socket, in the "TO 600-R" socket, and from J2 to J3.
6. Insert the microphone plug into the MIC. jack on the front panel, and/or plug a CW key into the KEY jack.
7. Plug the 117 VAC power cord into a 117 volt, 50-60 cycle receptacle. If the receptacle to be used does not have provisions for the third pin, which is a grounding pin, an adaptor will be required, or the pin may be cut off, and a separate ground wire run to the 600-T chassis. Adaptors are available from electronic or hardware stores.

## CAUTION

*THE 600-T MAY BE TUNED TO FREQUENCIES OUTSIDE THE AMATEUR BANDS. DO NOT OPERATE THE TRANSMITTER UNLESS YOU ARE WITHIN YOUR PERMITTED BAND LIMITS.*

## TRANSMITTER OPERATION

### SPECIAL NOTES

*Read the following paragraph carefully. Be sure that you understand and remember these procedures before tuning the transmitter.*

1. The most important detail to keep in mind when tuning your Swan 600-T Transmitter, is that the P.A. PLATE MUST BE RESONATED AS QUICKLY AS POSSIBLE! The P.A. tubes are dissipating all the power input when they are not in resonance, and can be permanently damaged in just a few seconds. Once resonance has been established, the P.A. tubes can be operated at full power input in the TUNE position for a considerable length of time, although we recommend 30 seconds as a safe maximum. But it is most important to realize that the 30 second limit assumes that the P.A. PLATE has been IMMEDIATELY resonated. This rule applies generally to all transmitters.
2. P.A. PLATE resonance may be accomplished by:
  - (a) tuning for the "dip" in P.A. Cathode Current, or
  - (b) tuning for maximum transmitter output as indicated by the tuning eye.
3. In the 600-T, the meter indicates total P.A. Cathode Current. The P.A. PLATE should generally be tuned for the "dip" in meter reading.
4. The 600-T tuning eye indicates relative output level. As output power increases, the tuning eye will close more and more. Usually, the point of maximum eye closing will correspond with the "dip" in meter reading. If a slight difference is noted, tune for maximum output, that is, maximum eye closing.

*READ ITEMS (1) THROUGH (4) OVER AGAIN CAREFULLY TO BE SURE THAT YOU FULLY UNDERSTAND THEM.*

5. When first tuning the 600-T, you may find the 30 second time limit too short. In that event, switch back to PTT position for a minute or so, and then resume the tuning procedures. With experience, transmitter tuning will require only 10 to 15 seconds. Do not tune more often than necessary. You should not have to retune except when changing bands or antennas. The P.A. tubes will last for many months or even years of normal operating, but constant tuning at full grid drive will shorten their life considerably.

## TRANSMITTER TUNING

- ① Turn POWER switch to the ON position. This will apply filament, bias, medium and high voltage to the transmitter.
- ② Wait approximately one minute to allow the tube filaments to reach operating temperature. During this period, perform the following steps.
  - a. Set SIDEBAND SELECTOR switch to NORMAL sideband.
  - b. Rotate MIC. GAIN control fully counterclockwise.
  - c. Rotate CAR. BAL. control to the 12 o'clock position.
  - d. Rotate GRID tuning control to its #5, or mid-point position.
  - e. Rotate P.A. LOAD control fully counterclockwise.
  - f. Rotate P.A. PLATE control to its #5, or mid-point position.
  - g. Set HIGH/LOW POWER switch to LOW position.
  - h. Set BAND switch to desired band.
  - i. Rotate MAIN TUNING dial to desired operating frequency.
- ③ Move the Function Switch to TRANS. mode, and quickly rotate the CAR. BAL. control for minimum meter reading. If the control has no effect at this time, do not be concerned. The P.A. (Power Amplifier) stage is now "resting" or "idling", and there is no grid drive being applied. The meter is reading "idling" current, which should be about 50 ma. in LOW POWER, and about 80 ma. in HIGH POWER as read on the 0 to 800 ma. meter. The permissible idling range in LOW POWER is between 40 and 60 ma., and in HIGH POWER between 70 and 90 ma. If the P.A. is idling above or below these ranges, adjust the P.A. BIAS as follows:
  - a. Switch HIGH/LOW POWER switch to HIGH.
  - b. With the Function Switch in TRANS., adjust the HIGH POWER P.A. BIAS CONTROL on the right side of the chassis until the meter reads 80 ma. idling current. An adjusting hole is provided in the cabinet for this purpose.
  - c. Switch HIGH/LOW POWER switch to LOW.

- d. With the Function Switch in TRANS., adjust the LOW POWER P.A. BIAS CONTROL through the bottom cover until the meter reads 50 ma. idling current.
- e. Switch back to HIGH POWER and check idling current. Re-adjust if necessary.
- f. Switch back to LOW POWER and check idling current. Re-adjust if necessary.

### NOTE

*UP TO THIS POINT, THE TRANSMITTER HAS BEEN MERELY "IDLING", AND THERE HAS BEEN NO PARTICULAR TIME LIMIT INVOLVED. THE FOLLOWING STEP BEGINS APPLYING GRID DRIVE, AND REQUIRES CAUTION AND OBSERVANCE OF THE RECOMMENDED 30 SECOND TIME LIMIT.*

- ④ With the HIGH/LOW POWER switch still in LOW, and the Function Switch still in TRANS mode:
  - a. Set CAR. BAL. control to either 9 or 3 o'clock.
  - b. Rotate the GRID control for maximum meter reading.
  - c. IMMEDIATELY rotate the P.A. PLATE control for minimum meter reading, or "dip". This is the critical adjustment known as "resonating" the plate circuit, and MUST BE PERFORMED QUICKLY to preserve P.A. tube life. An alternate method of resonating the plate circuit is to rotate the P.A. PLATE control for maximum closing of the tuning eye.
  - d. Re-adjust CAR. BAL. control for minimum meter reading, or maximum tuning eye opening.
  - e. Set HIGH/LOW POWER switch to HIGH.
- ⑤ Switch Function Switch to TUNE position, and observe meter reading. Begin advancing the P.A. LOAD control clockwise in small increments, each time "dipping" the P.A. PLATE control for minimum meter reading. As the P.A. LOAD control is turned further clockwise, the P.A. PLATE "dip" will become more shallow, until finally it may be difficult to see the dip.

The proper degree of loading is when the dip is about 10 percent down from the maximum off-resonance reading. In other words, if the meter reads 700 ma. when the P.A. PLATE is off resonance, it should dip to about 630 ma. at resonance. Or, if the meter reads

800 ma. off resonance, then adjust P.A. LOAD so that the P.A. PLATE dips to 720 ma. at resonance. Refer to the chart below for additional clarification.

## NOTE

EXERCISE CAUTION WHEN TURNING THE

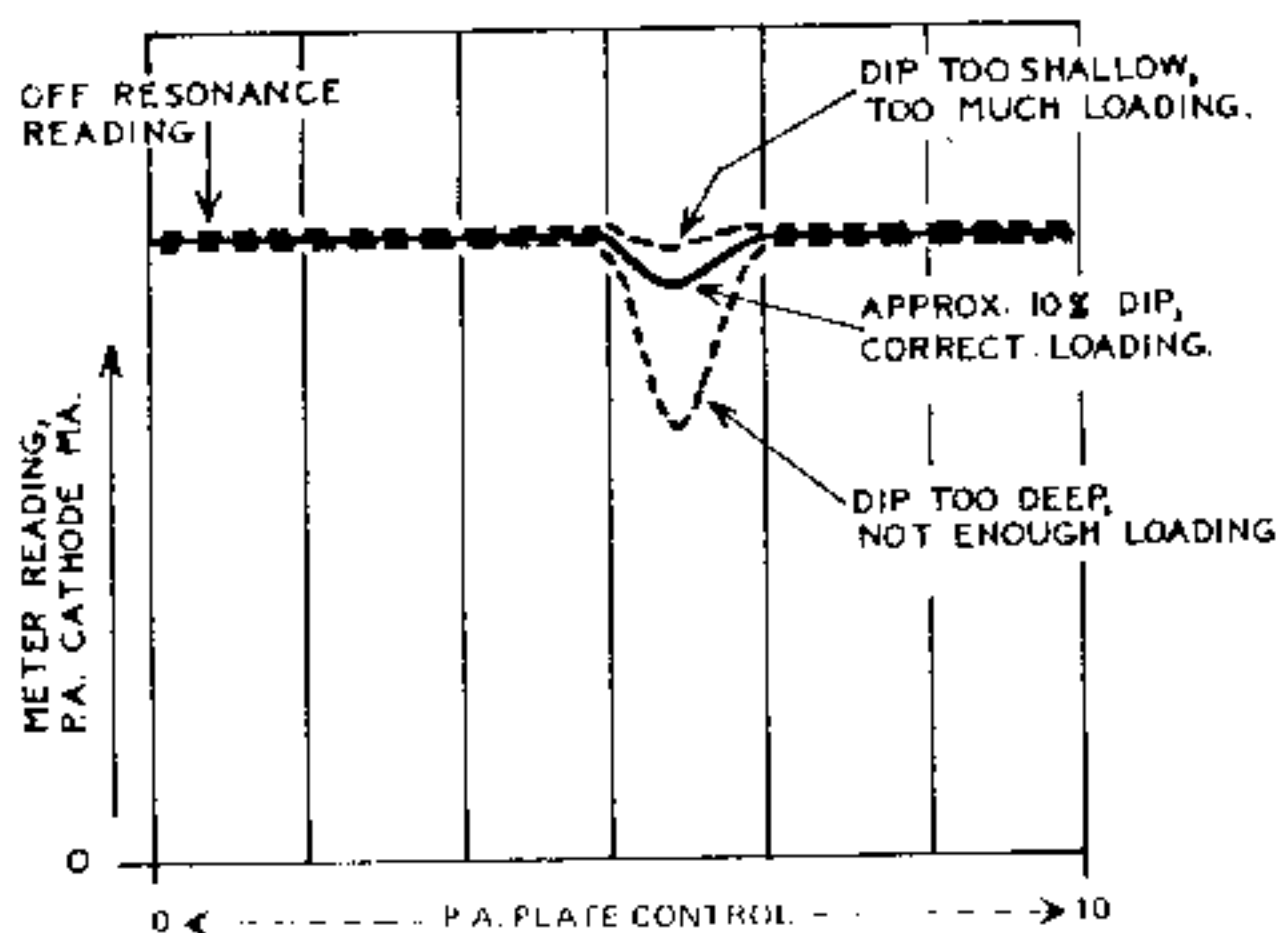

Illustrating proper P.A. LOAD adjustment as indicated by "dip" in P.A. Cathode Current when turning P.A. PLATE control through resonance.

A Tuning Chart is provided on the last page of this manual for recording the approximate settings of the P.A. GRID, P.A. PLATE, and P.A. LOAD controls.

The specific meter reading is not vitally important, and may vary considerably, being less on 10 meters than on 80 meters. Also, tube condition and line voltage can affect the meter reading. It will normally read 700 ma. or more when off resonance. With high line voltage and new tubes, it may be as high as 800 ma. Remember, the P.A. should never be held out of resonance for more than a second or two, just long enough to observe the meter reading and tune for the "dip", or the alternate method of switching to TUNE and adjusting P.A. load and P.A. PLATE controls for maximum closing of the tuning eye.

IS POSSIBLE TO TURN THE ADJUSTMENT SCREW ALL THE WAY OUT OF THE CAPACITOR.

- ⑦ The preceding steps completes transmitter tuning. Return the Function Switch to the PTT position.
- ⑧ Note that the Swan 600-T Transmitter can be operated at reduced power (about 50 percent of full power) when the HIGH/LOW POWER switch is placed in the LOW POWER position. However, the transmitter should always be tuned up to full power before switching to LOW POWER.

## SINGLE SIDEBAND VOICE TRANSMISSION:

After tuning up as outlined above, switch to PTT. Press the microphone push-to-talk switch and carefully set the CAR. BAL. control for minimum meter reading. While speaking into the mike, slowly rotate the MIC. GAIN control clockwise until peak readings of 225 to 250 ma. are obtained. With most microphones, the MIC. GAIN control will be set between 9 and 12 o'clock, but it may vary considerably. The ALC circuit will help limit cathode current, but turning the MIC. GAIN up too high will still produce flat-topping and spurious signals. So it is important to hold it down. The meter is quite heavily damped, and its reading with average voice modulation may not look very impressive, but the voice peaks are going well over the 600 watt rating of your Swan Transmitter.

## AM TRANSMISSIONS (Single Sideband with Carrier)

- ⑥ Some 80 and 40 meter antennas may not present a 50 ohm non-reactive load to the transmitter, and it may not be possible to achieve proper load adjustment with the front panel controls. Auxiliary loading adjustments will be found on the back of the P.A. compartment. When the transmitter is coupled to a 50

- ① Tune transmitter to full output on single sideband as described above.

### CW OPERATION (MANUAL):

In Manual CW operation, it will be necessary to switch the Function Switch to TRANS. when transmitting, and back to PTT when receiving.

- ① Tune transmitter to full output on single sideband as described above.
- ② Insert a CW key in the KEY jack on the front panel.
- ③ Set CW BREAK-IN switch on rear of chassis to "SEMI" position.
- ④ Set SIDEBAND SELECTOR switch on front panel to "CW" position.
- ⑤ Switch the Function Switch to TRANS. and commence keying. After completion of keying, switch the Function Switch back to PTT for reception.

### CW OPERATION (SEMI-BREAK-IN):

When the VOX accessory, Model VX-2, is used, Semi-Break-In CW operation may be employed. No separate receiving antenna is required. A slight delay will be noticed before receiver comes back on after keying is stopped.

- ① Tune transmitter to full output on single sideband as described above.

② Insert a CW key in the KEY jack on the front panel.

Information for building an electronic T/R antenna relay can be found in the ARRL Radio Amateur's Handbook. Additionally, if the 600-T is to be operated with a receiver other than the matching Swan Model 600-R Receiver, some method of muting the other receiver must be devised. This information can also be found in the ARRL handbook. Muting is automatically accomplished when the 600-T and 600-R are interconnected, and the Function Switch on the 600-R is set to the EXT. MUTE position.

- ① Tune transmitter to full output on single sideband as described above.
- ② Insert a CW key in the KEY jack on the front panel.
- ③ Set CW BREAK-IN switch on rear of chassis to "FULL" position.
- ④ Set SIDEBAND SELECTOR switch on front panel to "CW" position.
- ⑤ Set Function Switch to TRANS. position.
- ⑥ When the key is pressed, the receiver will turn off through the muting circuit, and the transmitter will come on with the first dot or dash. When the key is released, the receiver will turn on immediately, allowing signals to be heard between keying characters.

### FREQUENCY SHIFT KEYING (FSK):

① Tune transmitter to full output on single sideband as described above.

④ Set the Function Switch to TRANS and com.

④ Set the 600-R VFO CONTROL switch to the XCV-T

mission, switch the Function Switch back to PTT for receiving.

### SIDETONE OSCILLATOR:

A sidetone oscillator circuit is included in the 600-T, and permits CW monitoring when the 600-T is interconnected with the 600-R. An 800 cycle tone will be heard coming from the speaker or headphones. The strength or volume of the sidetone may be changed as desired by adjusting the MIC. GAIN control on the transmitter.

### OFF-SET CW TRANSMIT FREQUENCY:

When transmitting in CW mode, the carrier frequency is moved approximately 800 cycles higher than the SSB carrier frequency, placing it inside the passband of the crystal lattice filter. This frequency shift is termed "OFF-SET CW TRANSMIT FREQUENCY", and avoids the problems encountered when the receive and transmit frequency are exactly the same. When receiving CW, the receiver must be tuned off frequency several hundred cycles in order to hear

⑤ Set the PRESELECTOR control on the 600-R to the proper band area.

⑥ Set the Function Switch on the 600-R to the 100 kc calibrator position.

⑦ Zero-beat the calibrator marker using the 600-T DIAL SET control.

⑧ The 600-T Main Tuning Dial is now calibrated for normal phone band coverage. The 0 to 200 dial scale will now tune from 3.8 to 4.0 mc, 7.1 to 7.3 mc, 14.2 to 14.4 mc, and 21.3 to 21.5 mc, respectively.

The dial reading is added to the bandswitch setting. For example: In the 3.8 position, a dial reading of 100 indicates a frequency of 3.9 mc, or 3900 kc.

In the 10M position, the reading obtained from the green 0 to 500 scale is added to the frequency that the DIAL SET indicator line is aligned with. For example: When the DIAL SET is aligned on 28.5, the MAIN TUNING will tune 28.5 to 29.0 mc. Thus, if the dial reads 200, the indicated frequency is 28.7 mc, or 28,700 kc.

## 600-R/600-T FREQUENCY COVERAGE CHART

### LOWER FREQUENCY SEGMENTS

Bandswitch Position	Tuning Range with Dial Set At 0	Tuning Range with Dial Set At -100	Tuning Range with Dial Set At -200	Tuning Range with Dial Set At -300	Tuning Range with Dial Set At -400
3.8	3.8 - 4.0	3.7 - 3.9	3.6 - 3.8	3.5 - 3.7	3.4 - 3.6
7.1	7.1 - 7.3	7.0 - 7.2	6.9 - 7.1	6.8 - 7.0	6.7 - 6.9
14.2	14.2 - 14.4	14.1 - 14.3	14.0 - 14.2	13.9 - 14.1	13.8 - 14.0
21.3	21.3 - 21.5	21.2 - 21.4	21.1 - 21.3	21.0 - 21.2	20.9 - 21.1

### HIGHER FREQUENCY SEGMENTS

Bandswitch Position	Tuning Range with Dial Set At 0	Tuning Range with Dial Set At +100	Tuning Range with Dial Set At +200	Tuning Range with Dial Set At +300	Tuning Range with Dial Set At +400
3.8	3.8 - 4.0	3.9 - 4.1	4.0 - 4.2	4.1 - 4.3	4.2 - 4.4
7.1	7.1 - 7.3	7.2 - 7.4	7.3 - 7.5	7.4 - 7.6	7.5 - 7.7
14.2	14.2 - 14.4	14.3 - 14.5	14.4 - 14.6	14.5 - 14.7	14.6 - 14.8
21.3	21.3 - 21.5	21.4 - 21.6	21.5 - 21.7	21.6 - 21.8	21.7 - 21.9

### 10 METER FREQUENCY SEGMENTS

Bandswitch Position	Tuning Range with Dial Set At 28.5	Tuning Range with Dial Set At 28.0	Tuning Range with Dial Set At 29.0	Tuning Range with Dial Set At 29.2
10M	28.5 - 29.0	28.0 - 28.5	29.0 - 29.5	29.2 - 29.7

- Use 100 kc calibrator position for exact setting of 100 kc increments.
- Lock the DIAL SET control to hold in position. This need not be a hard lock, but just enough drag to make turning tight.
- Calibration accuracy of the MAIN TUNING dial is closest in the normal phone band ranges. In lower portions of each band, that is, in the CW bands, check frequency carefully with 100 kc and 25 kc calibration markers.

# ALIGNMENT AND TROUBLESHOOTING

The following procedures are given in the order performed during the factory alignment for the transmitter. For home servicing, only partial alignment may be necessary. Read all procedures carefully before commencing either partial or complete alignment. See Figures 3, 4, and 5 for component placement. The following equipment is recommended for complete alignment.

1. Audio Signal Generator.
2. 500 watt dummy load with output meter.
3. Vacuum tube voltmeter (VTVM).
4. Field strength meter.

## TRANSMITTER ALIGNMENT:

The alignment of the transmitter circuits involves the adjustment of tuned circuits in the VFO Amplifier V1, Mixer V2, and Driver V3. A dummy load should be connected to the antenna jack during this series of adjustment.

### VFO AMPLIFIER PLATE CIRCUIT:

- ① Set MAIN TUNING dial to 0.
- ② Rotate DIAL SET control to 0.

### MIXER AND DRIVER PLATE CIRCUIT:

- ③ Set MAIN TUNING dial to 0.
- ④ Rotate DIAL SET control to 0.
- ⑤ Set BAND SWITCH to 3.8, 7.1, 14.2, 21.3, or 10M position. (See chart below.)
- ⑥ Remove screen voltage from V4 and V5 by disconnecting the orange wire from the terminal strip immediately adjacent to the base of V5. (Point B, Figure 5.)
- ⑦ Loosely couple field strength meter to C303 (off pin 5 of V4) with alligator clip on capacitor body. (Point C, Figure 5.)
- ⑧ Connect VTVM across R402, 1K resistor between pins 1 and 6 of terminal strip, using the 30 volt DC scale. Connect the positive lead to pin 1 (Point D, Figure 5), and the negative lead to pin 6 (Point E, Figure 5.)
- ⑨ Place Function Switch in TRANS position.
- ⑩ Adjust HIGH POWER P.A. BIAS control fully clockwise. (Maximum Bias Voltage.)

- ③ Connect VTVM from pin 1 of the Mixer (Point A, Figure 5), V2, to ground.
- ④ Set VTVM on 30 volt AC scale.
- ⑤ Set BAND SWITCH to 7.1, 21.3, or 10M (28.5) position.
- ⑥ Place Function Switch in TRANS position.

shown in the chart below.

- ⑩ Place Function Switch in the TUNE position.
- ⑪ Adjust Mixer and Driver coils for peak VTVM reading.

	P.A. Grid Tuning	Adjust

peak at same time, since it is possible to tune the coils to the VFO frequency on 10 meters. Care must be taken that the coils be tuned properly. Following the above procedures, replace the orange screen voltage wire to pin 1 of terminal strip adjacent to V5. (Point B, Figure 5.)

- ⑫ Disconnect all test equipment.
- ⑬ Adjust HIGH POWER P.A. BIAS control R404 for 80 ma. idling current using the panel meter.

### CARRIER FREQUENCY ADJUSTMENT:

- ① Tune transmitter up on 14,200 kc into a dummy load.
- ② Balance out the carrier.
- ③ Feed 1500 cycles of audio from the Audio Generator into the MIC. input jack.
- ④ Adjust the gain of the Audio Generator, and the MIC. GAIN control until the wattmeter reads about 10 to 15 watts.
- ⑤ Adjust both slugs of the Balanced Modulator transformer T701, for maximum output. (See Figure 5.)
- ⑥ Adjust the I.F. Amplifier, V6, transformer, T601, for maximum output. (See Figure 4.)
- ⑦ Increase the gain of the Audio Generator until the wattmeter reads 40 watts. Sweep the generator down to 300 cycles.
- ⑧ Adjust the NORMAL SIDEBAND CARRIER FREQUENCY ADJUSTMENT TRIMMER, C1002, for a reading of 10 watts. (See Figure 5.)
- ⑨ Switch SIDEBAND SELECTOR switch to OPPOSITE.
- ⑩ Adjust OPPOSITE SIDEBAND CARRIER FREQUENCY ADJUSTMENT TRIMMER, C1001, for a reading of 10 watts. (See Figure 5.)
- ⑪ Re-check with Audio Generator set at 1500 cycles and 40 watts. Sweep down to 300 cycles and re-adjust CARRIER FREQUENCY TRIMMERS, if necessary for 10 watts input.

### P.A. NEUTRALIZATION:

- ① Set BAND SWITCH to 14.2 position.
- ② Set MAIN TUNING dial to 0.
- ③ Set DIAL SET dial to 0.

- ④ Set P.A. LOAD control fully counterclockwise.
- ⑤ Set P.A. PLATE control fully counterclockwise.
- ⑥ Set CARRIER BALANCE control to 9 o'clock position.
- ⑦ Peak the P.A. GRID control.
- ⑧ Adjust CARRIER BALANCE control for a meter reading of 200 ma.
- ⑨ Re-peak P.A. GRID control, and adjust CAR. BAL. control until the meter reads 200 ma. when the P.A. GRID is peaked.
- ⑩ Slowly turn the P.A. PLATE control through resonance. Cathode current should dip smoothly and rise to 200 ma. on the low capacity side of resonance. If, instead, there is a peak above 200 ma. either side of the dip, stop rotation of the P.A. PLATE control at the peak and adjust C410 to reduce the plate current to 200 ma. Repeat the above check and re-adjust as necessary to obtain the desired smooth dip.
- ⑪ Normally, when the transmitter has been neutralized on 20 meters, 80, 40, 15, and 10 meters also have been neutralized. However, it is recommended that neutralization be checked on these bands also. Use the above procedures, and set the BAND SWITCH and tuning dials as follows:

Band Switch	Main Tuning Dial	Dial Set Dial
3.8	0	0
7.1	100	0
21.3	0	0
10M	0	28.5

### NOTE

*THE 600-T TRANSMITTER WAS DESIGNED FOR RCA 6KD6 POWER AMPLIFIER TUBES. ALTHOUGH OTHER MAKES MAY BE USED, NEUTRALIZATION OF THE POWER AMPLIFIER MAY BE DIFFICULT OR IMPOSSIBLE. THEREFORE, IT IS RECOMMENDED THAT IF REPLACEMENT OF THE POWER AMPLIFIER TUBES IS NECESSARY, A MATCHED PAIR OF RCA 6KD6'S BE USED. A MATCHED PAIR OF TUBES WILL ALSO GIVE LONGER TUBE LIFE.*

### VFO ALIGNMENT:

A trimmer condenser is provided for each VFO range. Trimmer adjustment for the five VFO ranges is through the Top Cover of the VFO compartment. An insulated adjusting tool is recommended. Dial tracking has been factory preset by pruning the coils, and will not ordinarily require

### CARRIER BALANCE:

A Carrier Balance control is provided on the front panel, and is labeled CAR. BAL. This control permits insertion of carrier during AM operation, and as an aid in tuning the transmitter circuits. In addition to the carrier control, there is another control located under the chassis near the Bal-

When dial calibration changes beyond the adjusting range indicated on the DIAL SET dial, calibration may be restored by carefully adjusting the trimmer for that range.

**VFO FREQUENCY CHART**

Dial Frequency	VFO Frequency
3500	9000
3800	9300
4000	9500
7000	12,500
7200	12,700
7300	12,800
14,000	8500
14,200	8700

called a "Quadrature control", and is of the screwdriver adjust, trimmer type. It will seldom require adjustment, but is recommended particularly when the Balanced Modulator tube is replaced. To adjust the Quadrature control:

- ① Connect a dummy load to the transmitter.
- ② Connect the VTVM across the dummy load, or across the coax. line.
- ③ Tune transmitter for maximum output on 14,200 kc.
- ④ Switch Function Switch to TRANS position.
- ⑤ Balance the carrier with the front panel CAR. BAL. control.
- ⑥ Adjust R702, the Quadrature control trimmer, for carrier null. (See Figure 5.)

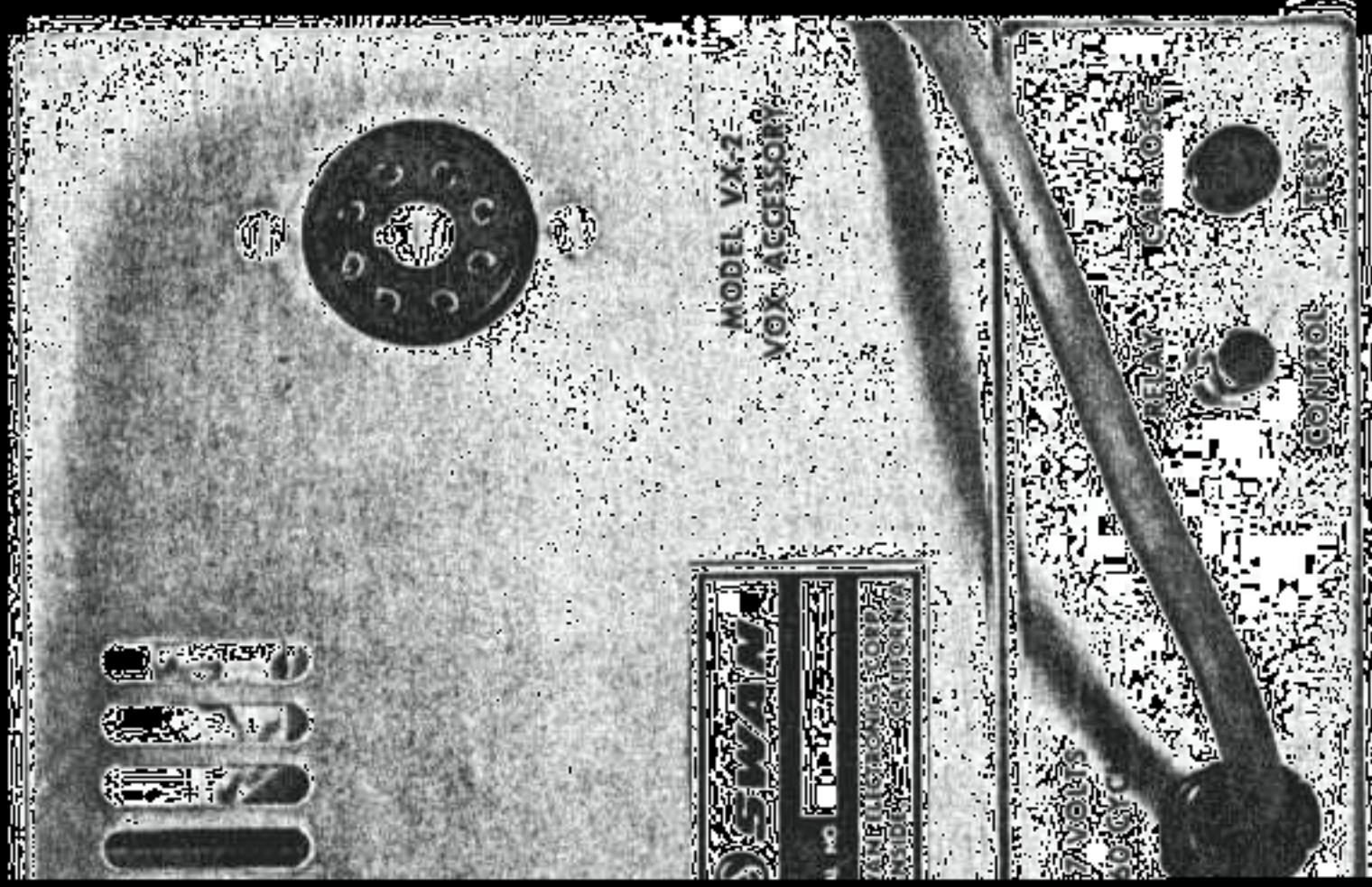



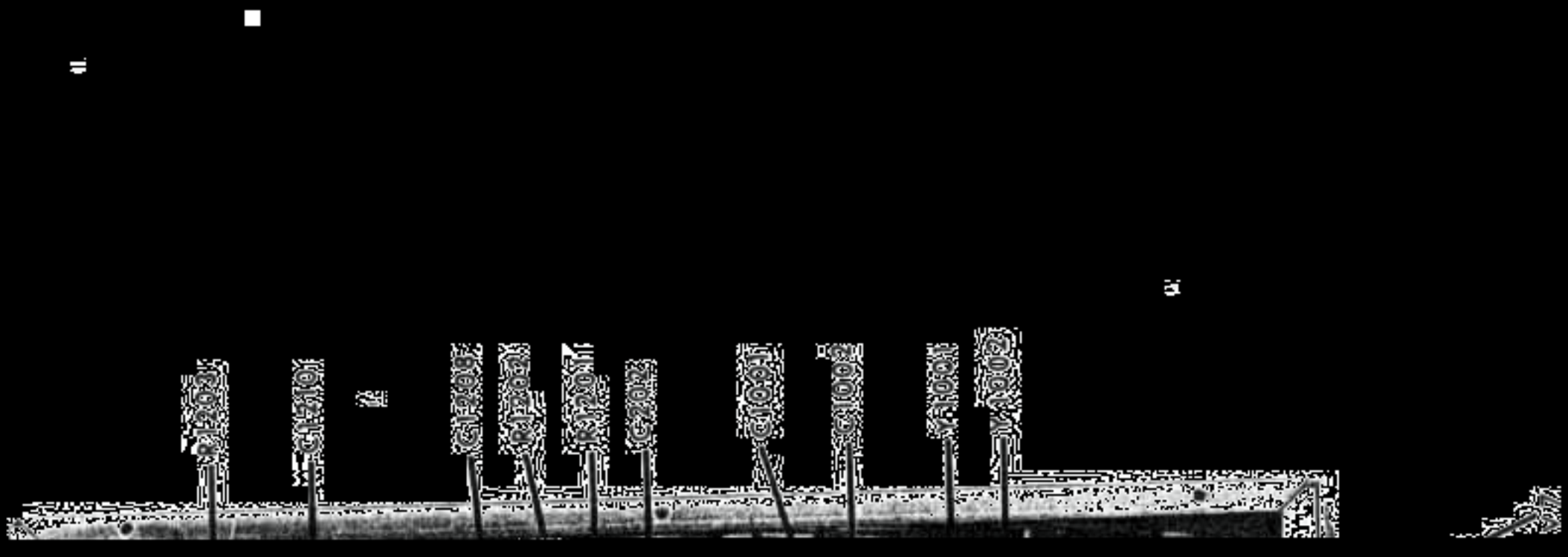

**TROUBLESHOOTING GUIDE**

SYMPTOM	POSSIBLE CAUSE
P.A. Idling Current Unstable	<ol style="list-style-type: none"> <li>1. Defective 6KD6</li> <li>2. Defective P.A. BIAS Pot. R404, R409</li> <li>3. Defective Bias Supply</li> </ol>
Inability to load to 700-800 ma.	<ol style="list-style-type: none"> <li>1. P.A. GRID improperly tuned</li> <li>2. BAND SWITCH improperly set</li> <li>3. Antenna not resonant at freq.</li> <li>4. Defective Transmission Line</li> <li>5. V1, V2, V3, V6 defective</li> <li>6. V4 and V5 Flat</li> </ol>
Insufficient Carrier Suppression	<ol style="list-style-type: none"> <li>1. CAR. BAL. control improperly adjusted</li> <li>2. Defective 6JH8 Balanced Modulator</li> <li>3. Carrier Oscillator Frequency incorrect</li> </ol>
Insufficient Sideband Suppression	<ol style="list-style-type: none"> <li>1. Excessive MIC. GAIN</li> <li>2. Incorrect P.A. LOAD adjustment</li> <li>3. Carrier Oscillator Frequency Incorrect</li> </ol>

**VOLTAGE CHART**

TUBE TYPE	PIN NO.											
	1	2	3	4	5	6	7	8	9	10	11	12
V1-12BZ6	-08	.53	0	12.6 AC	170	64	0	-	-	-	-	-
V2-12BE6	*	0	12.6 AC	0	240	140	-23	-	-	-	-	-
V3-6GK6	0	-.75	0	6.3 AC	12.6 AC	0	280	205	0	-	-	-
V4-6KD6	12.6 AC	.25	250	0	-77	NC	NC	NC	-77	0	250	6.3 AC
V5-6KD6	6.3 AC	.25	250	0	-77	NC	NC	NC	-77	0	250	0
V6-12BA6	.02	0	0	12.6 AC	245	95	1.3	-	-	-	-	-
V7-6JH8	18	18	150	6.3 AC	0	-3.2	0	175	175	-	-	-
V8-12AX7	72	-.45	0	0	12.6 AC	102	0	5.6	0	-	-	-

NOTE: Voltages measured in TRANS position, with HIGH/LOW POWER switch in HIGH position.

All measurements were taken using a Hewlett-Packard Model 410B VTVM.

\*Will vary from band to band. Nominal voltage will be approximately -6 thru -18 VDC.

All voltage measurements are DC unless otherwise indicated.

Plate voltage on the power amplifiers with no load should be approximately 900 VDC with line voltage of 120 VAC. With key down, voltage should be approximately 760 VDC.

P.A. TUNING CHART

BAND	FREQ	P.A. GRID	P.A. PLATE	P.A. LOAD
80 METERS				
40 METERS				
20 METERS				

BAND	FREQ	P.A. GRID	P.A. PLATE	P.A. LOAD
20 METERS				
15 METERS				
10 METERS				

## PARTS LIST

Ref. Symbol	Description	Part No.	Ref. Symbol	Description	Part No.
<b>CAPACITORS</b>			C419	1000, 1000V Feedthru	077-001
C101	.1, 400V Mica	085-024	C420	1000, 1000V Feedthru	077-001
C102	.01 +80-20% 500V Disc	072-023	C421	5, 5% NPO Disc	084-022
C103	.01 +80-20% 500V Disc	072-023	C422	.01, +80-20% 500V Disc	072-023
C104	.002 20% 500V Disc	072-018	C423	.01, +80-20% 500V Disc	072-023
C105	24, 5% 500V Mica	088-036	C601	.01, +80-20% 500V Disc	072-023
C106	30, 5% 500V Mica	084-011	C602	.01, +80-20% 500V Disc	072-023
C107	.01, +80-20% 500V Disc	072-023	C603	.01, +80-20% 500V Disc	072-023
C201	.002, 20% 500V Disc	072-018	C604	.002, 20% 500V Disc	072-018
C202	1 MF, 200V Molded Mica	085-028	C701	430, 10% N2200 Disc	084-086
C203	.01, +80-20% 500V Disc	072-023	C702	220, 10% N2200 Disc	084-084
C204	.002, 20% 500V Disc	072-018	C703	.01, +80-20% 500V Disc	072-023
C205	33, 5%, NPO Disc	084-009	C704	.01, +80-20% 500V Disc	072-023
C206	50, 5% N33 Disc	084-053	C705	.01, +80-20% 500V Disc	072-023
C207	20, 5% NPO Disc	084-001	C706	220, 20% 500V Disc	072-017
C208	27, 5% NPO Disc	084-066	C707	.01, +80-20% 500V Disc	072-023
C209	136, Variable	074-057	C708	.002, 20% 500V Disc	072-018
C210	470, 5% 500V Mica	088-032	C801	100, 20% N1500 Disc	084-023
C211	2, 10% Tubular	071-002	C802	.01, +80-20% 500V Disc	072-023
C301	.002, 20% 500V Disc	072-018	C803	5, 450V Electrolytic	073-041
C302	.002, 20% 500V Disc	072-018	C804	.01, +80-20% 500V Disc	072-023
C303	.002, 20% 500V Disc	072-018	C805	100, 20% N1500 Disc	084-023
C304	50, 5% N33 Disc	084-053	C806	.001, 20% 500V Disc	072-007
C305	20, 5% NPO Disc	084-001	C807	.001, 20% 500V Disc	072-007
C306	43, 5% NPO Disc	084-096	C808	.001, 20% 500V Disc	072-007
C307	136, Variable	074-057	C809	.0047, 10% 500V Disc	072-028
C308	.01, +80-20% 500V Disc	072-023	C810	.02 +80-20% 500V Disc	072-023
C309	470, 5% 500V Mica	088-032	C901	.002, 20% 500V Disc	072-018
C401	.1, 200V Tubular	085-020	C902	.001, 20% 500V Disc	072-023
C402	.047, 20% 200V Molded	085-026	C1001	25, Variable	075-018
C403	500V Disc	072-018	C1002	25, Variable	075-018
C404	.01, +80-20% 500V Disc	072-023	C1003	10, 5% NPO Disc	084-060
C405	.01, +80-20% 500V Disc	072-023	C1004	Not Used	
C406	.01, +80-20% 500V Disc	072-023	C1005	10, 5% NPO Disc	084-060
C407	.01, +80-20% 500V Disc	072-023	C1006	.002, 20% 500V Disc	072-018
C408	.002, 20% 2KV Disc	072-009	C1007	1, 10% Tubular	071-001
C409	.002, 20% 2KV Disc	072-009	C1008	30, 15V Electrolytic	073-047
C410	20, Variable	074-010	C1009	.01, +80-20% 500V Disc	072-023
C411	270, 5% 2500V Silver Mica	088-025	C1010	270, 2% 500V Mica	088-014
C412	270, 5% 2500V Silver Mica	088-025	C1011	270, 2% 500V Mica	088-014
C413A	180, Variable	074-023	C1101	13, Variable	075-005
C413B	180, Variable	074-023	C1102	Selected Value	
C414	100, 6KV Disc	084-062	C1103	13, Variable	075-005
C415	265-880, Mica Compression	089-012	C1104	Selected Value	
C416	265-880, Mica Compression	089-012	C1105	13, Variable	075-005
C417A	410, Variable	074-040	C1106	Selected Value	
C417B	410, Variable	074-040	C1107	13, Variable	075-005
C418	150, 5% 1500V Silver Mica	088-040	C1108	Selected Value	
			C1109	13, Variable	075-005

Capacitors are in Picofarads when listed as a whole number unless otherwise specified. When listed as decimal number, value is in microfarads unless otherwise specified. Resistors are 10% tolerance, 1/2 watt rating, unless otherwise specified.

Ref. Symbol	Description	Part No.
C1110	<i>Selected Value</i>	
C1111	39, Variable	074-056
C1112	12, Variable	074-026 A
C1113	470, 5% 500V Mica	088-032
C1114	430, 2% 500V Mica	088-024
C1115	270, 2% 500V Mica	088-014
C1116	27, 5% 500V Mica	088-023
C1117	430, 2% 500V Mica	088-024
C1118	.01, +80-20% 500V Disc	072-023
C1119	.01, +80-20% 500V Disc	072-023
C1201	.05, +80-20% 100V Disc	072-036
C1202	.001, 20% 500V Disc	072-007
C1203	.05, +80-20% 100V Disc	072-036
C1204	100 mf, 350V Electrolytic	073-046
C1205	100 mf, 350V Electrolytic	073-046
C1206	.1, 200V Molded	085-020
C1207	100 mf, 350V Electrolytic	073-046
C1208	40 mf, 350V Electrolytic	073-040
C1209	150 mf, 150V Electrolytic	073-043
C1210	250 mf, 25V Electrolytic	073-006
C1211	150 mf, 150V Electrolytic	073-043
C1212	150 mf, 150V Electrolytic	073-043
C1213	.0047, 1000V Tubular	085-012
C1214	.0047, 1000V Tubular	085-012
C1215	.01, 1000V Tubular	085-027
C1216	.01, +80-20% 500V Disc	072-023

#### RESISTORS

R101	4.7K	042-472
R102	470K	042-474
R103	100K	042-104
R104	100 Ohm	042-101
R105	56 Ohm	042-560
R106	100K	042-104
R107	4.7K	042-472
R108	10K	042-103
R109	4.7K	042-472
R110	10K 2W	044-103
R201	27K	042-273
R202	10K	042-103
R203	100K	042-104
R204	470K	042-474
R205	10K 2W	044-103
R206	2.7K	042-272
R207	10K	042-103
R208	10K	042-103
R209	10K	042-103
R301	10K	042-103
R302	100K	042-104
R303	100K	042-104
R304	100 Ohm	042-101
R305	22K 1W	043-223
R306	10K	042-103
R307	10K	042-103
R308	10K	042-103

Ref. Symbol	Description	Part No.
R309	22 Ohm 5W	049-045
R401	470K	042-474
R402	1K	042-102
R403	4.7K	042-472
R404	25K Pot	052-038
R405	27K	042-273
R406	27K	042-273
R407	150K	042-154
R408	680 Ohm	042-681
R409	25K Pot	052-038
R410	6K 10W	049-011
R411	6K 10W	049-011
R412	1 Ohm 2W	049-019
R413	470 Ohm	046-471
R414	1000 Ohm	046-102
R415	1 Ohm 2W	049-019
R416	100 Ohm	042-101
R417	100 Ohm	042-101
R601	1K	042-102
R602	47K	042-473
R603	100 Ohm	042-101
R604	470 Ohm	042-471
R605	10K	042-103
R701	10K	042-103
R702	10K Pot	052-042
R703	47K	042-473
R704	27K	042-273
R705	100K	042-104
R706	100K	042-104
R707	27K	042-273
R708	10K	042-103
R709	27K	042-273
R710	10K 1W	043-103
R711	270K	042-274
R712	5K Pot	052-012
R801	2.2 Meg	042-225
R802	47K	042-473
R803	150K	042-154
R804	1K	042-102
R805	22K	042-223
R806	1 Meg Pot	052-013
R807	330K	042-334
R808	330K	042-334
R809	68K	042-683
R810	150K	042-154
R811	270K	042-274
R812	47K	042-473
R901	470K	042-474
R902	2.7K	042-272
R903	1K	042-102
R904	10K	042-103
R905	100K	042-104
R1001	330 Ohm	042-331
R1002	2.2K	042-222
R1003	1.5K	042-152
R1004	100K	042-101

Ref. Symbol	Description	Part No.
R1005	18K	042-183
R1101	1K 5%	046-101
R1102	1K 5%	046-101
R1103	1K 5%	046-101
R1104	470 Ohm 5%	046-471
R1105	2.7K	042-272

Ref. Symbol	Description	Part No.
L302	80 Meter Driver Plate Coil	012-044
L303	40 Meter Driver Plate Coil	012-025
L304	20 Meter Driver Plate Coil	012-094
L305	15 Meter Driver Plate Coil	012-096
L306	10 Meter Driver Plate Coil	012-092
L401	82 uh RFC	027-023

Ref. Symbol	Description	Part No.
<b>RELAYS</b>		
K1	T/R Relay	111-001
K2	Antenna Relay	111-020
<b>TUBES</b>		
V1	12BZ6 VFO Amplifier	472-025
V2	12BE6 Mixer	472-003
V3	6GK6 Driver	472-021
V4	6KD6 Power Amplifier	472-051
V5	6KD6 Power Amplifier	472-051
V6	12BA6 I.F. Amplifier	472-024
V7	6JH8 Balanced Modulator	472-023
V8	12AX7 MIC. Amplifier, A.F. Amplifier	472-009
V9	6FG6 Tuning Eye	472-039
<b>METER</b>		
M1	0-800 M.A.	112-024

