

OPERATION AND MAINTENANCE

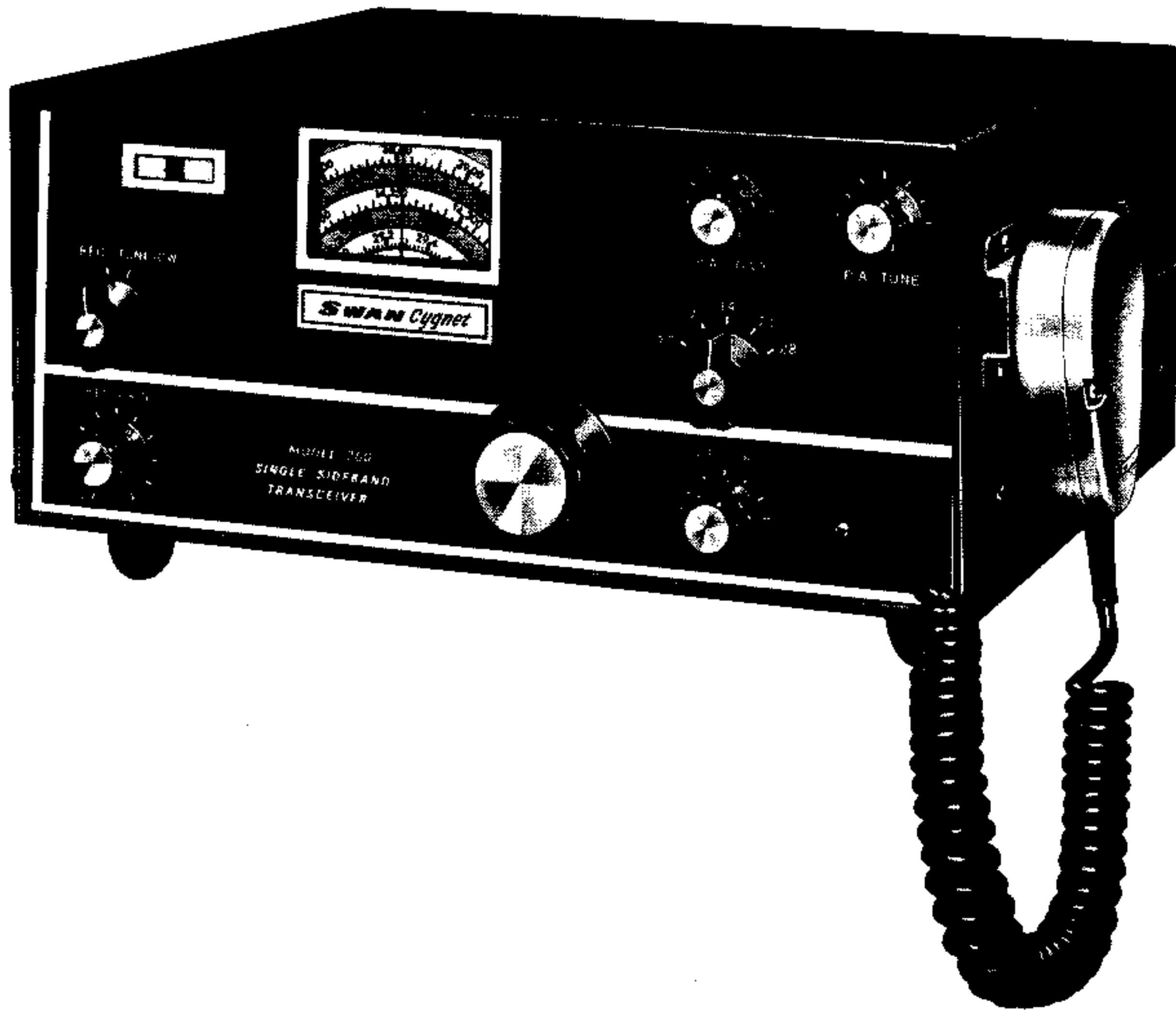

SWAN CYGNET MODEL 260

 **SWAN**
ELECTRONICS
Oceanside, California
A Subsidiary of Cubic Corporation



The Swan Cygnet, Model 260, is an Amateur Radio Single Sideband Suppressed Carrier transceiver. The Cygnet has been carefully designed and manufactured to provide reliable, high quality communications in the 80, 40, 20, 15 and 10 meter amateur bands. It provides for voice communications in the A3J mode (Single Sideband with suppressed carrier) and CW telegraphy A1 mode. The Cygnet is a complete transmitting and receiving system, and it features a built-in power supply for operation from 117 volts ac or 12 volts dc. A 208-220-240 volt ac model is also available. — The loud speaker and microphone are part of

TABLE I: SPECIFICATIONS

FREQUENCY RANGE :

80 Meters	3.5 to 4.0 Mc
40 Meters	7.0 to 7.3 Mc
20 Meters	14.0 to 14.35 Mc
15 Meters	21.0 to 21.45 Mc
10 Meters	28.0 to 29.7 Mc

POWER RATING :

Single Sideband	260 Watts PEP Input
CW Input	180 Watts Input

POWER OUTPUT IN TUNE AND CW MODE

80, 40, and 20	130 Watts average
15 Meters	100 Watts average
10 Meters	75 Watts average

NOTE: PEP output with voice modulation is approximately 30% greater than CW output.

DIAL CALIBRATION :

80, 40, and 20	5 Kc Increments
15 Meters	10 Kc Increments
10 Meters	20 Kc Increments

NORMAL SIDEBAND :

80 and 40 Meters	Lower Sideband
20, 15, and 10	Upper Sideband

CRYSTAL LATTICE FILTER :

Frequency	5500 Kc
Bandwidth	2700 cycles at 6db
	6000 cycles at 50db

AUDIO PASSBAND :

Plus or minus 3db from 300 to 3000 cycles in both transmit and receive.

SIDEBAND SUPPRESSION :

45 db at 1000 cycles

CARRIER SUPPRESSION :

60 db or greater

DISTORTION PRODUCTS :

Approximately 30 db down

PI-NETWORK COUPLER :

50 to 75 ohms for coaxial cable.

CW KEYING :

Grid Block Keying (with offset transmit frequency.)

RECEIVER SENSITIVITY :

0.5 microvolts for signal-plus-noise to noise ratio of 10 db.

DIMENSIONS :

5 1/2 in. high
13 in. wide
11 in. deep

WEIGHT :

24 pounds

TABLE II: CONTROLS AND VACUUM TUBES

<u>FRONT PANEL CONTROLS :</u>		<u>VACUUM TUBE COMPLEMENT :</u>	
REC. GAIN	RF Gain (R1616) and on-off switch (S2)	V1 12BA6	VFO Amp.
REC. TUNE-CW	Switches receive and tune-CW circuits (S4)	V2 12BE6	Trans. Mixer
P. A. TUNE	Pi-Network Tuning (Capacitor C408)	V3 6GK6	Driver
P. A. LOAD	Pi-Network Loading (Capacitor C411)	V4 6LQ6	Power Amp.
Bandswitch	Five Position Band-switch (S1A-E)	V5 6BZ6	Rec. RF Amp.
DRIVER	Driver Tuning (Capacitor C2A-B)	V6 12BE6	Rec. Mixer
Tuning	VFO Tuning (Capacitor C1411)	V7 12BA6	First IF Amp.
		V8 12BA6	Second IF Amp.
		V9 12AX7	Product Det. and Audio Amp.
		V10 6AQ5	A. F. Output
		V11 6JH8	Bal. Modulator
		V12 12BA6	Mic. Amp.
		V13 6FG6	Tuning Eye
		<u>SEMI-CONDUCTORS :</u>	
		Q1 2N706	Oscillator
		Q2 2N706	Buffer
		Q3 2N706	Carrier Oscillator
		Q4 2N1522	D. C. Switching (MHT 1840, Some Models)
		Q5 2N1522	D. C. Switching (MHT 1840, Some Models)
P. A. BIAS	P. A. bias adjustment (Resistor R401)	D1604 through D1612	Silicon Diodes 600 P. I. V., .75 Amp.
ANTENNA	Coax Antenna Connector	D1613 - - - -	1N4742, 1 watt, 12V Zener Diode
Meter	Connection for External Meter	D1301 - - - -	1N34A Germanium Diode
CW Key	Connection for the CW Key or Keyer		
CAR. BAL.	Carrier Balance Control (Resistor R1107)		
Pwr. Switch	Selection for either 117 volts ac or 12 volts dc operation		
Pwr. Conn.	Connection for power cable		

INSTALLATION

GENERAL :

The installation of the Swan Cygnet is not at all difficult and it involves only the placement of the transceiver in its operational area (fixed or mobile), connection of power (either 117 volts AC, or 12 volts DC), and the connec-

~~The following paragraphs are therefore devoted to the~~

installation requirements involving fixed and mobile operation and recommended antenna types. Before actual installation, be sure to check for possible shipment damage. Remove the cabinet, (three screws on each side), and check to make sure that all tubes are firmly in place.

FIXED LOCATION INSTALLATION :

Locate the Cygnet in an area which is well ventilated and which provides complete operational freedom of the front panel controls. Connect the 117 volt power cable to the 5 prong connector on the back. Position the power selector switch to the 117 VAC position. Plug the power cord into an AC outlet which has a capacity of at least 10 amperes. Connect an antenna to the Cygnet which is suitable for the band or bands which are to be used. Refer to the Antenna section of this manual for other information.

P. A. BIAS ADJUSTMENT :

This adjustment has been made at the factory, and will not normally be required when the Cygnet is new. However, it should be checked from time to time, particularly whenever the 6LQ6 P. A. tube is replaced. Also, for 12 volt mobile operation it is recommended that P. A. Bias adjustment be checked.

Nominal cathode idling, or "resting" current for the 6LQ6 is 30 to 40 milliamperes. This is the idling current being conducted by the screen grid and plate circuit of the tube when the transceiver is in transmit mode, but with no R. F. drive to the control grid. Negative bias voltage on the control grid determines what the idling current will be, and it is adjusted with the P. A. Bias control located on the back of the Cygnet. If the idling current is set too low, there will be excessive distortion on the transmitted signal, while if the idling current is set too high, the P. A. tube will dissipate excessive power and thus shorten its life.

A meter jack of the well known "Phono" type will be found on back of the Cygnet.

- (c) Observe the meter reading, and turn the P. A. Bias control for a reading of 1/10 scale. This will be equivalent to 40 Ma.
- (d) Next, check the CAR. BAL. control, also located on back of the Cygnet, to be sure it is adjusted for minimum meter reading. CAR. BAL. must be properly nulled in order to adjust P. A. Bias correctly. If adjusting the CAR. BAL. control for minimum has reduced the idling current to less than 1/10 scale, then re-set the P. A. Bias control.

MOBILE INSTALLATION:

Many different methods of mobile installation are possible, and it is expected that hams will find methods which are best suited for their installation requirements.

Swan Electronics has available a Mobile Mounting Kit which is suitable for under-the-dash installations. Figures 2 and 3 shows the recommended mounting methods using this kit.

A 12 pin Jones connector is supplied with the Cygnet for D. C. operation. This connector has been prewired with two leads; a Red Wire for + 12 to 14 volts D. C., and a Black Wire for Negative Ground. Longer leads are not supplied since the length and wire gauge will vary with different installations. For lead lengths up to about 5 feet, use 10 gauge wire. Splice them to the short wires coming from the Jones connector. Solder and tape well. For lead lengths of 5 to 10 feet use 8 gauge wire.

Important: A 30 ampere fuse should be connected in series with the positive lead. This fuse should be located close to the battery end of the lead. The fuse holder may be either an In-line type, or an insulated block type. This will be available from your dealer.

The mobile antenna will, of course, be a whip type mounted on the rear bumper, rear deck, or front cowl. Swan markets a 5 band mobile antenna known as the Swantenna models 45 and 55. The model 45 is a manually switched system which requires stopping the car to change bands. The model 55 is remotely switched from the drivers location. Other mobile antenna types will also work well with the Cygnet.

ANTENNAS :

A 12 pin Jones connector is supplied with the Cygnet for D. C. operation. This connector has been prewired with two leads; a Red Wire for + 12 to 14 volts D. C., and a Black Wire for Negative Ground. Longer leads are not supplied since the length and wire gauge will vary with different installations. For lead lengths up to about 5 feet, use 10 gauge wire. Splice them to the short wires coming from the Jones connector. Solder and tape well. For lead lengths of 5 to 10 feet use 8 gauge wire.

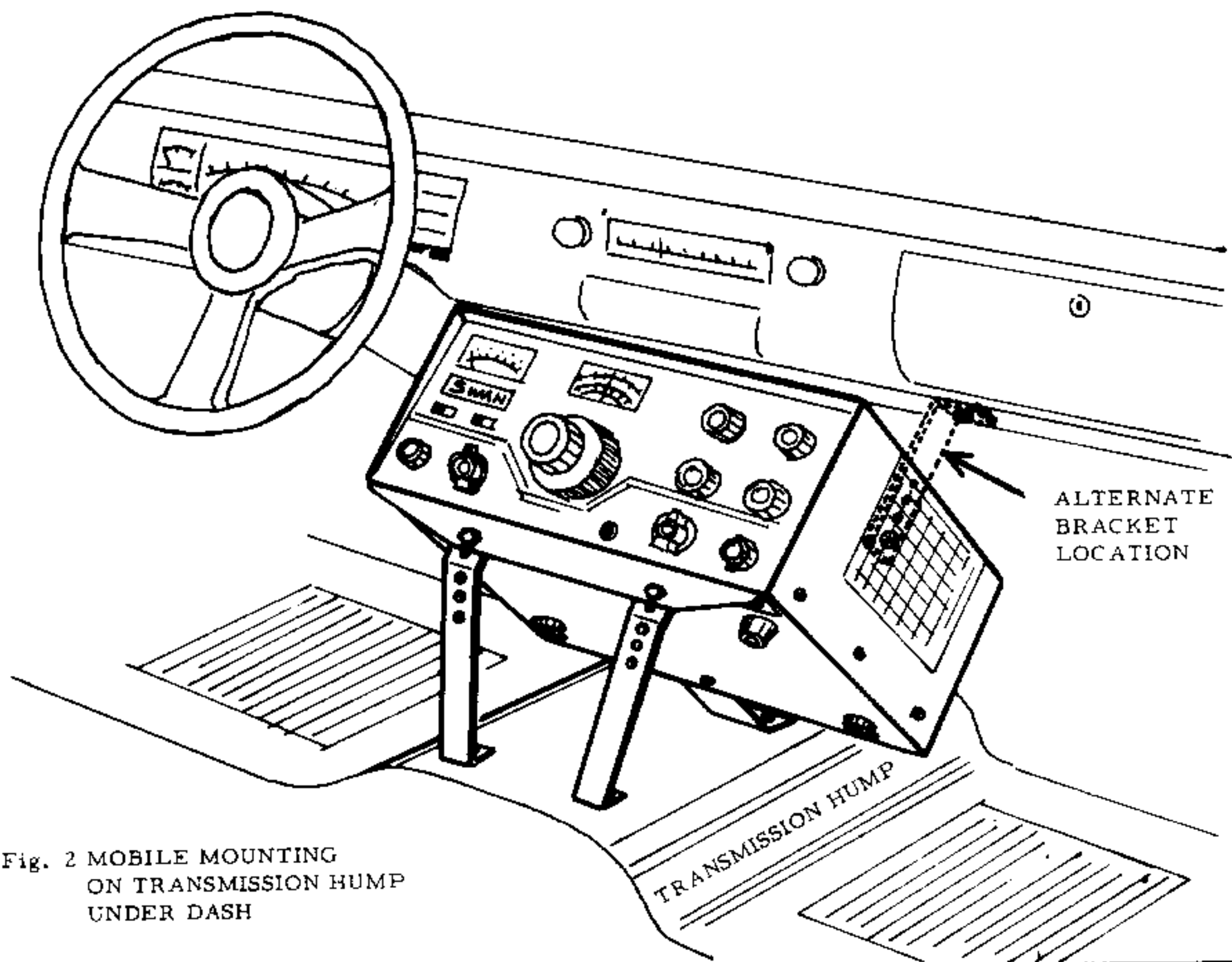
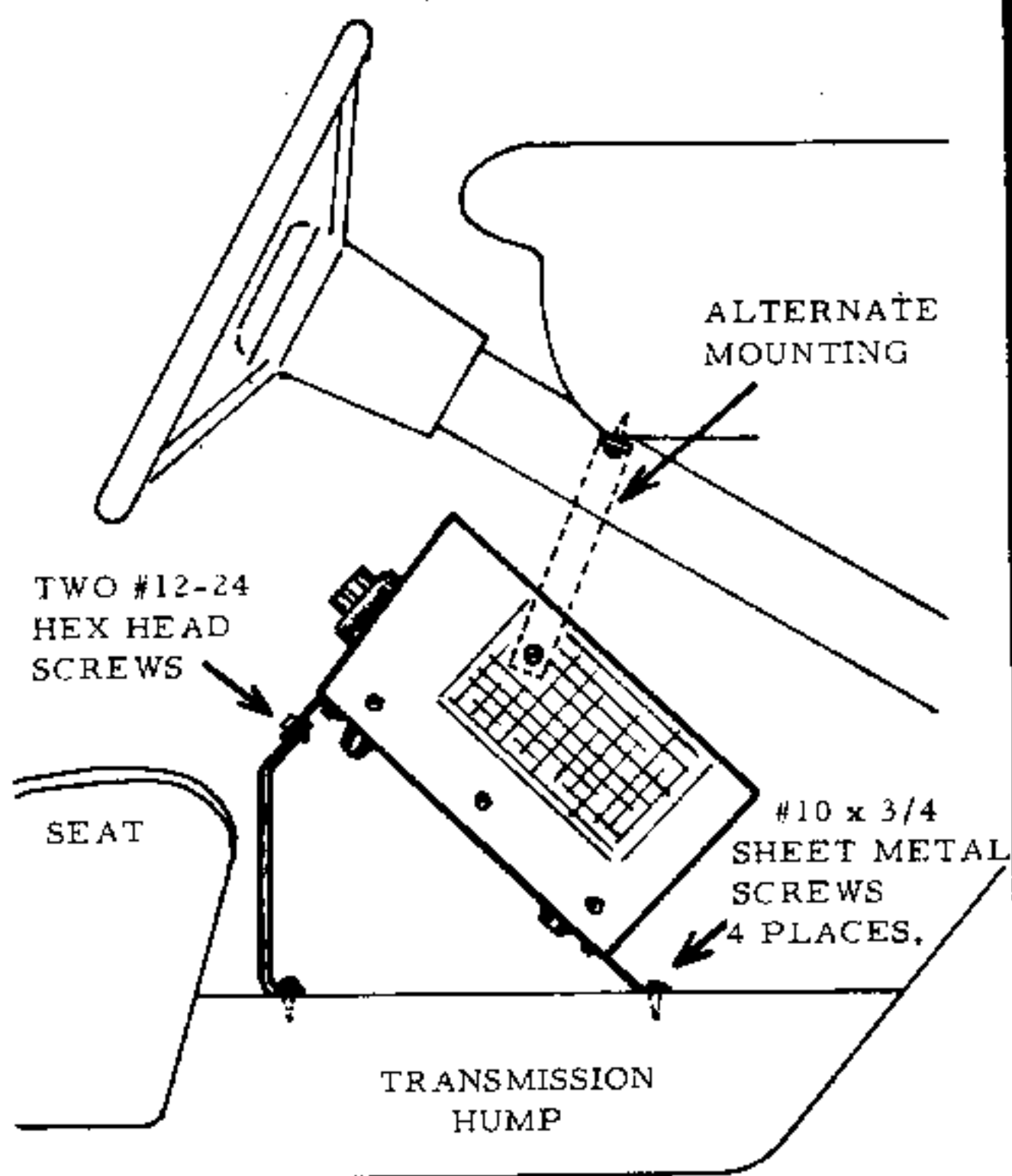
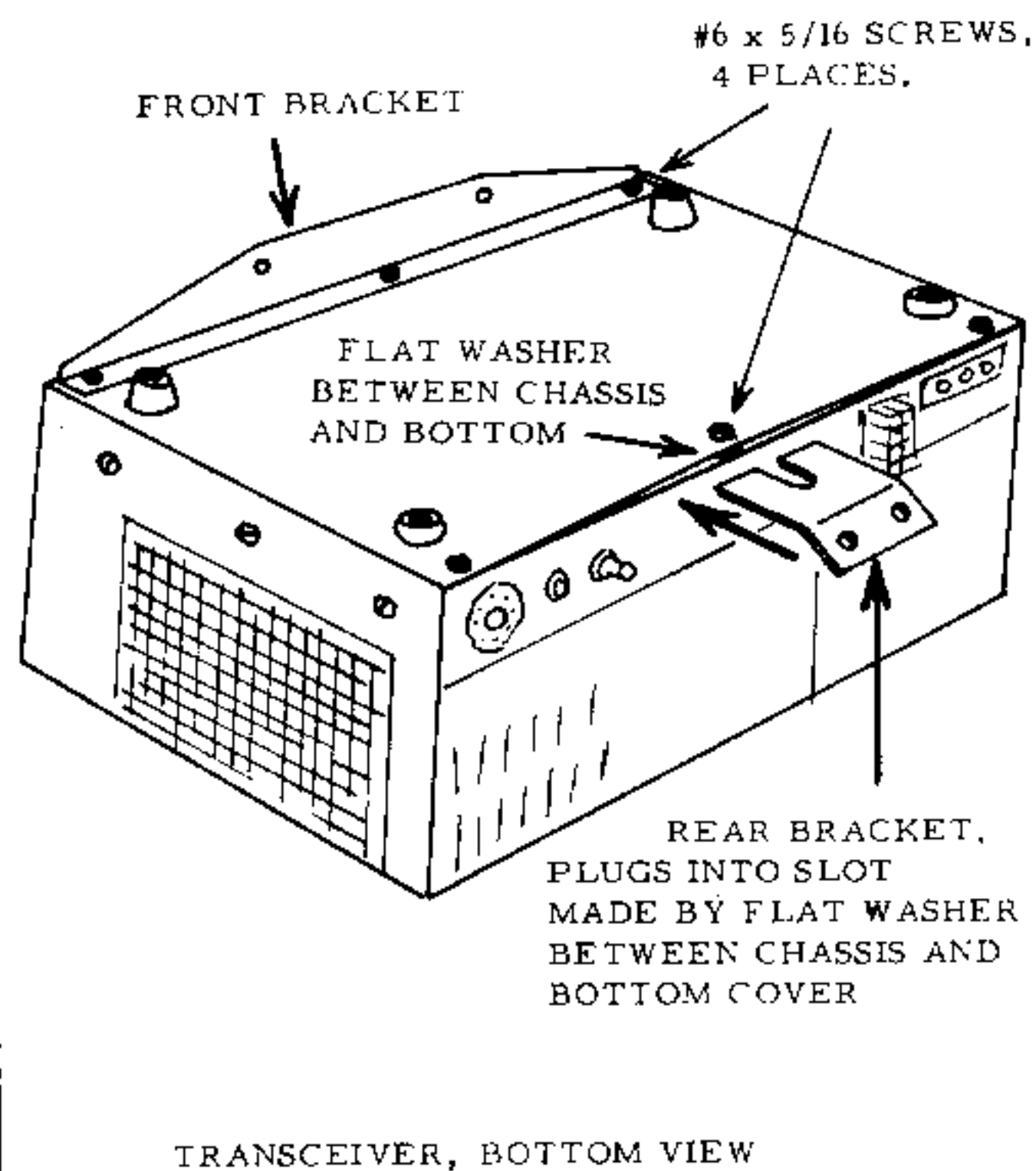

Fig. 2 MOBILE MOUNTING
ON TRANSMISSION HUMP
UNDER DASH



MOBILE MOUNTING, SIDE VIEW



TRANSCEIVER, BOTTOM VIEW

Mobile Antennas:

Mobile antenna installations are quite critical since the antenna represents a number of compromises when used on the high frequency bands. Many amateurs lose the efficiency of their mobile antennas through improper tuning. Points to remember about the mobile antenna are:

- 1) The "Q" of the antenna loading coil should be as high as possible. There are several commercial models available which use high "Q" coils, including the Swan Models 45 and 55 mobile antennas. (Contact your Swan distributor or Swan Electronics for details.)
- 2) The loading coil must be capable of handling the power of the Cygnet without over heating. Wide spaced and heavy gauged wire loading coils are essential.
- 3) The SWR bridge is a useful instrument, but unfortunately it is quite often misunderstood and over rated in importance when working with mobile antennas. Basically, the SWR bridge will indicate how closely the antenna load impedance matches the transmission line. With long transmission lines, such as will be used in many fixed station installations, it is desirable to keep the impedance match fairly close in order to limit power loss caused by SWR on the long transmission line. However, in mobile installations, the transmission line seldom exceeds 20 feet and the loss caused by SWR (even if it approaches 4:1) will be very low. The mobile antenna must be resonated at the desired operating frequency, and the fallacy in using the SWR bridge lies in the fact that the SWR can be reduced by de-tuning the antenna. Since field strength is the primary goal of any antenna system, it is recommended that a Field Strength Meter be used for tuning the antenna to maximum output. Use the SWR reading for what it is worth; do not de-tune the antenna from maximum output in order to reduce SWR.

Antenna Tuners:

As previously stated, the Cygnet is designed to feed energy into un-balanced 50 to 75 ohm coaxial cable. To operate either into a balanced feed line or transmission lines exceeding 75 ohms impedance, an antenna tuner can be used to provide impedance match. Again, refer to one of the many available

RECEIVER TUNING

<u>STEP NO.</u>	<u>CONTROL</u>	<u>OPERATION</u>
(1)	REC. TUNE-CW	Set to "REC." position.
(2)	REC. GAIN	Turn clockwise for Power On, and after warmup, set to desired volume.
(3)	BANDSWITCH	Set to desired Band.
(4)	TUNING KNOB	Set to the desired frequency as indicated by the tuning dial.
(5)	P. A. TUNE, P. A. LOAD and DRIVER	Adjust these controls for maximum signal or background noise.
(6)	TUNING KNOB	Tune for natural sounding voice.

TRANSMITTER TUNING

Be sure to complete step (5), above, before tuning the transmitter. This step places the P. A. controls near their nominal positions. In lieu of step (5), the tuning chart on page 9 may be used.

<u>STEP NO.</u>	<u>CONTROL</u>	<u>OPERATION</u>
(7)	REC. TUNE-CW	Set to "TUNE-CW" position.
(8)	P. A. TUNE, P. A. LOAD and DRIVER	Adjust <u>QUICKLY</u> for maximum closing of the Tuning Eye. <u>Adjust P. A. TUNE First.</u>
(9)	REC. TUNE-CW	Return quickly to REC. position. <u>Do Not hold in TUNE-CW position for more than 20 seconds at a time.</u>

CAUTION : It is most important to observe steps (8) and (9) carefully. The P. A. TUNE control must be resonated immediately when switching to the TUNE mode. Never delay in making this adjustment, since the 6LQ6 P. A. tube can be damaged easily if left out of resonance. P. A. LOAD and DRIVER controls may be adjusted more slowly, but observe the 20 second limit on Tuning.

SINGLE SIDEBAND VOICE OPERATION

(10)	MICROPHONE PUSH-BUTTON	Press the Microphone button, and speak into the microphone. See page 12 for further details.
------	---------------------------	--

CW OPERATION

(11)	KEY JACK, Rear Panel.	Insert CW Key. 1/4 in., 2 circuit plug.
(12)	REC. TUNE-CW	Set to TUNE-CW for Transmission.
(13)	REC. TUNE-CW	Set to REC. for Reception.

FREQUENCY	P. A. TUNE	P. A. LOAD	DRIVER
3.8 mc	2:00 o'clock	2:00 o'clock	12:00
4.0	2:15	1:30	1:00
7.2	1:00	12:00	10:30
14.3	1:30	12:00	11:00
21.4	12:00	11:30	12:00
28.7	2:00	12:00	1:30

Approximate settings of P. A. Controls when transceiver is coupled into a 50 ohm non-reactive load.

OPERATION

GENERAL:

This handbook section provides the recommended tuning and operation procedure for the Cygnet. The information is presented in two ways. First, it is shown in outline form, Table III on page 8, and then with more detail in the following paragraphs.

Before proceeding with operation of the Cygnet, be sure that Installation

Step	Operation and Purpose
------	-----------------------

- (4)..... The large tuning knob controls the frequency of the VFO (and the receive and transmit frequency), and the selected frequency is indicated by the dial. Please note that the dial has separate calibration for each band. The 40 and 15 meter bands are colored green for visual separation. The adjustment of the tuning knob in this step is intended to set the receiver near the desired operating frequency in preparation for the next step (step 5).
- (5)..... The Pi-Network (as adjusted by the P. A. LOAD and P. A. TUNE controls) and the driver stage (as adjusted by the DRIVER control) must be in resonance in order for the receiver to receive maximum signal voltage from the antenna. The controls for the Pi-Network and the Driver must therefore be adjusted for maximum receiver volume.
- (6)..... The large tuning knob is now readjusted for the exact operating frequency as either indicated by the dial or as determined by the received signals. When tuning for a received SSB signal, take the extra care and time to tune the signal in so that it sounds natural. Try to avoid the common tendency of mistuning to a higher than natural pitch. The SSB voice does not normally sound like Donald Duck. Remember that you will not be on exact transmit frequency unless you have tuned the receive signal exactly.

TRANSMITTER TUNING:

This paragraph describes steps 7 through 9 of Table III.

Step	Operation and Purpose
------	-----------------------

- (7)..... The TUNE-CW position of the REC. TUNE-CW switch places the transmitter on-the-air. Since this switch position fully unbalances the Balanced Modulator, the transmitter power amplifier will draw full current. It is for this reason that it is recommended to keep tune-up periods shorter than 20 seconds. If this recommendation is closely followed, maximum usable life of the power amplifier tube will be realized.
- (8)..... Absolute resonance of the Pi-Network and the Driver stage is necessary for maximum transmitter performance. Resonance of these circuits in the transmit mode is indicated by maximum closure of the Tuning Eye. Adjust the P. A. TUNE control immediately when the function switch is turned to "TUNE-CW" position. Do not delay

Step Operation and Purpose

(8).... in resonating this control because the 6LQ6 P. A. tube is drawing full (con't) current and dissipating all of it until the Pi-Network is resonated. Adjust the DRIVER and P. A. LOAD controls next, but learn to do it quickly. It should not require more than a few seconds. Tune only as often as is required. With proper tuning habits the 6LQ6 should provide a year or more of service. Shorter life than this is generally an indication that too much time is spent in tuning up.

NOTE:

During the preceeding paragraphs, all transmitter tuning adjustments were made using the Tuning Eye as an indicator. Provisions have been made in the design of the Cygnet for an external meter. Refer to page 14 for details.

(9).... The REC. TUNE-CW switch must be returned quickly to the REC. position.

NOTE:

It is important to understand that the Pi-Network and the Driver stage must be adjusted for exact resonance only in the transmit mode (either SSB or CW) as described in steps 7 and 8. If the operator is just "listening around," approximate adjustment, as described in steps 4 and 5, is adequate.

TRANSMITTER TUNING WITH A METER

The Cygnet has been provided with a Tuning Eye because this is a very effective and practical way of tuning for maximum output. Also, the tuning eye makes an excellent modulation indicator since it will register voice peaks, whereas the inertia of a standard meter movement will not. However, there are those who may prefer tuning by observing plate or cathode current in the power amplifier stage. This can be done by connecting a meter to the phono jack, as described on page 14. A standard 0-1 Ma. meter with 330 to 390 ohm 1/2 watt resistor connected in series will provide P. A. cathode current readings in the 0-400 Ma. range.

When tuning the transmitter with a meter, the following procedure is recommended:

- a - Set the P. A. LOAD control to 11 o'clock or to the position determined by previous operating.
- b - Switch to TUNE-CW mode, quickly adjust P. A. TUNE for the "dip" in meter reading.
- c - Adjust the DRIVER control for maximum meter reading.
- d - Advance the P. A. LOAD control clockwise, in small steps, each time "dipping" P. A. TUNE again, until a shallow 10 per cent dip in plate current is observed when tuning through resonance. In

other words, if the meter reads about 350 Ma. with P.A. TUNE off resonance, it should dip to about 315 Ma. at resonance. Adjust P.A. LOAD for this condition. We recommend setting the P.A. LOAD control in this manner rather than setting it for some specific meter reading, because the proper loading point varies considerably depending on frequency, tube condition, and supply line voltage. On the lower bands it will not be unusual to see 400 Ma. off resonance, in which case the P.A. LOAD control should be set for a dip to about 360 Ma. But on 10 meters the same set may read only 300 Ma. off resonance, and so the P.A. LOAD should be set for a dip to 270 Ma. in this case.

NOTE: Observe all the preceeding cautions while tuning. Be sure the P.A. TUNE control is quickly resonated except for the very brief moments when off resonance meter readings are observed. Always return to the "dip" very quickly. Also, observe the 20 second limit on tuning periods.

POWER RATING

Generally it will be found that the Cygnet will produce highest meter readings on the lower bands, and lowest on 10 meters. This is a normal condition. With a meter reading of 230 Ma. in Tune mode, the D.C. input will be approximately 180 watts, and P.E.P. input with voice modulation will be approximately 260 watts. This power level will generally be exceeded by a substantial margin on the lower bands, and will usually be met on 10 meters. Remember that tube condition is an important factor, as is voltage level of the power source. In mobile operation, for example, power will be down considerably when the automobile engine is not running, since voltage at the transceiver will be 12 volts or less. With the engine and alternator running, this will rise to about 14 volts, and power will be normal.

SINGLE SIDEBAND VOICE OPERATION

This paragraph describes step 10 of Table III.

Step Operation and Purpose

- (10)... To transmit SSB signals, position the REC. TUNE-CW switch to REC., push the microphone pushbutton and speak into the microphone in a normal tone and loudness of voice. Voice peaks may be observed on the Tuning Eye. Speak just loud enough to produce the same Tuning Eye closure as during tune-up.

MODULATION LEVEL, MIC. GAIN

The Swan Cygnet has been designed for relatively close speaking into the microphone at normal voice level. When operated in this manner, modulation peaks will reach the flat-topping limits of the Power Amplifier. For some operators this may not appear to be quite enough gain. They may be in the habit of speaking more quietly, or further from the microphone. For those who wish to increase

CW OPERATION

This paragraph describes steps 11, 12, and 13 of Table III.

Step Operation and Purpose

(11)... The CW key plugs into the Key Jack provided on the rear panel of the Cygnet. A key which is equipped with a parallel shorting switch may be desirable, since it may then be left plugged into the jack at all times. The switch would then be closed for SSB operation, or for transmitter tuning, and opened for CW transmission. If a Key with shorting switch is not used it will have to be removed from the Key Jack for SSB voice transmission.

(12 & 13) The REC. TUNE-CW switch is used as a "function switch" when operating in the CW mode. Position this switch to TUNE-CW when it is desired to send CW, and REC. to receive.

Note: The Cygnet is designed to provide what is called "Off-Set" frequency during CW transmission. When the function switch is in the TUNE-CW position, the carrier oscillator frequency is shifted upward approximately 800 cycles. Thus, when a CW signal is being received, and the pitch has been adjusted to about 800 cycles, the transmitting frequency will be very nearly the same as the received frequency. This feature helps to avoid the tendency for transceivers to "waltz" one another across the band when they are communicating in the CW mode.

A headphone jack may be installed in the Cygnet, if desired. The closed-circuit jack may be mounted in a 3/8 in. diam. hole on the back of the chassis on the left side, or a number of other places at the owner's discretion. Disconnect the green voice coil lead from the speaker, and wire as illustrated.

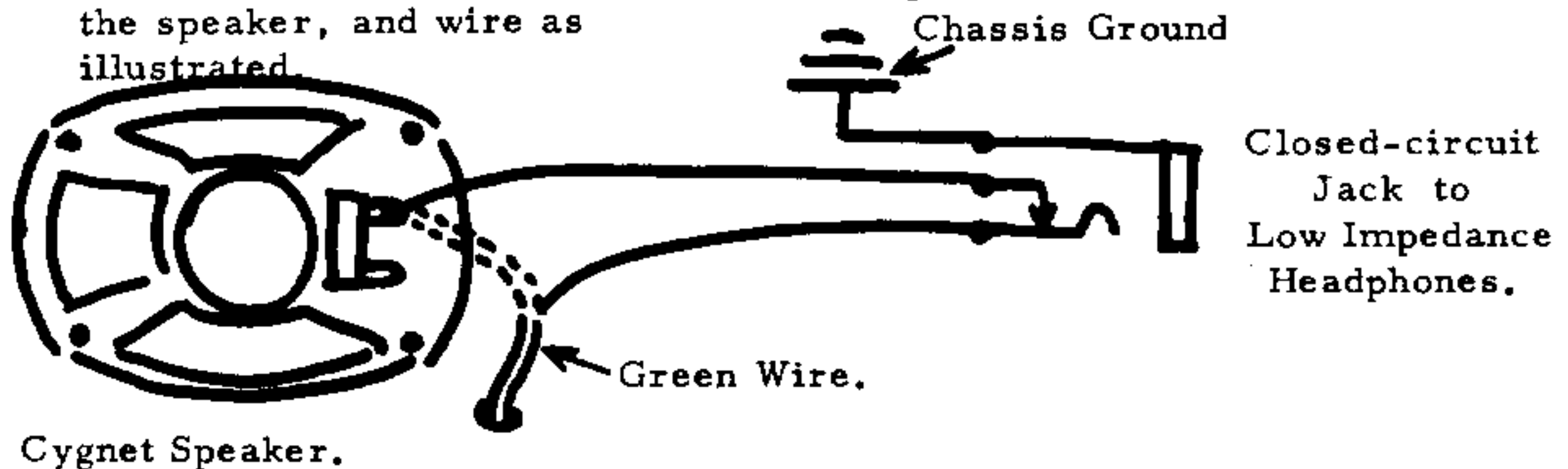

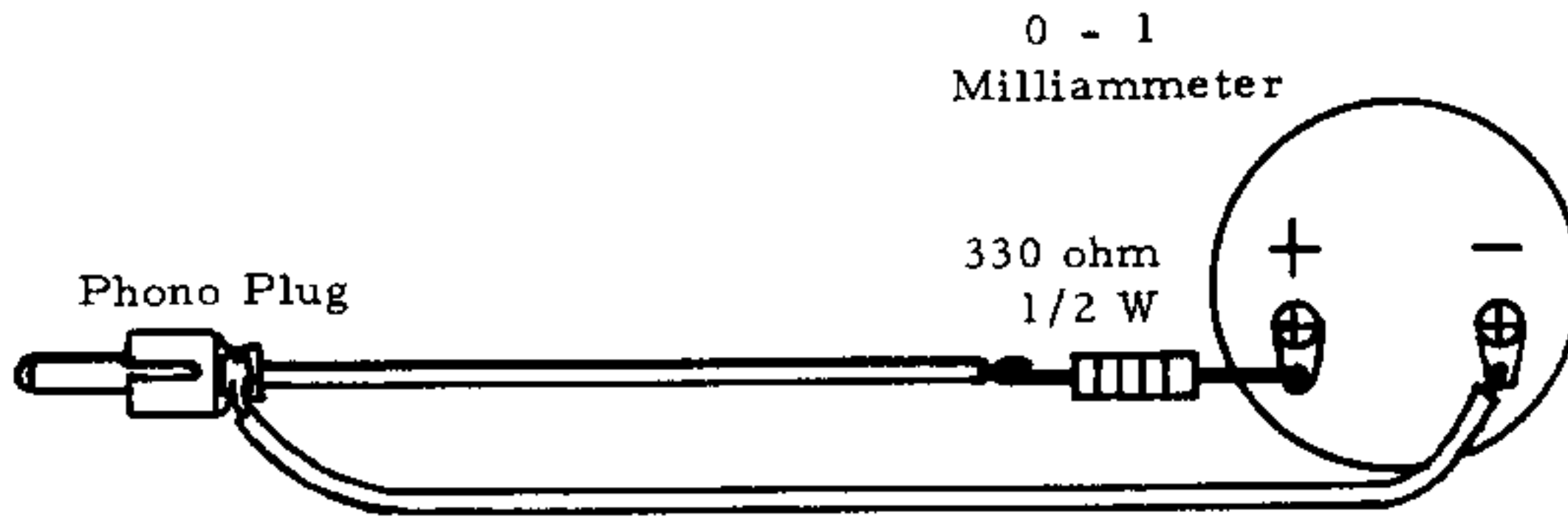

Fig. 4, External Meter Schematic

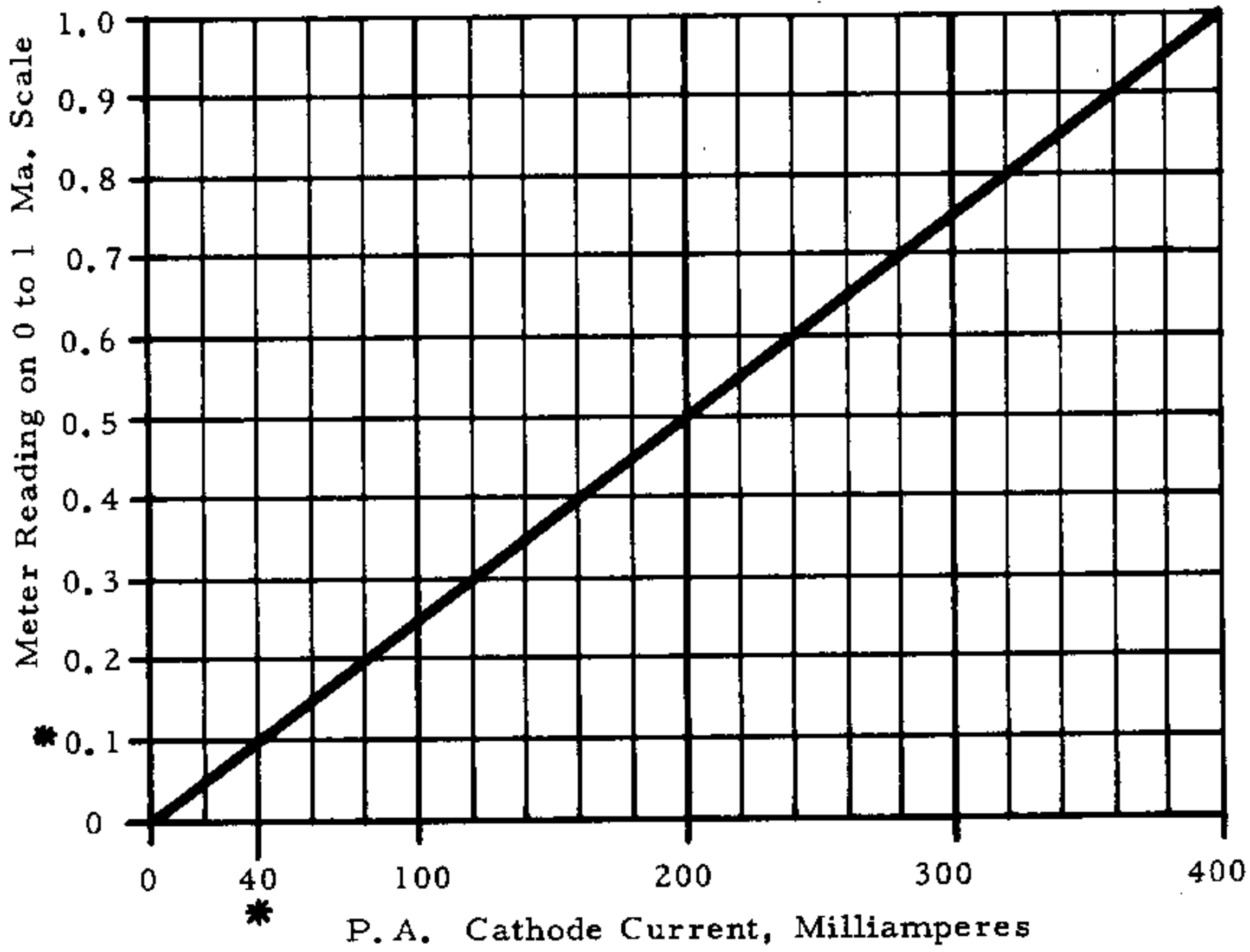

Fig. 5, External Meter, Conversion Chart

*
P.A. Bias
Adjust

CIRCUIT THEORY OF OPERATION

GENERAL:

The development of the single sideband signal with suppressed carrier within the Cygnet is achieved through the use of a balanced modulator and crystal lattice bandpass filter. Other circuits such as the master oscillator, transmitter mixer, transmitter driver and power amplifier, and the product detector provide for transceiver operation. The following paragraphs of this section are a detailed circuit-by-circuit description of the Cygnet.

NOTE :

It is suggested that the schematic diagram (located at the end of this handbook) be folded out for easy view as this section is studied.

TRANSCEIVER SYSTEM:

All circuit functions are integrated into a system which performs the transmit and receive function; this system is known as a transceiver. One of the best known operational advantages of transceiver operation is single control of both transmitter and receiver operating frequencies. In the case of the Cygnet, one operating frequency is established for both transmit and receive frequencies by the V.F.O. The complete transceiver system is shown in block diagram form in Figure 2 (page 10).

TRANSMIT:

When the microphone switch is pushed, the transmitter portion of the transceiver is activated by applying +215 volts dc to the screen grids of the balanced modulator (V11), the power amplifier tube (V4), the transmitter mixer (V2), and the transmitter driver (V3). An SSB signal is developed and transmitted at the desired operating frequency in the following manner:

- a) The balanced modulator (V11), with inputs from the microphone audio amplifier (V12) and the *carrier oscillator (Q3), becomes operational when relay K1 switches to transmit and applies the required +215 volts screen voltage. The microphone audio causes the balanced modulator to become un-balanced by the audio rates which results in a double sideband signal, with suppressed carrier, at the output of the balanced modulator trans-

~~former (T1101)~~ Without-microphone audio, the balanced modulator

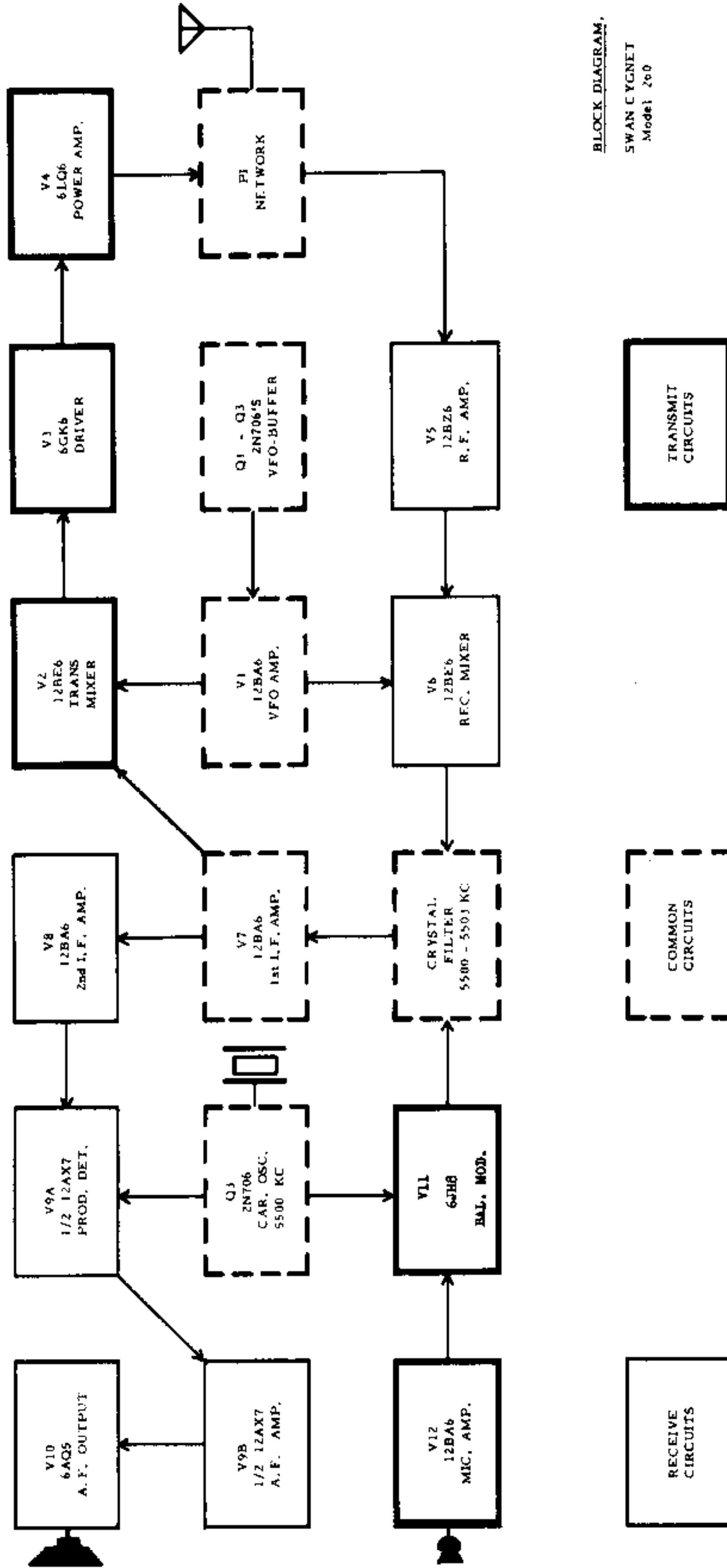

BLOCK DIAGRAM,
SWAN CYGNET
Model 200

Fig. 6 Cygnet Block Diagram

remains balanced and no output will be present. The suppressed carrier will never be completely suppressed, but will appear at the output approximately 60db below the double sidebands.

*NOTE

The carrier oscillator operates at the
~~same frequency as the IF (5500 kc)~~

The balanced modulator is a beam deflection device, and it operates similar to a cathode ray tube in that the electron beam from the cathode is deflected to one output plate or the other by the charge appearing on the deflection plates. The R.F. energy fed to the control grid of the balanced modulator appears on both plates of the output (without signals on the deflection plates), and through push-pull connection and operation of the output transformer, the two R.F. plate signals are cancelled (thus creating suppressed carrier). Adjustable reference voltages are provided for the deflection plates so that the carrier can be nulled. The CAR. BAL. control (R1107) provides this adjustment, and of course, this adjustment is performed when no signals are applied to the deflection plates. The MAINTENANCE section of this handbook provides the proper adjustment procedure for the balanced modulator.

A provision has been provided to un-balance the balanced modulator in order to allow for tuning of the transmitter. This is achieved by grounding one of the deflection plates (pin 1 of V11) through switch S4 (REC. TUNE-CW switch). The TUNE-CW position of switch S4 provides this function. This same switch position also causes the carrier oscillator (Q3) to shift upward in frequency by approximately 800 cycles, and the TUNE-CW position is also used for CW operation.

- b) The double sideband suppressed carrier output from the balanced modulator is connected to the input of the crystal lattice filter. The purpose of the filter is to pass just one of the double sidebands. The output of the crystal filter is therefore a SSB signal. Refer to Figure 3 for the crystal filter's characteristics.

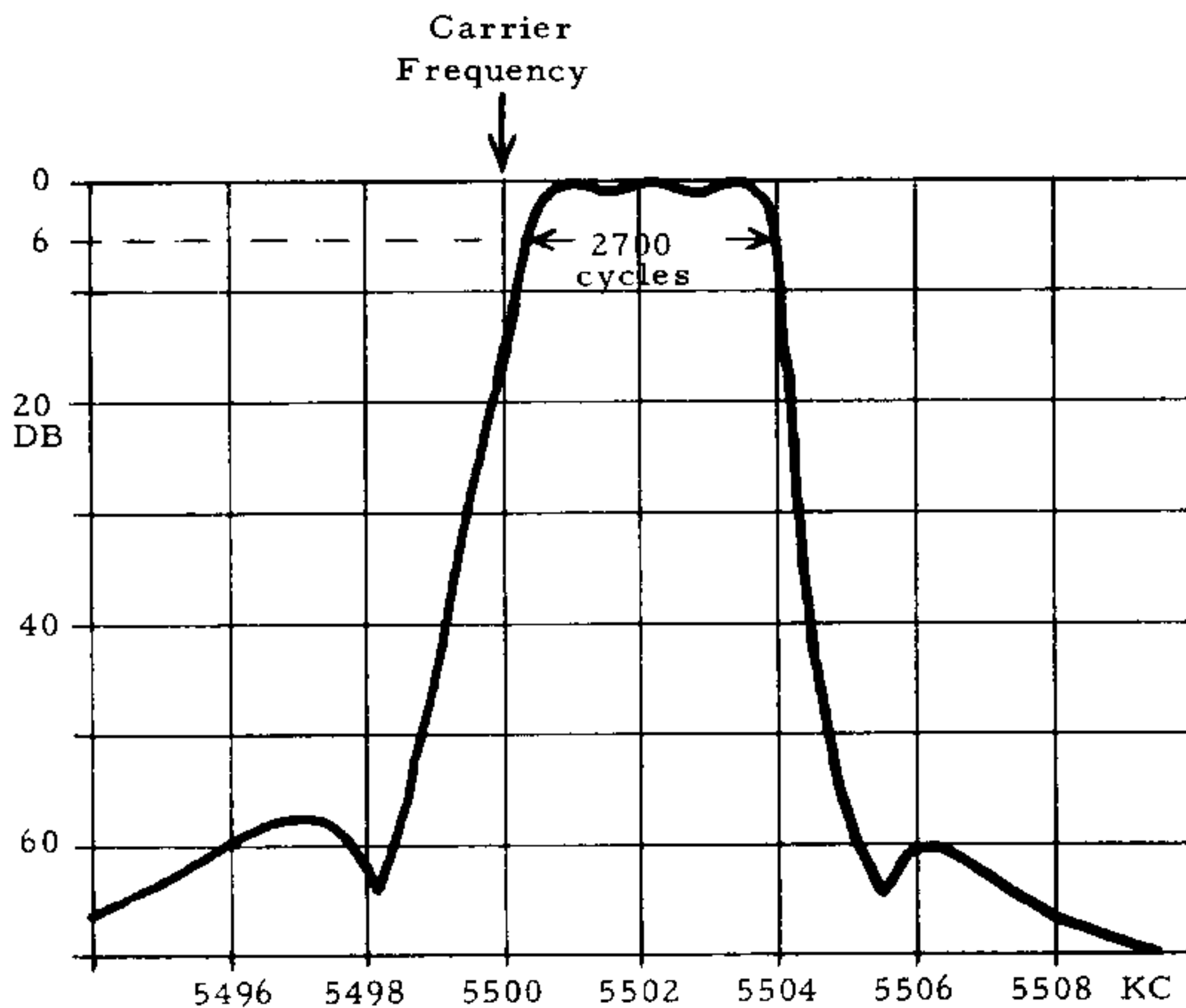

Fig. 7 Crystal Lattice Filter, Nominal Characteristics.

- c) The SSB suppressed carrier signal output from the crystal filter is connected to the transmit mixer stage (V2) after one stage of amplification by the first IF amplifier (V7). Since the SSB signal from the crystal filter is fixed frequency, the IF frequency, the purpose of the transmit mixer is to convert this fixed frequency SSB signal to a desired operating frequency. This is achieved by heterodyning the SSB fixed frequency signal with the output of the VFO. The VFO signal is connected to grid 1 of V2 and the SSB signal is connected to grid 7. Both sum and difference mixing takes place within V2, however, due to the selected VFO *frequencies and the transmit mixer (V2) tuned circuits, only the difference mixed signals are used on 80 and 40 meters (for lower sideband selection) and the sum mixed signals are used on 20, 15 and 10 meters (for upper sideband selection).

*NOTE

See the MAINTENANCE section of this handbook for exact VFO frequencies.

- d) The output of the transmit mixer stage, which is the SSB signal converted to the desired operating frequency, is amplified by the driver stage (V3) followed by the power amplifier stage (V4). These amplifiers are operating class AB and are considered to be linear amplifiers. The output of the power amplifier stage is connected to the antenna through the Pi-Network.

RECEIVE:

The receiver portion of the transceiver is a superheterodyne receiver and it is activated by applying proper screen voltage to the receiver R. F. amplifier (V5), the receiver mixer (V6), and the second I. F. amplifier (V8) and +215 volts dc to the product detector (V9A) and receiver audio (V9B). A SSB signal is received and demodulated in the following manner:

- a) The received SSB signal is converted to the intermediate frequency, after one stage of R. F. amplification, (V5), in the receiver mixer stage (V6). Electron coupling is used within the mixer tube, and the local oscillator input to the mixer is the same signal used by the transmit mixer stage (V2).
- b) The intermediate frequency output of the mixer stage is passed through the same crystal lattice filter used by the transmitter portion of the transceiver, and it is important to note that the intermediate frequency is the same as that used by the transmitter. The filter passes only the sideband to be received (lower for 80 and 40 meters and upper for 20, 15 and 10 meters), and the filter will attenuate strong signals which are on adjacent frequencies. Following the output of the crystal filter, the intermediate frequency SSB signals are amplified by the first and second I. F. amplifiers (V7 and V8).
- c) The intermediate frequency SSB signal is demodulated by the product detector stage (V9A). This stage is essentially a mixer of the electron coupled type. The intermediate frequency SSB signal is mixed with the carrier oscillator (from Q3) and the resultant output, as with all mixers, contains a sum and difference frequency of the two inputs. In the case of the product detector, however, the difference frequency is an audio frequency (the audio component of the SSB signal) and the sum frequency is a radio frequency. Audio detection is achieved by shunting the radio frequency signal to ground with shunt capacitor C901 at the output of the product detector and passing the audio frequencies to the next stage of audio amplification (V9B) through an audio RC network (R904 and C902).

- d) The REC. GAIN control provides control of the input R. F. signal and the I. F. amplifiers through the common bias line to tubes V5, V6 and V8.

TRANSMIT AND RECEIVE SWITCHING:

All transmit and receive switching is performed by relay K1. This relay provides the required switching for the +215R and +215T voltage lines and the antenna connection to the input of the receiver.

POWER SUPPLY SYSTEM :

The power supply for the Cygnet is self contained, and is designed to operate with either 117 volts, 50 to 60 cycle AC, or 12 to 14 volts D.C. The Cygnet Export Model operates with 208, 220, or 240 volts, 50 to 60 cycles, as well as 12 to 14 volts D.C. Connection to the power source is via a power cable and connector assembly. One cable assembly is required for AC operation, and another for DC.

When using the Cygnet with a power source connected directly to the

primary of transformer T1602, and when using dc power, power is connected directly to the input of a solid state dc chopper. In both cases, however, the proper power cable must be used and the power selection switch on the rear panel must be properly positioned. The rectifier

MAINTENANCE

GENERAL:

This handbook section provides information for troubleshooting and routine alignment of the transmitter and receiver circuits. This information is prepared specifically for the owner at home. If a greater degree of information is required, either by the owner at home or a professional service center, contact the Customer Service Department at Swan Electronics, Oceanside, California.

All circuits in the Cygnet transceiver are conservatively designed to provide many trouble-free operating hours. Most problems encountered with the transceiver will be the result of vacuum tube failure or abuse. These problems can usually be corrected by replacing tubes and/or performing the routine alignment procedures contained in the following paragraphs.

In the event that tube replacement or alignment does not correct an encountered problem, the troubleshooting information contained in the following paragraphs will be useful.

WARNING

DANGEROUS HIGH VOLTAGE IS PRESENT ON THE PLATE OF THE POWER AMPLIFIER WHENEVER THE POWER SUPPLY IS TURNED ON. EXERCISE EXTREME CARE WHEN PERFORMING TROUBLESHOOTING AND ALIGNMENT PROCEDURES.

TROUBLESHOOTING:

The information contained in Figures 8 and 9, Tables IV and V, and the schematic drawing (at the end of this handbook) should be sufficient for most troubleshooting needs by the average licensed amateur radio operator.

TABLE IV VFO AND CARRIER OSCILLATOR FREQUENCIES

Tuning Dial	V1 Injection Frequency	Q1 Osc. Frequency	Q3 Osc. Carrier Frequency
3500 KC	9000 KC	9000 KC	5500 KC
4000 KC	9500 KC	9500 KC	5500 KC
7000 KC	12,500 KC	(1/2) 6250 KC	5500 KC
7300 KC	12,800 KC	(1/2) 6400 KC	5500 KC
14,000 KC	8500 KC	8500 KC	5500 KC
14,350 KC	8850 KC	8850 KC	5500 KC
21,000 KC	15,500 KC	(1/2) 7750 KC	5500 KC
21,450 KC	15,950 KC	(1/2) 7975 KC	5500 KC
28,000 KC	22,500 KC	(1/2) 11,250 KC	5500 KC
29,700 KC	24,200 KC	(1/2) 12,100 KC	5500 KC

TABLE V VOLTAGE AND RESISTANCE CHART

TUBE TYPE	R = Rec. T = Trans.	Socket Pin Numbers								
		1	2	3	4	5	6	7	8	9
V1 12BA6 VFO Amp.	R Volts	-.6	∅	∅	12.6 AC	45	45	∅	-	-
	T Volts	-.6	∅	∅	12.6 AC	50	50	∅	-	-
	Ohms	1.2 K	∅	∅	0.2	*	*	∅	-	-
V2 12BE6 Trans. Mixer	R Volts	-1.2	∅	∅	12.6 AC	250	-2	∅	-	-
	T Volts	-1.0	∅	∅	12.6 AC	250	135	∅	-	-
	Ohms	100 K	∅	∅	0.2	*	11 K	35 K	-	-
V3 6GK6 Driver	R Volts	∅	-6.7	∅	∅	6.3 AC	NC	255	0	∅
	T Volts	∅	-6.7	∅	∅	6.3 AC	NC	265	225	∅
	Ohms	10	100 K	∅	∅	0.3	NC	*	0.2	∅
V4 6LQ6 Pwr. Amp.	R Volts	NC	-75	∅	12.6 AC	6.3 AC	-75	∅	∅	NC
	T Volts	NC	-75	∅	12.6 AC	6.3 AC	-75	225	∅	NC
	Ohms	NC	6 K	1.0	0.1	0.3	6 K	0.1	∅	NC
V5 6BZ6 Rec. R. F.	R Volts	∅	∅	6.3 AC	∅	255	115	∅	-	-
	T Volts	∅	∅	6.3 AC	∅	255	∅	∅	-	-
	Ohms	1.1 M	∅	0.1	∅	14 K	40 K	∅	-	-
V6 12BE6 Rec. Mixer	R Volts	∅	∅	∅	12.6 AC	250	100	-0.5	-	-
	T Volts	∅	∅	∅	12.6 AC	265	∅	-0.5	-	-
	Ohms	100 K	∅	∅	0.1	11 K	40 K	45 K	-	-
V7 12BA6 1st I. F.	R Volts	-1.8	∅	∅	12.6 AC	210	48	∅	-	-
	T Volts	-1.8	∅	∅	12.6 AC	220	50	∅	-	-
	Ohms	500	∅	∅	0.1	15 K	50 K	∅	-	-
V8 12BA6 2nd I. F.	R Volts	-1.7	∅	∅	12.6 AC	205	105	∅	-	-
	T Volts	-1.7	∅	∅	12.6 AC	225	∅	∅	-	-
	Ohms	110 K	∅	∅	0.1	15 K	40 K	∅	-	-
V9 12AX7 Det. A. F.	R Volts	55	-1	∅	∅	∅	145	-0.25	∅	6.3 AC
	T Volts	-3	-1.6	∅	∅	∅	∅	-0.25	∅	6.3 AC
	Ohms	400 K	11 K	300	∅	∅	125 K	1 M	∅	0.2
V10 6AQ5 A. F. Output	R Volts	-9	∅	∅	6.3 AC	237	215	NC	-	-
	T Volts	-9	∅	∅	6.3 AC	262	∅	NC	-	-
	Ohms	500 K	∅	∅	0.2	10 K	12 K	NC	-	-
V11 6JH8 Bal. Mod.	R Volts	∅	∅	∅	6.3 AC	∅	-1.4	∅	∅	∅
	T Volts	45	45	75	6.3 AC	∅	-1.4	∅	100	100
	Ohms	2 K	75 K	500 K	0.2	∅	35 K	∅	75 K	75 K
V12 12BA6 Mic. Amp.	R Volts	-0.75	∅	∅	12.6 AC	∅	∅	∅	-	-
	T Volts	-0.75	∅	∅	12.6 AC	85	20	∅	-	-
	Ohms	1 M	∅	∅	0.1	150 K	600 K	∅	-	-

NOTE: (1) Voltage Measurements made with 20,000 ohm per volt meter, or with VTVM.

(2) Voltage figures are D.C. unless otherwise specified.

(3) REC. GAIN full on, clockwise.

4. ~~Transmittance~~ Measurements made by pressing Mic. Button. Carrier



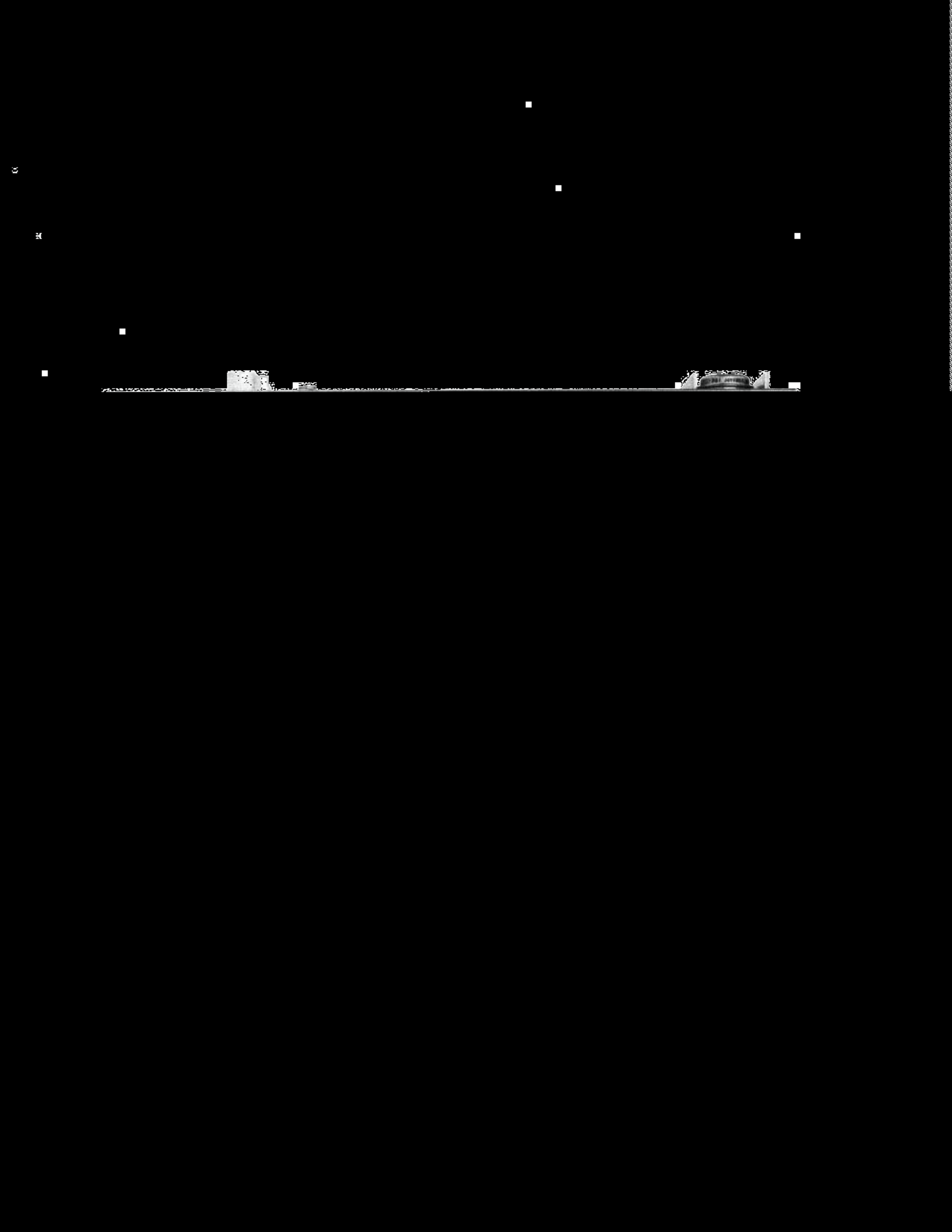

TABLE VI TROUBLESHOOTING CHART

DEFECT	POSSIBLE CAUSE
PA IDLING CURRENT UNSTABLE	<ol style="list-style-type: none"> 1. Defective Power Amplifier Tube (V4). 2. Defective BIAS control and/or associate components. 3. Defective bias power supply.
INABILITY TO LOAD PER OPERATION INSTRUCTIONS	<ol style="list-style-type: none"> 1. Antenna not resonant at operating frequency. 2. Defective transmission line. 3. Defective antenna loading coil (s). 4. Tubes V1 through V4 defective.
INSUFFICIENT SIDEBAND SUPPRESSION	<ol style="list-style-type: none"> 1. Carrier Oscillator (Q3) operating on incorrect frequency. 2. Crystal filter defective or mistuned.
INSUFFICIENT CARRIER SUPPRESSION	<ol style="list-style-type: none"> 1. Tube V11 defective. 2. Transformer T1101 defective or mistuned. 3. Carrier Oscillator (Q3) operating on incorrect frequency.
MICROPHONICS IN TRANSMITTER	<ol style="list-style-type: none"> 1. Tubes V11 and/or V12 defective. 2. IF transformer L701 defective or incorrectly adjusted. 3. Microphone defective.
LOW RECEIVER SENSITIVITY	<ol style="list-style-type: none"> 1. Tubes V5 through V10 defective. 2. Incorrect adjustment of the transmitter Pi-Network. 3. IF transformer L801 incorrectly adjusted or defective. 4. K1 relay contacts defective.

TRANSCEIVER ALIGNMENT PROCEDURES:

The alignment procedures presented in this section are routine touch-up procedures for all tuned circuits and other adjustments. It is recommended that the procedures be performed in the order presented. However, if complete re-alignment is not required (as may be the case when just one tube is replaced), perform just those procedures required.

Before starting these alignment procedures, it is important to note that external metering for the measurement of power amplifier current will be required. Refer to pages 14 and 15 for a description of the external metering circuits provided within the Cygnet.

Receiver Alignment:

Receiver alignment involves only the adjustment of the First and Second IF coils. The R.F. coils which affect receiver performance are also used in transmit mode. Their adjustment is covered under "Transmitter Alignment" on the following page. Note that the adjustment of the crystal filter coil L602 is considered a factory or service center adjustment due to the complexity of test set-up. DO NOT ADJUST COIL L602 unless you have the required test equipment and the recommended procedure from Swan Electronics.

- 1) After allowing approximately five minutes for warm-up tune the receiver to the middle of any band and at a "clear" frequency.
- 2) Adjust the P. A. TUNE, P. A. LOAD, and DRIVER front panel controls for maximum background noise.
- 3) Adjust IF coils L701 and L801 for maximum background noise. Repeat the adjustments several times.

Transmitter Power Amplifier Bias:

- 1) Connect an external meter to the METER connector on the rear panel. (See page 14 for metering details.)
- 2) After allowing approximately five minutes for warm-up, key the transmitter with the microphone switch. Without speaking into the microphone, adjust the CAR. BAL. control on the rear panel for a minimum power amplifier current.
- 3) Again key the transmitter with the microphone switch, and without speaking into the microphone, adjust the P. A. BIAS control on the rear panel for a power amplifier current of 30 to 40 MA.

Transmitter Alignment:

The alignment of transmitter circuits involve the adjustment of tuned circuits in the VFO Amplifier, V1, the Transmit Mixer, V2, and Driver stage, V3. It is recommended that a dummy load be connected to the antenna jack during this series of adjustments.

TUNING CHART:

Band	Tuning Dial	Driver Control Setting	VFO Amp. Coil	Mixer Coil	Driver Coil
3.5 mc	3800	12 o'clock	No adjustment	L201	L301
7 mc (start)	7200	10:30 o'clock	L103	L202 (top core)	L302 (bottom core)
14	14,250	11 o'clock	No adjustment	L203 (bottom core)	L303 (top core)
21	21,300	12 o'clock	L101 (top core)	L204 (top core)	L304 (bottom core)
28	28,700	1:30 o'clock	L102 (bottom core)	L205 (bottom core)	L305 (top core)
*Optional 28,400		o'clock	L102	L205	L305
*Optional 29,200		o'clock	L102	L205	L305

*NOTE: The 28 mc band should be peaked in the normally used portion of the band, as indicated by the optional frequencies. Power output will drop off somewhat when operating more than 500 KC away from the frequency at which the coils are peaked.

Order of procedure:

- (1) Start first by adjusting 7 mc band. Set tuning Dial and Driver control as indicated by Tuning Chart.
- (2) Insert test meter in phono type jack provided on back of set. (0-1 Ma. movement with 330-390 ohm series resistor as described on page 14.) Set P.A. LOAD control to 11 o'clock.

- (3) Press Mic. Button. Check idling current. It should be between 30 and 40 ma. when "Car. Bal." control is nulled. Adjust "P. A. Bias" control, if required.
- (4) With Mic. Button pressed, adjust "Car. Bal." control for slight increase in meter reading, 50 to 60 ma. Adjust P. A. Tune to resonance, (dip).
- (5) Adjust coils as indicated by chart for maximum meter reading. When reading goes higher than 80 ma., or so, adjust "Car. Bal." for 60 ma. again.
- (6) Adjust coils carefully for maximum peak. Exercise caution with "Car. Bal." control. Do not exceed 100 ma. reading for more than a few seconds. Be sure "P. A. Tune" control is resonated, (adjusted for "dip" in meter reading).
- (7) Switch to 3.5 mc band, and repeat steps (1) through (6), following the tuning chart carefully. Follow this procedure through for each of the other bands.

Power Amplifier Neutralization:

Perform the power amplifier neutralization adjustment on 20 meters and in the following manner.

- (1) After allowing approximately two minutes for warm-up, tune the transmitter to approximately 14,250 mc as described in the OPERATION section of this handbook.
- (2) Position the "P. A. LOAD" front panel control to the 9 o'clock position.
- (3) Connect an external meter to the METER connector on the rear panel (see pages 14 and 15 for metering details).
- (4) Key the transmitter with the microphone switch, and without speaking into the microphone, adjust the "CAR. BAL." control on the rear panel for a power amplifier current of approximately 100 Ma. Adjust the "DRIVER" control for peak. Quickly adjust "CAR. BAL." to 100 Ma. again if it increased to a higher reading.
- (5) With the Mic. Button still pressed, rotate the P. A. TUNE control through its range from 9 o'clock to 3 o'clock. You will note a pronounced "dip" in meter reading at resonance. Observe any tendency for the meter to "peak" above the 100 Ma. plateau on

either side of resonance. If there is such a peak, adjust C402, the P.A. Neutralizing trimmer to suppress the peak. When properly neutralized, the meter reading will hold steadily at 100 Ma. except for the sharp dip at resonance, but there will be no peak above the 100 Ma. level.

- (6) Key the transmitter with the microphone switch and re-adjust the CAR. BAL. control for minimum power amplifier current. Minimum power amplifier current should be between 30 and 40 Ma. If not, repeat the transmitter power amplifier bias adjustment on page

Carrier Balance Adjustment:

Several times during the preceding adjustments, the CAR. BAL. rear panel control has been adjusted for varying reasons. Be sure that this control is adjusted for exact null before operating.

VFO Calibration:

A trimmer capacitor is provided for each VFO range. These adjustment capacitors are available through the top of the VFO compartment. It is recommended that an insulated adjusting tool be used when performing the following adjustments.

NOTE

Dial tracking has been factory set by

PARTS LIST

RESISTORS All resistors are 1/2 watt 10% tolerance, unless otherwise noted.

R101	1K	R1202	47K
R102	2.7K	R1203	100K
R103	2.7K	R1204	1M
R201	27K	R1205	10M
R202	100K	R1206	47K
R203	10K - 2W	R1301	470K
R204	470K	R1302	1K
R205	2.7K - 1W	R1303	100K
R301	270K	R1401	1K
R302	100K	R1402	1.5K
R303	10	R1403	1K
R401	5K - Variable	R1404	470
R402	10K - 1W	R1405	2.7K
R403	1K	R1406	2.7K
R404	1 ohm - 2W	R1407	470
R501	1M	R1501	2.2K
R502	100K	R1502	18K
R503	47K	R1503	1.5K
R601	100K	R1504	100
R701	470	R1601	0.27 - 5W
R702	4.7K	R1602	0.5 - 5W
R703	18K - 2W	R1603	0.5 - 5W
R704	1K	R1604	0.27 - 5W
R801	100K	R1605	350 - 5W
R802	1K	R1606	4.7
R901	10K	R1607	150K - 2W
R902	270	R1608	150K - 2W
R903	270K	R1609	800 - 10W
R904	270K	R1610	1.5K - 2W (or 1.2K)
R905	10M	R1611	2.7K
R906	1M	R1612	900 - 10W
R907	47K	R1613	800 - 10W
R908	100K	R1614	10K - 2W
R1001	470K	R1615	10K
R1101	1K	R1616	10K - Variable
R1102	47K	R1617	470
R1103	47K	R1618	100K
R1104	470K		
R1105	27K		
R1106	47K (100K optional)		
R1107	5K - Variable		
R1108	47K		
R1201	470K		

CAPACITORS

Unless otherwise specified, a capacitor is listed in pico farads with a whole number and in micro farads with a decimal number.

C2 A/B	85-Variable	C702	.01-Ceramic
C101	.01-Ceramic	C703	50-Ceramic
C102	27-N150 Ceramic	C704	.01-Ceramic
C103	39-NPO Ceramic	C801	.01-Ceramic
C104	100-Ceramic	C802	.01-Ceramic
C105	100-Ceramic	C803	50-Ceramic
C106	.002-Ceramic	C804	50-Ceramic
C201	.01-Ceramic	C805	.01-Ceramic
C202	68-Mica	C901	220-Ceramic
C203	.01-Ceramic	C902	.002-Ceramic
C204	470-Mica	C903	150-Ceramic
C205	2 Ceramic	C904	2MF-450WV Electrolytic
C206	.002-Ceramic	C905	.001-Ceramic
C207	50-N750 Ceramic	C1001	.002-Ceramic
C301	.002-Ceramic	C1002	.0047-Mylar-1000V
C302	68-Mica	C1101	.01-Ceramic
C303	50-N750 Ceramic	C1102	.01-Ceramic
C304	510-Mica	C1103	.01-Ceramic
C305	15-N750 Ceramic	C1104	220-Ceramic
C306	.002-Ceramic	C1105	.002-Ceramic
C401	15-N750 Ceramic	C1201	.01-Ceramic
C402	80-Mica Trimmer	C1202	.1-Mylar-400V
C403	.002-Ceramic	C1203	.1-Mylar-400V
C404	.01-Ceramic	C1204	100-Ceramic
C405	.01-Ceramic	C1205	.01-Ceramic
C406	.002-Ceramic	C1301	.002-Ceramic
C407	270-Mica	C1401	10 Selected
C408	180-Variable	C1402	5- Trimmer
C409	100-6KV Ceramic	C1403	72 Selected
C410	330-Mica	C1404	10- Trimmer
C411	820-Variable	C1405	44 Selected
C501	.01-Ceramic	C1406	15- Trimmer
C502	30-Ceramic	C1407	127 Selected
C601	10-Ceramic	C1408	15- Trimmer
C602	.01-Ceramic	C1409	35 Selected
C603	220-Ceramic	C1410	15- Trimmer
C604	5-Ceramic	C1411	20-Variable
C605	5-Ceramic	C1412	22-Ceramic
C606	30-Ceramic	C1413	470-Mica
C607	430-Ceramic	C1414	270-Mica
C701	50-Ceramic	C1415	430-Mica
		C1416	27-Mica

CAPACITORS (continued)

C1417	.01-Ceramic
C1418	.01-Ceramic
C1419	430-Ceramic
C1501	10-Ceramic
C1502	20-Trimmer
C1503	270-Ceramic
C1504	270-Ceramic
C1505	.01-Ceramic
C1601	250MF-25V Electrolytic
C1602	100MF-35V Electrolytic
C1603	.0047-1400VDC Ceramic
C1604	.0047-1400VDC Ceramic
C1605	250MF-25V Electrolytic
C1606	100MF-35V Electrolytic
C1607	2MF-450V Electrolytic
C1608	40MF-350V Electrolytic
C1609	40MF-350V Electrolytic
C1610	80MF-150V Electrolytic
C1611A/B	40-40MF-450V Electrolytic
C1612	10MF-150V Electrolytic
C1613	10MF-150V Electrolytic
C1614	5MF-50V Electrolytic

COILS

L101	VFO Amp. -15M
L102	VFO Amp. -10M
L103	VFO Amp. -40M
L201	Mixer-80M
L202	Mixer-40M (top)
L203	Mixer-20M (bottom)
L204	Mixer-15M (top)
L205	Mixer-10M (bottom)
L301	Driver-80M
L302	Driver-40M (bottom)
L303	Driver-20M (top)
L304	Driver-15M (bottom)
L305	Driver-10M (top)
L306	100uh
L401	100uh
L402	84uh
L403	Pi-Network
L404	30uh
L601	200uh
L602	Bifilar, Filter
L701	1st IF
L801	2nd IF
L1401	VFO Coil

L1402	200uh
L1403	200uh
L1404	200uh
L1501	200uh
L1601	200uh

TRANSFORMERS

Z401	Parasitic Suppressor
T1001	Audio Output
T1101	5500 kc BAL. MOD. Trans.
T1601	Feedback Trans.
T1602	Pwr Transformer

SWITCHES

S1A-E	Bandswitch
S2	Pwr On-Off (part of R1616)
S3	117VAC/12VDC Selector
S4	REC. TUNE-CW Switch

RELAY

K1	3PDT Relay-12VDC Coil
----	-----------------------

CRYSTALS

Y601	5502.4 kc-Crystal Filter
Y602	5502.4 kc-Crystal Filter
Y603	5500.4 kc-Crystal Filter
Y604	5500.4 kc-Crystal Filter
Y1501	5500 kc-Carrier Oscillator

TUBES

See Table II.

SEMI-CONDUCTOR

See Table II.

MISCELLANEOUS

J401	Antenna Coaxial Connector
J1601	Pwr Plug
J1603	Jet Plug
E1001	8 ohm Speaker
Mic.	SWAN Microphone

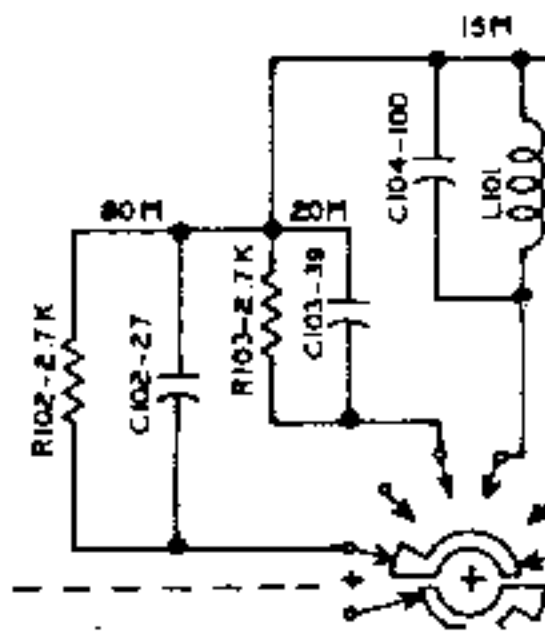
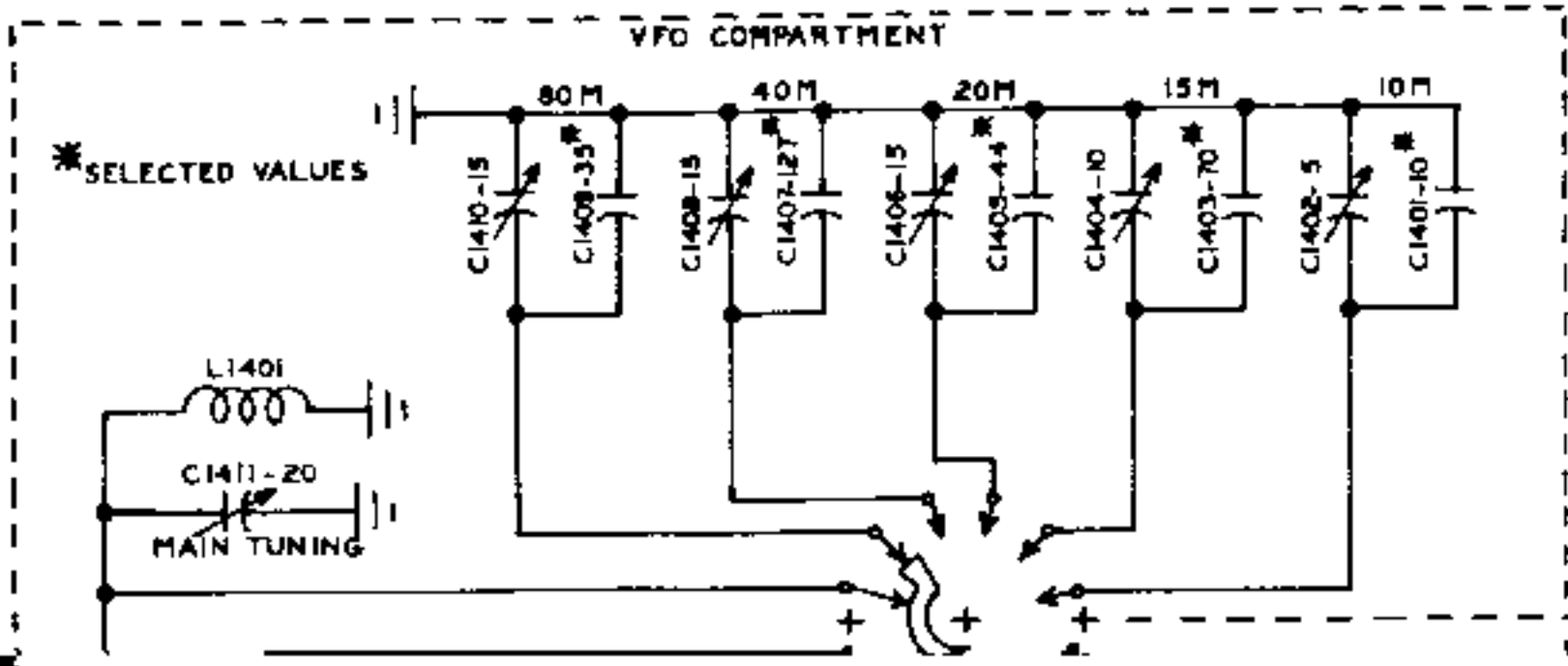
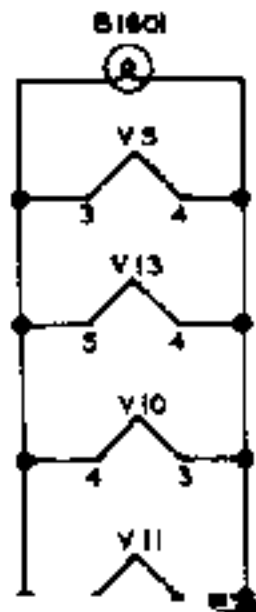

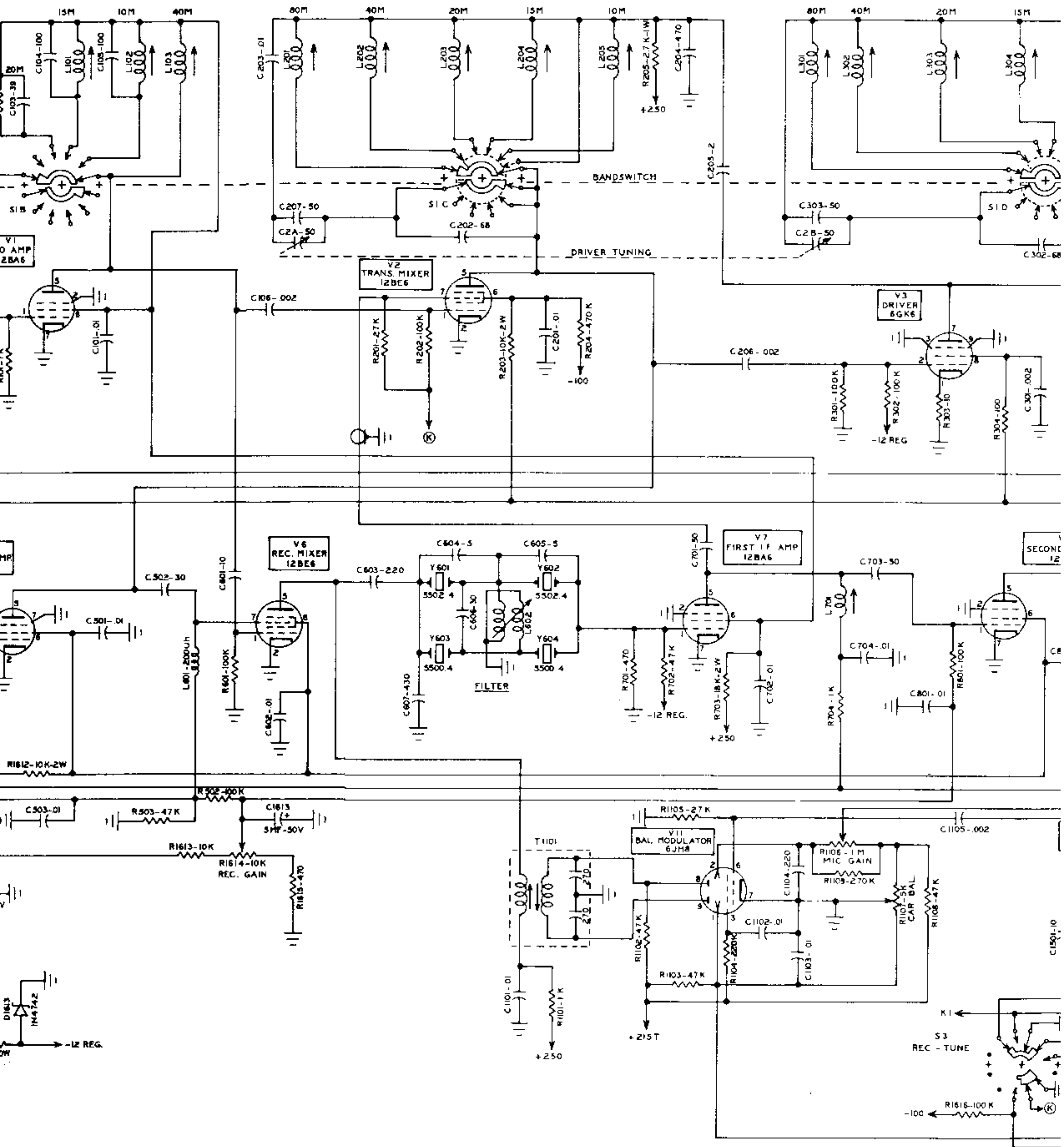

SCHMATIC DIAGRAM - 3
SWAN ELECTRONICS - Oc

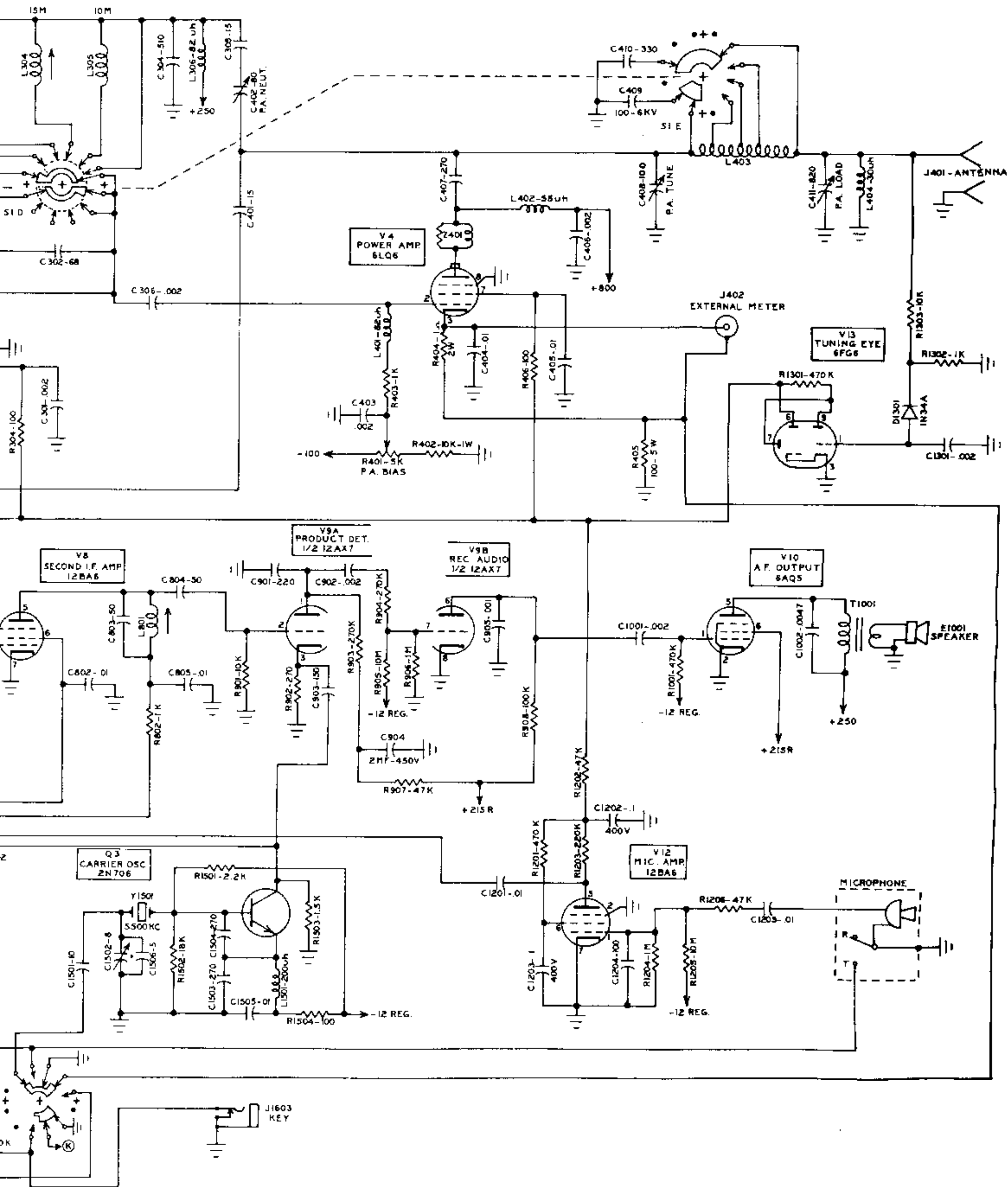

TABLE OF CONTENTS

INTRODUCTION	1
GENERAL	1
SPECIFICATIONS	2
CONTROLS AND VACUUM TUBES	3
INSTALLATION	4
GENERAL	4
FIXED LOCATION	4
P. A. BIAS ADJUSTMENT	4
MOBILE INSTALLATION	5
ANTENNAS	5
Mobile Antennas	7
Antenna Tuners	7
OPERATION OUTLINE	8
OPERATION	9
GENERAL	9
RECEIVER TUNING	9
TRANSMITTER TUNING	10
SSB VOICE OPERATION	12
CW OPERATION	13
CIRCUIT THEORY OF OPERATION	15
GENERAL	15
TRANSCEIVER SYSTEM	15
TRANSMIT MODE	15
RECEIVE MODE	19
T AND R SWITCHING	20
POWER SUPPLY SYSTEM	20
MAINTENANCE	21
GENERAL	21
TROUBLESHOOTING	21
TRANSCEIVER ALIGNMENT	27
Receiver Alignment	27
Transmitter P. A. Bias	4 - 27
Transmitter Alignment	28
Power Amplifier Neutralization	29
Carrier Balance Adjustment	30
VFO Calibration	30
PARTS LIST	
SCHEMATIC DIAGRAM	

ILLUSTRATIONS

FIGURE NUMBER	DESCRIPTION	PAGE
1	"The Cygnet"	1
2	Mobile Mounting	6
3	Mobile Mounting	6
4	External Meter Schematic	14
5	External Meter Conversion Chart	14
6	Cygnet Block Diagram	16
7	Crystal Filter Characteristics	18
8	Cygnet, Top View	24
9	Cygnet, Bottom View	25

TABLES

TABLE NUMBER	DESCRIPTION	PAGE
I	SPECIFICATIONS	2
II	CONTROLS AND VACUUM TUBES	3
III	OPERATION OUTLINE	8
IV	VFO AND CARRIER OSCILLATOR FREQUENCIES	22
V	VOLTAGE AND RESISTANCE CHART	23
VI	TROUBLESHOOTING CHART	26