

Dale
Price \$1.50

OPERATION AND MAINTENANCE

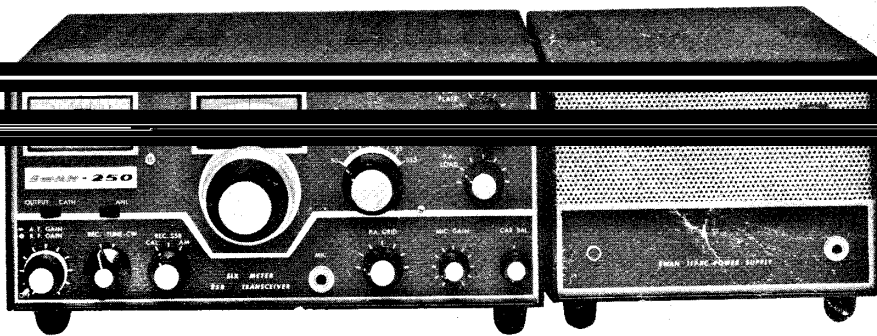

SWAN MODEL 250
SIX METER SSB TRANSCEIVER

 **SWAN**
ELECTRONICS
Oceanside, California

OPERATION and MAINTENANCE MODEL 250 SERIES Single Sideband Transceiver

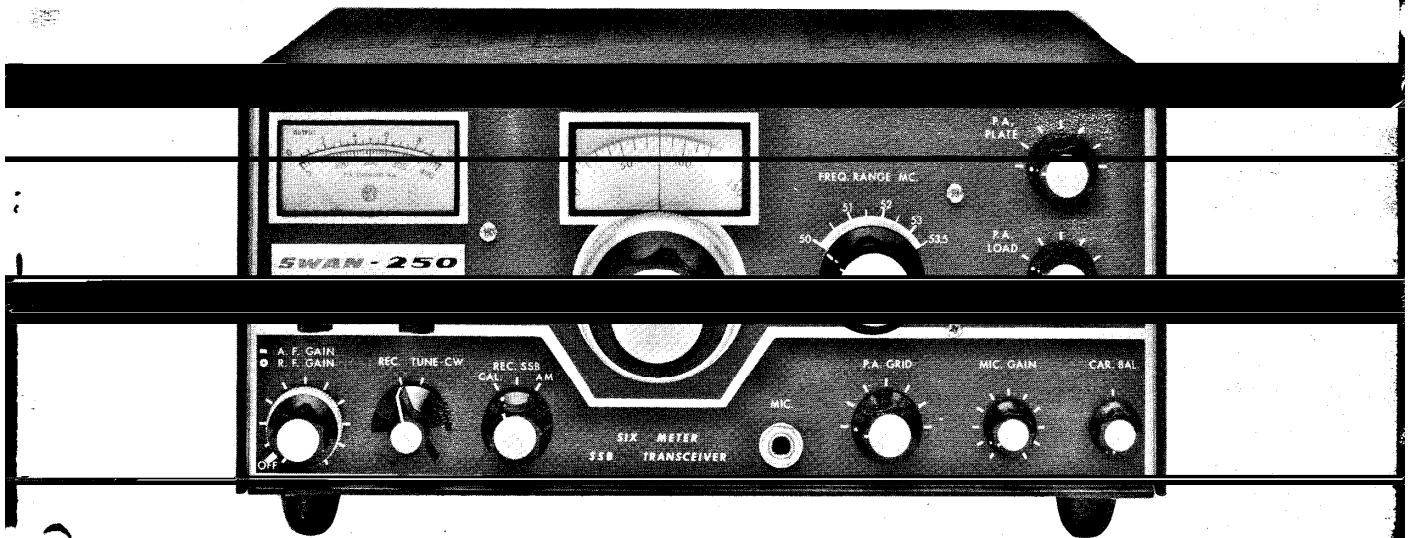

INTRODUCTION

The Swan Model 250 Single Sideband Transceiver is designed to be used for SSB, AM or CW communications in the 50-54 mc. amateur radio bands. MARS frequencies may also be covered by using the Model 405X oscillator accessory.

The Model 250 generates a single sideband signal by means of a crystal lattice filter, and the transceiver operation automatically tunes the transmitter to the received frequency. When operating in single sideband mode, the normally used upper sideband (USB) is employed.

Basic circuitry of the single conversion design has been proven in several thousand of the popular Swan transceivers. Mechanical, electrical, and

thermal stability is exceptionally high. All oscillators

push-to-talk operation is standard, with provision for plugging in the Model VX-1 accessory Vox unit for automatic voice control.

With a suitable power supply, operation may be fixed, portable, or mobile. Power input is rated at 240 watts, PEP, on single sideband, 180 watts on CW, and 75 watts on AM. The basic transceiver includes automatic gain control (AGC), and grid block CW keying.

Recommended power supplies are the model 117-XC for ac operation and model 14-117 for 12-volt dc operation.

 **SWAN**
ELECTRONICS
Oceanside, California

SPECIFICATIONS:

FREQUENCY RANGE

50-54 mc. (except for a narrow segment at 53.5 mc)

POWER INPUT

Single Sideband, Suppressed Carrier:
240 watts, PEP, minimum.

CW:

180 watts, dc input.

AM (Single Sideband with Carrier):

75 watts dc input.

DISTORTION

Distortion products down approx. 30 db.

UNWANTED SIDEBAND SUPPRESSION

Unwanted sideband down more than 40 db.

CARRIER SUPPRESSION

Carrier suppression greater than 50 db.

RECEIVER SENSITIVITY

Less than 0.5 microvolt at 50 ohms impedance for signal-plus-noise to noise ratio of 10 db. Noise figure better than 3 db.

AUDIO OUTPUT AND RESPONSE

Audio output, 4 watts to 3.2 ohm load. Response essentially flat from 300 to 3000 cps in both receive and transmit.

TRANSMITTER OUTPUT

Wide-range Pi-network output matches antennas essentially resistive from 15 to 500 ohms impedance.

METERING

Power amplifier cathode current 0-400 ma. and 0-10 relative output indicator.

FRONT PANEL CONTROLS

Rec-Tune-CW, AF Gain, R.F. Gain, Mic. Gain, Carrier Balance, PA Plate Tune, PA Grid Tune, PA Load, KC Tuning Dial, MC Tuning Dial, Meter Switch.

REAR PANEL CONTROLS AND CONNECTORS

Bias potentiometer, CW key jack, Jones plug power connector, Vox connector, Antenna jack, Auxiliary relay switching.

VACUUM TUBE COMPLEMENT

V1 · 6EW6 VFO Amplifier—
V2 · 12BE6 Transmitter Mixer —
V3 · 6GK6 Driver —
V4 · 6146B Power Amplifier
V5 · 6146B Power Amplifier
V6 · 6HA5 Receiver RF Amplifier
V7 · 6HA5 Receiver Mixer —
V8 · 6EW6 First IF Amplifier —
V9 · 12BA6 Second IF Amplifier —
V10 · 12AX7 Product Detector/Receive Audio —
V11 · 6BN8 AGC Amplifier/Rectifier —
V12 · 6GK6 Audio Amplifier —
V13 · 7360 Balanced Modulator —
V14 · 12BA6 Carrier Oscillator
V15 · 12AX7 Mic. Amplifier/Transmit Audio —
V16 · OA2 Voltage Regulator —

DIODE AND TRANSISTOR COMPLEMENT

Q1 · 2N706 Oscillator
Q2 · 2N706 Emitter Follower
Q3 · 2N706 Buffer Amp.
D1001 · Noise Limiter Diode
D1002 · Noise Limiter Diode
D1601 · 1N2974A Zener voltage regulator
D1602 · TS-2 Relay Silencing Diode

POWER REQUIREMENTS

Filaments · 12.6 volts, 4.5 amps, ac or dc
Relay · 12 volts dc, 250 ma.
Bias · -110 volts dc, 100 ma.
Medium voltage · 275 volts dc, 150 ma.
High voltage · 800 volts dc, 300 ma. Peak Trans.

DIMENSIONS AND WEIGHT

Height	5-1/2 in.	Depth	11 in.
Width	13 in.	Weight	17-1/4 lb.

A. CIRCUIT THEORY

GENERAL DISCUSSION

The Swan 250 transceiver provides single sideband, suppressed carrier transceiver operation, and generates the single sideband signal by means of a crystal lattice filter. To permit a logical discussion of this mode of operation, certain definitions are necessary. In a normal AM signal (double sideband with carrier), a radio frequency signal is modulated with an audio frequency signal. This is considered by many to be merely a case of varying the amplitude of the carrier at an audio rate. In fact, however, there are actually sideband frequencies generated, which are the results of mixing the RF and the AF signals. These sidebands are the sum of, and the difference between the two heterodyned signals. In the detection of this conventional AM signal, the two sidebands are mixed with the carrier to recover and reproduce the audio intelligence. This is an inefficient means of transmission, because only 25 percent of the transmitted power is used to transmit intelligence. There are other attendant drawbacks, also. The bandwidth of AM voice transmission is approximately 6 kc, while the actual demodulated audio is only approximately 3 kc. The result is inefficient use of the frequency band, and over half of the allotted band is unusable due to heterodynes, interference, and congestion.

In the single sideband, suppressed carrier mode of transmission, only one of the sideband signals is transmitted. The other sideband and the carrier are suppressed to negligible level. In addition to increasing the transmission efficiency by a factor of four, single sideband effectively doubles the number of stations or channels which can be used in a given band of frequencies.

It should be remembered that in the single sideband mode, the sideband and carrier are only suppressed, not entirely eliminated. Thus, with a transmitted signal from a transmitter with 40 db. sideband suppression, the other or unwanted sideband will be present, and will be transmitted, but its level will be 40 db below the wanted sideband. When this signal is received

will be present at a level of approximately S5. The same is true of carrier suppression. With carrier suppression of 50 db, and a signal level of 20 db over S9, carrier will be present at a level of approximately S3 to S4.

In the Model 250 transceiver, the single sideband suppressed carrier signal is generated by the crystal

lattice filter. See the block diagram and to Figures 1, 2, and 3.

SIGNAL GENERATION

When the push-to-talk switch on the microphone is pressed, the transmitter portion of the transceiver is activated, and it generates a single sideband, sup-

pressed carrier signal in the following manner. Carrier is generated by V14 Carrier Oscillator, which is a Pierce oscillator with the crystal operating in parallel resonance. This stage operates in both the transmit and receive modes. When transmitting, the RF output of the oscillator is injected into the control grid of the Balanced Modulator, V13. This balanced modulator is a beam deflection tube, and operates similar to a cathode ray tube in that the electron beam from the cathode is deflected to one output plate or the other by the charge appearing on the deflection plates. The carrier signal fed to the control grid of the balanced modulator appears on both plates of the output. The two plates are connected to Transformer Z1301 in push-pull, so the carrier signal cancels itself out in Z1301. The deflection plate DC voltages are adjusted by means of the carrier balance control so that the RF being fed to the output plates will cancel out, and the output from Z1301 will be zero. Audio signals from the Microphone Amplifier, V15, are applied as a modulating voltage to one deflection plate, and the two sidebands resulting from the sum and difference frequencies of the audio and carrier signals appear in the output of transformer Z1301. Carrier suppression is approximately 50 db.

The double sideband, suppressed carrier signal is then coupled from the secondary winding of Z1301 to the crystal filter, which suppresses the lower sideband, and permits only the upper sideband to be fed to the First IF Amplifier, V1. The carrier frequency is generated at approximately 10,698 kc.

The crystal filter is designed with a passband extending from 10,698.3 to 10,701.1 kc at the 6 db points. Thus, only audio modulation from 300 to 3100

Hz is transmitted. Q1, the VFO 2N706 Oscillator, operates in the common base configuration as a Colpitts oscillator. Q2, the Emitter Follower is used for isolation and impedance matching purposes. The extremely good regulation achieved through using the Zener diode regulator D1601 across the bias supply voltage, also

contributes to the stability. Q3 is a Driver Amplifier stage which provides further isolation. The VFO in the Model 250 transceiver provides good stability over the initial warm-up period. Drift from a cold start will be approximately 2 kc for the first hour. After the initial warm-up period, drift will be negligible.

The single sideband, suppressed carrier signal from the First IF Amplifier is fed to the Transmitter Mixer,

V2, where it is heterodyned with the VFO signal. The resultant signal at the desired transmit frequency is amplified by the Driver, V3, and the Power Amplifiers, V4 and V5. The signal from the VFO Amplifier is initiated in the transistorized VFO-Emitter Follower circuit Q1, Q2, and Q3. The signal from the VFO is routed to the VFO Amplifier.

1 MODEL 250 TRANSCEIVER

A. Circuit Theory (Cont)

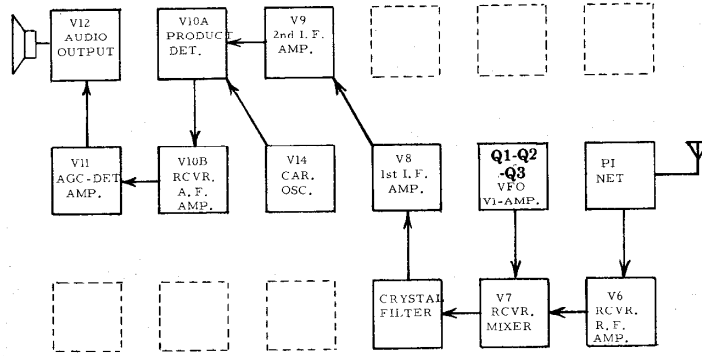

FIGURE 1 BLOCK DIAGRAM, RECEIVE MODE

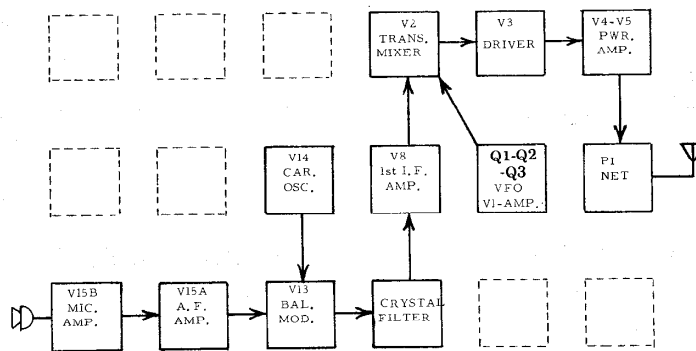

FIGURE 2 BLOCK DIAGRAM, TRANSMIT MODE

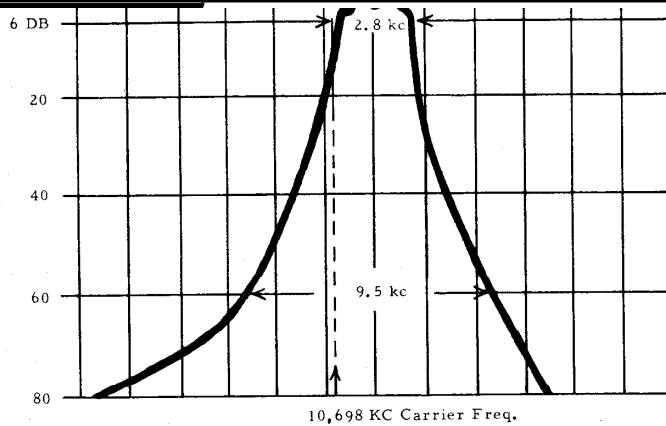

FIGURE 3 CRYSTAL FILTER, TYPICAL CHARACTERISTIC

1 MODEL 250 TRANSCEIVER

A. Circuit Theory (cont.)

TUNE AND CW OPERATION

Normally, the frequency of the carrier oscillator is approximately 300 cps outside the 6 db passband of the crystal lattice filter. In TUNE position, to enable the transmitter to be tuned to the maximum power output condition, the frequency of the carrier oscillator is moved approximately 500 cps to place it well within the passband of the crystal lattice filter. At the same time, one deflection plate of the balanced modulator is grounded, unbalancing the modulator and allowing full carrier input for tuning purposes. A similar procedure is followed for CW to allow full carrier output during CW operation. During CW operation, the cathode of V15A is disconnected from ground. This allows CW operation with no accidental audio modulation from the microphone.

RECEIVE

In RECEIVE position, or at any time when the transmitter is not in TRANSMIT, all circuits used in transmitting are disabled through the relay controlled circuits, K1, K2. The relays are energized for transmitting and de-energized for receiving. Relay K2, when de-energized, connects the antenna to the receiver input coils, L 601-602, and to the Receiver RF Amplifier, V6. The interstage coils, L603-604 couple V6 to the control grid of the Receiver Mixer, V7. The local oscillator signal from the VFO Amplifier is now used to heterodyne the received signal to the IF frequency. All IF amplification is accomplished at this frequency, nominally 10.7 mc, through V8 and V9 IF amplifiers. In the Product Detector V10A, the IF signal is heterodyned with the carrier frequency generated by Carrier Oscillator, V14. The resultant audio signal is then amplified by V10B, which then couples to V11, the AGC amplifier, and V12, the output audio stage.

FREQUENCY CALIBRATION

Frequency calibration of the Model 250 is in 5 kc increments on the 0-500 kc vernier tuning dial. Accuracy of this dial reading depends directly on the setting of the Megacycle Dial. When it is set to minimum frequency, (maximum tuning capacity), it will be at the 50 mc mark, and zero on the vernier dial will be 50 mc. Tuning the vernier dial will then change the frequency from 50 to 50.5 mc. Other .5

Megacycle Dial up in frequency in .5 mc steps.

Dial accuracy and tracking are quite good on the 250, but caution must always be observed when

using frequency is recommended. The optional calibrator kit will serve this purpose, and installs quite easily inside the transceiver.

TRANSMIT AND RECEIVE SWITCHING

Transmit and receive switching is performed by relays K1 and K2. In TRANSMIT position, only

those tubes that operate in the transmit mode are operative, all others being biased to cutoff through the relay contacts. In the RECEIVE position, with the relays de-energized, the tubes that are used only in transmit are cut off in the same manner. Relay K2 when de-energized, feeds signals from the antenna to the receiver, and is used also to control external switching circuits.

POWER RATING

The Swan 250 is capable of 240 watts, PEP input under steady state two-tone test conditions, when operated with any of the recommended power supplies. The peak envelope power, when voice modulated, is somewhat greater, typically 280 watts, or more.

Recommended power supplies produce a no-load plate voltage of approximately 925 volts. Under TUNE conditions, or CW operation, this voltage will drop to approximately 740 volts. Under steady state two-tone modulation, the voltage will drop to approximately 770 volts. If the power amplifier idling current is 50 ma, and the two-tone current, just before flat-topping, is 220 ma., the peak two-tone current will be 320 ma. Under these conditions the PEP input will be 770 volts time 320 ma, = 240 watts. Under voice modulation, because average power is considerably less, the power amplifier plate and screen voltages will be maintained higher, even during voice peaks, by the power supply filter capacitors. Peak plate current will therefore also be higher than with two-tone test conditions. Readings of cathode current will not reflect this power input, however, because of the damping in the cathode current meter. Cathode current readings under normal voice input should not exceed approximately 125 ma.

B. INSTALLATION

GENERAL

The Swan 250 transceiver has been designed to provide the utmost in ease of operation, stability, versatility, and enjoyment. Maximum enjoyment from your Swan will depend to a great extent on the installation. For fixed station or portable use, operation with the Model 117-XC power supply provides a compact arrangement with maximum ease of operation. All switching is performed in the transceiver. For mobile installations, the Model 14-117 supply provides similar switching arrangements,

of broadcast receiver speaker.

POWER SUPPLY

The Swan Models 117-XC or 230-XC Power Supplies provide the necessary voltage required by the transceiver for AC operation. The supplies come equipped with a pre-wired plug and cable, all ready for plugging into the transceiver. (The Model 14-117

connector plug, fuses, and installation hardware. The Jones plug for connection to the transceiver is furnished with the unit.

1 MODEL 250 TRANSCEIVER

B. Installation (cont.)

Power requirements for the Swan 250 are listed in the following table. Pin connections to the Jones type power connector are listed as an aid in connecting other brands or home-brew supplies.

EXTERNAL CONNECTIONS

Audio output from the transceiver is provided at pin 12 of the Jones plug. The other speaker lead goes to the common chassis ground at pin 6. Output impedance is between 3 and 4 ohms. For mobile installations, the car broadcast speaker may be used, in which case a DPDT selector switch should be installed to select the broadcast receiver or transceiver output. (See Figure 9.)

JONES PLUG CONNECTIONS

	Pin	Nominal	Minimum	Maximum
High Voltage	8	800 VDC 300 MA	600 VDC Low Pwr.	900 VDC Hi. Power
Medium Voltage	10	275 VDC 150 MA	225 VDC	325 VDC
Bias Voltage	3	-110 VDC 100 MA	-100 VDC	-130 VDC
Filament Voltage	4	12.6V* 4.5 amp	11.5 V	14.5 V
Relay Voltage	5	12 VDC 250 MA	10 VDC	14.5 VDC

*AC or DC

MICROPHONE

The microphone input is designed for high impedance

serious consideration. The crystal lattice filter in the transceiver provides all the restriction necessary on audio response, and further restriction in the microphone is not required. It is more important to have a microphone with a smooth, flat response throughout the speech range. The microphone plug must be a standard 1/4 in. diameter three-contact type. The tip connection is for push-to-talk relay control, the ring connector is the microphone terminal, and the sleeve is the common chassis ground. The microphone manufacturer's instructions should be followed in connecting the microphone cable to the plug. With many microphones, the push-to-talk button must be pressed to make the microphone operative. For VOX operation, this feature may be disabled, if desired, by opening the microphone case and permanently connecting the contacts which control the microphone.

ANTENNA

Any of the common antenna systems designed for use in the 6 meter amateur band may be used with the Swan transceiver, provided the input impedance of the transmission line is not outside the capability of the pi-output matching network. The transmission line should be of the coaxial cable type. An antenna system should show a standing wave ratio of less than 2:1 when using 50 or 75 ohm coaxial transmission line. If open-wire or balanced type transmission line is used with the antenna, a suitable antenna tuner is recommended between the transceiver and the feedline. Various types of antennas are available from your dealer, and for the antenna builder, many are described in the amateur handbooks, also available from your dealer. Remember that even the most powerful transmitter is useless without a proper and efficient antenna system.

C. OPERATION

Before connecting any cables to the Swan 250 perform the following steps:

1. Rotate the PA BIAS control on the rear chassis apron, fully counter clockwise.
2. Rotate the REC-TUNE-CW located on the lower left of the front panel counter clockwise to REC.
3. Rotate the RF GAIN Control counter clockwise to operate the power switch to OFF.

POWER SUPPLY AND ANTENNA CONNECTIONS

1. Connect the 50 to 75 ohm antenna feedline to the coaxial connector on the rear chassis panel.
2. Connect the power supply cable to the Jones connector on the rear chassis apron.
3. Connect the power supply to the proper voltage source.

The Swan Model 250 may be operated from 117 volts, ac, 50-60 cycle power with the Model 14-117

The Model 250 may be operated from a 12 volt dc source with the Swan Model 14-117 power supply.

WARNING

DANGEROUS HIGH VOLTAGE IS PRESENT ON THE PLATE OF THE POWER AMPLIFIER WHENEVER THE POWER SUPPLY IS ENERGIZED. NEVER TURN POWER ON WHEN THE POWER AMPLIFIER COVER IS REMOVED. HIGH VOLTAGE IS ALSO PRESENT AT PIN EIGHT OF THE POWER PLUG.

RECEIVE OPERATION

1. Rotate the RF GAIN Control clockwise to full clockwise position. The power switch will operate applying filament, relay, bias, medium, and 800 volt high voltage to the transceiver.

CONTROL FUNCTIONS

<p>ON-OFF SWITCH (On RF Gain Knob) Turns power supply on and off.</p> <p>REC-TUNE-CW Receive All voltages are applied to transceiver.</p> <p>Transmit 12 volt dc circuit through relay K1 and K2 is completed, and tubes used only in receive are biased to cutoff.</p> <p>Tune-CW All circuits for transmit are energized, as above, but one deflection plate of the balanced modulator is grounded, capacitor C1401 in the carrier oscillator is removed from ground.</p> <p>MIC. GAIN Controls potentiometer R1503 in the grid of V15A and controls amount of audio to the unbalanced modulator.</p> <p>CAR. BALANCE Controls potentiometer R1308 in the balanced modulator deflection plate circuit, and permits nulling out the carrier.</p> <p>RF GAIN Controls variable resistor R801, common in the cathodes</p>	<p>of RF Amplifier, V8 and V9 IF Amplifiers.</p> <p>RECEIVER FUNCTION SWITCH Changes receiver from SSB to AM mode and turns crystal calibrator on and off, if the calibrator kit is installed.</p> <p>AF GAIN Controls potentiometer R1201 in grid circuit of V12 AF Output, and controls audio volume.</p> <p>VERNIER KC TUNING Controls C1816 in frequency determining tank circuit of VFO.</p> <p>MEGACYCLE TUNING Controls C1811 in VFO.</p> <p>PA GRID Controls C105 in plate tanks of transmitter mixer and driver.</p> <p>PA TUNE Controls C415 on pi-network to tune final power amplifier plate to resonance.</p> <p>PA LOAD Controls C416 in pi-network to match impedance of output load. Tunes input to Receiver RF Amplifier.</p>
--	---

2. Wait approximately one minute to allow the tube filaments to reach operating temperature. During this period, perform the following steps:
 - (a) Rotate MIC. GAIN fully counter-clockwise.
 - (b) Rotate CAR. BAL. control to the mid-scale position, with white dot on knob aligned with the long index mark on the panel.
 - (c) Preset PA PLATE control to mid-position.
 - (d) Preset PA GRID control to mid-position.
 - (e) Preset PA LOAD to mid-position.
 - (f) Set tuning dial to desired operating frequency.
 - (g) Set AF GAIN control to approximately 3 o'clock position.
 - (h) Set receiver function switch to SSB or AM, whichever mode is desired.
3. Adjust the PA GRID control for maximum receiver noise. Then tune across the band for signals.
4. The main tuning knob is labeled FREQ

dex mark. The vernier tuning dial, viewed through the window, will then read the low end of the band directly in kilocycles. To tune higher in the band, the main tuning control must be advanced .5 mc (500 KC) at a time.

A 500 KC calibrator kit is available from your dealer. When this is installed, it will prove useful in setting the main tuning dial to an exact 500 KC multiple. This calibrator is turned on by switching the receiver function control to the CAL. position.

NOTE: The vernier dial scale is adjusted to read correctly, plus or minus 10KC when tuning from 50 to 50.5 mc. Accuracy will be slightly less in the 50.5 to 51 mc range, and will gradually deviate, until at the high end of the band the vernier dial scale will not be accurate. With a 500 KC calibrator, any 500 KC multiple may be accurately determined.

CAUTION: If a calibrator, either internal or external of some type is not used, care must be exercised to stay within band limits. If you don't know exactly where the edge of the band is

6 meter band, set this control to the 50 mc in-

50 to 50.1 mc is for CW only.

5. The 5th harmonic of the carrier oscillator will be heard at 53.49 mc and will make operation at this exact frequency difficult. Except for this one spot, the model 250 will provide complete band coverage.
6. A panel controlled noise limiter will reduce sharp impulse noise on both sideband and AM signals. Its effectiveness will vary somewhat, depending on the type of noise interference. It will not eliminate ignition noise, but ~~it will reduce it~~. In mobile installations, it will still be necessary to install ignition suppression and by-passing in the automobile engine.

RECEIVER TUNING — IMPORTANT, READ CAREFULLY.

Precise tuning of a single sideband signal is very important. Do not be satisfied to merely tune until the voice can be understood, but take the extra care of setting the dial to the exact spot where the voice sounds natural. Above all, avoid the habit of tuning so that the voice is pitched higher than normal. This is an unfortunate habit practiced by quite a number of operators. The following points help to explain the effects of mistuning:

1. If you tune so the received voice is higher than normal pitch, you will then transmit off frequency, and your voice will sound lower than

probably retune his dial to make you sound right. If you keep this up, you'll gradually waltz one another across the band. If both of you are mistuning to an unnatural higher pitch, you'll waltz across the band twice as fast. (And someone will no doubt be accused of frequency drift.)

2. Mistuning results in serious harmonic distortion. ~~the voice should be quite notice~~

if they don't know how the other person's voice actually sounds, they can't tune him in properly, but this is not true. With a little practice, it will be fairly easy to tell. Some voices are relatively rich in harmonics, and are easier to tune in than a person with a "flat" voice. Also, a transmitter which is being operated properly with low distortion will be easier to tune in than one which is being overdriven and is generating excessive distortion. There is no mistaking when you have a station tuned right on the nose.

3. A vernier control for receive frequency, sometimes referred to as "incremental tuning," is not available on the Swan 250. Such a device is not necessary if proper tuning habits are exercised.
4. Your Swan 250 will automatically transmit on exactly the same frequency as the one to

which you are listening. There is no adjustment for making them the same, since by using the same oscillator for both send and receive, it happens automatically. If separation of receive and transmit frequency control is desired, the model 210 VFO unit may be used. The model 22 dual VFO adaptor must be installed in the 250 in order to accommodate the 210.

TRANSMITTER TUNING

The Model 250 covers frequency ranges outside the amateur bands. Care must be exercised not to transmit on these frequencies.

Tuning of the transmitter is not complicated, provided the few simple steps are followed in the correct order. Do not attempt initial tuneup without first performing the procedures for Receive operation described above. The following procedures assume that the unit has been checked out in Receive position, and a high impedance push-to-talk microphone is inserted in the MIC. JACK.

1. Set the meter switch to CATH. position.
2. Press Push-to-Talk to place unit in TRANSMIT, read the cathode current on the meter.
3. Quickly rotate the CAR. BAL. control on the front panel until the meter reads minimum
4. Next, adjust the PA BIAS control on the rear of the chassis until the meter reads 40 ma.
5. Next, move the meter switch to OUTPUT position and set PA LOAD to 12 o'clock.
6. Set the CAR. BAL. to about 10 o'clock. Then, press the Mic. button and quickly adjust PA PLATE and PA GRID for maximum OUTPUT ~~reading. Hold the Mic. button pressed just~~
7. Switch to TUNE-CW position, and quickly adjust PA PLATE and PA LOAD for maximum OUTPUT reading. Tuning one of these controls will require re-tuning the other, so it will be necessary to adjust back and forth a few times in order to reach the maximum reading. This tuning step should be done quickly in order to avoid overheating the PA tubes. Generally, a limit of 20 seconds tuning time should be observed. If more time is required, switch back to REC. for a minute of cooling.

NOTE: We cannot overemphasize the importance of avoiding lengthy tune periods! 6146B tubes are quite expensive and can be damaged seriously in a short time if abused. Although the factory will honor all reasonable warranty claims, we cannot replace tubes which have been damaged due to excessive plate or screen grid dissipation. Examination of defective

tubes will be necessary before factory replacement can be authorized.

8. After tuning for maximum output, move the meter switch to CATH. position in order to observe PA cathode current. Switch to TUNE-CW position briefly to make this reading. When properly tuned, the PA cathode current will read between 200 and 250 ma. This will vary somewhat between sets and tubes, and will serve chiefly as an indication of a change in tube condition. If the reading drops off substantially, the 6146B tubes, as well as other tubes in the transmitter chain, should be checked.

NOTE: The OUTPUT meter reading is a relative measurement, and does not directly indicate output power. Feedline impedance and reactance will affect the reading substantially. Primarily, the OUTPUT meter position is intended as a means for tuning to maximum output.

9. For SINGLE SIDEBAND transmission: Leave the function switch in REC. position. Press the Mic. button and adjust CAR. BAL. for minimum output. Then advance the MIC. GAIN control and speak into the Mic. Set the control to the position where the average meter reading with voice modulation is about 125 ma. (Meter switch in CATH. position.) With the average microphone, the MIC. GAIN control will be set to 9 or 10 o'clock for close speaking. Avoid excessive MIC. GAIN setting, as this causes adjacent channel splattering and distortion.

10. For AM transmission: Tune the transmitter for maximum output, as described through step 8. Then, leaving the function switch in REC. position, press the Mic. button and adjust CAR. BAL. for 80 to 90 ma. PA cathode current. Advance the MIC. GAIN control to the position where average voice modulation produces a slight upward flicker of the meter reading. Avoid excessive MIC. GAIN setting, as this causes adjacent channel splattering and distortion on the transmitted signal.

11. For CW transmission: Tune the transmitter through step 8. Insert a key in the jack provided on the back of the set. Switch to TUNE-CW to transmit, and back to REC. for receiving. The transmitting frequency will be approximately 800 cycles higher than the receiving frequency. Thus, when two transceivers are tuned to the same frequency, they will hear one another on CW with an 800 cycle tone.

NOTE: The key jack requires a standard 1/4 in. diam., 2 circuit plug. If key clicks are noticeable on transmissions, a .47 or .5 mf capacitor of 200 volt rating may be connected across the key terminals for additional key click suppression.

D. ALIGNMENT AND TROUBLESHOOTING

RECEIVER SECTION:

1. Adjustment of double tuned RF and Mixer Coils, L601, L602, L603, L604. Feed 2 microvolts from a 50 mc signal generator into the antenna jack, and connect an AC Output Meter to pin 3 of the octal VOX socket. This is the high voltage plate terminal of the AF output stage. Adjust the 4 input coils for maximum output. Then, connect the antenna to the set, and adjust the antenna coil, L601, for maximum AF output, either on a signal or on antenna noise.
2. Receiver RF Amplifier Neutralization. Improper neutralization of V6 will be apparent when adjusting L602, L603, and L604. These coils will normally tune quite broadly, unless neutralization is not correct, in which case, the coil adjustments will become rather sharp and critical, due to regeneration. If neutralization is far enough out of adjustment, there will be sudden changes in noise level when adjusting the coils, accompanied by birdie-like signals. The neutralizing capacitor is a mica trimmer, C604, located under the chassis next to L603. Adjust it carefully in the direction which reduces noise level and broadens coil tuning.

NOTE: With some antenna loads having reactive components or high SWR, it may be necessary to adjust neutralization slightly to reduce regeneration.

3. Adjustment of output IF coil, Z901 (located in front of V9). To peak this circuit, switch the receiver to AM mode, and adjust for maximum AF noise output.
4. Receiver injection from the VFO amplifier

L101, C104, and C105A. However, these are also transmitter adjustments, so normally they are not adjusted in receive mode, except to peak C105, the front panel control (PA GRID) for maximum noise level.

5. Loss of receiver volume or sensitivity will normally require tube testing. Voltages may be measured and referred to the voltage chart to trace possible failure of a resistor or capacitor. However, a high percentage of problems will involve one or more of the tubes. In the received circuitry, these will be: V1, V6, V7, V8, V9, V10, V11, V12, and V14.

FREQUENCY CALIBRATION, APPLIES TO BOTH RECEIVE AND TRANSMIT MODES:

The Megacycle Dial is C1811, and is set to exactly maximum capacity when tuning the lower 500 KC of the 50 mc amateur band.

The Vernier Tuning Dial is C1816, and it is calibrated in kilocycles from zero to 500. On the right side of the VFO compartment are

I MODEL 250 TRANSCEIVER

C. Operation (Cont.)

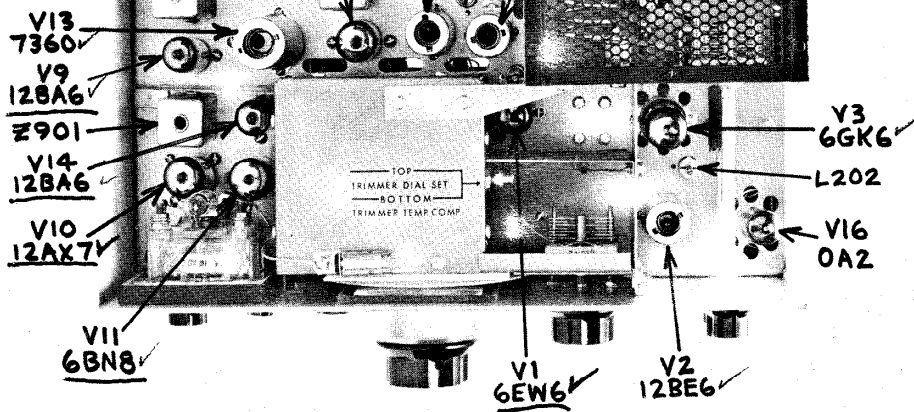
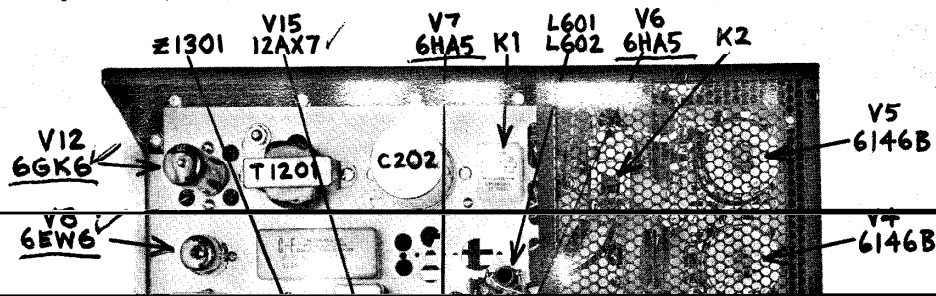

FIGURE 4
TOP VIEW
MODEL 250
TRANSCEIVER

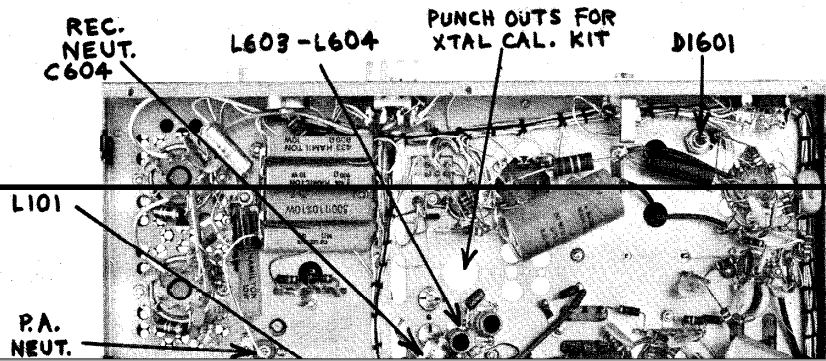
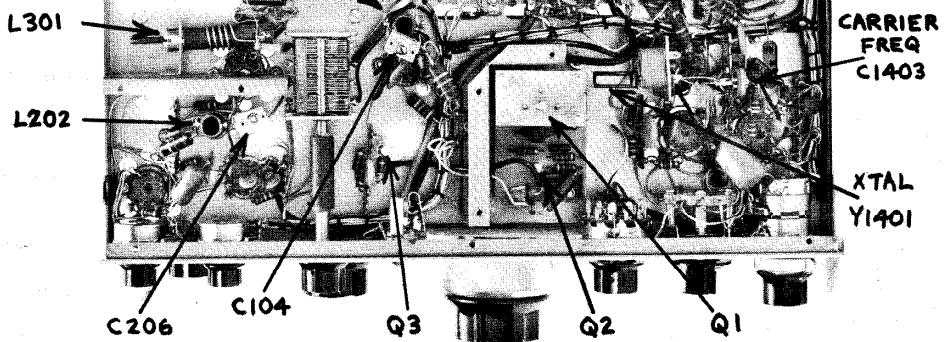

FIGURE 5
BOTTOM VIEW
MODEL 250



two locking type trimmers. The top one is C1812, and is used for setting dial calibration. The lower one is C1814, and it is adjusted only when temperature compensation needs to be changed. A frequency calibrator is required before adjusting C1812. The 500 kc crystal calibrator kit which is available for installation in the 250 may be used for this purpose.

CALIBRATION PROCEDURE:

1. Set C1811, the megacycle dial, to maximum capacity. Determine this by moving a signal on the kilocycle dial as far up the 0-500 dial scale as possible. In other words, as the MC dial is turned toward greater capacity, it will cause a given signal to move upward on the 0-500 kc scale. Rock the MC dial back and forth, until it is determined that maximum capacity has been reached. The index line on the MC dial will be quite close to the 50 MC panel index at this time.

NOTE: The MC dial is purposely made to turn quite hard, since it will not be moved very often and will not want to be bumped out of adjustment. Tension may be relieved, or tightened further, by means of the No. 6 Allen screw set in the aluminum bearing block located between the panel and the MC knob.

brator signal on the 0-500 kc dial. It should come in at zero on this dial. Adjust the VFO trimmer, C1812, so it does.

Note that with this calibration system, the frequency cannot be tuned below 50 mc as long as the KC dial is not tuned below the zero index. Adjustment of the mc dial can only move the frequency up higher in the band. This is the reason for wanting to make sure the MC dial is set exactly at maximum capacity before setting C1812.

After the above calibration adjustment has been made, the MC dial will read approximately correct. As it is moved up in .5 mc steps (500 kc steps), the KC dial will tune 50.5 to 51 mc, 51.51.5 mc, etc. Accuracy of the KC dial, however, will be most nearly correct in the 50-50.5 mc range. It will be quite close in the 50.5-51 mc range, and then will begin deviating to where in the 53.5-54 mc range it will be useful primarily as a logging scale. With the 500 kc calibrator, any 500 kc point can be accurately determined, and other frequencies can be closely interpolated.

the 50 mc index mark on the MC dial is actually 49.5 mc. After the mc dial has been set to exactly maximum capacity, locate the 50 mc calibration signal on the KC dial, as previously described. But, instead of adjusting C1812 so that 50 mc comes in at "zero" on the KC dial, gradually "walk" the 50 mc signal up to the 500 index mark on the KC dial by carefully moving C1812. The 49.5 mc harmonic from the 500 kc calibrator will now be found by tuning the KC dial down to "zero." The MC dial will now be offset by .5 mc, and 50 mc will actually be at the 50.5 index, etc.

TRANSMITTER ADJUSTMENTS

ADJUSTMENT OF CARRIER FREQUENCY

- A. With dummy load and output meter attached, tune transceiver for maximum output.
- B. Null out carrier with PTT pressed and set resting plate current to 40 ma with bias pot.
- C. Connect AF generator to MIC JACK, adjust MIC. GAIN full CCW.

Procedure:

1. With AF generator at 1500 cps, increase MIC. GAIN to produce a 75 ma reading on the meter.
2. Adjust 3001 for maximum meter reading for maximum meter reading.
4. Adjust MIC. GAIN for meter reading of 200 ma.
5. Set AF generator to 300 cps. Adjust C1402 for meter reading of 75 ma.

PA NEUTRALIZATION

1. Connect a dummy load to the antenna jack.
2. Set PA tune and PA load controls to 9 o'clock, and frequency to approximately 50.2 mc.
3. Press Mic. button, insert a small amount of carrier with the Car. Bal. control, and adjust PA grid for maximum PA cathode current. Then adjust Car. Bal. control for 100 ma meter reading. Do not hold Mic. button pressed for more than a few seconds during this adjustment.
4. With the Mic. button pressed, and the PA cathode reading 100 ma, slowly turn the PA tune control from 9 o'clock to 3 o'clock. A

done by adjusting the VFO trimmer, C1812, so that

which eliminates the peak.

DRIVER STAGE ADJUSTMENTS

1. Driver coils, L101, L201, L301. Set frequency to 50.2 mc, and PA grid control to 10 o'clock. Press the Mic. button, and insert carrier for about 100 ma PA cathode reading. Tune PA plate for resonance dip.
2. Adjust L101, L201, L301 for maximum meter reading.
3. Driver coil tracking has been factory adjusted and will not normally require further adjustment. If operation at the high end of the 6 meter band is required, and output power drops excessively, tracking can be adjusted by turning mica trimmers C104 on the VFO amp., and C206 on the transmit mixer stage. The trimmers should be peaked at the high frequency end, and the coil cores at the low end, with these adjustments repeated back and forth in the usual manner until proper tracking is achieved.

TROUBLESHOOTING GUIDE											
EFFECT	POSSIBLE CAUSE	VOLTAGE CHART									
		PIN NUMBER									
		1	2	3	4	5	6	7	8	9	
IDLING CURRENT UNSTABLE	1. Defective 6146B 2. Defective Bias Potentiometer 3. Defective Bias Supply	V1	R	0	.75	6.3	0	140	140	0	
		6EW6	T	0	.75	6.3	0	135	135	0	
		V2	R	-115	0	12.6	0	280	235	-115	
		12BE6	T	-5	0	12.6	0	260	85	-25	
		V3	R	0	-33	0	6.3	0	0	280	280
		6GK6	T	0	-5	0	6.3	0	0	275	275
		V4	R	0	6.3	0	0	-70	0	0	0
		6146B	T	0	6.3	260	0	-70	0	0	0
		V5	R	0	12.6	0	0	-70	0	0	0
		6146B	T	0	12.6	260	0	-70	0	6.3	0
ABILITY TO TUNED TO 200-300 MA	1. V2, V3, V4, V5 Defective 2. Driver Stage Improperly Tuned 3. Trans. Mixer Improperly Tuned 4. VFO Amplifier Improperly Tuned 5. Antenna Not Resonant at Frequency 6. Defective Transmission Line	V6	R	0	0	6.3	12.6	280	0	28	
		6HA5	T	0	0	6.3	12.6	-4	0	0	
		V7	R	0	0	0	6.3	280	0	4	
		6HA5	T	.75	0	0	6.3	1.1	0	0	
		V8	R	-6	.4	12.6	6.3	280	200	0	
		6EW6	T	0	.75	12.6	6.3	250	125	0	
		V9	R	-6	0	12.6	0	260	125	1.75	
		12BA6	T	-75	0	12.6	0	260	-75	0	
		V10	R	125	0	1.25	12.6	0	200	0	1.8
		12AX7	T	40	-25	.4	12.6	0	260	-100	0
SUFFICIENT BAND SUPPRESSION	1. Excessive MIC Gain 2. Incorrect PA Load Adjustment. 3. Carrier Oscillator Frequency Incorrect	V11	R	-75	0	-75	6.3	12.6	-1.5	230	25
		6BN8	T	0	0	0	6.3	12.6	0	85	10
		V12	R	0	-1.5	0	12.6	6.3	0	260	260
		6GK6	T	0	-26	0	12.6	6.3	0	280	260
		V13	R	0	0	-115	6.3	0	0	0	28
		7360	T	0	90	-1	6.3	0	150	150	25
		V14	R	-4	0	0	12.6	50	85	1.25	
		12BA6	T	-25	0	0	12.6	50	85	1.25	
		V15	R	75	-25	0	6.3	6.3	120	0	.75
		12AX7	T	40	-30	0	6.3	6.3	38	0	.25
CROPHONICS RECEIVER	1. Z901 Improperly Tuned 2. V14, V10, V8, V7, or V6 Defective	V16	R	150	0	0	0	150	0	0	
		OA2	T	150	0	0	0	150	0	0	
W RECEIVER SENSITIVITY	1. Pa Grid, Plate, or Load Improperly Set 2. Bandswitch Improperly Set 3. K2 Back Contacts Defective 4. V6, V7, V8, V9, V10, V11, V12 Defective										

VOLTAGE CHART MOD 250

All voltage measurements made with Simpson Model 260, 20K Ohms per volt, or equivalent.

NEW PARTS LIST

CAPACITORS

All capacity values listed in pico farads, unless otherwise specified.

C101	.002, 20% Z5U	C804	.01, +80-20 Z5U
C102	.01, +80-20 Z5U	C805	.01, +80-20 Z5U
C103	.002, 20% Z5U	C806	10 pf, 10% N1500
C104	20 pf Mica Trimmer (089-003)	C807	.001, 20% Z5F
C105 A-B-C-D	4 Section variable, 5 pf per section	C901	.47 mf, 100 v
C106	.002, 20% Z5U	C902	.01, +80-20 Z5U
C107	1 pf, 10% QC	C903	.01, +80-20 Z5U
C201	.1 mf 200 volt	C904	.01, +80-20 Z5U
C202 A-B-C	40-30-10 mf, 450 wv <u>electrolytic</u>	C1001	50 pf, 5% DM-15
C203	.002, 20% Z5U	C1002	220 pf, Z5U
C204	.002, 20% Z5U	C1003	.002, 20% Z5U
C205	.002, 20% Z5U	C1004	500 pf, Z5U
C206	20 pf Mica Trimmer (089-003)	C1005	.001, 20% Z5U
C301	.002, 20% Z5U	C1006	.001, 20% Z5U
C302	.002, 20% Z5U	C1007	.22, 200 v
C303	470 pf, 5% DM-19	C1101	.001, 20% Z5U
C304	.002, 20% Z5U	C1102	.01, +80-20 Z5U
C401	.002, 20% Z5U	C1103	.002, 20% Z5U
C402	.002, 20% Z5U	C1104	.001, 20% Z5U
C403	.002, 20% Z5U	C1201	.01, +80-20 Z5U
C404	.002, 20% Z5U	C1202	220 pf, Z5U
C405	.002, 20% Z5U	C1203	.1 mf, 200 v
C406	.002, 20% Z5U	C1204	.0047, 1000 v
C407	.002, 20% Z5U	C1205	.01, +80-20 Z5U
C408	.002, 20% Z5U	C1301	.01, +80-20 Z5U
C409	10 mf, 150 wv <u>electrolytic</u>	C1302	.01, +80-20 Z5U
C410	.002, 2 kv Z5U	C1303	.01, +80-20 Z5U
C411	.002, 2 kv Z5U	C1304	220 pf, Z5U
C412	270 pf, 2.5 kv Mica	C1305	.01, +80-20 Z5U
C413	270 pf, 2.5 kv Mica	C1306	.01, +80-20 Z5U
C414	20 pf variable, P. A. Neutralize	C1307	.002, 20% Z5U
C415	20 pf variable, P. A. Tune	C1401	30 pf, 5% DM-15
C416	200 pf variable, P. A. Load	C1402	20 pf, 5% NPO
C417	.001, 20% Z5U	C1403	6-30 pf, Ceramic Trimmer
C418	.001, 20% Z5U	C1404	.01, +80-20 Z5U
C601	50, 5% N750	C1501	.01 mf, 400 v (paper)
C602	10, 5% NPO	C1502	.01, +80-20 Z5U
C603	3.3, 10% QC	C1503	.01, +80-20 Z5U
C604	20 pf, Mica Trimmer (089-003)	C1504	100 pf, 20% N1500
C605	.001, 20% Z5U	C1505	.01, +80-20 Z5U
C606	100 pf, 5% DM-15	C1601	80 mf, 150 v <u>electrolytic</u>
C607	5 pf, +.5 NPO	C1801	270, DM-15 2%
C608	3.3, 10% QC	C1802	470, DM-15 5%
C701	.001, 20% Z5U	C1803	430, DM-15 2%
C702	.001, 20% Z5U	C1804	27, DM-15 5%
C703	120 pf, 5% DM-15	C1805	430, DM-15 2%
C704	220 pf, 5% DM-15	C1806	.01, BG Disc.
C801	27 pf, 5% DM-15	C1807	.002, 20% Z5U
C802	.01, +80-20 Z5U	C1808	.01 Disc.
C803	.01, +80-20 Z5U	C1809	430, 5%

C1810 22, 5% N150
 C1811 15 Var.
 C1812 5 Var.
 C1813 10, N470
 C1814 5 Var.
 C1815 5 pf, N330
 C1816 5-12 VFO Tun.

RESISTORS

All resistors are 1/2 watt rating,
 10% tolerance unless otherwise
 specified.

R101 47 Ohms
 R102 56 Ohms
 R103 47 k - 1 watt
 R104 12 k - 2 watt
 R201 27 k
 R202 27 k
 R203 12 k - 2 watt
 R204 1 k - 1 watt
 R301 100 k
 R302 270 k
 R303 100 Ohms
 R401 1 k
 R402 Selected - 5%
 R403 180 Ohms - 1/2 watt
 R404 10 k - 10 watt
 R405 1 Ohm - 5% - 1 watt
 R406 1 Ohm - 5% - 1 watt
 R407 100 Ohms
 R408 100 Ohms
 R409 10 k - Bias Pot.
 R410 4.7 k - 1 watt
 R411 10 k
 R412 1 k
 R413 10 k
 R601 82 Ohms
 R602 10 Ohms
 R603 10 k - 1 watt
 R701 470 Ohms
 R702 100 k
 R801 10 k R.F. Gain
 R802 470 Ohms
 R803 56 Ohms
 R804 47 k
 R805 1 k
 R901 1 Meg.
 R902 100 k
 R903 100 Ohms
 R904 47 k
 R905 1 k

R1001 10 k
 R1002 270 k
 R1003 1 k
 R1004 100 k
 R1005 270 k
 R1006 270 k
 R1007 2.2 Meg.
 R1008 2.2 Meg.
 R1009 1 Meg.
 R1010 2.7 k
 R1011 100 k
 R1101 470 k
 R1102 1 k
 R1103 47 k
 R1104 120 Ohms - 1 watt
 R1201 1 Meg. A.F. Gain
 R1202 470 k
 R1203 470 k
 R1204 270 k
 R1301 1 k
 R1302 47 k
 R1303 47 k
 R1304 150 k
 R1305 47 k
 R1306 100 k
 R1307 4.7 k
 R1308 5 k Car. Bal.
 R1309 47 k
 R1310 100 k
 R1311 27 k
 R1401 100 k
 R1402 1 Meg.
 R1403 27 k
 R1404 27 k
 R1405 1 k
 R1501 150 k
 R1502 1 k
 R1503 1 Meg. Mic. Gain
 R1504 270 k
 R1505 2.2 Meg.
 R1506 47 k
 R1601 900 ohms - 10 watt
 R1602 800 ohms - 10 watt
 R1603 27 k
 R1604 27 k
 R1605 400 Ohms - 10 watt
 R1606 6 k - 10 watt

DIODES

D401 1N34A Diode
 D1001 1N34A Diode
 D1002 1N34A Diode
 D1601 1N2974A
 D1602 TS-2 Diode

RELAYS

K1 4 PDT Relay, 12 VDC Coil
 K2 2 PDT Relay, 12 VDC Coil

CRYSTALS

Y1401 10,698 kc Car. Osc.

TUBES

V1 6EW6 VFO Amplifier
 V2 12BE6 Trans. Mixer
 V3 6GK6 P.A. Driver
 V4 6146 Power Amplifier
 V5 6146 Power Amplifier
 V6 6HA5 Rec. R.F. Amplifier
 V7 6HA5 Rec. Mixer *4MS*
 V8 6EW6 1st I.F. Amp.
 V9 12BA6 2nd I.F. Amp.
 V10 12AX7 Prod. Det./Rec. A.F.
 V11 6BN8 AGC Amp./Rect.
 V12 6GK6 A.F. Output Amp.
 V13 7360 Bal. Mod.
 V14 12BA6 Carrier Oscillator
 V15 12AX7 Mic. Amplifier
 V16 OA2 Voltage Regulator

TRANSISTORS

Q1 2N706
 Q2 2N706
 Q3 2N706

SWITCHES

S-1 Power On-Off (Part of R801)
 S-2 REC. FUNCTION SWITCH
 S-3 REC. TUNE-CW SWITCH
 S-4 Meter Switch
 S-5 ANL Switch

G. POWER SUPPLIES

GENERAL DESCRIPTION:

The Swan Universal Power Supply systems are designed to provide all necessary voltages required by

designed for an input of 117 volts at 50 or 60 cycles. The model 230-X is identical except that it operates with either 117 or 230 volts. For fixed station use, the 117-X or 230-X is installed in a cabinet which matches the Swan transceivers. This cabinet also contains a speaker, phone jack, and indicator light. The complete combination is designated as model 117-XC or 230-XC. The A.C. line cord plugs into the back of the supply. In the 230-XC, provision for changing from 117 to 230 volts input is made by simply changing line cords. Wiring changes are taken care of in the line cord plug.

12 VOLT OPERATION:

A D.C. Module attaches to the back of the A.C. supply and converts it for 12 volts D.C. input. the

systems, the most common type. (For positive ground systems, the model 14-XP D.C. module is available.) The combined units are designated as model 14-117 or 14-230 depending on which A.C. supply is used. The positive ground models are designated as model 14P-117 or 14P-230.

With the versatility of this power supply design, a number of advantages become apparent. The D.C. supply may be operated from an A.C. line by detaching the D.C. module, making a simple wiring change, and plugging in an A.C. cord. (See instructions under "Mobile Installation.")

The matching A.C. supply, model 117-XC or 230-XC, may be converted easily to 12 volts input by attaching the 14-X D.C. module to the back. This

a 12 volt battery. There may also be times when it will be desirable to operate temporarily in an automobile, such as during a vacation trip, field day, or emergencies. The 117-XC can be set on the floor or front seat, and with the 14-X attached it becomes a 12-volt power supply, complete with speaker.

SPECIFICATIONS:

Power Rating: 200 watts average, 500 watts peak.

Input:

Model 117-X: 117 volts nominal, 50-60 cycles

Model 230-X: 230 volts or 117 volts, 50-60 cycles.

Model 14-X: 13 volts D.C. nominal, 40 amps peak.

Output:

800 volts at 200 ma. average, 600 ma. peak.

275 volts at 150 ma. continuous.

110 volts negative bias, at 100 ma.

12 volts D.C. at 200 ma. relay supply.

only)

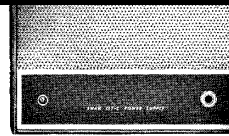

Fig. 6. MODEL 117-XC
AC POWER SUPPLY WITH SPEAKER

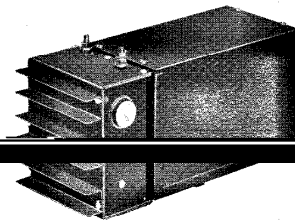

Fig. 7 MODEL 14-117
DC POWER SUPPLY

Battery Drain with Swan Transceiver

Rec: 3.5 amps. Trans: 16 amps average, 40 amps peak (not including filament drain of transceiver).

DESIGN:

Both the A.C. and D.C. sections are conservatively designed for long, reliable service with a minimum failure rate. At the same time, they are designed

for easy access and servicing for those times when it is required. Any component can be readily checked out and replaced in a matter of moments. The D.C. module and A.C. supply can be detached quickly from one another and tested individually, thus isolating the source of trouble.

The A.C. supply is quite conventional, using a silicon rectifier bridge for the medium voltage, and another for high voltage. The 117-X has a single primary winding for 117 volt input, while the 230-X has a pair of primary windings which connect in parallel for 117 volts, and in series for 230 volts. The switching is taken care of in the A.C. line cord plug.

The D.C. module uses two power transistors for switching in a flip-flop oscillator circuit. A large portion of the cost in this unit is in the transistors where no compromise has been made. They are rated at 60 amperes, with a 45 volt rating. A diode snipe clipping circuit provides additional protection

failure.

**MOBILE INSTALLATIONS
READ CAREFULLY**

The 12 volt electrical system in an automobile will sometimes generate high voltage transients. This can be caused by the starter motor, the alternator

serious hazard to the transistors in your DC power supply. By selecting the best transistors available for the application, your Swan supply is capable of absorbing a good deal of abuse, but there is a limit to what even the best transistors can take and for this reason we strongly urge that you read the following notes completely, and follow them carefully.

- (1) Clean and tighten the battery terminals and clamps.
- (2) Tighten battery cables where they attach to the starter solenoid and engine block.
- (3) Inspect battery cables for corrosion or wear. Replace them if they look questionable.
- (4) Check battery condition frequently. If the cells do not hold a similar charge or water level, replace the battery.
- (5) Check alternator, (or generator), and regulator connections for tightness. Also, primary ignition wiring, horn wiring, lights, etc.
- (6) Check the charging voltage from the alternator. Often the regulator is misadjusted, and the voltage setting may be excessive. It should not read more than 14.5 volts at normal engine speeds.

POWER SUPPLY INSTALLATION:

- (A) Connect the primary leads from the power supply directly to the battery terminals. Mount the ceramic fuse block with 50 amp. fuse in series with the positive lead. (With positive ground systems, the fuse goes in the negative lead). If possible, drill and tap a hole in the battery post itself for a contact stud. The more intimately the supply is connected to the battery, the less chance there is for voltage trans-

- (B) The filament line comes prewired to the Jones plug, and has an in-line 9 amp. fuse. Connect this line to the ignition switch accessory terminal, as recommended in the schematic,

initially is switched on while twisting the ignition key to start the engine. Thus, the relay in the power supply will also be turned off, and the transistors will not be subjected to the sharp transients put out by the starter motor. NOTE: The car radio is normally connected to the accessory terminal for the same reason. It may be more convenient to locate the 12 volt

with the transceiver filament line. Look for

SWAN MODEL 14-X D.C. MODULE

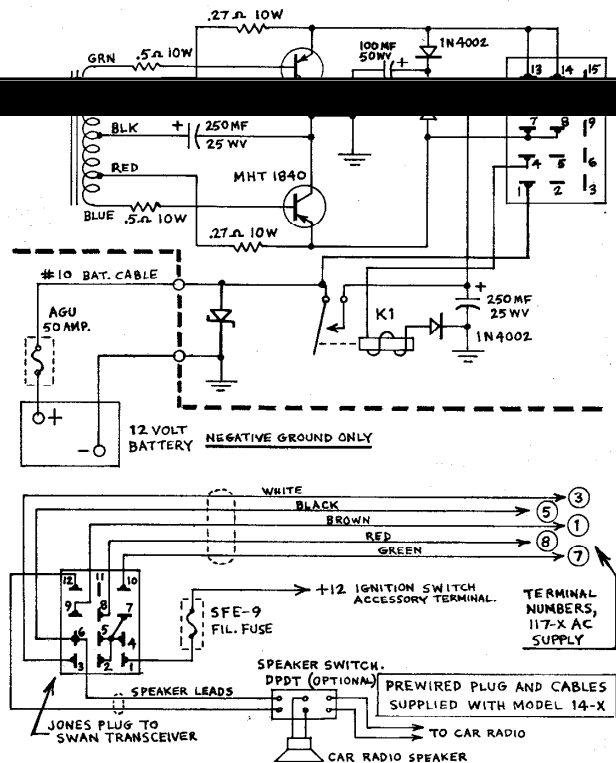

FIG. 8 MODEL 14-X D.C. MODULE

the car radio fuse, and connect to this circuit on the "hot side".

POWER SUPPLY PROTECTION—A Zener diode is installed in the Swan 14-X DC module for added protection. It is an 18 volt Zener which connects across the input terminals of the power supply. It conducts only when the input exceeds 18 volts, thus has no effect on normal operation. Transient volt-

from reaching the transistors. This protection will be effective so long as the diode is operative. If transients reach a high enough level, or a long enough duration, the diode will eventually fail, and literally burn out. After this, the transistors are on

reason. (See Warranty Policy)

SPEAKER CONNECTIONS: Speaker leads coming from the Jones plug go to an under dash speaker, or to a speaker selector switch which may be installed as illustrated. Another arrangement which works well is to install a rear seat speaker for the

to the transceiver.

SWAN MODEL 117-X (230-X) A.C. POWER SUPPLY

Handwritten: 10-1

Handwritten: added 10-1

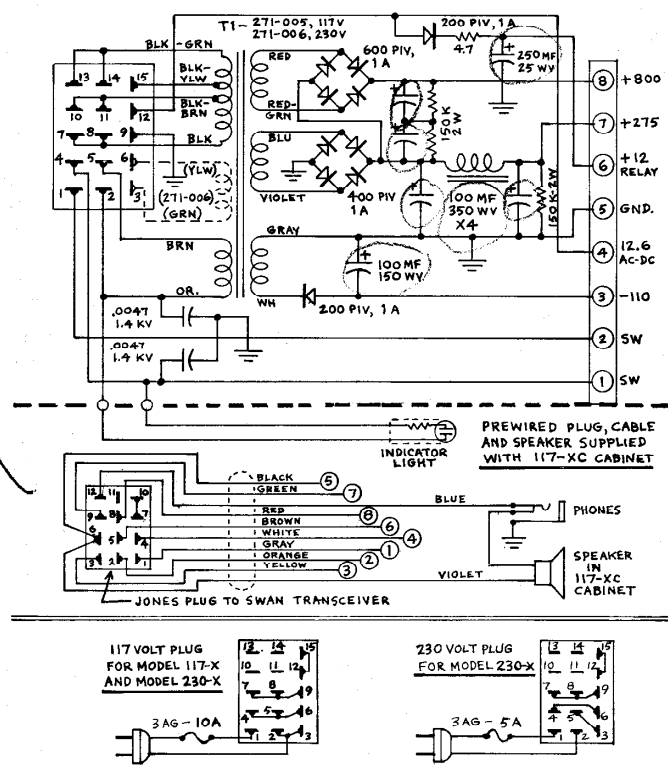

FIG. 9 MODEL 117-X (230-X) POWER SUPPLY

A.C. OPERATION: The 12 volt power supply may be operated from an A.C. line by two methods.

- (A) Detach the D.C. Module, and plug in an A.C. line cord in place of it. Before applying power, disconnect the brown cable wire going to terminal (1) of the A.C. supply and connect a jumper from terminal (1) to (2). Temporarily tape the brown wire to keep it from shorting to ground, since it will be carrying 12 volts D.C. Now the power supply will operate when the A.C. line is plugged in, although the transceiver filaments will still be operating on the battery. This arrangement will be useful primarily for checking out the A.C. portion of the supply when trouble shooting.
- (B) To operate the transceiver entirely on the A.C. line, it will be necessary to do the following: Disconnect the 5 wire cable going from the the transceiver to the A.C. portion of the sup-

emergency operation from the car when A.C. power is available.

If frequent A.C. as well as D.C. operation with the mobile supply is contemplated, both the 5 wire and 10 wire cables may be connected simultaneously to the supply. Thus, when operating on D.C., the 5 wire cable is plugged into the transceiver, and on A.C. operation the 10 wire cable is used.

MATCHING CABINET:

Ordinarily the A.C. supply will be purchased complete in a matching cabinet as either model 117-XC or 230-XC. However, in some cases an owner may have purchased a 117-X or 230-X basic supply only perhaps in a D.C. supply combination and he may wish later on to mount it in a matching cabinet. For this purpose the cabinet with speaker and cables is available separately. The basic A.C.

cable and hook-up as illustrated in the schematic diagram Fig. 9. This is the same cable and speaker hook-up used in the matching cabinet, 117-XC. Using the D.C. supply in this manner will prove useful for portable or

wired cable connects as shown in the schematic. Connections to the phone jack and speaker have already been made. Two leads from the indicator light must be run through the grommet and soldered to the terminals provided at the bottom of the

supply. Refer to the schematic for clarification. The A.C. line cord is also provided with the matching cabinet kit. These line cords are available separately also, and come normally wired and stamped for 117 volts. 230 volt line cords are also available on special order, or the 117 volt line cord may easily be wired for 230 volts by referring to the schematic. Note that the 230 volt line cord will work only with the 230-X basic A.C. supply. The 117 volt line cord will work with either the 117-X or 230-X.

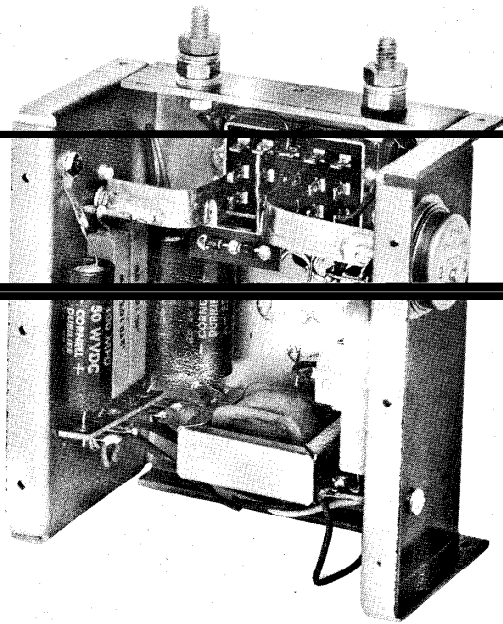

FIG. 10 MODEL 14-X, D.C. MODULE
INTERNAL VIEW

POWER SUPPLY

WARRANTY POLICY—The normal guarantee on your Swan power supply is for a period of 90 days from date of purchase, and covers all components, material and workmanship. In the case of transistor failure, however, the warranty on them will be void if inspection proves that high transient voltages from the automobile were responsible. We will do all in our power to be fair and just in this determination. The warranty card must be filled out and mailed to the factory within 10 days from date of purchase. Do not ship a unit to the factory for servicing without prior authorization. Check with your dealer first, as he may be in a position to handle the service work more quickly. This warranty is void if the equipment has been misused or damaged.

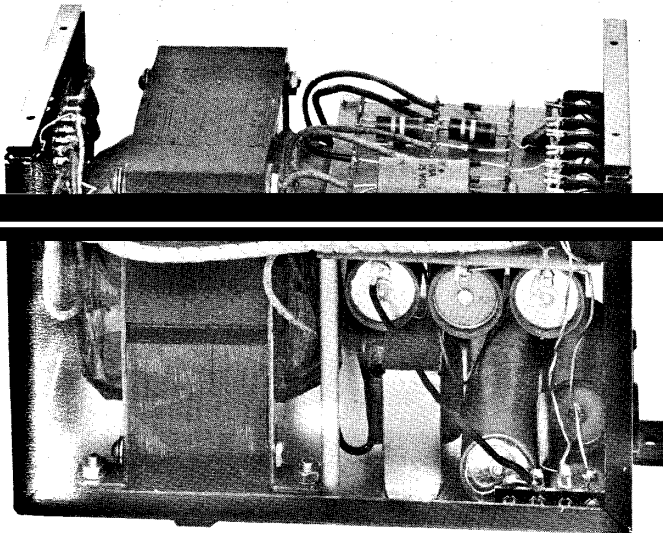
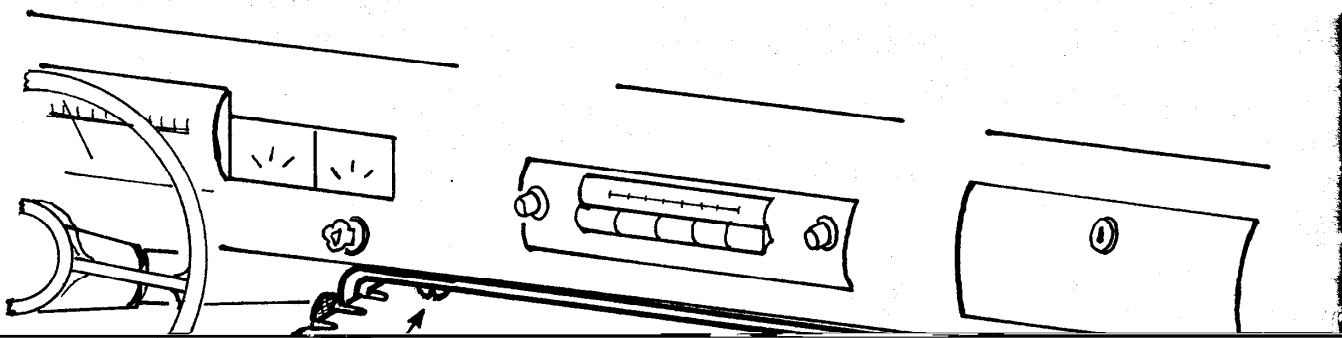

FIG. 11 MODEL 117-X BASIC AC POWER SUPPLY
INTERNAL VIEW



Secure mounting bracket to under side of dash with large sheet metal screws.

Locate the best cabinet slot for mounting, and attach hardware as illustrated

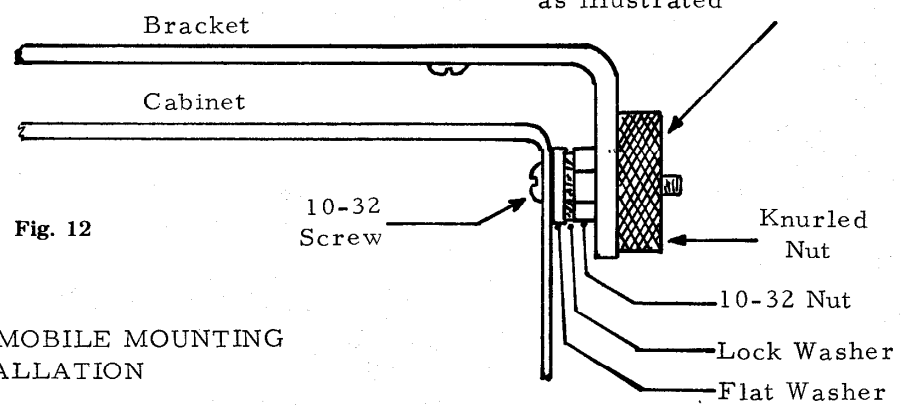
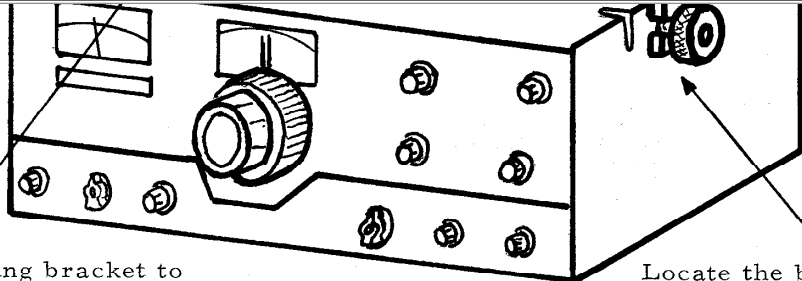
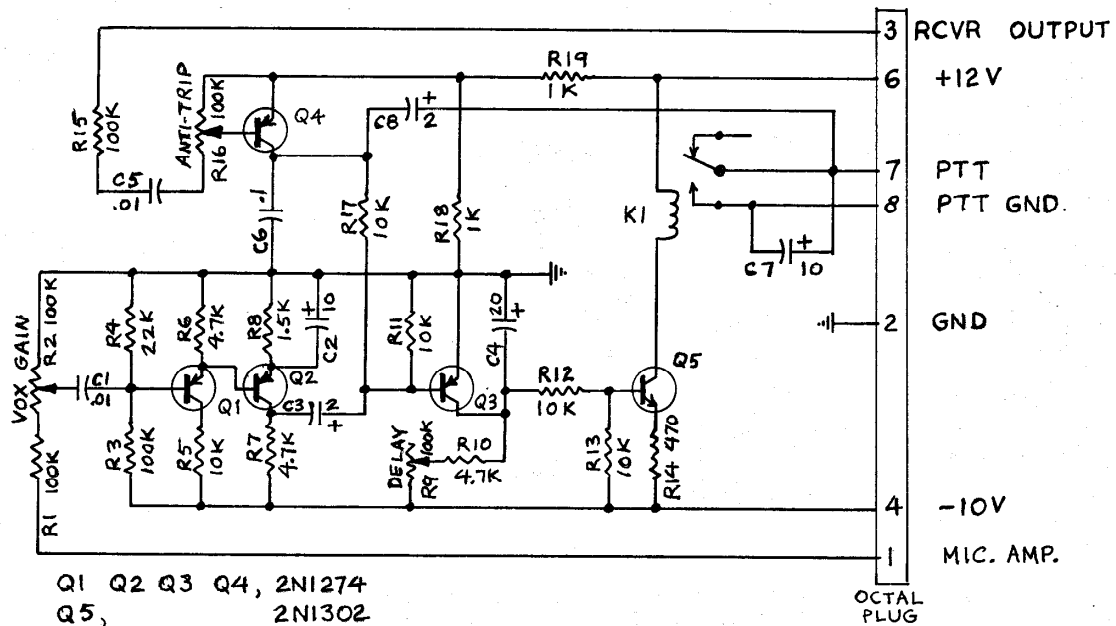

Fig. 12

TYPICAL MOBILE MOUNTING INSTALLATION



8-3-65

Fig. 13 PLUG IN VOX ACCESSORY, MODEL VX-1

OPERATING INSTRUCTIONS

1. Place the VOX-PTT switch in the PTT position and adjust the transceiver for normal push-to-talk operation.
2. Plug in the VX-1 and rotate the VOX GAIN, ANTI-VOX, and DELAY controls fully counter-clockwise. Attach the top of the VX-1 to the 350 back with a G-32 screw.
3. Rotate the transceiver MIC. GAIN fully counter-clockwise. This will prevent audio from being transmitted but will not affect VX-1 during initial adjustments.
5. Place the VOX-PTT switch in the VOX position.
6. While speaking into the microphone in a normal manner, slowly rotate the VOX GAIN control clockwise until the VX-1 keys the transmitter. Do not use more VOX GAIN than necessary to assure positive operation at normal voice levels.
7. Increase the receiver gain until received signals are at a normal volume level. These

signals will trip the Vox when picked up by the microphone.

8. With the microphone held in the normal operating position, very slowly increase the ANTI-VOX until received signals do not trip the Vox.

NOTE: Excessive ANTI-VOX gain will cause received signals to gate the VX-1 off so that no amount of sound at the microphone will key the transmitter. Satisfactory balance between the VOX GAIN and ANTI-VOX is easily obtained when the microphone is at least a foot from the speaker.

9. Adjust the DELAY control to hold the transmitter keyed for the desired interval after you stop talking.

NOTE: A little experimenting on the air will reveal that only a small portion of the first spoken syllable is lost when the VX-1 is actuated. Short DELAY settings will result in most efficient operation.

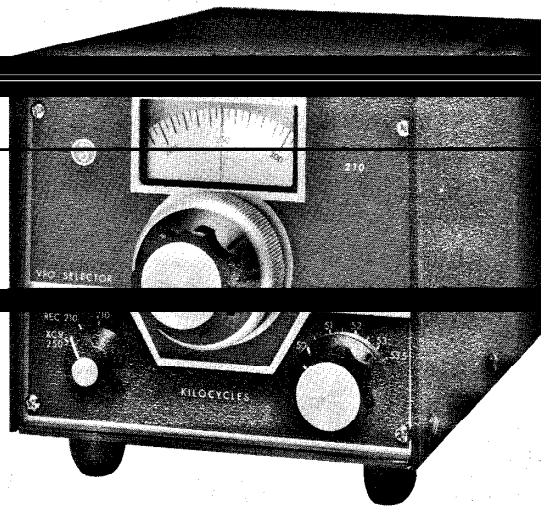

SWAN MODEL 210 FREQUENCY CONTROL UNIT

SWAN MODEL 210 FREQUENCY CONTROL UNIT

Model 210 Frequency Control Unit is designed for full coverage of the 50-54 mc band when used with the model 250 transceiver. The unit matches the 250 in height, depth, and styling. Telay switching is built-in, and a selector knob on the front panel provides for selection of frequency control. In position 1 the VFO in the 250 is used for both transmit and receive. In position 2 the 250 VFO is used for transmit and the external 210 VFO is used to receive. In position 3 the 210 VFO is used for both transmit and receive.

An adaptor socket must be installed on back of the 250 transceiver to accommodate the 210. This adaptor socket and installation kit is included with the 210. See page 24 for details.

CIRCUIT THEORY

Q1, the 2N706 Oscillator operates in the common base configuration, as a Colpitts oscillator. See Figure 6. Capacitors C1801, C2001, and C2003 effectively tap the oscillator across only about 10 percent of the tank circuit. This results in exceptional stability. Q2, the Emitter Follower, is used for matching the impedance of the coaxial cable to the transceiver, as well as for isolation. The KC tuning dial provides vernier tuning over a 0 to 500kc range, and the MC dial is adjusted to cover the desired range.

ALIGNMENT

For frequency calibration of the model 210 external oscillator, refer to page 11 for instructions on calibration of the internal VFO in the model 250 transceiver. The same procedure applies to the model 210. Actual oscillator frequency is listed in the accompanying chart.

Transceive Frequency	Injection Freq. From VFO Amp.	Oscillator Frequency
49.5 MC	38,802 KC	12,934.0 KC
50.0	39,302	13,100.6
50.5	39,802	13,267.3
51.0	40,302	13,434.0
52.0	41,302	13,767.3
53.0	42,302	14,100.6
54.0	43,302	14,434.0

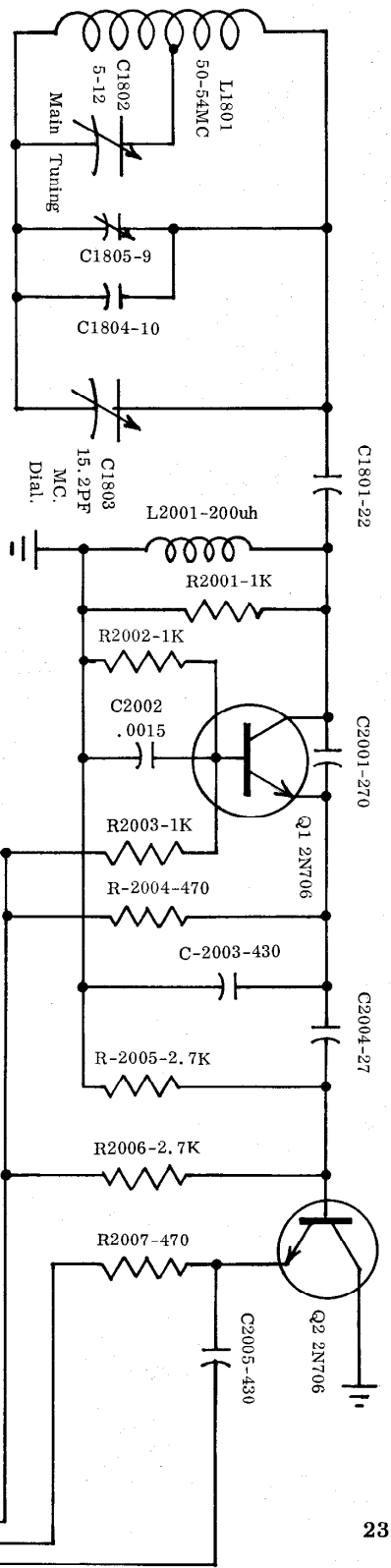

Circuit Board Mounted Components

R2001	1K, 5%, 1/2 Watt	C2001	270, 2%, Silver Mica
R2002	1K, 5%, 1/2 Watt	C2002	.0015 Ceramic Disc
R2003	1K, 5%, 1/2 Watt	C2003	430, 2%, Silver Mica
R2004	470, 5%, 1/2 Watt	C2004	27, 5%, Silver Mica
R2005	2.7K, 10%, 1/2 Watt	C2005	430, 5%, Silver Mica
R2006	2.7K, 10%, 1/2 Watt	C2006	.01 Ceramic Disc
R2007	470, 5%, 1/2 Watt	L2001	200 UH RFC

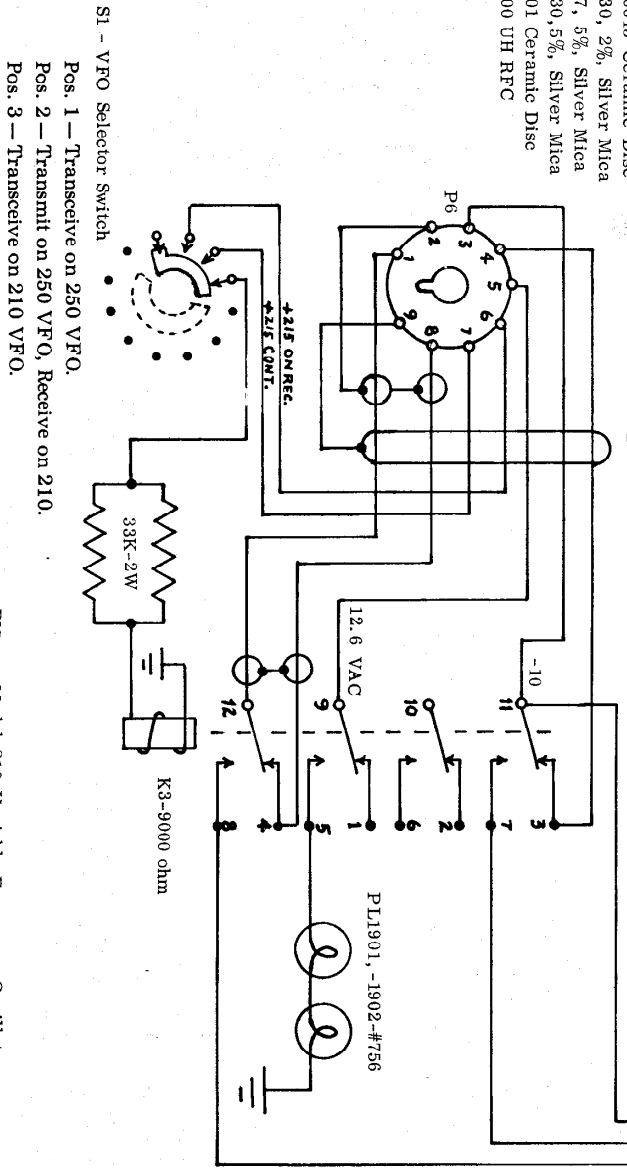

- SI - VFO Selector Switch
- Pos. 1 - Transceive on 250 VFO.
- Pos. 2 - Transmit on 250 VFO, Receive on 210.
- Pos. 3 - Transceive on 210 VFO.

FIG. 14 Model 210 Variable Frequency Oscillator

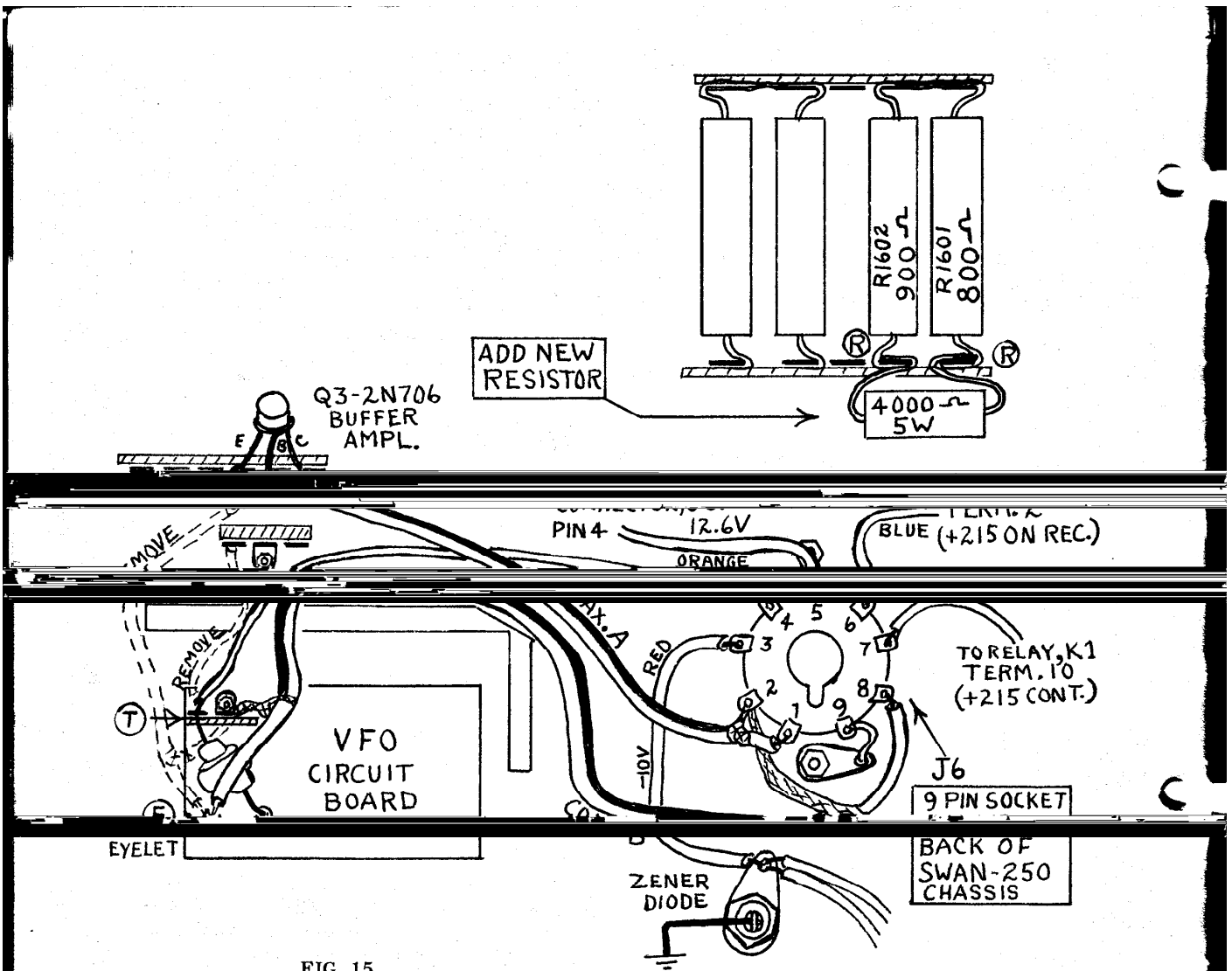
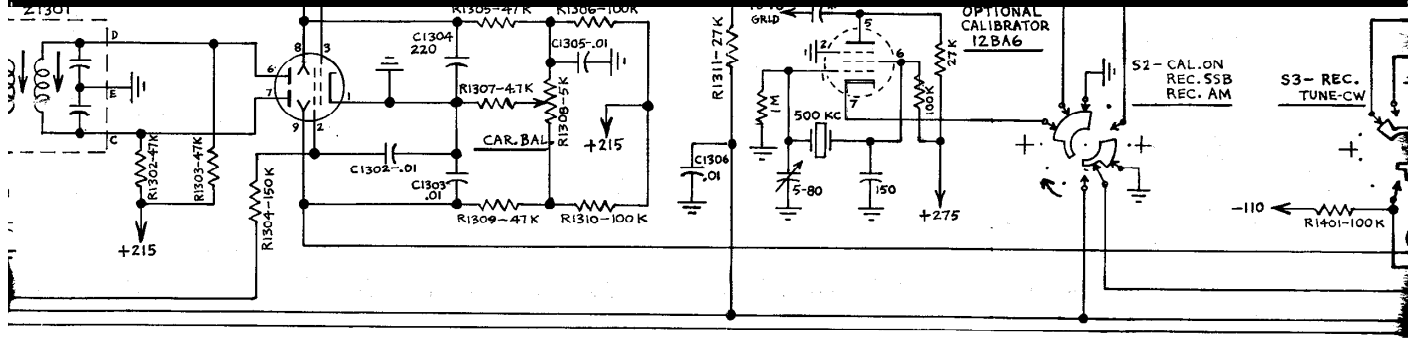
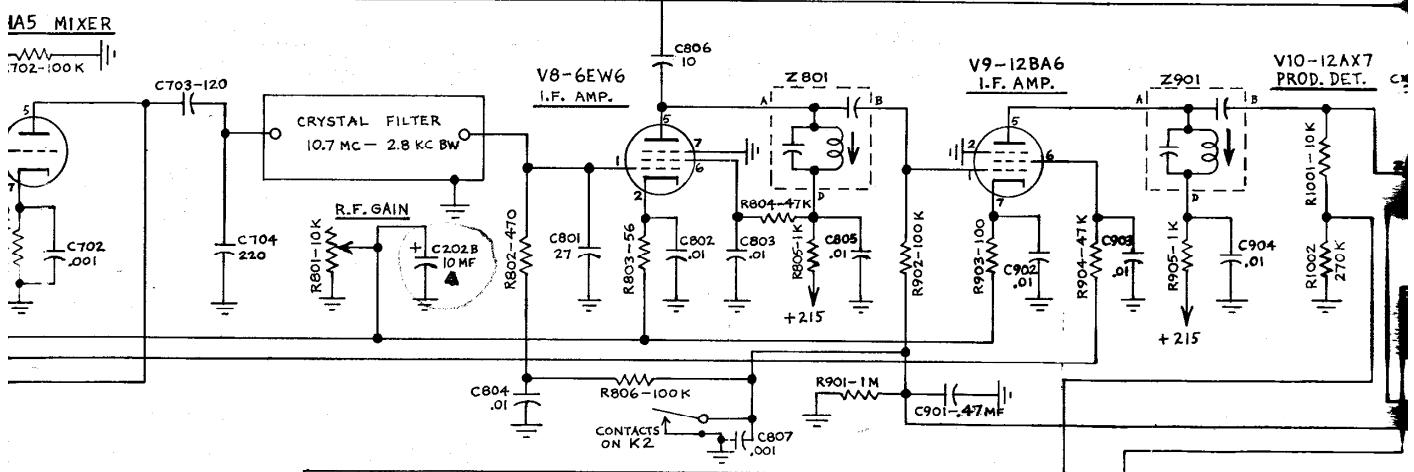
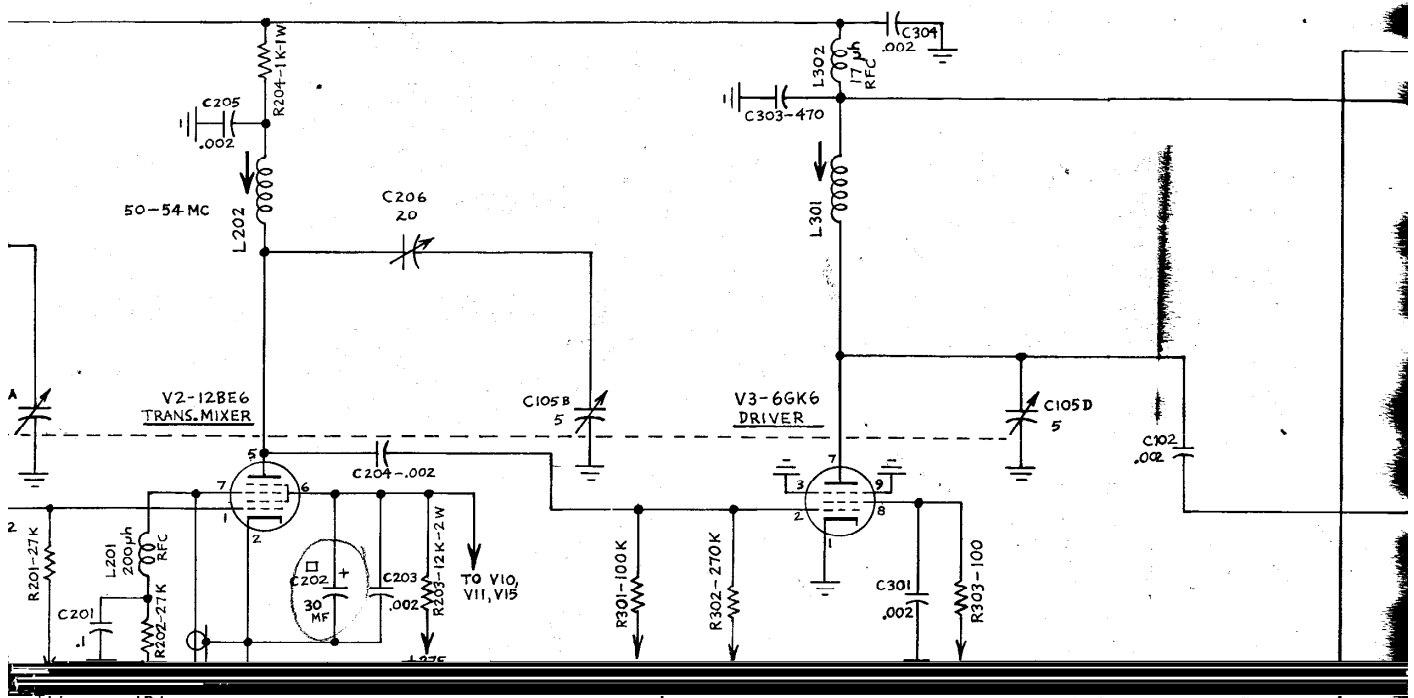

FIG. 15

MODIFICATION INSTRUCTIONS, for installation of Model 210 outboard VFO socket in Swan 250 Transceiver.

1. Install the pre-wired socket in the accessory location on the back of the 250. Be sure to secure the mounting screws tightly.
2. Remove coax. running from eyelet "E" of the VFO circuit board to base terminal of Q3. Connect center conductor of new coax. "A" to base terminal of Q3, and its shield to ground lug, as illustrated.

3. Connect center conductor of new coax. "B" to eyelet "E" of VFO circuit board. Connect its shield to ground lugs as illustrated.
4. Remove and discard the wire lead going to term. lug "T" on the circuit board, and connect the new gray wire to lug "T".
5. Connect the Red, Orange, Blue, and Green leads as illustrated.
6. Connect the new 4000 ohm 5-watt resistor to term. lugs R- R as illustrated.
7. The Model 210 VFO may now be plugged into J6.



SCHEMA

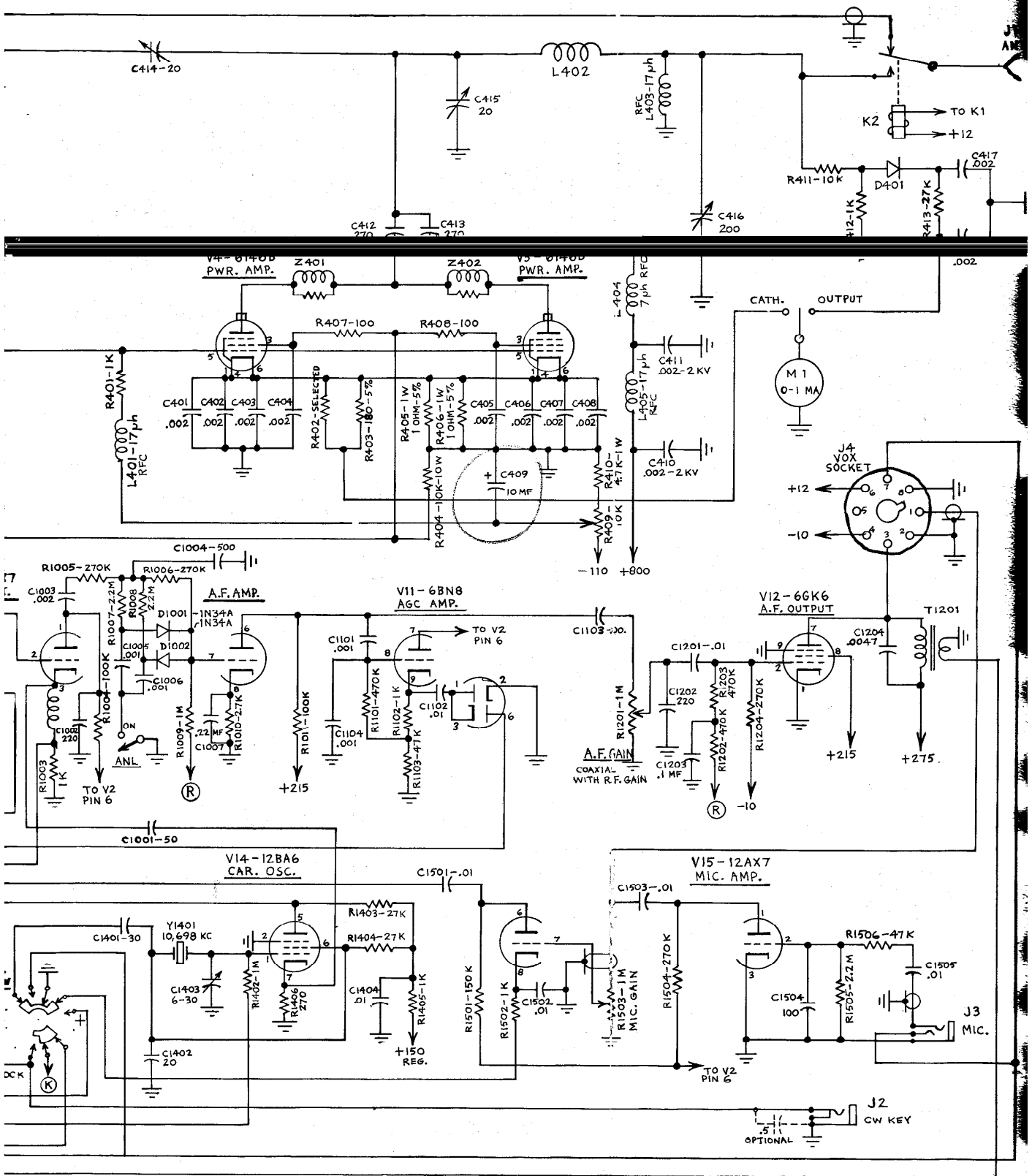

SCHEMATIC DIAGRAM, SWAN MODEL 250, SIX METER SSB TRANSCEIVER

