

STANDARD FORM WARRANTY

ADOPTED BY THE RADIO MANUFACTURERS ASSOCIATION, INC.

This equipment is warranted to be free from defective material and workmanship and repair or replacement will be made of any part which under normal installation, use and service discloses defect, provided the unit is delivered by the owner to the manufacturer or through the authorized radio dealer or wholesaler from whom purchased, intact, for examination, with all transportation charges prepaid to the factory, within ninety days from the date of sale to original purchaser, and provided that such examination discloses in the manufacturer's judgement that it is thus defective.

This warranty does not extend to any radio products which have been subjected to misuse, neglect, accident, incorrect wiring, improper installation, or to use in violation of instructions furnished by the manufacturer, nor extend to units which have been repaired or altered outside of the factory, nor to cases where the serial number thereof has been removed, defaced or changed, nor to accessories used therewith of other manufacture.

Any part of a unit approved for remedy or exchange hereunder will be remedied or exchanged by the authorized radio dealer or wholesaler without charge to the owner.

This warranty is in lieu of all other warranties expressed or implied and no representative or person is authorized to assume for the manufacturer any other liability in connection with the sale of their radio products.

National Company, Inc. reserves the right to make any change in design or to make addition to, or improvements in, its products without imposing any obligations upon itself to install them in its products previously manufactured.

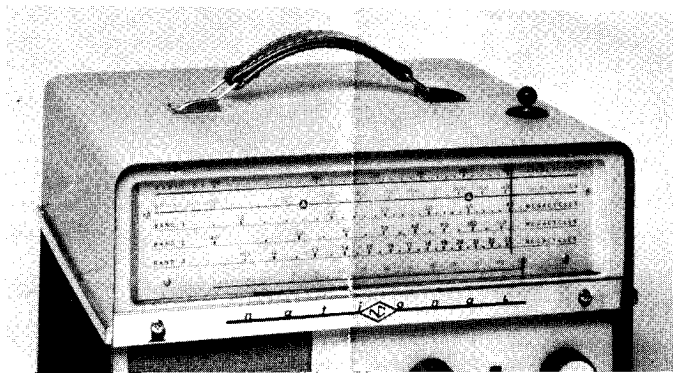

SECTION 2. INSTALLATION

2.1 UNPACKING

The packing materials for the NC-66 have been carefully designed to minimize the possibility of injury to the equipment under normal shipping and handling conditions. To prevent damaging the receiver when removing it from its carton the procedure outlined below should be followed:

- a. Remove the slotted top insert. This will expose the carrying strap.
- b. Using the carrying strap, lift the NC-66 from the carton.
- c. The protective wraparound insert will come out of the carton with the receiver. This insert is easily removed by holding it stationary and lifting the receiver free by the carrying strap.

Each NC-66 is carefully inspected and tested before leaving the factory and should be ready to put into operation immediately. However, upon unpacking, check all controls, switches, and the telescoping rod antenna for proper operation.

2.2 INITIAL SETUP

In most cases the antenna supplied with the NC-66 will give excellent results, however, if it is desirable to use an external antenna for fixed short-wave reception, antenna terminals are provided at the rear of the



chassis as illustrated in figure 2-1. Figure 2-2 illustrates a typical external antenna hookup for use with the NC-66. The lightning arrester and ground connection shown in this diagram are optional. If an external antenna is only to be used temporarily, it may be clipped to the telescoping antenna and thus may be easily removed.

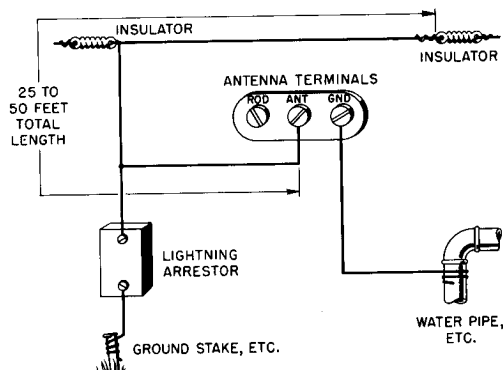

Figure 2-2. Typical External Antenna Hookup

Power requirements for fixed operation are 115 volts ac or dc, or, 220 volts ac when used with the NC-66/VA220A adaptor. Since a selenium rectifier is used the NC-66 may fail to operate when first plugged into a 115 volt dc source. Should this situation arise, simply reverse the plug to establish the correct

receptacle at the rear of the chassis as illustrated in figure 2-1. This action automatically changes the position of the power conversion switch. The following type batteries, or their equivalents are recommended for use with the NC-66:

Burgess type F6A60P
Eveready type 757
General type 273
Ray-O-Vac type AB909
R.C.A. type VS058



SECTION 3. OPERATION

3.1 CONTROLS

All controls and indicators required to operate the NC-66 are located on the front panel. The diagram on the following page, figure 3-2, shows the physical location of the controls and switches and gives a short functional description of each part.

The short warmup time of the low-filament-voltage tubes used in the NC-66 makes it possible to combine the on-off and standby-receive switches of conventional receivers in one ON-REC OFF-STBY switch. When in the OFF-STBY position, all power is removed from the circuits and, in the ON-REC position, power is supplied to the circuits and the receiver is ready for immediate use.

3.2 OPERATING PROCEDURES

For voice or music reception set the NC-66 switches and controls as follows:

| | |
|---------------------------|---|
| ON-REC OFF-STBY Switch | REC |
| CW-OFF Switch | OFF |
| BANDSPREAD BAND | SET Set for the frequency range to be tuned |
| VOLUME | Set for comfortable listening level |

For code reception set the CW-OFF switch to its CW position. The operation and function of all other controls and switches are the same for code or voice reception.

3.3 TUNING

The calibration of the general coverage scales, figure 3-1, is most accurate when the bandspread pointer is in the SET position. The general coverage dial scales are slide-rule type and are calibrated in KILOCYCLES and MEGACYCLES. The CONELRAD

REMOVES ALL POWER FROM CIRCUITS WHEN
IN THE OFF-STBY POSITION. USE AS A
STANDBY SWITCH IS POSSIBLE SINCE THE

ACTIVATES A FEEDBACK
CIRCUIT IN THE IF AMP-
LIFIER (V3) CAUSING IT TO

| BAND | 17 METER | 19 METER | 25 METER | 31 METER | 49 METER |
|--------------------|------------------------------|-------------------|-------------------------|------------------|-------------------------------|
| FREQUENCY RANGE | 17.7 - 17.9 | 15.1 - 15.45 | 11.7 - 11.95 | 9.5 - 9.8 | 6.0 - 6.2 |
| SUNRISE TO NOON | EASTERN STATIONS GOOD | SAME AS 17 METER | WEST & SOUTHWEST | SAME AS 25 METER | SAME AS 25 METER |
| NOON TO SUNSET | SOUTH GOOD | EAST & SOUTH GOOD | SAME AS 19 METER | EAST GOOD | MOST SIGNALS WEAK |
| SUNSET TO MIDNIGHT | STATIONS FADE BAND GOES DEAD | SAME AS 17 METER | EAST FADES SOUTH STRONG | SAME AS 25 METER | NORTH, SOUTH & EAST VERY GOOD |

Figure 3-3. Short-Wave Listening Schedule

frequencies at 640 kc and 1240 kc are marked with the civil defense symbol . The Amateur Bands from 160 meters to 15 meters are underlined in black while the principle foreign short-wave bands are underlined in red. The TUNING control is used to adjust the General Coverage dial settings.

The Bandsread scale is calibrated in red from zero to 100 (SET). To use the BANDSPREAD feature of the NC-66, set the General Coverage dial pointer to the high end of the range to be spread and adjust the BANDSPREAD control to the desired setting. For example, if the operator wishes to "bandsread" tune the 80 meter Amateur band the General Coverage pointer would be set at 4.0 mc on BAND 1. The "bandsread" tuning would then spread the 80 meter band, 3.5 to 4.0 mc, over the entire length of the Bandsread tuning scale.

3.4 SHORT-WAVE LISTENING

Bands 1, 2 and 3 are the high frequency or short-wave bands. The frequencies covered by these bands, 1.4 to 23 mc, are those used by the principle foreign, commercial, and amateur radio stations all over the world. There are over a million and a half radio transmitting stations in operation today, most of which transmit signals within the frequency range of the NC-66.

The principle short-wave transmitting stations operate on five major bands and two minor bands. One characteristic of short-wave is that reception will be good on some bands at certain times of day, and, at the same time, poor on other bands. Figure 3-3 shows the major short-wave broadcast bands, their frequencies, and their approximate operating characteristics at certain times of day.

NOTE

There is no power switch on the VOLUME control of the NC-66. The receiver is turned off by placing the ON-REC OFF-STBY switch in the OFF-STBY position.

SECTION 4. SERVICE

4.1 GENERAL

The information contained in this section will aid qualified radio service personnel in repairing and aligning the NC-66

| | | |
|-----|-----|-----------------------------|
| V-1 | 1U4 | RF Amplifier |
| V-2 | 1L6 | Local Oscillator, Mixer |
| V-3 | 1U4 | IF Amplifier, CW Oscillator |
| V-4 | 1U5 | Detector, Audio Amplifier |
| V-5 | 3V4 | Audio Output Amplifier |

4.2 REMOVING THE CHASSIS

The telescoping rod antenna is mounted in such a manner that its first section passes through a hole in the chassis. Therefore, the rod antenna must be removed before the chassis can be taken out of the cabinet. The lead from the rod antenna is terminated with a spade-lug that is connected to the antenna terminal marked "ROD". The rod antenna is held in place by a plate which is screwed to the bottom of the cabinet. To remove the rod antenna, disconnect the lead from the "ROD" terminal, remove the two hex-head drive screws holding the plate to the bottom of the cabinet, and carefully slide the antenna downward out of the cabinet. After the rod antenna is removed, the chassis may be taken out of the cabinet by sliding off the four knobs on the front panel and removing the four remaining hex-head drive screws at the bottom of the cabinet.

4.3 CIRCUIT ANALYSIS

The NC-66 circuit uses five vacuum tubes and a selenium rectifier. The vacuum tubes are identified by reference symbols V1 through V5 on the schematic diagram in the back of this manual. These vacuum tubes and their functions are as follows:

4.4 ALIGNMENT

The following test equipment is necessary to align the NC-66:

- a. An AM Signal Generator having:
 1. 30% 400 cycle modulation (AM)
 2. Frequency range of 200 kc to 20 mc
- b. An output meter
- c. An isolation transformer.

Alignment of the IF section may be accomplished by feeding a 455 kc signal across the middle band-spread capacitor stator and tuning the top and bottom slugs T1 and T2 for maximum output.

The following illustrations are included in this manual as service aids:

- Figure 4-1 RF Alignment Chart
- Figure 4-2(A-B) Dial Stringing Diagrams
- Complete Schematic Diagram



RF ALIGNMENT CHART

| BAND | DF | BC | NO.1 | NO.2 | NO.3 |
|-----------------------|--------------------------------|--------------------|-------------------------|-------------------------|----------------------------------|
| NOTE | BC MUST BE ALIGNED FIRST | | | | NO.2 MUST BE ALIGNED FIRST |
| SET GENERATOR | 200 KC | 550 KC | 1.5 MC | 4.5 MC | 12 MC |
| SET MAIN TUNING | 200 KC | 550 KC | 1.5 MC | 4.5 MC | TO SIGNAL |
| ADJUST TO TUNE | DF OSC COIL | BC OSC COIL | NO.1 OSC COIL | NO.2 OSC COIL | |
| ADJUST FOR MAXIMUM | DF MIXER COIL | BC MIXER COIL | NO.1 MIXER COIL | NO.2 MIXER COIL | NO.3 MIXER COIL |
| ADJUST FOR MAXIMUM | DF ANTENNA COIL | BC ANTENNA COIL | NO.1 ANTENNA COIL | NO.2 ANTENNA COIL | NO.3 ANTENNA COIL |
| SET GENERATOR | 350 KC | 1200 KC | 3.5 MC | 10 MC | 20 MC |

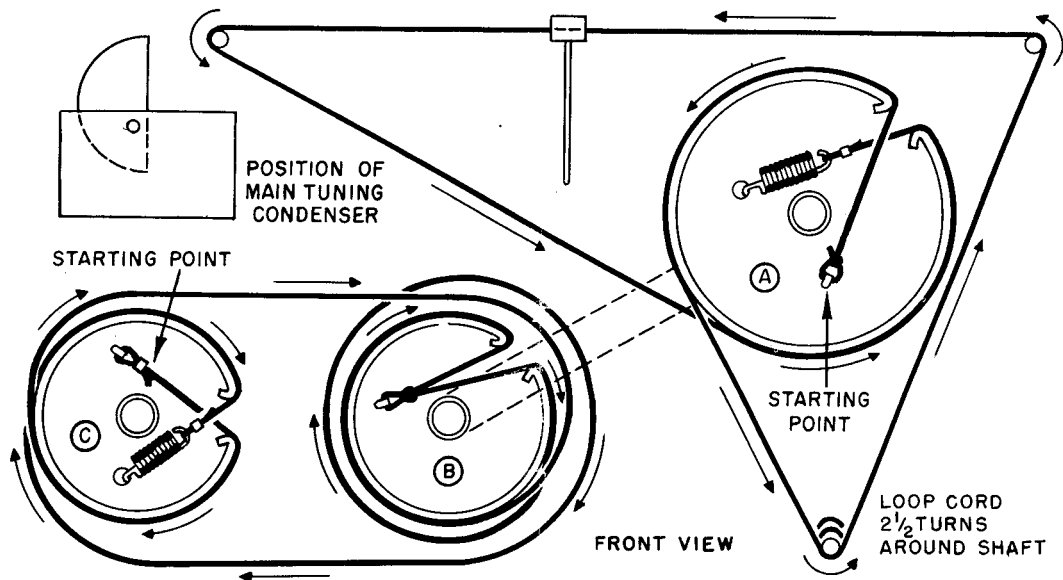
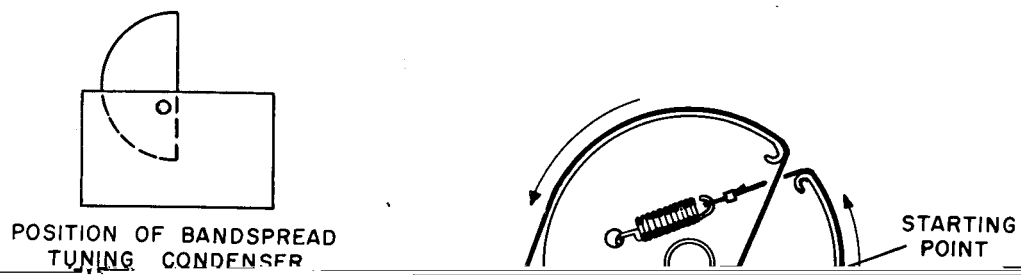

Figure 4-2A. General Coverage Dial Stringing Diagram



SECTION 5. ACCESSORIES

5.1 RDF-66 ADAPTOR

The RDF-66, which is shown in figure 5-1, is a modern, efficient, radio direction finding instrument designed for use with the NC-66 receiver to provide a simple means of navigation for pleasure craft and small fishing vessels.

Detailed information on the RDF-66 adaptor may be obtained from National Company Incorporated, 61 Sherman St., Malden 48, Mass.

5.2 NC-66/VA220V ADAPTOR

The NC-66/VA220V adaptor, as illustrated in figure 5-2, is designed to enable the NC-66 receiver to operate from a 220 volt ac power source. A step-down transformer and three-pin plug mounted on a phenolic board make up the adaptor. When installed in the receiver, the NC-66/VA220V is plugged into J-3 in place of P-3 (see schematic diagram). Two self-tapping screws are supplied with the adaptor to lock it in position. Holes are provided in the adaptor mounting board and in the chassis to receive these screws.

NOTE

Once the NC-66/VA220V adaptor has been installed only 220 volts ac or battery power may be used.



Figure 5-1. RDF-66 Adaptor

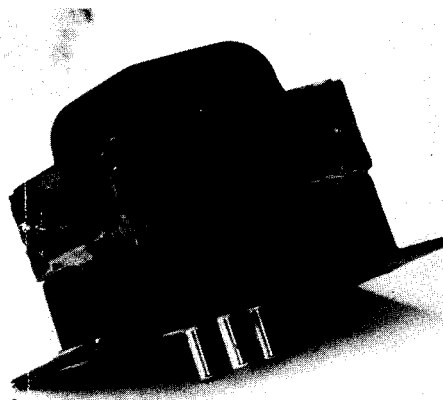

Figure 5-2. NC-66/VA220V Adaptor



5000ER494
R&S2/57

Don't Tell...

