

DESCRIPTION AND OPERATION



FIG. 1 THE NC-270

The National NC-270 receiver is designed to match an unbalanced 70Ω antenna and transmission line. Individual antenna coils are used on each band. The impedance match is obtained by use of a small primary coupling winding on the antenna coil with the exception that on the 6 meter band, the impedance match is obtained by means of a tap on the antenna coil.

The rear apron of the NC-270 is illustrated in Figure No. 2. The NC-270 incorporates two methods of antenna connection, a small coaxial jack for use when shielded types of lead-in are used, and a two terminal antenna strip suitably marked A and G for use where individual lead wires are employed. The simplest antenna is a single long wire antenna illustrated in Figure No. 3. When an antenna of this type is used, a suitable ground connection is recommended for best results. Generally speaking, an antenna between 15 feet and 40 feet long should provide ample signal pick-up for most of the amateur bands in use. When the receiver is to be used predominantly on any one band, better results can always be obtained with one of the many types of tuned antennas. The common doublet or half-wave antenna is illustrated in Figure No. 4

and may be connected to the receiver antenna terminals by connecting one of the lead wires to the antenna terminal, the other to the ground terminal, although more satisfactory results will generally be obtained if a suitable balanced to unbalanced transformer type coupling is used. Many other types of antenna configurations are available and beneficial under various reception conditions. The subject of antennas and the matching of antennas to receivers is in itself a major study. The owner of the NC-270 should consult many of the excellent references published by the American Radio Relay League and other organizations. In all cases where an external exposed antenna is employed, suitable consideration should be given to lightning protection for the sake of insuring safety to the operator and to the equipment.

THE ANTENNA

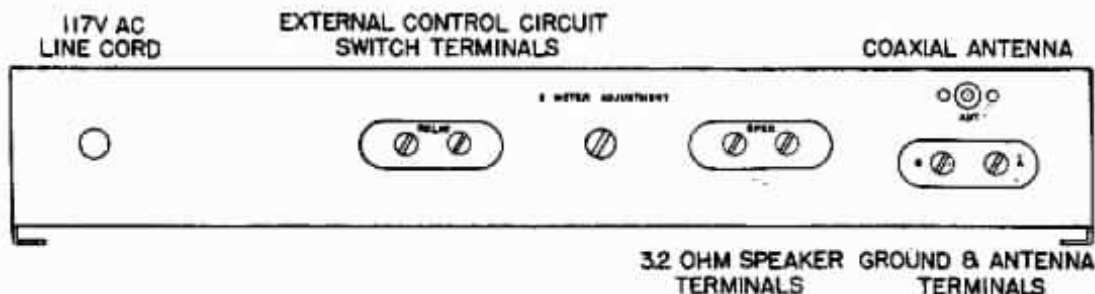

FIG. 2 THE REAR APRON



ANTENNA

maximum background noise earphones. It should not be necessary to repeat the antenna settings on the same antenna if the bandwidth is used to select the desired signal. In this case, it is necessary that the antenna be tuned for the newly selected

the tuned circuit of the antenna through a capacitor to the grid of the 6BE6 as the RF stage of the receiver. The gain control (AGC) voltage is used in order to adjust the gain of the receiver suitable for the strength of the signal.

The tuned circuit of the RF stage is connected to the antenna through a capacitor to the grid of the 6BE6 as the RF stage of the receiver. The gain control (AGC) voltage is used in order to adjust the gain of the receiver suitable for the strength of the signal. The secondary of the tuned circuit is connected to the grid of the 6BE6 as the RF stage of the receiver. The gain control (AGC) voltage is used in order to adjust the gain of the receiver suitable for the strength of the signal.

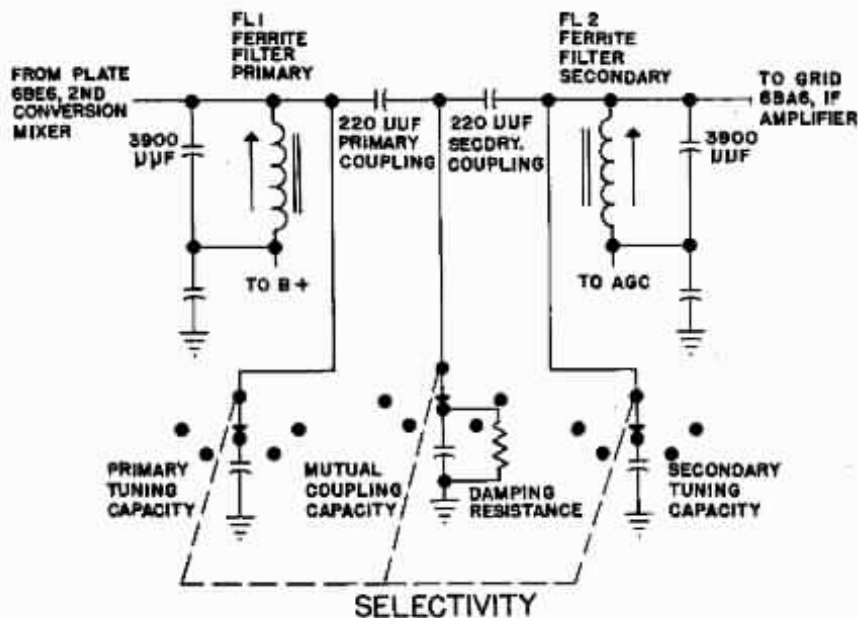

FIG. 5 FERRITE FILTER SIMPLIFIED SCHEMATIC DIAGRAM

A grounded plate "Hartley" oscillator circuit is used for purposes of signal conversion to the first IF frequency. This oscillator is a part of the 6BE6 first converter tube. As before, the proper oscillator coil is selected by the bandwidth and tuning of the oscillator tank circuit is accomplished by means of the main tuning capacitor and the alignment trimmer C15. In order to obtain a high degree of stability in the oscillator, a special zero temperature coefficient ceramic capacitor C16 is used to form the predominant portion of the tuned circuit. In addition, a small negative temperature compensating capacitor C18 is used to compensate for the positive temperature coefficient of the coils. This combination of parts results in temperature stability of the NC-270 receiver which will surprise even the most experienced operator. The oscillator frequency is always 2215 KC above the signal frequency to which the receiver is tuned, thus generating a 2215 KC first IF signal. This signal is fed from the plate of the 6BE6 first converter to a conventional double tuned IF transformer which serves as the interstage coupling between the first and second converters. Signal coupling is accomplished by means of the mutual inductance between the primary and secondary of this interstage transformer and the resulting signal is applied to the signal grid of the 6BE6 second converter tube. The selectivity of this first IF circuit

provides excellent secondary IF image rejection and, at the same time, is high enough in frequency to provide excellent primary image rejection which results from the tuned antenna and mixer circuits. The second converter oscillator is a crystal controlled modified "Colpitts" circuit using the screen of the 6BE6 converter as a grounded plate. This second IF oscillator frequency is set at 2445 KC which beats with the 2215 KC signal to produce a 230 KC IF output frequency.

The 230 KC IF signal is coupled from the plate of the 6BE6 second converter tube to the patented Ferrite Filter. Figure No. 5 illustrates a simplified diagram of the Ferrite Filter circuit which employs 2 tuned circuits with "Q" of the individual coils running approximately 500. The 2 tuned circuits are impedance coupled one to the other with the selectivity switch performing the function of changing the coupling impedance and damping to achieve variations of bandwidths from the narrow 600 cycle position to the wide 5 KC position. In addition to changing the degree of coupling and damping, in the upper and lower single sideband positions the actual resonant frequency of the primary and secondary portions of the Ferrite Filter are shifted to achieve an effective single sideband selection without the necessity of changing any oscillator circuits. Figure No. 6 illustrates the various selectivity curves of the NC-270 receiver.

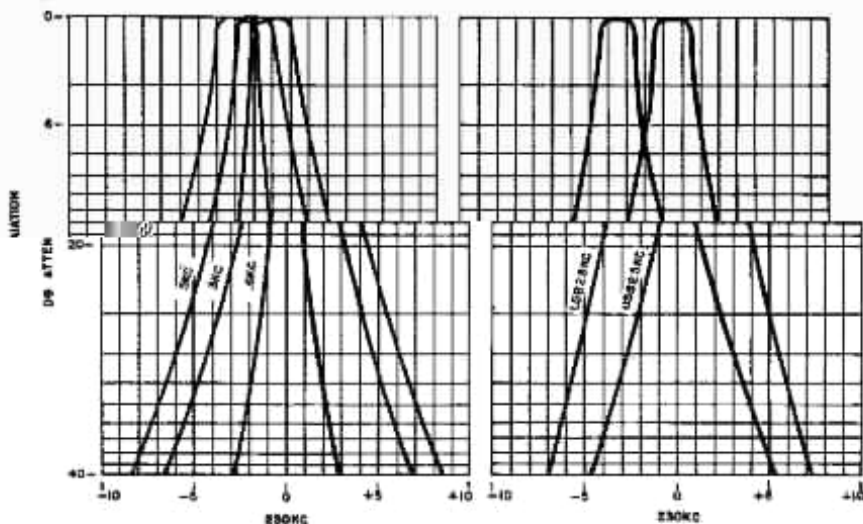

FIG. 6 SELECTIVITY CURVES

The selectivity switch of the NC-270 receiver provides for 5 degrees of AM or CW selectivity plus upper and lower sideband selection. The selectivity switch is marked with positions for 5 KC, 3 KC, L USB, 2.5 KC, U, .6 KC. The degree of selectivity selected by the operator depends largely on the mode of operation desired and the signal conditions on the amateur band. A 5 KC position would normally correspond to the highest receiver fidelity. However, under conditions of extreme signal interference, it is often times desirable to reduce the bandwidth of the receiver and sacrifice fidelity in favor of less interference through use of the 3 KC position. In the event that CW reception is desired, even further bandwidth reduction is effective and useful and it is recommended that the 600 cycle position be used. The USB and LSB positions each have a bandwidth of 2.5 KC and are centered symmetrically around the other passbands as illustrated in the selectivity curves (Figure No. 6.) This permits instant selection of upper or lower sideband without the need for retuning the main tuning dial or the beat oscillator when sidebands are changed. In normal AM operation, the 3 KC or 5 KC bandwidth positions provide an adequate degree of selectivity. For CW operation, as stated before, the 600 cycle bandwidth is recommended and for single sideband operation, the operator must choose either upper or lower sideband depending on the sideband in use.

It should be noted that for AM reception, the beat frequency oscillator should be turned off as determined by the mode switch. For single sideband or CW operation, the beat frequency oscillator should be active as determined by the mode switch and the setting of the beat oscillator controls. Both of these controls are discussed in later sections of this book. Your attention is directed to the proper description of these functions for CW and single sideband reception.

The signal appearing across the secondary winding of the Ferrite Filter is applied to the grid of the first 6BA6 1F stage which operates as a conventional signal amplifier at 230 KC. The 230 KC signal from the plate of the 6BA6 tube is coupled to the Bifilar "T" Notch circuit. The Bifilar "T" Notch circuit employs a primary and secondary tuned circuit composed of T-12 and T-13. This circuit is tuned by series capacitors and the impedance of the Bifilar choke and notch frequency circuit. The primary and secondary circuits are coupled together through the mutual inductance of the Bifilar choke with a notch frequency circuit appearing from the center tap of the Bifilar choke to ground. The circuit is so arranged that there is an effective coupling at all frequencies except at the notch frequency where the coupling impedance drops to zero, thereby effectively rejecting any signal occurring at the notch frequency. A depth control is provided in the Bifilar "T" Notch circuit to achieve a resistive balance, thereby assuring maximum selectivity of the resulting notch.



For AM reception, the control should be turned off as usual. For single sideband reception, the beat frequency oscillator controls are discussed in another section. Your attention is directed to the description of these functions in the next section.

The secondary winding of the grid of the first 6BA6 conventional signal amplifier is connected to the plate of the Bifilar "T" Notch circuit. This circuit employs a primary and secondary winding of T-12 and T-13. The primary and secondary windings are coupled together through the center tap of the Bifilar chokes with the secondary winding from the center tap. The circuit is so designed to provide maximum coupling at all frequencies where the coupling is necessary for effectively rejecting the interfering signal. A depth control is provided for the "T" Notch circuit to provide maximum rejection.

NOTCH AND DEPTH CONTROLS

The notch control tunes the rejection notch across the IF passband. When the notch is not in use, the control should always be left in the full-clockwise "OFF" position. This removes the notch from the IF passband. Effective use of the notch control depends on proper setting of the depth control. For normal operation, adjust the depth and notch controls for maximum rejection at the center of the IF passband and then use only the notch control for removing interfering signals. If the unwanted signal is very strong, set the notch control for rejection of the unwanted signal and readjust the depth control for a still greater rejection. By repeating this procedure between the two controls, a rejection of greater than 50 DB can be accomplished.

For ease in initially setting the depth control, it is recommended that the operator tune a signal and then adjust the depth control for various positions between 10 o'clock and 2 o'clock. Having chosen a setting, the notch control should be tuned across the passband to eliminate the signal. If no effect is noted, another setting of the depth control may be tried until satisfactory results are obtained. When effective rejection of the unwanted signal is observed, the operator should successively readjust both the depth and notch control to achieve the maximum rejection. Having once obtained this setting of the depth control, the depth control may be left in this position for all operating conditions and the notch control be tuned to remove unwanted signals as required, each time returning the notch control to the extreme clockwise "OFF" position when the undesirable interference condition disappears.

In AM operation, the Bifilar "T" type of rejection filter permits rejection of either the desired or the interfering signal. Rejection of either signal will remove the resulting heterodyne. The correct setting is the one that leaves the desired signal quality essentially unimpaired. If the wrong position is selected, the desired AM signal will be distorted or completely missing. In the case of single sideband reception, it is impossible to reject the desired SSB signal. However, any heterodyne between an AM signal and the BFO or between two other interfering AM signals can still be effectively removed. Under some conditions of single sideband reception, it may be desirable to adjust the notch control to place the notch in the region of the undesired sideband in order to improve the unwanted sideband rejection of the receiver. Because of the very sharp 600 cycle IF selectivity available for CW reception, it is not normally necessary to use the notch and depth controls, however, unwanted CW signals can be removed just as though they were an interfering heterodyne in the event of difficult operating conditions.

The signal appearing across the output tuned circuit of the Bifilar "T" Notch is capacity coupled to the grid of the last 6BA6 IF stage which functions as a conventional IF amplifier circuit in the AM reception mode.

The cathode of both 6BA6 IF stages and the 6BZ6 RF stage are returned to chassis by way of the RF gain bus and the RF gain control. As the resistance of the RF gain control is increased, additional cathode bias is built up across the control, thus reducing the overall receiver gain. Small resistors are used in the individual cathode leads in order to keep the RF and IF tubes in rating when the RF gain control is set at maximum.

The sensitivity of the receiver is adjusted by means of the RF gain control which controls the cathode bias on the RF and both 6BA6 IF stages. When the control is rotated to its maximum counter-clockwise position, the sensitivity of the receiver will be reduced to the point where no signal can be received. Rotating the control in the clockwise direction will increase sensitivity until maximum is reached at the full clockwise position. Under conditions of CW or single sideband reception, the RF gain control may be freely used as a means of sensitivity adjustment as the receiver is tuned from signal to signal. Under conditions of AM reception, the RF gain control should be set to a comfortable sensitivity level and allowed to remain in this position. Adjustment of the RF gain control will have some effect on the "S" meter reading. For proper indication of the "S" meter it is recommended that the receiver be detuned from any signal and the RF gain control advanced until the background noise reaches a level sufficient to cause a reading of approximately 1 "S" unit on the "S" meter. This setting of the RF gain control should then suffice for all normal AM signal conditions.

The signal appearing at the plate of the last 6BA6 IF stage is coupled to the AM detector by means of a conventional, inductively coupled, double-tuned, IF transformer operating at the second IF frequency of 230 KC. The diode at pin 6 of the 6T8 tube is used as a conventional AM detector. Resistors R25 and R26 comprise the detector load.

The AGC signal is derived from the high end of the detector load with resistors R24, R11 and capacitor C38 functioning as an AGC filter to remove the audio signal appearing across the detector load. This AGC signal is applied directly to the grid of the first 6BA6 IF tube through the secondary winding of the Ferrite Filter. The AGC signal is also applied through R44 to the grid of the 6BZ6 RF stage. A second diode of the 6T8 is applied across the AGC bus lead to the RF stage with a shunt positive voltage feed derived from the cathode of the audio output stage. This holds the AGC potential of the RF stage at zero due to the conduction of the diode until such time as sufficient AGC voltage is developed to

R.F. GAIN

overcome the positive bias applied to the clamping diode. This results in delayed AGC action on the RF stage so that the RF stage may operate at maximum gain under the weakest signal conditions, yet receive adequate AGC voltage under strong signal conditions.

The audio signal appearing across R-26, a portion of the detector load, is coupled directly to the mode switch or to the plate of the separate diode portion of the 6T8 detector-audio tube. The cathode of this diode is supplied with a filtered DC signal also derived from the detector load. The DC signal is equal in level to the peak audio amplitude, thereby keeping the diode conducting for all normal modulation. Should a noise pulse occur, the high negative noise spike across the audio portion of the detector load takes the plate of the noise limiter negative with respect to its cathode and conduction ceases, thereby effectively removing the noise peak from further signal circuits. This noise peak does not appear at the cathode of the noise limiter due to the filtering action of resistor R-27 and capacitor C-52. The audio output then occurring on the cathode of the noise limiter circuit is also coupled to the mode switch. In the event of CW or single sideband reception, the mode switch grounds the cathode of one-half of the 12AU7 tube which serves as a beat frequency oscillator using a grounded cathode Hartley oscillator circuit.

The BFO control is used to adjust the frequency of the beat frequency oscillator which correspondingly varies the pitch of the generated audio tone. When receiving single sideband signals, mid position of the beat frequency oscillator control will normally correspond to the center cross-over frequency of the two IF selectivity positions corresponding to upper or lower sideband reception. It is not normally necessary to detune the beat oscillator from this setting. When receiving CW signals, the mid-position setting of the beat oscillator would correspond to a condition wherein the maximum IF selectivity occurs at zero beat with the incoming signal and no audio tone would be observed at the point of maximum signal reception. It is therefore necessary to slightly detune the beat oscillator control in either direction to provide a suitable audio tone which is comfortable to the operator and to obtain maximum sensitivity. During CW reception, it is often convenient to adjust the beat oscillator to phase an undesired signal to zero beat, thus eliminating it as an audible interfering signal.

Signal from the beat oscillator is coupled through a small capacitor to the signal grid of the last 6BA6 IF stage which serves as a pentode product detector. The plate circuit of this last 6BA6 IF stage contains all of the various mixer products including the desired audio signal. The undesired mixer products are filtered out and the audio signal is coupled to the mode switch through an RF filter composed of resistor R-23 and capacitor C-49.

MODE

The mode switch allows selection of the AM signal or the output of the automatic noise limiter with AGC either operating or not operating, and in addition allows selection of the output from the product detector for single sideband or CW reception. In normal operation, the noise limiter may be used at will depending on incoming noise level and operating convenience. In the event that CW or single sideband reception is desired, it is essential that the mode switch be placed in the CW-SSB position.

The circuit of the mode switch is such that it selects the output of the AM detector, the automatic noise limiter or the product detector and, in addition, grounds the AGC in the CW-SSB position and in the AM and ANI positions corresponding to AGC "OFF". In addition, the mode switch is used to short out the cathode resistor of the 6BA6 last IF stage during CW and single sideband reception in order to allow efficient heterodyne mixing in the product detector.

The cathode resistor of the product detector is actually the "S" meter zero adjust control. The "S" meter is connected between the cathodes of the two 6BA6 IF stages and, as was mentioned previously, the AGC is applied to the first of these IF stages with the result that as signal amplitude increases, conduction through the first IF stage is decreased but conduction through the last IF stage remains constant thereby changing the potential difference between the cathodes which causes a current flow and an effective meter reading. The zero adjust is accomplished by adjusting the "S" meter zero adjust control to establish zero potential difference across the meter under conditions of no incoming signal.

Normal adjustment of the "S" meter is readily accomplished by increasing the RF gain control to maximum sensitivity which corresponds to its extreme clockwise setting. The receiver should be tuned so that only background noise is heard and the antenna trimmer peaked. The "S" meter zero adjust control should then be adjusted to achieve a reading of approximately S1 on the incoming noise level. This will assure proper "S" meter reading. When properly adjusted, an "S" meter reading of S0 will correspond to approximately 50 microvolts of signal at the antenna terminals.

The desired audio signal output from the mode switch is then coupled to the audio gain control and in turn, to the grid of the first audio amplifier which is the triode section of the 6T8 tube.

The audio gain control is used to adjust the speaker or earphone level to comfortable listening volume. It is important not to confuse the function of the audio gain control with the function of the RF gain control which controls the

B.F.O.

"S" METER

A.F.G.

ous selection of the AM of the automatic noise or operating or not operating selection of the output for single sideband or normal operation, the noise will depend on incoming signal convenience. In the single sideband reception is that the mode switch be position.

ch is such that it selects or, the automatic noise, detector and, in addition, SSB position and in the pending to AGC "OFF", is used to short out the last IF stage during CW in order to allow efficient ct detector.

The product detector is adjust control. The "S" the cathodes of the two mentioned previously, the these IF stages with the ic increases, conduction increased but conduction remains constant thereby ce between the cathodes and an effective meter accomplished by adjusting control to establish zero meter under conditions of

of the "S" meter is readily ing the RF gain control which corresponds to its g. The receiver should be ground noise is heard and peaked. The "S" meter ould then be adjusted to approximately S1 on the This will assure proper When properly adjusted, of S9 will correspond to vels of signal at the

ut from the mode switch n control and in turn, its lifier which is the triode

rol is used to adjust the el to comfortable listening ant not to confuse the ain control with the func- n control which controls the

overall receiver sensitivity. Normally, with the RF gain control advanced to provide proper "S" meter reading, all additional variation of listening level is accomplished with the audio gain control. In the event of operation with AGC "OFF" or in the single sideband CW mode, the RF gain control is sometimes used as the master sensitivity control and the audio gain control is left set in a predetermined position. Proper balance between the two controls under this condition is normally a matter of individual operator preference and operating habits.

The output from the plate of the first audio amplifier is impedance coupled directly to the grid of the 6CW5 audio output stage. The amplified audio is taken from the plate of the audio output stage through the audio transformer to the speaker terminals. The secondary winding of the audio transformer is designed to match a 3.2Ω speaker such as the matching NTS-3 table speaker assembly. The secondary of the audio transformer is also connected through a shorting type phone jack which is so wired that upon the insertion of a standard phone plug the loud speaker circuit will be broken and the speaker silenced.

PHONE
JACK

The head phone jack is available on the front panel and will accept any normal 2 circuit phone plug. There is no DC voltage associated with the head phone circuit. Because of the low impedance of the audio transformer secondary almost any type of head phone may be used with completely satisfactory results.

The remaining half of the 12AU7 tube is used as a 100 KC crystal controlled oscillator. The circuit is a grounded cathode, modified "Colpitts" type of circuit. The signal from the crystal calibrator is coupled to the antenna input thereby providing a strong CW signal at every 100 KC point on the dial. The circuit is turned off by the calibrator "ON-OFF" switch which functions by breaking the cathode return lead of the crystal calibrator oscillator.

CAL — SET

To properly calibrate the dial, the RF gain control should be advanced to normal receiver sensitivity and the calibrator switch should be turned to the "ON" position. The calibrator signal may then be tuned at any even 100 KC point on the dial scale corresponding to the band in use. It is sometimes convenient to use the CW mode of reception in order to add tone to the signal less difficult. After an appropriate calibrator signal has been tuned, the operator will observe that this signal may not correspond exactly to the 100 KC calibration point of the dial scale itself. In this event, the dial set control is adjusted. This control provides for lateral motion of the entire dial scale to bring the calibrated mark directly under the tuning pointer.

Once this is achieved, the calibrator may be turned off and accurate calibration will normally be encountered for the entire band in use.

The power supply of the NC-270 receiver is a conventional transformer type power supply which employs a 5Y3GT tube in a full wave rectifier circuit with a suitable power supply filter and a shunt feed to an OB2 voltage regulator tube. The OB2 is used to regulate the plate supply voltage to the high frequency or first converter oscillator and the beat frequency oscillator. A Standby-Receive switch is provided in the 145 volt supply bus in order to remove power from the plate and screens of most tubes for standby operation.

STBY — REC

The Standby-Receive switch is a two position toggle switch which may be set to standby to mute the receiver or placed in the Receive position for normal operation. An auxiliary pair of terminals on this switch is connected to the rear relay terminals in such a manner that the rear relay terminals are effectively open circuited in the Receive position and short-circuited in the Standby position. This allows control of an external relay circuit by means of the Standby-Receive switch.

The mechanical structure of the NC-270 employs a solid 3/8" panel for extreme mechanical rigidity and stability. A separate bottom cover and cabinet top are employed for ease in servicing and the National Radio Company patented Flip-Foot has been added for operator convenience.

CABINET

The Flip-Foot of the NC-270 receiver may be easily elevated into the raised position or dropped back to the flat position for maximum operating ease. To elevate the Flip-Foot, simply lift the forward portion of the cabinet and reach under and pull the rear edge of the Flip-Foot down and forward until it reaches its forward or upright position. To remove the top half of the cabinet for normal user service, it is necessary only to remove the two screws on the lower forward corner of each side of the cabinet and the two screws at the lower outside corners of the back. It is then possible to remove the cabinet top by simply lifting and springing the front top lip of the cabinet free from the retaining clips attached to the panel. The cabinet is simply replaced by reversing this procedure, taking care to engage the slots in the forward lip of the cabinet into the two clips welded to the rear of the top section of the panel. The bottom cover of the receiver may be removed independently by removing the two rear mounting feet which serve as combination mounting feet and retaining screws, and by removing the four retaining screws. Having removed these screws, the bottom cover may be slipped to the rear removing it from under the Flip-Foot and allowing free access to the wiring of the receiver.

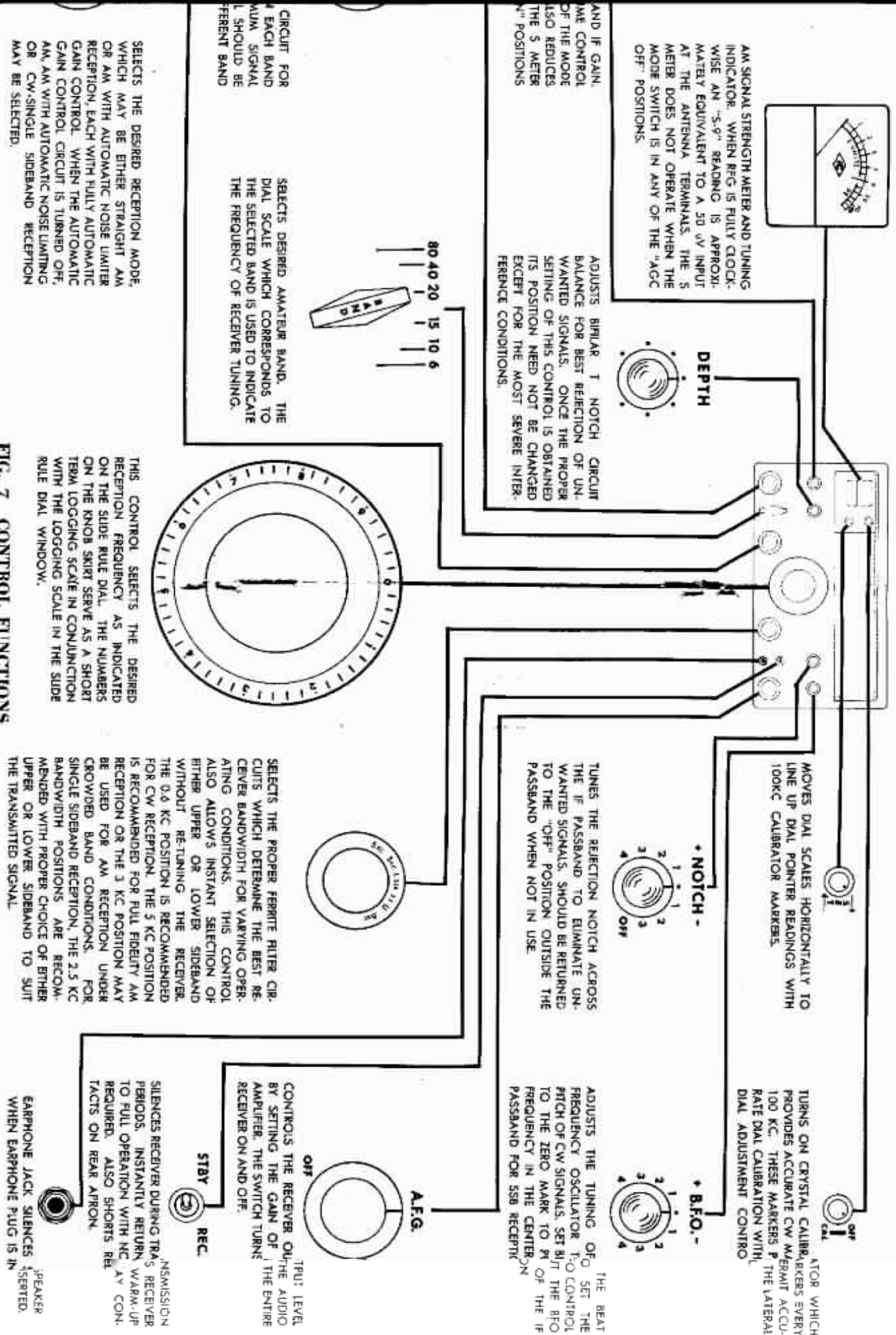

AM SIGNAL STRENGTH METER AND TUNING INDICATOR. WHEN PFG IS FULLY CLOCKWISE AN "S-9" READING IS APPROXIMATELY EQUIVALENT TO A 50 μ V INPUT AT THE ANTENNA TERMINALS. THE 5 METER DOES NOT OPERATE WHEN THE MODE SWITCH IS IN ANY OF THE "AGC OFF" POSITIONS.

ADJUSTS BIFILAR T NOTCH CIRCUIT BALANCE FOR BEST REJECTION OF UNWANTED SIGNALS. ONCE THE PROPER SETTING OF THIS CONTROL IS OBTAINED ITS POSITION NEED NOT BE CHANGED EXCEPT FOR THE MOST SEVERE INTERFERENCE CONDITIONS.

SELECTS DESIRED AMATEUR BAND. THE DIAL SCALE WHICH CORRESPONDS TO THE SELECTED BAND IS USED TO INDICATE THE FREQUENCY OF RECEIVER TUNING.

CIRCUIT FOR EACH BAND MUST BE SELECTED. SIGNAL SHOULD BE IN DIFFERENT BAND

SELECTS THE DESIRED RECEPTION MODE, WHICH MAY BE EITHER STRAIGHT AM OR AM WITH AUTOMATIC NOISE LIMITER RECEPTION, EACH WITH FULLY AUTOMATIC GAIN CONTROL. WHEN THE AUTOMATIC GAIN CONTROL CIRCUIT IS TURNED OFF, AM, AM WITH AUTOMATIC NOISE LIMITING OR CW-SINGLE SIDEBAND RECEPTION MAY BE SELECTED.

MOVES DIAL SCALES HORIZONTALLY TO LINE UP DIAL POINTER READINGS WITH 100KC CALIBRATOR MARKERS.

TUNES THE REJECTION NOTCH ACROSS THE IF PASSBAND TO ELIMINATE UNWANTED SIGNALS. SHOULD BE RETURNED TO THE "OFF" POSITION OUTSIDE THE PASSBAND WHEN NOT IN USE.

TURNS ON CRYSTAL CALIBRATOR MARKERS EVERY 100 KC. THESE MARKERS PROVIDE ACCURATE RATE DIAL CALIBRATION WITH THE LATERAL DIAL ADJUSTMENT CONTROL.

ADJUSTS THE TUNING OF THE BEAT FREQUENCY OSCILLATOR TO CONTROL PITCH OF CW SIGNALS. SET THE BFO TO THE ZERO MARK TO PITCH THE FREQUENCY IN THE CENTER OF THE PASSBAND FOR SSB RECEPTION.

CONTROLS THE RECEIVER OUTPUT LEVEL BY SETTING THE GAIN OF THE ENTIRE AMPLIFIER. THE SWITCH TURNS RECEIVER ON AND OFF.

SELECTS THE PROPER FERRITE FILTER CIRCUITS WHICH DETERMINE THE BEST RECEIVER BANDWIDTH FOR VARYING OPERATING CONDITIONS. THIS CONTROL ALSO ALLOWS INSTANT SELECTION OF EITHER UPPER OR LOWER SIDEBAND WITHOUT RETUNING THE RECEIVER. THE 0.6 KC POSITION IS RECOMMENDED FOR CW RECEPTION. THE 5 KC POSITION IS RECOMMENDED FOR FULL FIDELITY AM RECEPTION OR THE 3 KC POSITION MAY BE USED FOR AM RECEPTION UNDER CROWDED BAND CONDITIONS. FOR SINGLE SIDEBAND RECEPTION, THE 2.5 KC BANDWIDTH POSITIONS ARE RECOMMENDED WITH PROPER CHOICE OF EITHER UPPER OR LOWER SIDEBAND TO SUIT THE TRANSMITTED SIGNAL.

SILENCES RECEIVER DURING TRANSMISSION PERIODS. INSTANTLY RETURNS RECEIVER TO FULL OPERATION WITH NO LAYERS REQUIRED. ALSO SHORTS CONTACTS ON REAR APRON.

SPEAKER WHEN EARPHONE PLUG IS INSERTED.

FIG. 7 CONTROL FUNCTIONS

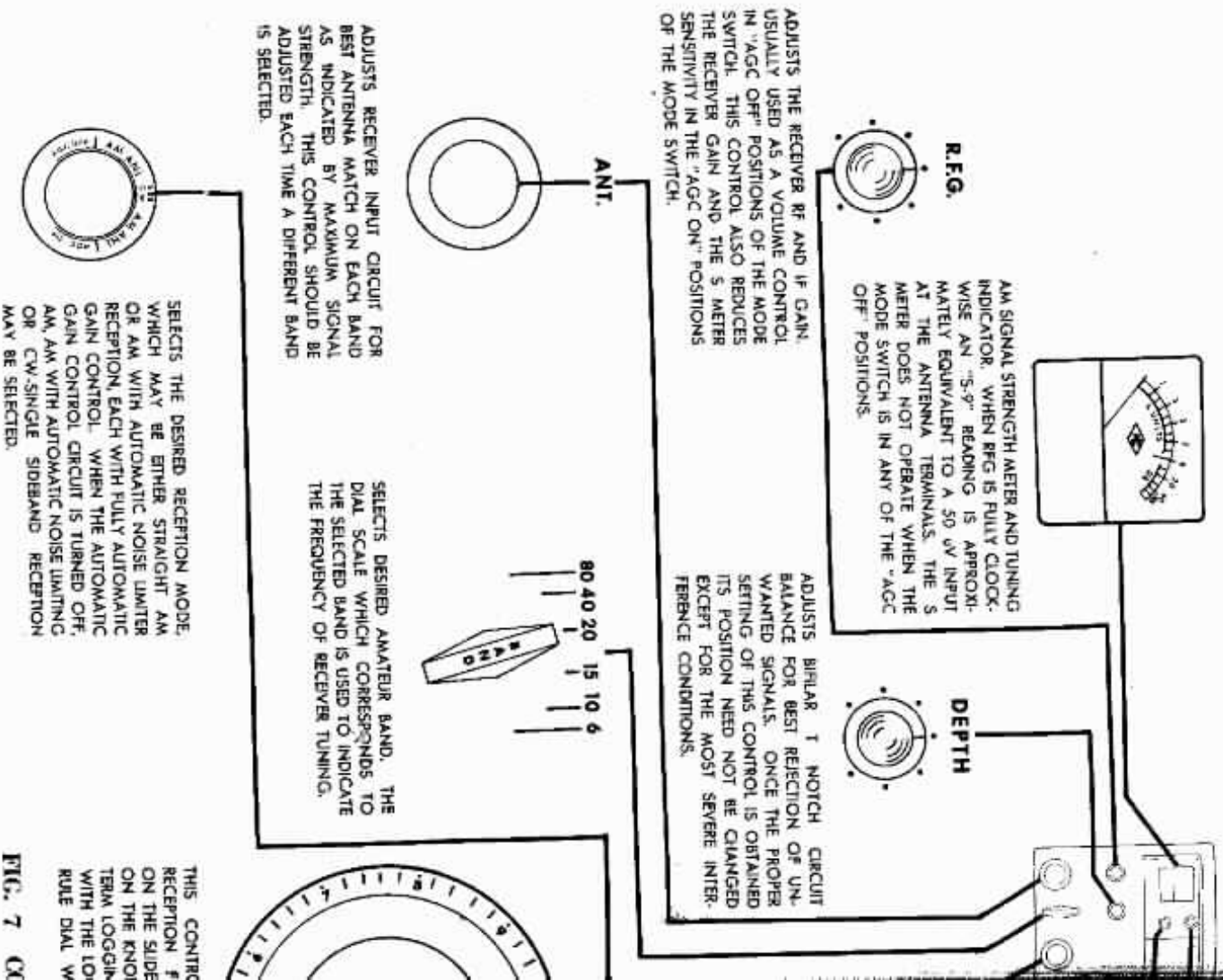

FIG. 7 CC

ALIGNMENT INSTRUCTIONS

The NC-270 receiver has been carefully aligned at the factory by specially trained and experienced personnel using precision equipment. Alignment of the receiver should not be attempted until all other possible causes of faulty operation have been investigated. Alignment should be made only by persons familiar with communications receivers and experienced in their alignment. Refer to figure 7 for location of all alignment adjustments.

EQUIPMENT REQUIRED:

1. Signal generator covering 200 KC to 55 MC.
2. Vacuum tube voltmeter (VTVM)
3. Output meter. The AC scale of the VTVM can be used.
4. Tuning Wand — General Cement No. 8278 or equivalent.
5. K Tran Tool — General Cement No. 5097 or equivalent.

INITIAL CONTROL SETTINGS:

Bandswitch	As indicated in chart.
RF and AF Gain	Fully Clockwise
Mode Switch	AM with AGC off.
Selectivity	As indicated in chart.
Tuning	Plates half-meshed unless otherwise indicated.
Antenna Trimmer	Mid range.
Lateral Dial Adjustment	Mid range.
Notch Frequency	Fully Clockwise, (lowest frequency).
Notch Depth	Mid range.
Calibrator	Off.

ALIGNMENT PROCEDURE:

230 KC IF ALIGNMENT

Signal Generator Connections	Signal Generator Frequency	Bandswitch Setting	Output Connections	Selectivity Setting	Remarks
High side directly to pin 7 of 2nd 6BE6. Low side to chassis.	230 Kc (unmodulated)	80 M	VTVM DC Probe to junction of R24, R25 and C51. Low side to chassis.	0.6 Kc	Adjust F1.1, F1.2 for maximum indication. Rock generator to insure both cores tune through maximum. Peak T12, T13 and both sides of T14. Maintain approximately 2V reading on VTVM.

2215 KC IF ALIGNMENT

Signal Generator Connections	Signal Generator Frequency	Bandswitch Setting	Output Connections	Selectivity Setting	Remarks
High side directly to mixer section of tuning gang.	2215 Kc (unmodulated)	80 M	VTVM DC Probe to junction of R24, R25 and C51. Low side to chassis	0.6 Kc	Tune generator slowly to determine center of 230 Kc IF passband. Set generator at point of maximum response. Peak top and bottom of T11. Maintain approximately 2V reading on VTVM.

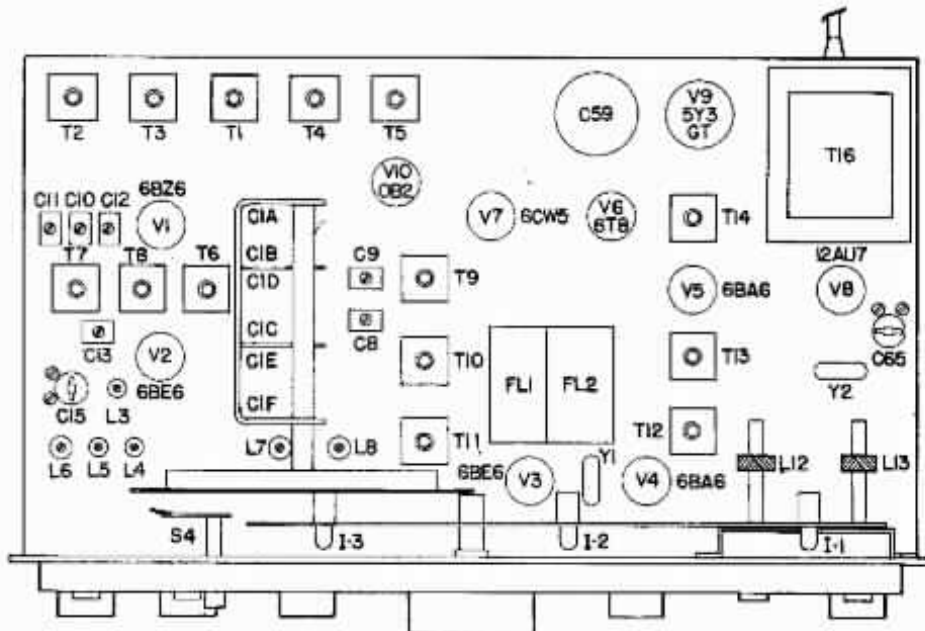

TOP VIEW

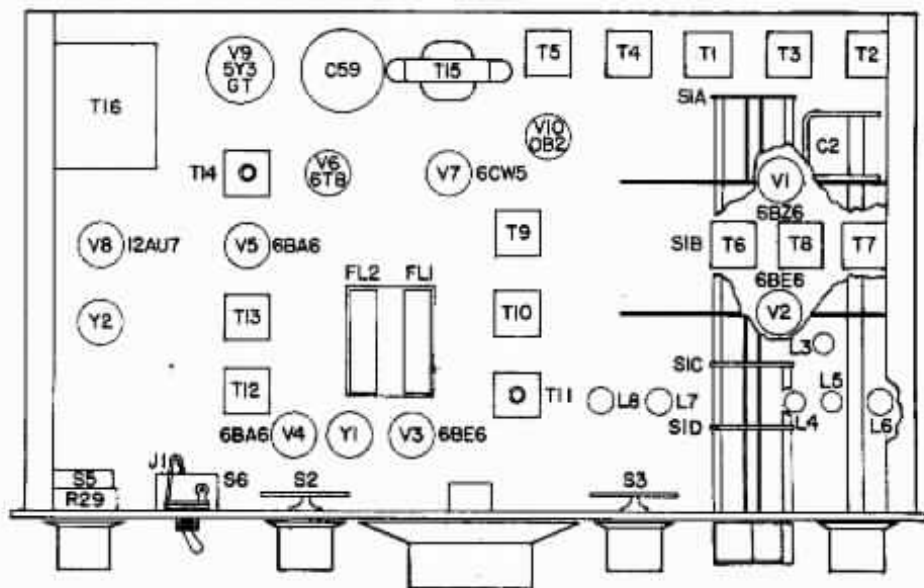

BOTTOM VIEW

FIG. 8 ALIGNMENT LOCATIONS

RF ALIGNMENT

Before proceeding with RF Alignment, check dial pointer for proper indexing. With tuning gang fully closed, position the pointer on the dial cord so that the pointer reads exactly 2 on the logging scale with lateral dial set adjusted to mid position.

Output Meter Connections — VTVM DC probe to junction of R24, R25 and C51. Low side to chassis.

Maintain approximately 2V reading on VTVM.

Signal Generator Connections — Connect high side of generator to "Ant." terminal through a 68 Ω $\frac{1}{2}$ W resistor. Low side to chassis.

Control Settings — Adjust generator for 30% modulation. Set selectivity control for 3.0 Kc and all other controls at the initial settings given previously.

General Instructions — Always check for proper tracking on each band by inserting tuning wand into mixer and antenna transformers. Repeat high and low end steps until tuning wand shows reduced output with either end inserted into both the mixer and the antenna coils. If pointer does not read close to the correct frequency at the low end of all bands (except 6M), C15 must be re-adjusted. If pointer reads above the correct frequency, reduce C15 capacity. If pointer is below, reduce C15 capacity. Then repeat the entire RF Alignment procedure, omitting all C15 adjustments.

	Bandswitch Setting	Generator & Receiver Frequency	Adjust for Maximum
Step No. 1	6 M	50.0 Mc	L3 (osc. slug) L10 (mixer coil) spread turns L9 (Ant. coil) spread turns with antenna trimmer $\frac{1}{4}$ closed
Step No. 2	6 M	54.0 Mc	C15 (osc. trimmer) C13 (mixer trimmer) C2 (ant. trimmer)
Step No. 3	10 M	29.7 Mc	L4 (osc. slug) C12 (mixer trimmer) C2 (Ant. trimmer)
Step No. 4	10 M	28.0 Mc	T6 (mixer slug) T1 (ant. slug)
Step No. 5	15 M	21.5 Mc	L5 (osc. slug) C11 (mixer trimmer) C2 (ant. trimmer)
Step No. 6	15 M	21.0 Mc	T7 (mixer slug) T2 (ant. slug)
Step No. 7	20 M	14.4 Mc	L6 (osc. slug) C10 (mixer trimmer) C2 (ant. trimmer)
Step No. 8	20 M	14.0 Mc	T8 (mixer slug) T3 (ant. slug)
Step No. 9	40 M	7.3 Mc	L7 (osc. slug) C9 (mixer trimmer) C2 (ant. trimmer)
Step No. 10	40 M	7.0 Mc	T9 (mixer slug) T4 (ant. slug)
Step No. 11	80 M	4.0 Mc	L8 (osc. slug) C8 (mixer trimmer) C2 (antenna trimmer)
Step No. 12	80 M	3.5 Mc	T10 (mixer slug) T5 (ant. slug)

BFO ALIGNMENT

Signal Generator Connections	Signal Generator Frequency	Bandswitch Setting	Output Connections	Selectivity Setting	Remarks
High side directly to pin 7 of 2nd 6BF6. Low side to chassis	230 Kc (unmodulated)	80 M	VTVM DC probe to junction of R24, R25, and C51. Low side to chassis.	0.6 Kc	Rock generator for maximum output. Maintain approx. 2V reading on VTVM. Set mode switch to CW-SSB. Set BFO knob to center mark on panel. Loosen set screw and adjust L13 to zero beat with screwdriver through hole in shield. Then tighten set screw and return mode switch to AM-AGC Off position.

NOTCH FREQUENCY ALIGNMENT

Signal Generator Connections	Signal Generator Frequency	Bandswitch Setting	Output Connections	Selectivity Setting	Remarks
High side directly to pin 7 of 2nd 6BF6. Low side to chassis.	230 Kc (unmodulated)	80 M	VTVM DC probe to junction of R24, R25, and C51. Low side to chassis.	0.6 Kc	Rock generator for maximum output. Set "Notch Frequency" knob to center mark in panel and loosen set screw. Adjust L12 and depth control for lowest possible output indication. Increase generator level as necessary. Tighten set screw.

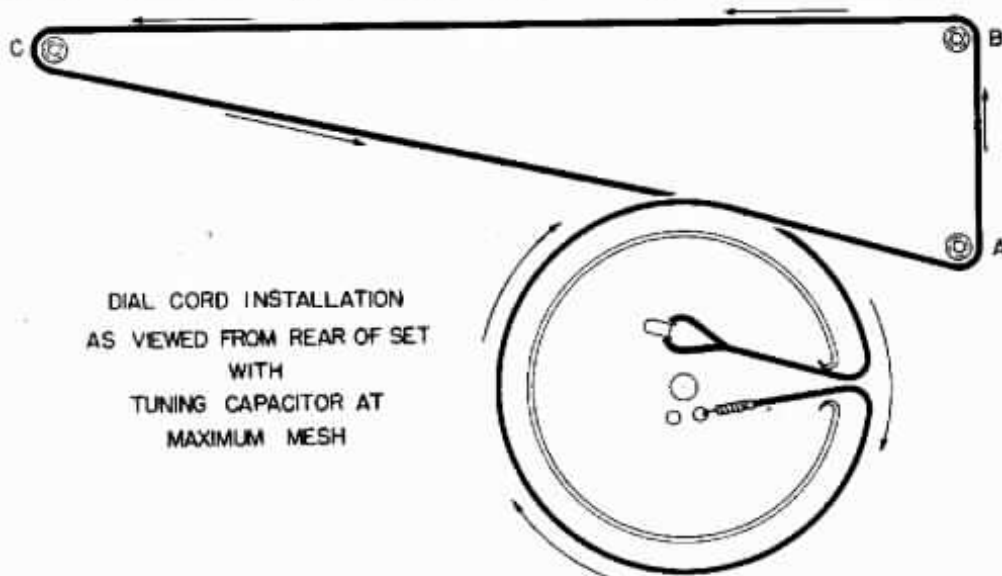

FIG. 9 DIAL CORD ASSEMBLY

GENERAL SERVICE INFORMATION

DIAL CABLE RESTRINGING

1. Remove the chassis from the cabinet.
2. Turn the tuning dial so that the tuning gang capacitor is fully meshed.
3. Hook the loop in the new dial cord through the tab on the dial cord drum.
4. Pull the dial cord through the slot in the tuning drum and proceed around the drum $\frac{3}{4}$ of a turn in a clockwise direction as viewed from the rear of the set. In this step a piece of masking tape may be used to hold the dial cord in place while obtaining the $\frac{3}{4}$ turn.
5. Bring the cord under and around pulley A, up over pulley B then across the top of the set and around pulley C. Bring the cord back to the top of the tuning drum and proceed around the drum in a clockwise direction as viewed from the rear of the set for $\frac{1}{4}$ turns.
6. Finish up by routing the cord back through the slot on the tuning drum and connecting it to the cord spring. This spring should be stretched approximately $\frac{1}{16}$ " beyond its relaxed length when it is hooked into the middle hole on the tuning drum.
7. Set the pointer on the pointer rail and engage the dial cord through the three tabs on the back of pointer guide. Do not crimp these tabs at this time.
8. Move the pointer along the dial cord until it reads (2) on the logging scale with the dial adjust mechanism holding the scale at the mid point of its travel and the tuning capacitor gang fully closed. Then crimp the tabs to hold pointer in this position.

BFO FREQUENCY CHECK

The beat frequency oscillator (BFO) has been carefully adjusted at the factory so that its frequency is 230.0 Kc. Re-adjustment of the BFO will normally not be required unless the 12AU7 BFO tube or components in the BFO circuit have been replaced. A slight re-adjustment sometimes may be necessary as a result of normal aging of the BFO tube. A simple check can be made to determine if the adjustment is necessary as follows:

With the mode switch in the CW-SSB position and the selectivity switch at 5 Kc, tune the receiver to a spot on one of the bands where no signals are being received. Set the receiver gain controls such that the background noise can be heard. Set the BFO control to the center of its range at the panel mark, turn the selectivity switch to the 2.5 Kc U position and carefully observe the pitch of the background noise. Then turn the selectivity switch to the 2.5 Kc L position and notice if the predominant pitch of the background noise has changed. If the predominant pitch of the background noise in this position does not sound the same as that obtained in the 2.5 Kc U position, adjust the BFO control until the pitch in the U and L positions sound the same. Note the position of the BFO control. It should be at or very near the center of its range as indicated by the red line

at the center panel marking. If the BFO control is more than $\frac{1}{4}$ division away from the center of its range, the BFO requires re-adjustment. See the section on Alignment pertaining to BFO adjustment.

NOTCH FREQUENCY CHECK

Re-adjustment of the notch filter circuit is not normally necessary unless the components in the notch filter circuit are replaced. To check the circuit, proceed as follows: Check the BFO frequency as described above. Set the BFO to the center of its range. Set the mode switch to SSB-CW and the selectivity control to 3 Kc. Tune in an unmodulated carrier from the crystal calibrator, a signal generator or a transmitter for zero beat. Turn the mode switch to AM AGC "on". Adjust the strength of the incoming signal for approximately an S9 meter reading. Turn the notch frequency control for minimum reading on the "S" meter. The depth control may also have to be adjusted to obtain this minimum. When this minimum is obtained, the notch frequency dial should be set to its mid panel mark. If the notch frequency check indicates that an adjustment is necessary, proceed as shown in the Alignment section.

CRYSTAL CALIBRATOR CHECK

The crystal adjustment trimmer near the 100 Kc crystal is connected across the 100 Kc calibrating crystal. This trimmer capacitor permits slight adjustment of the calibrating crystal to exactly 100 Kc by comparison with a signal transmitted by station WWV or another station whose frequency is known exactly and is also an exact multiple of 100 Kc. This is done by tuning an auxiliary receiver to such a station and then setting the crystal adjustment control until the 100 Kc calibrator signal is zero beat with the signal being picked up by the auxiliary receiver. Coupling between the 100 Kc calibrating signal and the auxiliary receiver may be obtained by placing a clip lead on the antenna terminal of the auxiliary receiver and placing it near the 100 Kc crystal or the 12AU7 calibrator tube. The crystal adjusting capacitor has been set at the factory and should not require periodic re-adjustment unless extreme calibration accuracy is desired.

GENERAL SERVICE AND OPERATING INFORMATION

For any further information regarding operation or servicing of your NC-270 receiver, contact your National Radio Company dealer. The National Radio Company maintains an extensive system of authorized service agencies where any required service will be performed promptly and efficiently at a nominal charge. For location of the authorized service agency nearest you, consult your local dealer or your telephone directory. The National Radio Company reserves the right to make revisions in the current production of equipment and assumes no obligation to incorporate these revisions in earlier models.

PARTS LIST

ALL READILY AVAILABLE RESISTORS AND CAPACITORS ARE OMITTED FROM THE FOLLOWING PARTS LIST, BUT ARE COMPLETELY IDENTIFIED ON THE SCHEMATIC.

PART NAME	PART NUMBER	PART NAME	PART NUMBER
Jack Phono	A11998	Resistor 330 Ω 10W \pm 10%	B17436-1
Plug Phono	A11153	Capacitor—Mica 180uuf \pm 2%	NCS-20-181-G-5
Panel Terminal (Relay)	A12616	Capacitor—Mica 3900uuf \pm 1%	NCS-20-392-F-5
Panel Terminal (Speaker)	A12617	Capacitor—Mica 130 uuf \pm 2%	NCS-15-131-G-5
Panel Terminal (Antenna)	E265-28	Capacitor—Mica 18 uuf \pm 5%	NCS-15-180-J-5
Socket 7 pin Black Phenolic	B27669-3	Capacitor—Ceramic 100 uuf \pm 2%	
Socket 9 pin Black Phenolic	B27668-1	Special \pm 10 PPM	A50113
Socket Octal	B27674-1	RF Choke Encapsulated	A50206-1
Transformer — Output	B22025-2	Bifilar T Coil	B50191
Main Tuning Capacitor	C50177-2	Choke 5 uh	B50198
Disc Drive	A50125	Line Cord	B22132-5
Trimmer Ceramicon	B19783-2	Front Panel — Complete	D50116-3
Transformer — Power	C50087	Coil Mtg — Bushings	A50107
Capacitor — Electrolytic	C19458-5	Clamps	A50148-52
Capacitor — Mica Trimmer	A50137	Slug Iron	B50188-4
Potentiometer — S Meter	B50088	Coil BFO	B50201
Potentiometer — AF Gain	B50089	Coil BiFilar Tuning	B50202
Switch — Selectivity	B50090	Spring Slug Screw	B50112
Switch — Mode	B50091	Coil Shield Assy with Fasteners	B56276-3
Potentiometer — RF Gain	B50092	Window — Complete	C50123-3
Potentiometer — Depth Control	B50189	Dial — Complete	C50124-3
Phone Jack	A50263	Spring Friction	A50147
Switch Toggle	B50205	Pointer Rail	B50110
RF Shield	C50093	Bracket Switch Mtg.	A50121
Switch Band	C50094	Bracket Light Mtg.	C50298
Variable Capacitor — Antenna	B50095	Bracket Window Mtg.	B50120
Panel Bushing	A50118-2	Window Light Shield	B50122
Coupling Spring	B25000	Switch Calibrate	B50108
Transformer — IF Output	B50103	Fiduciary Assy	B50131
Transformer — T Notch	B50104	"S" Meter	C50219
Transformer — 2215 KC	B50209	Pointer	B50130
Coil — Antenna 80 M	B50167	Dial Cord Assy	B19347-7
Coil — Antenna 40 M	B50161	Bushing Panel	A50118-1
Coil — Antenna 20 M	B50168	Bushing Nut	A50117-1
Coil — Antenna 15 M	B50169	Pinch Assy	B50135
Coil — Antenna 10 M	B50170	Bowed Ring (Snap)	A50282-5
Transformer RF 80 M	B50171	Bezel Front Panel	B50132
Transformer RF 40 M	B50172	Knob — BFO or Notch	B50111-2
Transformer RF 20 M	B50173	Knob — RFG or Depth	B50109-2
Transformer RF 15 M	B50174	Set Screw No. 6 X 5/16	SS-6-B-N-5-Z
Transformer RF 10 M	B50175	Set Screw No. 6 X 1/4	SS-6-B-N-2-Z
Mounting Clip	A19405	Knobs — AFG & Ant.	D22500-X 38-X-4T
Coil Osc. 80 M	B50197	Knob — Mode	D22500-X38-X-4U
Coil Osc. 40 M	B50196	Knob — Selectivity	D22500-X38-X-4V
Coil Osc. 20 M	B50195	Knob — Band	C11916-4
Coil Osc. 15 M	B50194	Knob Assy, Main Tuning	B13599-3
Coil Osc. 10 M	B50193	Knob Painted, Calibrate & Lateral	
Coil Osc. 6 M	B50192	Dial Adj.	A50142-2
Coil Antenna 6 M	B50190	Crystal 100KC	B50114
Coil RF 6 M	B50200	Crystal 2445 KC	B50115

PART NAME	PART NUMBER	PART NAME	PART NUMBER
—Panel Lamp	NPL-51	Sockets, Light	B50300
6BZ6 Tube	6BZ6	Flip Foot	B50145-2
6BE6 Tube	6BE6	Rivets	SR-125-B-14-N
6BA6 Tube	6BA6	Push on Timmerman	A50284-1
6T8 Tube	6T8	Glide	A50280
12AU7 Tube	12AU7	Rubber Foot	A50281-2
6CW5 Tube	6CW5	Bottom Cover Painted	C50179-2
OB2 Tube	OB2	Cabinet Assy Complete	D50139-5
5Y3-GT Tube	5Y3-GT		

STANDARD FORM WARRANTY
of
NATIONAL RADIO COMPANY, INC.

A Wholly owned subsidiary of NATIONAL COMPANY, INC.

This equipment is warranted to be free from defective material and workmanship and repair or replacement will be made of any part which, under normal installation, use and service discloses defect, provided the unit is delivered by the owner to the manufacturer or through the authorized radio dealer or wholesaler from whom purchased, intact, for examination, with all transportation charges prepaid to the factory, within ninety days from the date of sale to original purchaser, and provided that such examination discloses in the manufacturer's judgment that it is thus defective.

Damages arising out of the breach of warranty to the owner shall be limited to the return of the goods and repayment of the purchase price or to the repair or replacement of non-conforming goods or parts at the election of the manufacturer.

This warranty does not extend to any radio products which have been subjected to misuse, neglect, accident, incorrect wiring, improper installation, or to use in violation of instructions furnished by the manufacturer, nor does it extend to units which have been repaired or altered outside of the factory, nor to cases where the serial number thereof has been removed, defaced or changed, nor to accessories used therewith of other manufacture.

Any part of a unit approved for remedy or exchange hereunder will be remedied or exchanged by the authorized radio dealer or wholesaler without charge to the owner.

This warranty is in lieu of all other warranties expressed or implied and no representative or person is authorized to assume for the manufacturer any other liability in connection with the sale of their radio products.

National Radio Company, Inc. reserves the right to make any change in design or to make addition to, or improvements in, its products without imposing any obligations upon itself to install them in its products previously manufactured.

NATIONAL RADIO COMPANY, INC.
Melrose 76, Mass.

SPECIFICATIONS

Frequency Ranges

6 meter band (50.0 - 54.0 Mc)
 10 meter band (28.0 - 29.7 Mc)
 15 meter band (21.0 - 21.5 Mc)
 20 meter band (14.0 - 14.4 Mc)
 40 meter band (7.0 - 7.3 Mc)
 80 meter band (3.5 - 4.0 Mc)

Tuning Control

12:1 step down ratio with pinch type drive for smooth inertia tuning.

Calibration

Built-in 100 Kc crystal calibrator and exclusive National lateral dial adjustment provide extreme calibration accuracy.

Intermediate Frequencies

1st IF — 2,215 Kc 2nd IF — 230 Kc

Image Rejection

Double conversion superheterodyne circuit provides optimum image and intermediate frequency rejection on all bands.

Sensitivity

Better than 1.5 microvolt for 1 watt output, 10 db signal to noise ratio.

Selectivity

Special patented "Ferrite Filter" provides instant SSB selection and the following bandwidths:

VERY SHARP — 600 cycles
 USB — 2.5 Kc
 LSB — 2.5 Kc
 MEDIUM — 3.0 Kc
 BROAD — 5.0 Kc

Reception of CW Signals

Product detector circuit with separate beat frequency oscillator.

Interference Rejection

Bifilar "T" Notch rejection circuit, tunable over entire IF bandwidth, provides greater than 50 DB of interfering signal rejection.

Noise Limiter

Automatic type, self-adjusting to various signal levels.

Signal Strength Meter

Calibrated in S units from "S-1" to "S-9" at 50 uV input and "10 DB" to "60 DB" above S-9.

Audio Power Output

3.0 watts, better than 1.5 watts at 10% distortion.

Antenna Input

72 Ω , unbalanced on all bands.

Output Circuit

32 Ω for loudspeaker. Separate front panel headphone jack.

Reception of Amplitude Modulation Signals

A separate linear diode detector is used. Front panel selection of Automatic or Manual Gain Control.

Reception of Single Sideband Signals

Special patented "Ferrite Filter" provides instant selection of upper and lower sideband with special product detector and separate carrier re-insertion.

Control Circuit

Standby-Receive switch with separate set of contacts for external operation available at rear of receiver. Rear panel circuit is closed in the Standby position only.

Power Line Requirements

105-125 volts A.C. 50-60 cycles 75 watts

Front Panel Controls

Tuning		Selectivity switch
Radio frequency gain		5.0 KC
Notch depth		3.0 KC
Notch frequency		USB } 2.5 KC
Beat frequency oscillator		LSB }
Antenna trimmer		0.6 KC
Bandswitch		
Mode switch	AM } AGC on	Phone jack
	ANL }	Standby-Receive Switch
		Audio gain control
	CW-SSB } AGC off	Calibrator switch
	AM }	Calibration set
	ANL }	

Flip Foot

Unique "Flip Foot" on receiver and matching speaker for maximum operating convenience.

Dimensions

8 $\frac{3}{4}$ " high 15 $\frac{3}{4}$ " wide 9" deep
 Shipping Weight 28 lbs.

Specifications subject to change without notice.

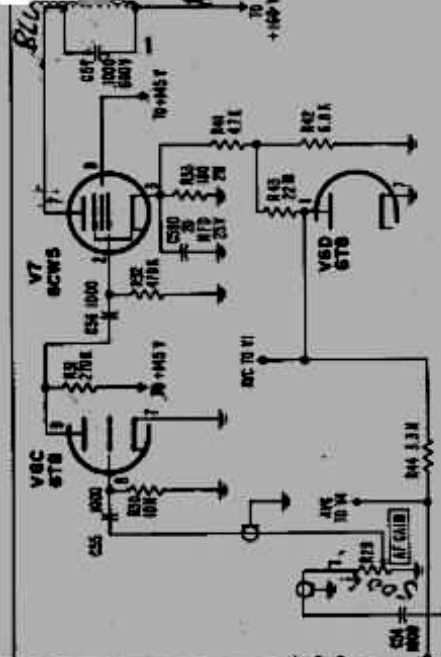
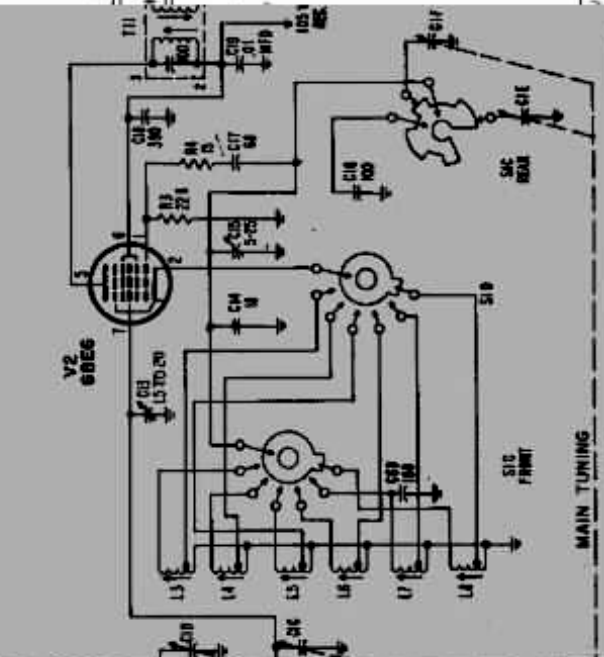
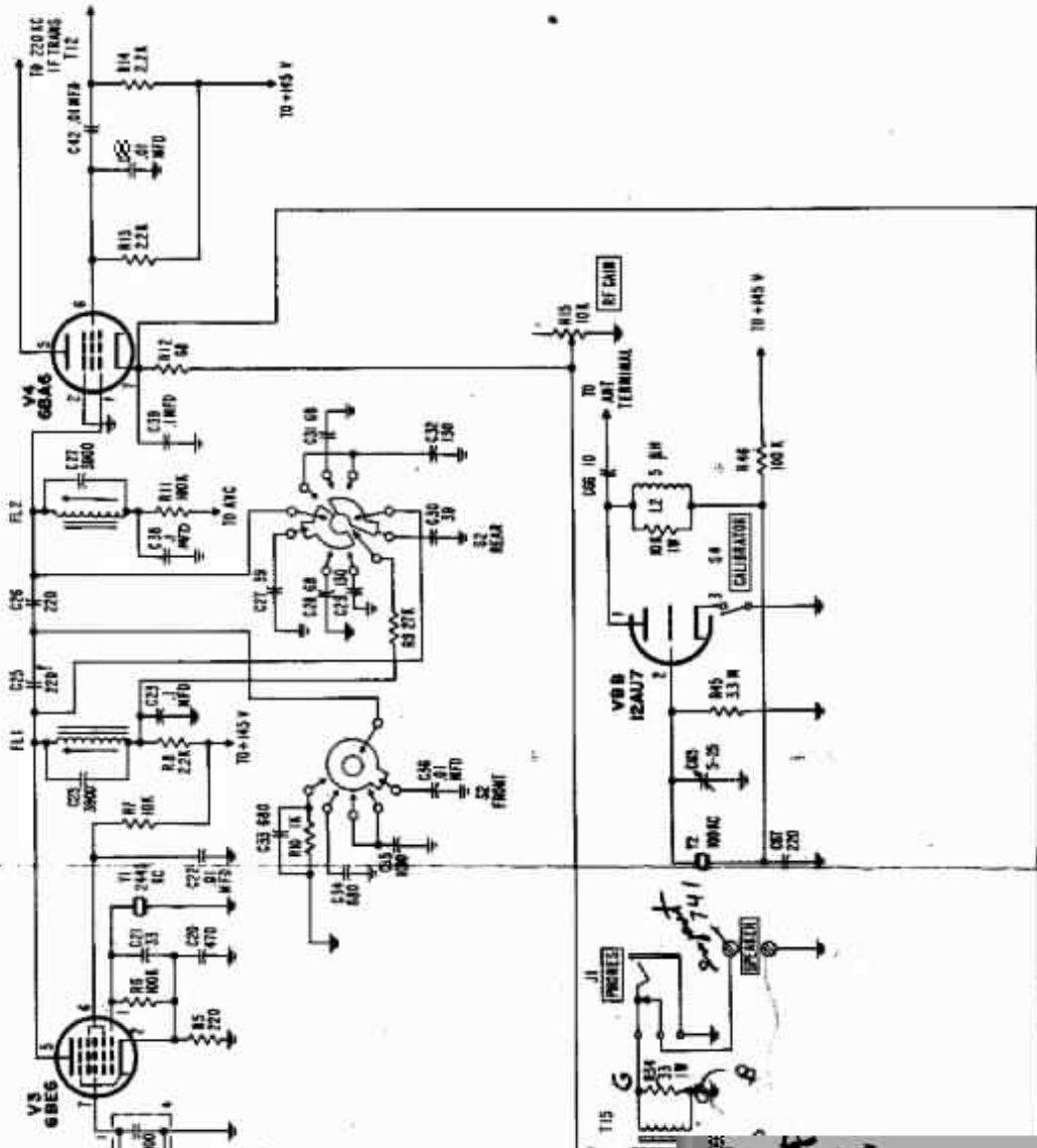

70 SCHEMATIC

FIG. 10 NC-2