

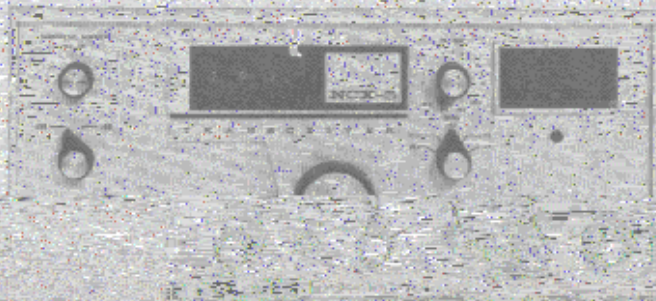

**NATIONAL RADIO COMPANY**  
37 WASHINGTON STREET • MELROSE, MASSACHUSETTS

**VER**

**NCX-5 TRANSCEI**



# INDEX

	Page
<b>SECTION 1 GENERAL DESCRIPTION</b> .....	<b>2</b>
<b>SECTION 2 INSTALLATION</b> .....	<b>3</b>
2.1 Power Supplies	
2.2 Mobile Mounting	
2.3 Microphone Connections	
2.4 Mobile Speaker Installation	
2.5 Auxiliary Relay Control Terminals	
<b>SECTION 3 OPERATION</b> .....	<b>5</b>
3.1 Tuning Procedures	
3.2 Detailed Use of the Individual Controls	
<b>SECTION 4 THEORY OF OPERATION</b> .....	<b>11</b>
4.1 General	
4.2 The Transmitter	
4.3 The Receiver	
4.4 The VOX Circuits	
4.5 The Function Switches	
4.6 Relay Functions	
<b>SECTION 5 ALIGNMENT</b> .....	<b>15</b>
5.1 Equipment Required	
5.2 Initial Control Settings	
5.3 IF Alignment Procedure	
5.4 Balanced Modulator Adjustment	
5.5 Carrier Oscillator Setting	
5.6 Transmitter Bandpass Tuning	
5.7 Receiver Bandpass Tuning	
5.8 VFO Frequency Alignment	
5.9 VFO Linearity Adjustment	
5.10 VFO Sideband Switching Adjustment	
5.11 Temperature Compensating Adjustment	
5.12 Transmit Mixer and Driver Alignment	
5.13 Final Amplifier Preliminary Adjustment (10 Meter)	
5.14 Neutralizing Capacitor	
5.15 Final Amplifier Preliminary Adjustment (80—15 Meter)	
5.16 Final Amplifier Tuning Checks	
5.17 Local Oscillator Crystal Adjustment	
5.18 Parasitic Check	
5.19 Carrier Suppression, Sideband Suppression, Modulation, and ALC Checks	
5.20 Antenna and Receiver Frequency Check	
5.21 USB—LSB Switching Check	
5.22 Switching Tests	
5.23 Transceiver Verniers	
5.24 Anti-VOX Check	
5.25 VFO Jack	
<b>SECTION 6 PARTS LIST</b> .....	<b>24</b>
<b>SECTION 7 VOLTAGE AND RESISTANCE MEASUREMENTS</b> .....	<b>26</b>

# SECTION 1

## GENERAL DESCRIPTION

The NCX-5 is a five band high-performance transceiver for the 80, 40, 20, 15, and 10 meter amateur bands, intended for use in fixed home installations, as well as for portable and mobile application. The NCX-5 provides choice of SSB, CW, or AM operation with unusually accurate dial calibration and high frequency stability, together with operating features in all three modes normally available only with separate receiver-transmitter combinations.

A NATIONAL 8-pole crystal lattice filter with a 6 to 60 db. shape factor of 1.7:1 and a bandwidth of 2.8 Kc @ 6 db. provides sideband suppression and receiver selectivity previously found only in commercial communications equipment.

band to reduce QRM or to make accurate SSB suppression checks with the calibrated S-meter.

ALC (automatic level control) is incorporated in the NCX-5. Effective talk power is increased and microphone gain and speech loudness are made non-critical by this system. The 10 db. range of the ALC circuit in the NCX-5 prevents "flat topping" and splatter.

An ALC INPUT JACK is provided on the NCX-5 for use with the NCL-2000 2 Kw linear amplifier for control of the NCX-5 by the ALC voltage from the NCL-2000.

Choice of VOX-PTT-MANUAL operation is

performed from the front panel. When operating in SSB mode, the front panel provides easy adjustment and resetability.

The SOLID STATE VFO eliminates the drastic initial warm-up drift so characteristic of tube type VFO's. The stability of this VFO, together with the controlled pitch of the receiver and transmitter combination.

BREAK-IN GRID BLOCK KEYING for CW operation accomplishes automatic transmit-receive switching at the tap of a key.

Two detectors are incorporated in the product detector for SSB, CW, or exalted AM and an excellent diode detector for AM.

A TRANSCIVE VERNIER control in the NCX-5 allows independent adjustment of the receiver frequency from that of the transmitter section over a range of 2 Kc from the displayed (transmitter) frequency.

A VFO INPUT JACK connects to the optional VFO console. The VX-501 when connected to the NCX-5, provides completely independent of transmit and receive frequencies, as well as receive control by either the VX-501 or the NCX-5. Besides its VFO function, the VX-501 provides crystal control of the NCX-5 transmit and receive frequencies.

SIDEBAND SELECTION is possible at the flick of a switch (USB-LSB) without retuning the VFO. The operator may instantly select the opposite side-

## SECTION 2 INSTALLATION

### 2.1 POWER SUPPLIES:

The NCX-5 transceiver may be used with either the matching NCX-A 115/230 volt A.C. or the National 12 volt D.C. power supplies. We strongly recommend use of the National Power Supplies designed for the NCX-5 because of their extremely "stiff" voltage regulation and superior filtering.

NCX-A power supplies with serial numbers beginning with 73 or higher are designed for operation with the NCX-5 transceiver. NCX-A power supplies with serial numbers beginning with 44, 49, 57, 63, 39, or 72 must be modified before use with the NCX-5 transceiver. This modification may be easily made by connecting a 560 ohm 10 watt resistor in parallel with the two 330 ohm 10 watt resistors R-5 and R-6 in the NCX-A power supply. A partial user manual for the revised supply is shown in Figure 7.

### 2.2 MOBILE MOUNTING:

The NCX-5 transceiver is designed for operation with the NCX-A power supply. For mobile operation, this bracket should be mounted in the automobile dash or on a panel. With two #10-32 x 1/4" screws, for maximum stability, these screws should be located as far apart as possible in the mobile mounting bracket. A pair of large threaded knobs hold the transceiver directly to the brackets. These knobs permit rapid installation or removal of the transceiver from the mount. Mobile operation usually results in considerable vibration and shock. For maximum frequency stability of the NCX-5 transceiver, it is important that all mounting screws used to hold the cabinet to the chassis and panel assembly be in place and firmly tightened. If mobile use, the rubber feet may be removed from the bottom of the NCX-5.

### 2.3 MICROPHONE CONNECTIONS:

The microphone input of the NCX-5 is equipped with a three circuit jack providing a ground on the main shank of the three circuit plug. The audio output of a high impedance ceramic or dynamic microphone (a crystal microphone may be used, but is not recommended for mobile operation) should be connected to the ring of the three circuit jack. If the microphone is equipped with a push-to-talk button, the push-to-talk button should be so wired that the

tip of the microphone plug is connected to the grounded shank of the plug when the push-to-talk button is pressed. The microphone push-to-talk button is connected to the -40 volt bias.

### — CAUTION —

Accidental interchange of the wiring on the microphone plug will result in application of -40 volts to the microphone cartridge, which may damage the microphone.

The microphone input jack of the NCX-5 is equipped with a grounding contact so that no voltage is applied to the microphone when the microphone plug is removed. Microphone connections are illustrated in Figure 8. We recommend the use of a good quality, wide range microphone. If a full frequency restriction of 200 Hz to 20 kHz is accomplished, the NCX-5 crystal lattice filter has the effect of the microphone should be modified to permit operation without depressing the P.T.T. button. This may be done by bending one of the shorting contacts on the microphone so that it does not short microphone cartridge terminals when the button is released.

### 2.4 MOBILE SPEAKER INSTALLATION:

When the NCX-5 is installed in an automobile for use with the D.C. supply unit, it is usually convenient to use the speaker of the regular mobile broadcast radio. Two leads should be brought out of the 12 terminal Jones plug at the rear of the NCX-5 on pins 5 and 7 and connected to the speaker through a DPDT switch mounted under the dash to allow choice of speaker operation with either the NCX-5 or the standard broadcast radio.

### 2.5 AUXILIARY RELAY CONTROL TERMINALS:

A pair of SPST relay terminals rated at 3 amp current capacity is provided at the rear of the NCX-5 to allow control of accessory equipment such as a NCL-2000 amplifier. Terminals are open during receive, closed during transmit.

INSTALLATION

FIGURE 1

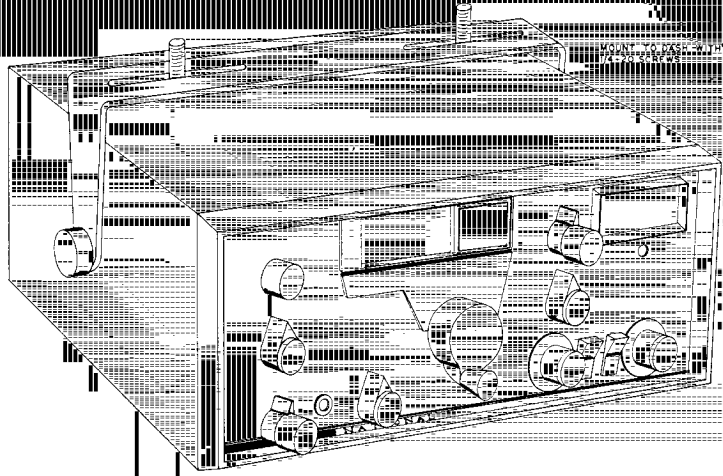

- 1 POWER SWITCH
- 2 POWER SWITCH
- 3 -80VOLT BIAS@6MA
- 4 12.6VOLT HEATER@60MA

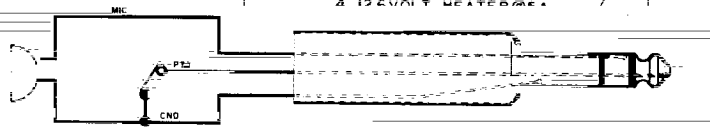

MICROPHONE CONNECTIONS

- 5 SPEAKER GROUND
- 6 COMMON-GROUND
- 7 SPEAKER
- 9 +280VOLT@200MA
- 11 +700VOLT@300MA

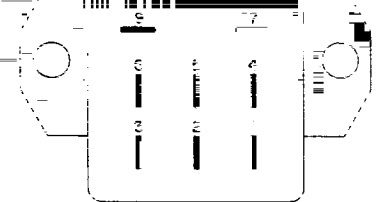

POWER CONNECTIONS

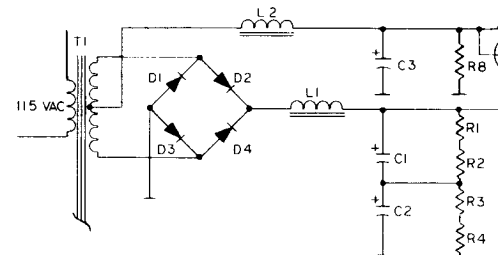
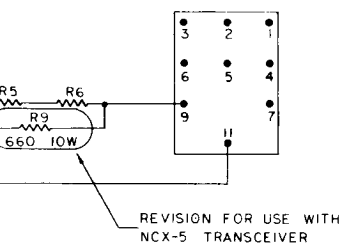

# SECTION 3 OPERATION

## 3.1 TUNING PROCEDURES

### CAUTION!

BEFORE ATTEMPTING TO OPERATE ANY OF THE TRANSCEIVERS, THE FOLLOWING PRELIMINARY CONNECTIONS SHOULD BE MADE:

1. Turn FUNCTION switch from OFF to TUNE position.

2. Adjust PA TUNE and EXCITER TUNE for maximum S-meter reading on background noise.

3. Adjust AUDIO GAIN for comfortable listening level.

3. VOX GAIN, VOX DELAY, CARRIED INSERTION, and MK GAIN should be set as follows:

1. BIAS adjust on rear panel should be set at 12 o'clock.

3.2 TRANSMITTER TUNE-UP (SSB)

**CAUTION**

DO NOT PROLONG TUNE-UP PROCEDURES MORE THAN 30 SECONDS AT A TIME IN ORDER TO PREVENT UNNECESSARY OVERHEATING OF COMPONENTS DURING OUT-OF-RESONANCE CONDITIONS. AFTER EXPERIENCE IS GAINED, TUNE-UP MAY BE ACCOMPLISHED IN A MATTER OF A FEW SECONDS.

1. Turn FUNCTION switch to TUNE and adjust EXCITER TUNE for maximum meter reading.
2. Adjust PA TUNE for minimum meter reading. Do this by increasing the tuning of the PA network. Slowly rotate the PA TUNE control clockwise and observe meter reading with PA TUNE control until meter reads 30C MA.

Set front panel controls as follows:

- TRANSCIVER VECTION (pushed in)
- REF GAIN fully clockwise
- AUDIO GAIN at 9 o'clock
- BAND and MAIN TUNE fully clockwise
- PA TUNE, PA LOAD TUNE fully clockwise
- VOX P.T.U. switch in OFF position
- MOX-TO-E switch in OFF position
- SIDEBAND switch (usually set on bands and USB bands)

- Return FUNCTION switch to SSB. Push the MOX-OFF switch to the MOX position.

**NOTE:**

IF THIS IS THE FIRST TIME THAT THE NCX-5 HAS BEEN PLACED IN OPERATION, THE REAR PANEL BIAS CONTROL SHOULD BE ADJUSTED. THE NCX-5 IS IN TRANSMIT WITH THE MOX-OFF SWITCH IN THE MOX POSITION. THE REAR PANEL BIAS CONTROL SHOULD BE ADJUSTED UNTIL THE METER READS BETWEEN 50 AND 60 MA.

Return the NCX-5 to the receive condition (MOX switch OFF):

**3.1.4 MOX OPERATION**

- The NCX-5 transceiver will now operate in both the transmit and receive modes using the MOX-OFF switch for transmit-receive control.

**3.1.5 VOX OPERATION**

- Place the MOX-OFF switch in the OFF position.
- Place front panel VOX-PTT switch to VOX.
- Turn receiver AUDIO GAIN control (on the front panel) and VOX DELAY control (inside the top cover) clockwise until the meter reads 150 ma.

switch to TUNE and

from SSB operation

switch to AM, press

MOX and rotate the

meter reads 150 ma

until meter just flickers

adjusted for AM opera

detector is automatically

**THE INDIVIDUAL**

s in Section 3.4 of this  
f the NCX-5 for SSB.  
Careful study of the  
help you get the best  
-5 transceiver.

by control from the external push-to-talk switch. The VOX DELAY control remains connected in the PTT mode and may be adjusted for fast or slow return to receive when the push-to-talk button is released.

**3.1.7 CW OPERATION**

- It is assumed that the NCX-5 has been set up for SSB operation and that it is now desired to operate CW.
- Insert Key plug in rear panel jack.
- Turn FUNCTION switch to TUNE and adjust transmitter as for SSB operation.
- Turn FUNCTION switch to CW, depress key, and rotate the CARRIER INSERTION control (inside top cover) clockwise until meter reads 300 ma. Do not continue to rotate the CARRIER INSERTION control beyond this point.
- The NCX-5 is now tuned for CW operation and is ready for full break-in operation. When the key is depressed to start sending, the VOX relay will hold in until the operator stops sending, and then will automatically switch to receive. By adjusting the VOX DELAY control (inside the top cover), the operator may set the "hold-in" relay time to his liking.

**3.1.8 AM OPERATION**

- It is assumed that the NCX-5 has been set up for SSB operation and that it is desired to operate AM.

- Either MOX, VOX, or PTT operation

rotate the VOX GAIN control (inside the top cover) until the relay just trips reliably when speaking into the microphone. Adjust VOX DELAY until VOX relay holds in to the desired time after speaking. These adjustments interact to a small degree and it may be necessary to repeat all adjustments once or twice to optimize results.

Mobile VOX operation is quite easy and practical, but VOX GAIN and MIC GAIN should be adjusted for maximum close-talking to prevent car and wind noises from tripping the relay.

**3.1.6 PTT OPERATION**

- Place the MOX-OFF switch in the OFF position.
- Place the VOX-PTT switch to PTT.
- Connect a suitable push-to-talk switch as shown in figure No. 1. The NCX-5 will operate in both the transmit and receive modes

**3-2 DETAILED USE OF T CONTROLS**

The operating instruction manual enable rapid setup o AM, or CW transmission. following paragraphs will h performance from your NCX

### 3.2.1 MAIN TUNING CONTROL AND DIGITAL DIAL READOUT

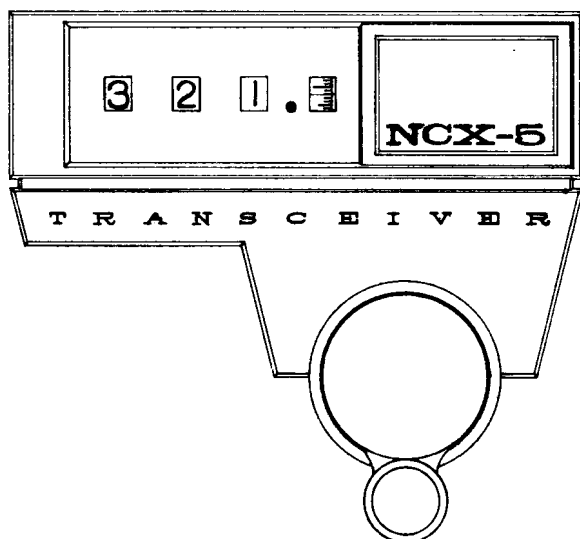

The NCX-5 transceiver incorporates a digital-type direct frequency readout to allow frequency adjustment to 1 Kc without interpolation between divisions. The VFO is accurate to 1 Kc, and it is read by adding the frequency in kilocycles shown on the counter dial to the frequency in megacycles shown on the BANDswitch. With the BANDswitch in the 14.0 Mc position, the frequency as shown in the illustration above is 14.321 Mc. If the BANDswitch were in the 3.5 Mc position, for example, the above frequency would be 3.5 Mc plus 321 Kc, or 3.821 Mc.

To provide even greater resettability, the NCX-5 readout incorporates a fourth window, as shown above, calibrated in ten one-hundred-cycle divisions. The illustration above actually indicates that 321 Kc plus 200 cycles (321.2 Kc) should be added to the BANDswitch frequency.

### 3.2.2 DIAL SET

The dial of the NCX-5 may be adjusted to exact frequency, such as a 100 Kc marker from the optional plug-in XCU-27 calibrator, by tuning to the marker frequency in the receiver and then by pulling *out* the main tuning knob of the NCX-5 and turning the knob until the dial reading corresponds to the known marker frequency.

### 3.2.3 THE FUNCTION SWITCH

Note the various interlocking features of the FUNCTION switch. In the SSB or AM positions of the FUNCTION switch, either VOX, MOX, or PTT operation may be used (see paragraphs 3.2.8 and 3.2.9). The rear panel key jack is disconnected in the SSB or AM positions, thus allowing a key to be left plugged into the NCX-5 at all times. Accidental closing of the key will not trip the unit to transmit if the FUNCTION switch is in either the SSB or AM position.

In the SSB position, the product detector is in use and the CARRIER INSERTION control is disconnected from the balanced modulator circuits. The CARRIER INSERTION control has no effect in the SSB position of the FUNCTION switch and may be preset for either CW or AM operation.

In the AM position, the diode detector is selected. Bias is applied to the carrier oscillator during AM receiving periods, thus silencing the beat frequency oscillator of the receiver. The CARRIER INSERTION control is connected and should be adjusted according to paragraph 3.2.5.

If the front panel FUNCTION switch is in the CW position, the rear panel key jack is connected for automatic break-in operation. At the same time, the plate of the microphone preamplifier is grounded to prevent accidental modulation of the transmitted signal by a microphone connected to the NCX-5. During CW operation, the VOX-PTT switch can be in either the VOX or PTT positions without any effect on the operation of the transceiver. The slight audio "beep" which may be heard from the loudspeaker at the beginning of each keying cycle is the result of the extremely fast attack time of the break-in CW circuit which eliminates "clipping" the first dot. The CARRIER INSERTION control is connected and should be adjusted according to paragraph 3.2.5.

Finally, in the TUNE position of the FUNCTION switch, the keying circuit is internally grounded, placing the NCX-5 in transmit condition. At the same time, full carrier is inserted, and adjustment of the CARRIER INSERTION control has no effect. It is important to note that if the FUNCTION switch is placed in the TUNE position, and an antenna is connected to the NCX-5, full power transmission of a CW note will occur and can cause unwanted interference. Tune-up procedure should therefore be limited to as short a time as possible.

### 3.2.4 THE PA TUNE AND PA LOAD CONTROLS

Adjustment of the PA TUNE and PA LOAD controls is interdependent. For normal tune-up, the FUNCTION switch is placed in the TUNE position. The EXCITER TUNE control is set for maximum meter indication. The PA TUNE control is then set for minimum indication, indicating resonance of the Pi network. For a normal 40 to 60 ohm resistive antenna, the PA LOAD control should be rotated clockwise to increase the meter reading. As this is done, there will be some interaction with the PA TUNE control, and it will be necessary to slightly adjust PA TUNE for minimum meter indication. As the PA LOAD control is advanced, the minimum meter reading will increase. Proper loading for 200 watts peak input occurs at 300 ma (marked in red on the meter scale). This loading current *should not be exceeded*, since the Pi network design is such that additional

power input from a 700 volt supply will *not* result in additional power output. Above 300 ma the efficiency of the NCX-5 final amplifier will be impaired, and no further output will be obtained.

Proper operation of any linear final amplifier depends on proper idling current adjustment and on sufficient drive for adequate peak plate current during an off-resonance condition. The adjustment of the bias setting of the NCX-5 final amplifier is discussed in paragraph 3.1.3. Assuming this setting has been made for an idling current between 50 and 60 ma, it should be possible to obtain a *momentary* maximum off-resonance plate current in excess of 350 ma when the PA TUNE control is rotated away from the point of minimum current. If 700 volts is being properly supplied to the plate circuit of the final amplifier, and the EXCITER TUNE control is properly adjusted, this off-resonance current should exceed 350 ma. If this current cannot be achieved, the cause should be found. Typical causes may include any of the following: improper bias setting, improper EXCITER TUNE adjustment, low plate supply voltage to the final amplifier under full load conditions, low driver B+, defective final amplifier tubes or driver tube, or improper alignment of the exciter stages resulting in low driving signal.

As mentioned above, low plate supply voltage to the final amplifier will frequently result in difficulty in obtaining a suitable off-resonance current. The NCX-A power supply is rated to deliver 700 volts to the final amplifier with a 115 volt A.C. input. The D.C. power supply is rated to deliver 700 volts to the plate circuit of the final amplifier with a 14.0 volt input to the power supply. If the A.C. line voltage or the mobile battery supply voltage is low, the power supply output will be reduced. Under these conditions, an off-resonance plate current of *less* than 350 ma will probably occur. This will not impair the operation of the NCX-5 transmitter, provided that the PA LOAD control is not adjusted for excessive

clockwise position, the antenna load impedance is below 40 ohms. If, on the other hand, the resonant dip is still less than 300 ma with the PA LOAD control rotated to its full clockwise position, the antenna load impedance is above 60 ohms. It is possible to modify the Pi network output capacitors of the NCX-5 to take care of some misloading in these directions. With the PA housing removed, a group of four mica capacitors will be seen just below the BANDswitch and connected between the BANDswitch and chassis. These capacitors, C-37 (3.5 Mc), C-38 (7 Mc), C-39 (14 Mc), and C-182 (21 Mc) are, respectively, 1000, 470, 220, and 220 pF. They appear in parallel with the front panel PA LOAD control as shown on the schematic diagram and may be altered to extend the range of the Pi network. If the load impedance is too low, the capacitance should be increased. A good quality silver mica capacitor may be used for this purpose. It is advisable to use as large a case size on these capacitors as can be obtained.

There is of course some interaction of tuning between the PA LOAD control and the PA TUNE control. If load matching as described in the preceding paragraph is attempted, it is possible that the tuning of the PA TUNE control will be shifted to a point where this control will no longer cover the entire amateur band. In this event, it will be necessary to use external matching techniques. It is also possible that the antenna line will introduce an inductive or capacitive component to the NCX-5 antenna terminals. In this event, there may be also a shift of the PA TUNE control so that it will not tune over the entire amateur band. Again it will be necessary to alter the antenna impedance by means of an external matching network or correction of the antenna difficulties. SSB operation should not be attempted unless the NCX-5 is properly matched and loaded because severe distortion can result with any improperly matched SSB transmitter or receiver.

during an excess (with the TUNING switch in the TUNE position, the CARRIER INSERTION control is in position. Full carrier is automatically inserted. In the AM and CW position, the CARRIER INSERTION control may be preset and will vary the carrier level from zero to full output as indicated by the meter. In the SSB position the CARRIER INSERTION is again inoperative and the carrier suppression is over 50 db at all times.

### 3.2.6 CALIBRATOR CONTROLS

When the accessory XCU-27/100 Kc calibrator is plugged into the local socket on the rear apron, 100 Kc crystal markers are available for precise calibration of the NCX-5. The calibrator is activated by means of a pull-push switch on the AUDIO GAIN control. The dial may then be set by following the instructions in paragraph 3.2.2.

PA TUNE CONTROL

In many instances an antenna does not match the 40 to 50 ohm range of the Pi network used with the NCX-5. Antennas presenting a wide range of impedance should, if at all possible, be adjusted to present a proper load at the NCX-5 antenna terminals. This can be done through the use of Pi networks and, in many instances, by simply adjusting the length of the antenna transmission line to its terminal impedance.

Generally speaking, if the NCX-5 exhibits a resonant plate current in the dip in excess of 350 ma with the PA LOAD control rotated to its full

### 3.2.7 S-METER ADJUSTMENT

Proper S-meter adjustment of the NCX-5 is obtained by disconnecting the antenna and detuning the EXCITER TUNE control while the NCX-5 is set for SSB reception. With the RF GAIN fully clockwise (maximum gain), the S-meter adjustment (in front right corner of chassis) is rotated until the meter indicates between 0 and 1 "S" units.

### 3.2.8 VOX-PTT SWITCH AND VOX CIRCUIT ADJUSTMENTS

The VOX-PTT switch may be set to either mode, depending on preference and availability of a push-to-talk button on the microphone. Proper microphone jack connections are illustrated in figure No. 1.

Assuming that VOX operation is selected, the operator will find that the VOX GAIN and VOX DELAY control settings of the NCX-5 are remarkably free from interaction. The extreme VOX sensitivity available in the NCX-5 permits full anti-vox insertion at all times. As a result, no anti-vox control adjustment is required. With the VOX DELAY control fully ccw, VOX GAIN control is advanced slowly until the microphone just trips the NCX-5 to transmit with normal speech level. Mobile operation requires close talk to the microphone, since the high level of road, wind, and motor noises will otherwise tend to accidentally trip the VOX circuit. The VOX DELAY control is then adjusted for the desired release time.

It should be further noted that PTT and CW break-in operation are obtained through use of the VOX circuit. However, the VOX GAIN control will have no effect on this operation and may be left in any position. The VOX DELAY control is effective on both PTT and CW break-in operation and should be adjusted to the operator's liking for delay at the end of the transmission.

### 3.2.9 THE MOX-OFF SWITCH

The MOX-OFF switch in the MOX (manual operation) position places the NCX-5 in the transmit mode, regardless of the position of the VOX-PTT switch or the FUNCTION switch. This position is useful for manual operation when the microphone is not equipped with a PTT switch. When the MOX-OFF switch is returned to the OFF position, VOX or PTT operation may be selected by the VOX-PTT switch.

### 3.2.10 TRANSCEIVE VERNIER CONTROL

The TRANSCEIVE VERNIER control allows a 5 Kc separation of the receive frequency from the transmit frequency of the NCX-5. It is actuated by pulling the control out and rotating the knob to increase or decrease receiver frequency. The transmit frequency of the NCX-5 remains unchanged at all

times—only the receiver frequency is affected by the TRANSCEIVE VERNIER. The NCX-5 TRANSCEIVE VERNIER will be found to be extremely useful in AM or CW QSO's, as well as in SSB net operation. It allows the operator to tune to the desired AM or CW station with the VERNIER control pushed OFF, thus placing the transmit section of the NCX-5 on frequency. Then the TRANSCEIVE VERNIER can be pulled ON to offset receiver frequency enough to allow tuning of the station to the proper part of the filter passband for best copy without "walking" of the transmit signal.

To escape QRM during a QSO on SSB, the TRANSCEIVE VERNIER can be used to find a clear channel. Once a clear channel is found, the NCX-5 receiver is placed back on frequency simply by pushing the control IN, and arrangements may be made to QSY. The casual listener may also listen to two adjacent QSO's by merely turning the TRANSCEIVE VERNIER control on and off and thereby instantly place the NCX-5 receiver on either frequency.

### 3.2.11 MIC GAIN CONTROL

For SSB operation, set up the NCX-5 by proper tuning of the final amplifier and exciter stages, and advance the MIC GAIN control until the meter reads between 100 and 125 ma on speech content from the microphone. The single sideband audio information so developed has a rapidly varying energy content and the meter will rapidly fluctuate between the 40 to 50 ma idling current and the 100 to 125 ma meter reading. Actual peak current is about 300 ma. This fluctuation will be affected by the nature of the speech content and the individual voice. Generally speaking, the indication will be higher for long drawn out vowel sounds than it is for crisp consonant sounds.

Inclusion of an effective ALC circuit in the NCX-5 has diminished the importance of the microphone gain control. A MIC GAIN control has been provided because of the wide variety of microphones and large variation in output levels even of microphones of the same type. As the MIC GAIN control is rotated from the full ccw position, the current on voice peaks will increase to approximately 125 ma. As MIC GAIN is further increased, little additional change will be noted on the meter. The MIC GAIN control should be set slightly above the point where average current reaches may 125 ma. If the meter is set to the control is advanced well above this point the ALC can no longer handle the drive level and severe distortion may be generated.

For AM operation with the CARRIER INSERTION control set as described in paragraphs 3.1.8 and 3.2.5, there will be a steady meter reading of 150 ma. If the MIC GAIN control is advanced during speech, AM modulation of the final amplifier will occur. When the MIC GAIN control setting

reaches a point where the meter just indicates a slight flicker of speech peaks, modulation is 100%. Operation with the MIC GAIN control above this point should be avoided, since excessive drive will cause clipping of the modulation envelope, and this will result in unwanted spurious transmission outside of the passband of the NCX-5.

### 3.2.12 THE TEN-METER SEGMENT SWITCH

If it is desired to operate on one of the 10-meter segments of the 88.5-29.5 Mc. band, the appropriate 500Kc segment is made by the 10-meter switch concentric with the PA TUNE control. The crystal for the segment from 28.5 to 29.5 is supplied with the NCX-5. If one of the other segments of the band is desired, the appropriate crystal must be plugged in. Sockets are near the existing crystal on the sub-chassis in the front right-hand corner of the NCX-5. The corresponding frequencies and crystals are: 28.0-28.5 Mc segment—crystal frequency 24.5 Mc; 29.0-29.5 Mc segment—crystal frequency 25.5 Mc; and 29.5-30.0 Mc segment—crystal frequency is 26 Mc. These frequencies are also shown on the frequency chart under "Theory of Operation." Ten-meter segment crystals are available from the Service Department of the National Radio Company.

### 3.2.13 CARRIER INSERTION CONTROL AND CARRIER BALANCE

The carrier balance control R-155 of the NCX-5 is internal and has been factory adjusted for proper operation. In order to insure correct operation, the carrier insertion control should be set in the following manner:

Set the FUNCTION switch to SSE. Place the NCX-5 in a transmit condition either by means of the push-to-talk button or by the MOX-OFF switch. In either event, the MIC GAIN control should be in

full ccw position so that no audio modulation will occur. The carrier balance control is then adjusted for minimum meter indication. This meter reading should be between 50 and 60 ma if the BIAS control is properly adjusted. When the carrier balance control is properly set, it may be left in this position for all subsequent operation. A more precise indication of carrier balance control setting may be obtained either by using an oscilloscope connected to the antenna line or by listening to the carrier on a separate receiver with proper carrier balance and tuning the receiver circuits, voltage on the antenna line should not exceed 0.5 volts peak-to-peak as indicated on the oscilloscope.

For AM operation it is necessary to adjust the CARRIER INSERTION control cw from zero until the meter indicates a final amplifier current of 150 ma. This corresponds to approximately 100 watts input to the final amplifier, thus assuring operation of the tubes within their plate dissipation rating.

For CW operation, it is necessary to adjust the CARRIER INSERTION control cw from its zero setting until a meter indication of 300 ma is obtained. This assures an input to the final amplifier of 200 watts during key down transmit conditions of CW operation. Normal keying wave forms approximate a 50% duty cycle; that is, there is full input for about 1/2 of the time and no power for the remaining time. Thus the time-averaged input to the final amplifier is still approximately 100 watts, assuring conservative operation of the final amplifier.

In the SSE position, the CARRIER INSERTION control is inoperative and full carrier suppression is obtained at all times. When the FUNCTION switch is turned to AM or CW, the CARRIER INSERTION control becomes operative and carrier is automatically inserted according to the position of the CARRIER INSERTION control.

**BLOCK DIAGRAM**  
**FIGURE 2**

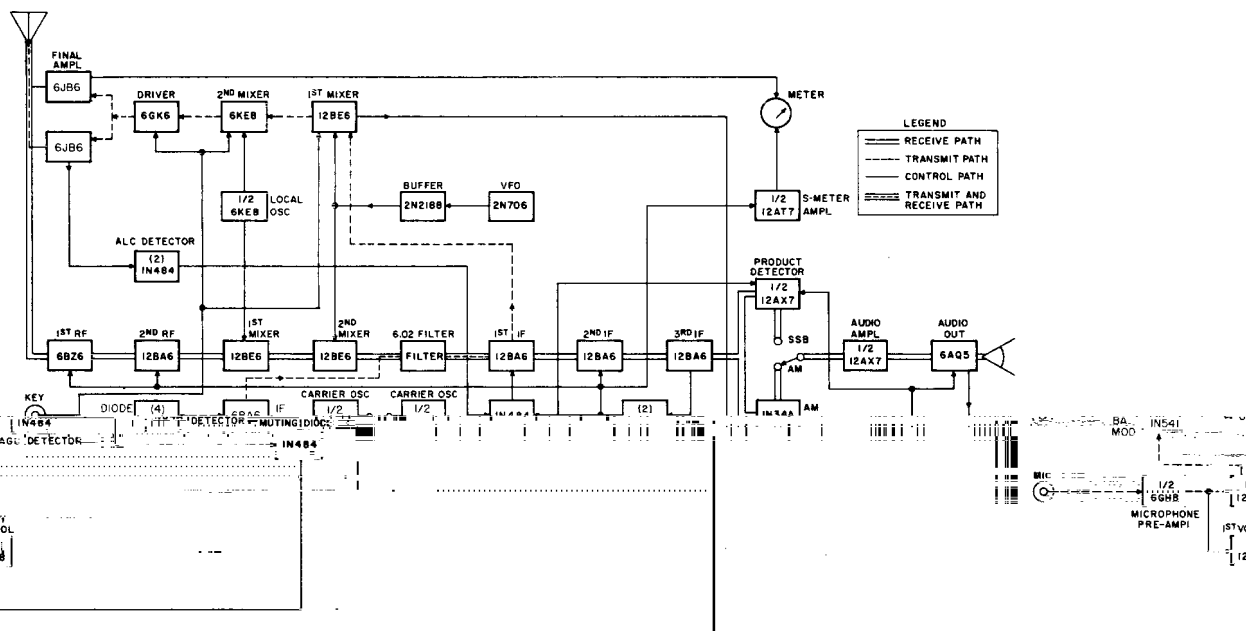

## SECTION 4

### THEORY OF OPERATION

#### 4.1 GENERAL:

The NCX-5 transceiver, designed to cover the 80 through 10 meter amateur bands, combines a double conversion superheterodyne receiver and single conversion transmitter. The VFO consists of a 6N7 tube oscillator and a 2N2188 (Q2) PNP transistor buffer. All biasing resistors and tank circuit capacitors are chosen for low noise and temperature characteristics. Power for the VFO circuits is double-regulated by a zener diode regulator fed from the regulated +150 volt bus. The result is a VFO circuit with a total drift from start-up of less than 100 cycles in any ten-minute period, including variations of external supply voltage and ambient temperature. The main tuning capacitor is completely linear with an accuracy of 1 Kc at any point within the 500 Kc tuning range. Output from the VFO is taken from the collector of the 2N2188 (Q2) and fed to the oscillator grid of the 12BE6 (V3) first transmit mixer.

The output from the first transmit mixer (V3) is always in the 3.5 to 4.0 Mc band. This signal is fed through a bandpass double-tuned circuit to the grid of the pentode section of the 6KE8 (V4B) second transmit mixer. The triode section of the 6KE8 is used as a crystal oscillator which feeds both the second transmit mixer and the first receive mixer.

The plate circuit of the second transmit mixer is single-tuned and feeds the grid of the 6GK6 (V5) driver. The single-tuned plate circuit of the driver feeds the grid of the final amplifier. The coils in the plate circuits of the transmit mixer and driver are band switched for the 80, 40, 20, 15, and 10 meter amateur bands. The tuning gang is tracked so that exciter tuning can be accomplished with only one control. The gains of the transmit mixer and driver are such that a driving signal in excess of 100 volts can be obtained at the grid of the final amplifier, thus assuring linear operation of the exciter well above the level necessary for proper drive.

The final amplifier employs a pair of 6JB6 (V1 and V2) tubes operating in parallel. A bias control on the rear apron sets proper idling current. The plates of the 6JB6 final amplifier are coupled to a high-efficiency Pi network. The band switch selects proper inductance, tuning and lead capacitance to match a 40 to 60 ohm resistive load over the entire 80, 40, 20, 15, and 10 meter amateur bands. The filter used is a double-tuned circuit with a Q of 100.

The crystal lattice filter is resistance terminated and coupled directly to the grid of the 12BA6 (V15) first IF stage. The single-tuned plate circuit is coupled to the grid of the 12BE6 (V3) first transmit mixer.

The crystal lattice filter is resistance terminated and coupled directly to the grid of the 12BA6 (V15) first IF stage. The single-tuned plate circuit is coupled to the grid of the 12BE6 (V3) first transmit mixer. The crystal lattice filter is resistance terminated and coupled directly to the grid of the 12BA6 (V15) first IF stage. The single-tuned plate circuit is coupled to the grid of the 12BE6 (V3) first transmit mixer.

The operation of the NCX-5 is best understood by reference to the block diagram, figure 2, and the frequency chart, figure 3.

#### 4.2 THE TRANSMITTER:

The transmit signal path of the NCX-5 is indicated on the block diagram by a dashed line starting at the mike jack and carrier oscillator. The microphone input circuit is designed for high dynamic or crystal microphones and provides for a push-to-talk microphone circuit. The microphone is connected directly to the grid of the pentode section of a 6GH8 (V8A) tube which operates as a speech amplifier. The signal is then fed through the gain control to one triode section of the 12BE6 (V3) speech amplifier. The plate circuit of the speech amplifier is coupled to the diode balanced

A 12AU7 (V7) tube is used for the oscillator. Each crystal is permanently connected to its triode section, and sideband switching is accomplished by applying a negative bias to the carrier signal. The carrier signal is applied to a common resistive plate load and is fed to a diode balanced modulator. The modulator has both a resistive balance and a capacitive balance. The balanced primary winding of the output transformer is coupled to a single end of the secondary winding which feeds the input of the 6BA6 (V15) IF stage. The transmit IF stage feeds a single-tuned plate circuit. The secondary winding serves as a source of 200 volts for the 12BA6 (V15) IF stage.

approximate of 200 watts input. A small adjustable capacitor coupled from the plate of the 6J6 final amplifier and partially by-passed return of the final grid circuit coils (driven plate coils) provides neutralization. When the final amplifier is properly neutralized, maximum output on a matched antenna will occur at the point of plate current dip, as indicated on the meter.

An effective ALC (automatic level control) circuit is included. If the final amplifier grids are overdriven on voice peaks, the grids will actually see a driving signal positive with respect to the cathodes, and grid current will result. This current will cause a negative voltage change on the bias circuit. The resulting negative voltage change will be coupled to the bias source through a voltage doubling resistor. This resistor will provide a negative D.C. output which is coupled to the grid return of the 12BA6 (V15) first IF amplifier.

When overdrive occurs, the negative voltage doubling resistor will provide a negative D.C. output which is coupled to the grid return of the 12BA6 (V15) first IF amplifier. This negative voltage will result in less driving signal at the final amplifier. Charging takes place rapidly from the low impedance bias source through the rectifying diodes, but the negative ALC voltage cannot discharge through the reverse biased diodes, resulting in a fast attack-slow release action. A gating diode prevents cross connection of the ALC and AGC circuits at the common IF grid return point. The ALC circuit will provide automatic level control for input signal variations of more than 10 db, and makes the setting of the MIC. GAIN control quite noncritical. In addition, sudden changes in voice level or disturbing background noises are all instantly controlled without overdrive and distortion of the NOX transmitter.

### 4.3 THE RECEIVER:

The receiver circuits are indicated by the double solid lines in the block diagram. The receiver RF circuits are common to the transmitter RF circuits. The high-impedance point of the transmitter Pi network is capacitively coupled to the grid of a 6BZ6 (V11) RF amplifier. The tuned circuits at the plate of the transmit driver and plate of the transmit mixer are the input and output circuits of the 12BA6 (V12) second RF amplifier. They provide the receiver RF selectivity and common receiver-transmitter tuning. The output from the second RF amplifier is coupled to the signal grid of the first receive mixer 12BE6 (V13). The oscillator grid is fed from the 6KE8 (V4A) crystal oscillator. The plate of this mixer is coupled to the signal grid of the 12BE6 (V14) second receive mixer. VFO signal is coupled to the oscillator grid of this mixer. The plate circuit of the second receive mixer is connected directly across the secondary of the transmit IF transformer which serves as the input coil to the crystal lattice filter.

The output of the crystal lattice filter, as in the transmitter, couples to the input of a three stage single-tuned IF amplifier operating at approximately 6.02 MC. The detectors and AGC circuits are fed

through separate voltage dividers. The product detector employs one triode of a 12AX7 tube (V18A) with the signal from one IF voltage divider to the grid. A BFO signal is coupled from the crystal controlled 12AU7 (V7) carrier oscillator to the cathode of the product detector, and the resulting audio signal is obtained across a resistive load in the plate circuit. For AM operation, a separate diode detector is connected.

The output from the detectors is coupled to the audio gain control, and then to the grid of the remaining triode section of the 12AX7 (V18) tube functioning as a grid-leak biased, first audio amplifier. The plate circuit is coupled to the grid of the 6AQ5 (V19) audio output stage. The audio output stage leads to output transformer having a 3.2 ohm secondary. This output signal is also available at the phone jack. The low-impedance nature of the phone jack is compensated by the use of a 15W-000 phone.

A secondary feed is obtained from the output of the last IF amplifier and is fed to a doubling AGC rectifier. The low-impedance source provides a rapid charge of the AGC. When the signal disappears, the negative AGC cannot discharge through the diodes, which has a long release time, thus giving the AGC a selective fast-attack slow-release action. The feed to the grid of the remaining half of the (V6B) S-meter amplifier. AGC is connected through the gating diode to the first IF control.

### 4.4 THE VOX CIRCUITS

Before considering the switching operation, we must first discuss the VOX circuits.

The signal which trips the relay from transmit is derived from two sources. The first is the VOX signal which is picked up after the phone preamplifier and separately amplified by a two stage amplifier consisting of V9A and V9B (12AU7). The other signal is derived from the detector circuit and is called the ANT-VOX signal.

Both signals are rectified, the VOX signal to make a negative voltage, the ANT-VOX signal to make a positive voltage. The two D.C. voltages are applied in series to the grid of the relay control tube. The circuit constants in the VOX and ANT-VOX detectors are arranged so that the D.C. voltage derived from the ANT-VOX detector is always larger than the voltage generated in the VOX channel from loudspeaker information.

Additional information entering the microphone is amplified through the VOX amplifier and will develop enough negative voltage at the grid of the relay control tube to let the relay fall off and place the circuit in transmit position.

The VOX and ANTI-VOX detector time constants are so arranged that the circuits will drive the relay tube grid negative in a very short time. At the end of transmission, the relay control signal cannot discharge backwards through the diodes. The discharge time is controlled by R7, the DELAY control which can be set from a fraction of a second to several seconds. This circuit is also used in the CW position and will be discussed later.

#### 4.5 THE FUNCTION SWITCHES:

The following paragraphs describe the operation

of the first transmit mixer. The screen of this mixer tube V3 (12BE6) will now draw current, causing a reduction of screen voltage. A voltage divider connected from this screen to the -80 bias line will develop a negative signal which is tied through the VOX-PTT and the MOX switch to the keying and PTT diode. The keying and PTT diode feeds the grid of the relay tube. The relay tube will be biased off, the relay falls out, and the set is in transmitting position.

The negative signal developed at the first transmit mixer screen is also fed to the product detector and audio output amplifier for quiet switching.

On release of the push to talk button, the negative bias reverts to normal. The relay tube is pulled in.

#### 4.5.1 FUNCTION SWITCH OFF

In this position the FUNCTION switch interrupts the primary power, either directly in case of the NCX-A power supply or through a remote relay in the NCX-D 12-volt D.C. supply. The position of all other switches becomes irrelevant.

#### 4.5.2 FUNCTION SWITCH SSB

In this position the following circuits are set up: The VOX-PTT switch, the product detector, and the microphone amplifier are connected into the circuit. The key jack is disconnected to prevent accidental keying. The CARRIER INSERTION control is disconnected and a negative bias is applied to the 6BA6 (V.10) transmit IF stage to reduce gain.

Now three different types of operation are possible:

#### 4.5.2.1 VOX OPERATION

VOX switch in VOX position and the MOX-OFF switch in OFF position. In this combination the VOX and MOX switches ground the keying diode. Voice information from the microphone will override the ANTI-VOX, as described before, tripping the relay. The relay will transfer B++ to the final and other transmitting tubes. Negative bias is removed from various transmitting tubes and applied to receiving tubes and the first audio amplifier for quiet switch over. At the end of transmission and after the preset DELAY the relay will pull in again and the set is in receiving condition.

#### 4.5.2.2 PUSH TO TALK OPERATION

VOX-PTT switch on PTT, MOX-OFF switch on OFF position. The output of the VOX amplifier is now shunted to ground, and the push-to-talk contact is connected across the transmit bias line. When the push-to-talk contact is pushed, the bias line (135) is grounded, which removes the disabling bias from transmitting tubes. The bias is also removed from the

predetermined time. Effective break-in keying is therefore realized. The VOX-PTT circuits are disabled so that the microphone can be left in its jack. The MOX switch, however, will still actuate the transmitter.

#### 4.5.5 FUNCTION SWITCH IN TUNE POSITION

In this position the FUNCTION switch will ground the transmitter bias line, placing the transmitter into operation, as described under "SSB-PTT Operation" (paragraph 4.5.2.2) and ground one of the balanced modulator deflection plates, providing a strong signal through the system. The MOX, VOX, PTT, and key circuits are disabled and have no influence on the tuning procedure. In this position, the center arm of the CARRIER INSERTION control is switched to the top of the control, providing an unbalanced condition. The bias on V-10 is still at zero. This provides for more than adequate drive for the tune-up condition.

#### 4.6 RELAY FUNCTIONS:

In the foregoing discussion, the exact nature of the relay switching was not described. The six-pole double-throw relay is actuated by the plate current of the 6GH8 relay tube V8B. The NCX-5 is placed in a transmit condition when the relay is de-energized.

The first set of contacts, 5, 6, and 7, transfers +220 volts between transmit and receiving functions.

Contacts 8, 9, and 10 transfer the bias on the varactor diode in the VFO. This varactor is actuated by a bias depending on the setting and switching of the TRANSCEIVE VERNIER control during receiving periods and by a fixed bias during transmitting periods.

Contacts 11 and 12 are closed during transmit and are brought out on the rear apron of the NCX-5 for operation of the NCL-2000 linear amplifier.

Contacts 14, 15, and 16 operate as follows: The relay arm, contact 15, grounds the AGC line of the receiver at contact 14 to prevent excessive AGC build-up during transmit periods and to assure a prompt recovery of the receiver when required. Contact 15 grounds the screens of the final amplifier at contact 16, during receiving periods.

Contacts 17, 18, and 19 also are grounding contacts: the arm, contact 18 connects the meter at contact 17 to read the final cathode current during transmit periods; contact 19, grounded during receiving periods, is connected to the accessory socket for operation of the external VX-501 console.

Contacts 20, 21, and 22 ground the bias line either for receive or transmit, placing the appropriate tubes into operation as desired.

Final Output Transmit Driver Second Transmit Mixer Receiver RF Amplifier Receiver Mixer Input		3.5-4	7-7.5	14-14.5	21-21.5	28-28.5	28.5-29	29-29.5	29.5-30
Crystal Osc.		None	11	18	25	24.5	25	25.5	26
First Transmit Mixer Output		3.5-4	4-3.5	4-3.5	4-3.5	3.5-4	3.5-4	3.5-4	3.5-4
First Receive Mixer Output									
VFO	USB	9.5236 10.0236	10.02 9.52	10.02 9.52	10.02 9.52	9.5236 10.0236	9.5236 10.0236	9.5236 10.0236	9.5236 10.0236
	LSB	9.52 10.0236	10.0236 9.52	10.0236 9.52	10.0236 9.52	9.52 10.0236	9.52 10.0236	9.52 10.0236	9.52 10.0236
Carrier Osc.	USB	6.0236	6.02	6.02	6.02	6.0236	6.0236	6.0236	6.0236
Second Receive Mixer Output									
Receiver IF	LSB	6.02	6.0236	6.0236	6.0236	6.02	6.02	6.02	6.02

FREQUENCY CHART

FIGURE 3

## SECTION 5

### NCX-5 TEST AND ALIGNMENT

**NOTE:**

TEST AND ALIGNMENT OF THE NCX-5 SHOULD ONLY BE PERFORMED BY COMPETENT, QUALIFIED PERSONNEL.

#### 5.1 EQUIPMENT REQUIRED:

1. Signal generator providing output at the following frequencies: 6.0218 Mc, 3.5 Mc, 4 Mc, 7 Mc, 7.3 Mc, 14.0 Mc, 14.4 Mc, 21.0 Mc, 21.5 Mc, 28.0 Mc, 28.5 Mc, 29 Mc, 29.5 Mc.
2. Vacuum tube voltmeter (VTVM).
3. Standard output meter.
4. Sweep generator capable of sweeping at approximately 60 cycles per second over a frequency range from approximately 3 to 4.5 Mc.
5. High-frequency oscilloscope covering the range from DC to 30 Mc with a maximum sensitivity of 50 mv per centimeter or better and a low capacity input probe (Tektronix type 545 with type L preamplifier or equivalent).
6. External receiver capable of receiving at 9.72 Mc.

#### 5.2 INITIAL CONTROL SETTINGS:

##### FRONT PANEL

RF and AF GAIN	Full cw
FUNCTION Switch	OFF
PA TUNE	Full cw
PA LOAD and EXCITER TUNE	Full cw
BANDSWITCH	3.5 Mc
TRANSCIVE VERNIER	OFF
SIDEBAND Switch	USB
10-METER Switch	28.5 Mc
MOX-OFF Switch	OFF
VOX-PTT Switch	PTT

##### REAR PANEL

BIAS	Mid-range
------	-----------

##### INSIDE TOP COVER

MIC GAIN	Full cw
CARRIER INSERTION	Full cw
VOX GAIN	Full cw
VOX DELAY	Full cw

##### Power Connections:

Connect the power supply with the 700 volt output turned off. The heater wire connecting the two 6GJ5 sockets should be removed.

#### ALIGNMENT PROCEDURE:

FUNCTION switch to CW in a few seconds the meter should close, indicating that the receive condition.

the audio output meter to the speaker can be conveniently done by plugging the meter into the phone jack. Connect the meter through a 1000 pF capacitor to the output of the 12BE6 (V-14) second receiver signal generator for output at 6.0218 Mc. A beat note should be heard. Align the first, second, and third IF transformers (T-6), as well as the bottom slug of the IF transformer (T-1) for maximum sensitivity. Careful to avoid overload of the receiver. The signal generator output should be adjusted throughout this alignment procedure so that the power of 100 mw is never exceeded.

meter covering the frequency range from 3.5 to 30 Mc. (A high frequency vacuum tube voltmeter with a 100 volt full scale range may be substituted for the calibrated output power meter.)

8. Power supply capable of supplying +700 volts at 300 ma, +280 volts at 200 ma and -80 volts at 6 ma.

9. 1000 cycle audio generator with an output level of 10 mv.

10. High quality microphone equipped with push-to-talk button.

11. Transmitting key.

12. Suitable alignment tools for adjustment of coils and capacitors.

13. XCU-27 crystal calibrator.

Connect the power supply with the 700 volt output turned off. The heater wire connecting the two 6GJ5 sockets should be removed.

Turn the second receiver signal generator to 6.0218 Mc. A 1 to 2K slugs of the first IF transformer (T-4, T-5, and the transmit output, being receiving channel should be reduced that an output

#### 5.4 BALANCED MODULATOR ADJUSTMENT:

Connect the high-frequency oscilloscope to the grid (Pin 1) of the first IF amplifier 12BA6 (V-15). Place the MOX-OFF switch in MOX position. The relay in the NCX-5 should open, placing the unit in a transmit condition. Adjust the top and bottom slugs of transmit IF output transformer (T-1) and the slug in the Balanced Modulator transformer (T-6) for maximum indication on the scope. This should occur near mid-range on the control.

#### 5.5 CARRIER OSCILLATOR SETTING:

Place the FUNCTION switch in the TUNE position with connections set as for balanced modulator adjustment, adjust (C-6) corresponding to the 6.0234 Mc crystal until the signal level is 0.2 volts peak-to-peak as indicated on the oscilloscope.

Set the SIDEBAND switch to LSB. Adjust (C-5) corresponding to the 6.020 Mc crystal until the signal level is 0.7 volts peak-to-peak as indicated on the oscilloscope.

Return the FUNCTION switch to SSB, return the SIDEBAND switch to USB, remove the oscilloscope connection and return MOX-OFF switch to OFF.

#### 5.6 TRANSMITTER BANDPASS TUNING:

Connect the sweep generator to the signal grid (Pin 7) of the first transmit mixer 12BE6 (V-3). Connect the oscilloscope to the junction of C-134, R-76, and the cable feeding the grid of the second transmit mixer. Press the MOX-OFF switch to MOX. The CARRIER INSERTION control may be adjusted for minimum carrier to avoid unwanted oscilloscope indications. Adjust the top and bottom slugs of the transmit bandpass coil (T-2) for maximum display amplitude and proper response. The 3.5 and 4.0 Mc outputs of the signal generator may be used as marker frequencies. When properly aligned, the oscilloscope display should be as indicated.

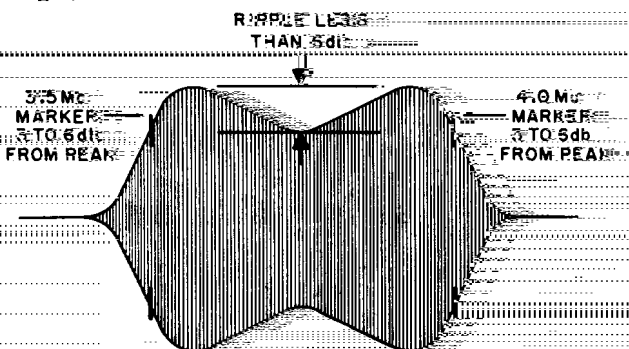

Return MOX-OFF switch to OFF and disconnect oscilloscope and sweep generator leads.

#### 5.7 RECEIVER BANDPASS TUNING:

Connect the sweep generator to the signal grid (Pin 7) of the first receive mixer 12BE6 (V-13). Connect the oscilloscope to the signal grid (Pin 7) of the second receive mixer 12BE6 (V-14). Adjust the top and bottom slugs of the receiver bandpass coil (T-3) for maximum display amplitude and proper response similar to that obtained for the transmit bandpass coil. Disconnect the oscilloscope and sweep generator connections.

#### 5.8 VFO FREQUENCY ALIGNMENT:

Connect the high frequency signal generator to the signal grid (Pin 7) of the first transmit mixer 12BE6 (V-13). Preset the sideband switching trimmer (C-16) and the temperature compensating trimmer (C-18) to mid-range. Set the signal generator frequency to 4 Mc. Adjust the VFO coil (L-27) for zero beat. Set the generator input to 3.5 Mc and tune the main tuning dial toward 3.5 Mc. A beat note should be obtained in the region of 3.5 Mc on the dial. If this beat note occurs at a dial setting above 3.5 Mc, the VFO trimmer (C-17) should be turned to reduce the capacity. If the beat note occurs below 3.5 Mc on the dial, increase the trimmer capacity. Return the signal generator and main tuning dial to 4 Mc. Reset the VFO coil slug for zero beat and again observe the location of the beat note near 3.5 Mc with the signal generator set to 3.5 Mc. This procedure should be repeated until the 3.5 Mc beat note and the 4.0 Mc beat note occur within 500 cycles of the dial markings.

#### 5.9 VFO LINEARITY ADJUSTMENT:

A special linearity adjustment (consisting of two segmented plates and a stator) is incorporated in the rear section of the NCX-5 VFO capacitor. After adjustment of the VFO frequency at 4.0 and 3.5 Mc, it may be necessary to set the VFO linearity.

Insert the crystal calibrator into the crystal calibrator socket. With the crystal calibrator turned on and set for 100 Kc markers, it should be possible to obtain a zero beat at the 3.5 and 4.0 Mc points which have previously been set. The main tuning should now be adjusted to 3.5, 3.7, and 3.5 Mc. At each of these points zero beat should occur within  $\pm 500$  cycles of the exact dial frequency. If necessary, one (or both) of the segmented adjusting plates should be bent as required to achieve proper calibration. If the indicated frequency is too low at the zero beat point, one or both of the plates should be moved toward the stator. If the indicated dial reading at zero beat is too high, the plate should be moved away from the stator. It is important that this linearity correction be made on a gradual basis. The entire correction at any one point should not be made with a single segment of the correction plate. When properly aligned, the corrector segments will lie in a smooth curve.

## 5.10 VFO SIDEBAND SWITCHING ADJUSTMENT:

Set the main tuning to zero beat at 3.8 Mc, rotate the sideband selector switch to LSB. The frequency obtained should still be zero beat. If it is not, set the sideband trimmer (C-16) for zero beat. As the sideband selector switch is rotated from LSB to USB, there should be no change of frequency. There is a small interaction of this adjustment with the VFO alignment. The VFO alignment should be readjusted if any error is introduced.

## 5.11 TEMPERATURE COMPENSATING ADJUSTMENT:

During alignment of the NCX-5, its VFO should be checked. If drift is excessive, the temperature compensating capacitor should be adjusted to provide greater or less compensation. Drift towards a lower dial reading on 80 meters indicates excessive temperature compensation and the compensating trimmer (C-18) should be turned to reduce capacity. A drift toward a higher dial reading indicates insufficient compensation and the trimmer should be turned for greater capacity. Adjustment of the compensating trimmer will change the VFO frequency. Complete readjustment of the VFO should be provided by the following procedure: Set the NCX-5 to zero beat at 3.8 Mc dial setting. Adjust the compensating trimmer as required and immediately adjust the VFO trimmer (C-17) to return the NCX-5 to zero beat. If this procedure is carefully followed, the dial calibration should not be seriously affected. If a major correction has been made, the dial calibration should be checked and the alignment of the preceding sections should be repeated if necessary. Disconnect the signal generator leads from the NCX-5.

## 5.12 TRANSMIT MIXER AND DRIVER ALIGNMENT:

Connect the high-frequency oscilloscope to the junction of C-46, R-42, and the grids of the 6GJ5 final amplifier. Set the BAND switch to 3.5 Mc and the FUNCTION switch to TUNE. The relay should again drop out, indicating that the unit has been placed in a transmit condition. Set the main tuning dial to 3.750 Mc and the EXCITER control to 5. Adjust the 80 meter mixer coil (L-10) and the 80 meter driver coil (L-5) slugs for maximum indication on the oscilloscope. When the slugs are properly adjusted, the peak-to-peak output voltage on the oscilloscope should exceed 130 volts.

Set the BAND switch to 7.0 Mc and the EXCITER TUNE control to 6. Repeat the above procedure at 7.300 Mc while adjusting the 40 meter mixer coil (L-9) and the 40 meter driver coil (L-4). An output of more than 130 volts peak-to-peak must be indicated on the oscilloscope.

At this point a ripple will appear on the oscilloscope pattern. Adjust the harmonic trap (L-29) to minimize this ripple. After this adjustment is made, there will be some interaction with the tuning of the 40 meter mixer coil (L-9) which must be readjusted for maximum amplitude. Repeat these adjustments until minimum ripple and maximum amplitude are obtained simultaneously. The setting of the harmonic trap may be checked by removing the 11 Mc crystal in the high-frequency oscillator circuit. When the crystal is removed, there should be a large drop in the amplitude of the oscilloscope display. If there is no such drop, the harmonic trap has been mistuned and the slug should be withdrawn from the coil and the above alignment procedure repeated on the proper trap frequency.

Set the BAND switch to 14.0 Mc and the EXCITER TUNE control to 3. Repeat the above procedure at 14.250 Mc while adjusting the 20 meter mixer coil (L-8) and the 20 meter driver coil (L-3).

Set the BAND switch to 21.0 Mc and the EXCITER TUNE control to 7. Repeat the above procedure at 21.250 Mc while adjusting the 15 meter mixer coil (L-7) and the 15 meter driver coil (L-2).

Set the BAND switch to 28.5 Mc and the EXCITER TUNE control to 7. Repeat the above procedure at 28.750 Mc while adjusting the 10 meter mixer coil (L-6) and the 10 meter driver coil (L-1).

## 5.13 FINAL AMPLIFIER PRELIMINARY ADJUSTMENT (10 METER):

The NCX-5 construction does not provide for any alignment of the final amplifier. It is necessary at this time to check the final amplifier for proper operation at the high and low ends of all bands. In addition, it is necessary to make a slight final adjustment on the driver plate coils and on the neutralizing capacitor. These checks should be made in the following sequence: Connect the heater wire between the 6JB6 sockets. Place the FUNCTION switch in the CW position and allow approximately 30 seconds for warm-up of the final amplifier tubes.

### — CAUTION —

UP UNTIL THIS TIME, THERE HAS BEEN NO POWER APPLIED TO THE FINAL AMPLIFIER. ALL CIRCUITS WHICH HAVE BEEN OPERATING AND WHICH HAVE BEEN TESTED ARE LOW LEVEL CIRCUITS USING VOLTAGES AND POWER NORMALLY ENCOUNTERED IN DAY-TO-DAY RECEIVER WORK. FROM HERE ON, VOLTAGES AND CURRENTS MAY BE ENCOUNTERED WHICH ARE DANGEROUS TO PERSONNEL AND TO THE TEST EQUIPMENT AND THE UNIT UNDER TEST. IT IS ESSENTIAL TO BE SURE THAT NO PIECE OF TEST EQUIPMENT BE MISCONNECTED INTENTIONALLY OR ACCIDENTALLY TO THE NCX-5. IT IS FURTHER

IMPORTANT THAT PERSONNEL BE CAUTIONED AGAINST CARELESS HANDLING WHICH MAY RESULT IN CONTACT WITH DANGEROUS VOLTAGES. IT IS FURTHER IMPORTANT THAT THE NCX-5 NOT BE PLACED INTO A TRANSMITTING CONDITION WITHOUT PROPER TUNING, SINCE DAMAGE MAY RAPIDLY RESULT TO THE NCX-5. IN A NUMBER OF THE FOLLOWING TESTS THE TRANSMITTER WILL BE OPERATED AT FULL POWER OUTPUT. IF MISINDICATIONS ARE OBTAINED, OR IF THE TEST IS NOT COMPLETED WITHIN A PERIOD OF 15 SECONDS, OR IF THE UNIT IS NOT TUNED UP WITHIN A PERIOD OF 15 SECONDS, IT IS IMPORTANT THAT THE UNIT BE RETURNED TO A RECEIVING CONDITION. OTHERWISE, SERIOUS AND PERMANENT DAMAGE CAN BE DONE TO THE FINAL AMPLIFIER TUBES AND COMPONENTS IN THE FINAL OUTPUT CIRCUIT.

Disconnect all test equipment from the NCX-5. Attach the 50 ohm dummy load with calibrated output meter to the NCX-5 antenna terminals. With a D.C. voltmeter, set the bias at the grid of the final amplifier for maximum negative voltage. With the BAND switch still on the 28.5 Mc band, set the main tuning dial to 28.75 Mc. Now turn the FUNCTION switch to TUNE and rapidly peak the EXCITER TUNE for maximum meter reading on the combination S-meter and cathode current meter. Adjust the 10 meter driver plate coil (L-1) for maximum meter reading while slowly rocking the EXCITER TUNE control. This will correct for the presence of the oscilloscope probe in the previous setting. Now rotate the PA TUNE control and observe whether a dip occurs in the plate current reading.

Note the power output recorded by the power output meter. This power output should exceed 100 watts at all frequencies providing the PA LOAD control is adjusted so that the final amplifier draws 300 ma. With the PA TUNE control set for a plate current dip, the PA LOAD control is slowly rotated in a clockwise direction. As the PA LOAD control is advanced, it will be necessary to slightly retune the PA TUNE control to stay in the dip. Continue this process until the minimum reading in the dip corresponds to 300 ma on the meter.

#### 5.14 NEUTRALIZING CAPACITOR:

With the FUNCTION switch in the TUNE position, rotate the PA TUNE control to either side of the resonant point and observe the plate current meter. It is necessary that the off resonance current exceed 350 ma. Having noted the off resonance plate current, retune the PA TUNE control to the plate current dip at 300 ma and observe the power output. It should exceed 100 watts. Carefully rotate the PA

TUNE control to either side of the dip and observe whether the power output rises or falls. With a proper setting of the neutralizing capacitor, the power output should fall to either side of the dip. If the power output actually rises as the tuning control is tuned away from the dip, it will be necessary to adjust the neutralizing capacitor. This can be quickly done on a trial and error basis by rotating the neutralizing capacitor and observing whether maximum power output occurs at the plate current dip. As proper neutralization is achieved, maximum power output will occur at minimum plate current. Return the FUNCTION switch to CW.

#### 5.15 FINAL AMPLIFIER PRELIMINARY ADJUSTMENT (80-15 METERS):

Set the BAND switch to 21 Mc and the main tuning dial to 21.250 Mc. Turn the FUNCTION switch to TUNE and rapidly peak the EXCITER TUNE for maximum meter reading. Adjust the 15 meter driver plate coil (L-2) for maximum meter reading while slowly rocking the EXCITER TUNE control. This will correct for the presence of the oscilloscope probe in previous tests. Now rotate the PA TUNE control and observe whether a dip appears in the reading. Advance the PA LOAD in a clockwise direction and slightly retune the PA TUNE control to stay in dip. Continue this process until the minimum meter reading in the dip corresponds to 300 ma. The power output should exceed 100 watts and proper neutralization should be observed.

Repeat this procedure at the following BAND switch and tuning settings, in each case adjusting the proper driver coil for maximum meter indication while rocking the EXCITER TUNE control.

MAIN		
BANDSWITCH	TUNING DIAL	DRIVER COIL
14 Mc	14.250 Mc	L-3
7 Mc	7.250 Mc	L-4
3.5 Mc	3.750 Mc	L-5

#### 5.16 FINAL AMPLIFIER TUNING CHECKS:

The proper crystal should be inserted into the NCX-5 high frequency oscillator for operation at BAND switch settings of 28, 29, and 29.5 Mc. If these crystals are not available, final amplifier tuning checks in these BAND switch settings cannot be made.

Set the BAND switch to 28.0 Mc. Set the main tuning dial to 28.250 Mc. Turn the FUNCTION switch to TUNE and peak the EXCITER TUNE for maximum meter reading. Rotate the PA TUNE control and observe whether a dip appears in the reading. Advance the PA LOAD control in a clockwise direction and retune the PA TUNE control to maintain the output circuit in the dip. Continue this procedure until the minimum reading in the dip corresponds to 300 ma on the meter. Power output at this setting should exceed 100 watts and proper neutralization should be observed.

Repeat this check with BAND switch and main tuning capacitor set for the following frequencies. If necessary, mixer and IFT sockets may be slightly re-adjusted to maintain proper tracking across the band, providing sufficient drive and proper final amplifier operation is achieved.

BANDSWITCH	MAIN TUNING DIAL
20 Mc	29.25 Mc
20.5 Mc	29.75 Mc
21.0 Mc	21.00 Mc
21.0 Mc	21.50 Mc
14.0 Mc	14.00 Mc
14.0 Mc	14.50 Mc
7.0 Mc	7.00 Mc
7.0 Mc	7.30 Mc
3.5 Mc	3.50 Mc
3.5 Mc	4.00 Mc

### 5.17 LOCAL OSCILLATOR CRYSTAL ADJUSTMENT:

Set the BAND switch to 7.0 Mc. Turn the crystal calibrator ON. Tune to any crystal calibrator signal. The dial should read an exact 100 Kc point. We adjust the crystal trimmer (C-9) and the main tuning dial to set both beat notes to zero.

Repeat this procedure on the 14.0 Mc band and set the 18 Mc crystal trimmer (C-10).

Repeat this procedure on the 21.0 Mc band and set the 23 Mc crystal trimmer (C-10).

The accessory crystal trimmers may also be set by this procedure according to the following chart:

BAND SWITCH	SEGMENT	TRIMMER
28.0 Mc	28.0 Mc	C-14
28.0 Mc	29.0 Mc	C-15
28.0 Mc	29.5 Mc	C-12

### 5.18 PARASITIC CHECK

Set the FUNCTION switch to SSB. Press the MOX OFF switch to MOX. Adjust CARRIER BALANCE control for minimum current. Tune PA TUNE PA LOAD and EXCITER controls through their ranges. Look for unwanted spurious peaks on the meter. There should be none. Repeat this test on all bands.

### 5.19 CARRIER SUPPRESSION, SIDEBAND SUPPRESSION, MODULATION, AND ALC CHECKS:

Connect the audio generator to the microphone

input as described in the previous sections. A level well in excess of 100 volts peak-to-peak should be observed on the oscilloscope. Turn the FUNCTION switch to the SSB position. Set the carrier balance control for minimum indication on the oscilloscope when scale corresponds to minimum indication on the meter. Adjust the BIAS control to 60 ma on the meter. The level remaining on the oscilloscope should not exceed 0.5 volt peak-to-peak, thus insuring carrier suppressor better than 60 db. If necessary, carefully adjust the balanced modulator phase trimmer (C-7) for minimum indication while rocking the carrier balance control through minimum until the required 0.5 volt level is obtained.

Now rotate the MIC GAIN control slowly in a clockwise direction. A signal should again appear on the oscilloscope. The MIC GAIN should be advanced until the cathode current meter reads 250 ma. Output at the scope should be 120-180 volts. The wave form at this point should appear as indicated in figure 6A. It is necessary to note the level of ripple on the wave form to total wave form level. The ripple should not exceed 1/50 of the total wave form. This indicates that the unwanted sideband suppression with a 1000 cps tone is in excess of 54 db. The limit of this measuring technique:

It is important to note the difference between carrier balance and unwanted sideband suppression in the previous measurement. If the carrier balance control is rotated slightly, the wave form of figure 6A will be altered to the wave form of figure 6B. If this wave form is present while attempting to make the sideband suppression measurement, the carrier balance

control should be rotated until the wave form returns to that of figure 6A.

Place the FUNCTION switch in the AM position. Now further advance the MIC GAIN until the meter just reaches 300 ma as set by our previous tuning procedure. Note the scale on the level. Slowly advance the CARRIER INSERTION control. As the minimum setting. As this occurs the wave form will begin to develop large cusps and peaks which will tend to exceed the noted oscilloscope level. Slowly reduce the MIC GAIN to keep the peaks at the predetermined level by carefully adjusting both the MIC GAIN and the CARRIER INSERTION control. It should be possible to obtain a picture as illustrated in figure 6C. It is important that the peaks of this figure be at exactly the level determined with the balanced carrier at 300 ma of cathode current. This is equivalent to a two-tone test and is useful in indicating distortion in the transmitter channel and performance of the modulating circuits. The wave

form should be as shown in figure 6C. Connect the high frequency oscilloscope

Advance the MIC GAIN control to maximum and readjust the CARRIER INSERTION control for sharp cusps. The final amplifier should now be overdriven and ALC voltage should result. The oscilloscope wave form should remain as shown in figure 6C. Check the ALC output at the junction of D-9, R-34, R-35, and C-48. There should be approximately -5 volts at this point. Check the ALC voltage at the junction of D-8, D-9, and C-50. The voltage at this point should be 1/2 of the previous reading. This checks the action of the internal ALC circuit.

The rear ALC jack may now be checked by applying -10 to -15 volts at the ALC input jack. The oscilloscope display amplitude should decrease, indicating external control.

Press the MOX-OFF switch to OFF and set the VOX-PTT switch to PTT.

If all of the tests are met satisfactorily, we can assume that the transmitter is working properly, although minor adjustments may be necessary. Turn the rear MIC GAIN to zero and place the FUNCTION switch in the SSB position. Now remove the audio generator from the microphone jack and replace it with the test microphone. Press the push-to-talk button and speak normally into the microphone. Slowly advance the MIC GAIN control until the peak of the resulting signal reaches the amplitude used for the previous two-tone type test. At this point the meter will be fluctuating rapidly with the speech content. The meter should generally average around 125 ma of current and the output wave form should appear as illustrated in figure 6F.

**5.20 TRANSMIT-RECEIVE FREQUENCY CHECK:**

Set the BAND switch to 3.5 Mc and the dial to 3.700 Mc. Tune the final amplifier using the TUNE function. Return the FUNCTION switch to CW and press the MOX-OFF switch to MOX. Return the MIC GAIN control to the full cw position. Now rotate the CARRIER INSERTION control until 300 ma is indicated on the meter and output appears on the oscilloscope. Press the MOX-OFF switch OFF. Tune an accessory receiver to 9.72 Mc and couple lightly to the NCX-5 VEO. A beat note should be noted. Press the MOX-OFF switch to MOX. The

beat note indicated by the accessory receiver should not change more than 50 cycles. Press the MOX-OFF switch OFF.

**5.21 LSB-USB SWITCHING CHECK:**

Proper sideband switching may be easily checked with the D.C. voltmeter according to the chart below.

**5.22 SWITCHING TESTS:**

The transmitter portion of the NCX-5 is presently connected to a dummy load with an oscilloscope. Tune the NCX-5 to resonance for maximum power output. Balance the carrier. With these conditions established, now check the entire switching sequence in the following manner:

- Place the FUNCTION switch in SSB, the PTT-VOX switch in the PTT position, and MOX-OFF switch OFF. Press the push-to-talk button and speak into the microphone. A standard single sideband output should appear on the oscilloscope. Release the push-to-talk button. The NCX-5 should revert to receive. Press the MOX-OFF switch to MOX and speak into the microphone. SSB output should result. Return the MOX-OFF switch OFF and the NCX-5 should revert to receive.
- Place the VOX-PTT switch in the VOX position. While speaking into the microphone, slowly advance the VOX GAIN control until the relay trips the unit into transmit. Stop speaking and the transceiver should return to receive. While speaking into the microphone to cause the NCX-5 to transmit, adjust the DELAY control full ccw, stop speaking, and the NCX-5 should go back to receive in approximately 1/10 of a second.
- Turn the DELAY control full cw and speak into the microphone. The NCX-5 should switch to transmit; stop speaking and the NCX-5 should return to receive in one second. In each case, a standard single-sideband signal should be observed on the

TEST POINT	LSB					USB				
BAND	3.5	7.0	14.0	21.0	28.0	3.5	7.0	14.0	21.0	28.0
1	+150	-35	-35	-35	+150	-35	+150	+150	+150	-35
2	-80	0*	0*	0*	-80	0*	-80	-80	-80	0*
3	0*	-80	-80	-80	0*	-80	0*	0*	0*	-80

\*SHOULD BE -40 WITH AM RECEIVE CONDITION ONLY

Test Point Location:

- J7, Pin 3 (Calibrator Socket)
- Junction of R-65 and C-153
- Junction of R-61 and C-64

oscilloscope while speaking into the microphone.

6. Set the FUNCTION switch to AM and repeat the above tests for PTT, VOX, and MOX operation.

7. While speaking into the microphone, in-

crease the MIC GAIN control from minimum and observe the introduction of sideband signal on the oscilloscope.

Place the FUNCTION switch in the CW position. Advance the VOX GAIN control full cw (maximum sensitivity). Speaking into the microphone in this condition should not result in transmit-receive switching.

Set the VOX-PTT switch to PTT and press the PTT button. The NCX-5 should not switch into transmit.

Press the MOX-OFF switch to MOX. The NCX-5 should switch to transmit. Return the MOX-OFF switch to OFF.

Insert a key into the key jack. A tap of the key should place the NCX-5 into a transmit condition. Upon release of the key, the unit should revert to receive in 1/10 of a second to one second, depending on the setting of the VOX DELAY control.

Hold the key closed, speak into the microphone and advance the MIC GAIN control. There should be no evidence of modulation on the oscilloscope.

Set the transmitting key for a long series of dots. Adjust the CARRIER INSERTION control for transmitter output just below full power. Observe the series of keying pulses on the high-frequency oscilloscope. A proper keying pulse should appear as in figure 6G. Figure 6H and 6I indicate improper keying sequences.

Set the FUNCTION switch to TUNE. Observe that full power output is attained on the oscilloscope. Adjust the CARRIER INSERTION control. There should be no change in the output signal.

Speak into the microphone and advance the MIC GAIN control. There should be no evidence of modulation on the oscilloscope.

Return the FUNCTION switch to SSB.

### 5.23 TRANSCEIVE VERNIER:

Set the NCX-5 to 3.700 Mc. Tune the accessory receiver to 9.72 Mc and lightly couple to the NCX-5 VFO. Observe that the beat note may be varied more than  $\pm 5$  Kc with the TRANSCEIVE VERNIER. Press the MOX-OFF switch to MOX. Observe that

the beat note does not change. Turn the TRANSCEIVE VERNIER OFF and observe that the beat note does not change. Return the NCX-5 to receive.

Disconnect all test equipment.

### — CAUTION —

IN THE FOLLOWING SERIES OF TESTS, THERE IS NO LOAD ON THE TRANSMITTER OUTPUT. IF THE UNIT SHOULD GO INTO TRANSMIT UNDER THIS CONDITION, SERIOUS DAMAGE CAN BE DONE TO THE FINAL OUTPUT STAGE. ALSO DURING THIS SERIES OF TESTS, A SIGNAL GENERATOR WILL BE CONNECTED TO THE ANTENNA TERMINALS. SERIOUS DAMAGE CAN BE DONE TO THIS SIGNAL GENERATOR IF THE UNIT IS ACCIDENTALLY PLACED INTO TRANSMIT.

### 5.24 ANTI-VOX CHECK:

Connect the signal generator to the antenna terminals through a suitable dummy load to match the 50 ohm input impedance. Set the signal generator for 4.0 Mc, the BAND switch to 3.5 Mc, and the main tuning dial to 4.0 Mc until a beat note is obtained at a frequency of approximately 1000 cycles. Connect the power output meter to the audio output terminals by use of the phone jack. Set the AUDIO GAIN control for approximately 1/2 watt. Measure the D.C. voltage at the junction of D3, R103, R107, and C157. A voltage of more than +10 volts should be indicated at this test point.

### 5.25 VFO JACK:

Connect 100 ohms from the VFO jack to ground. The beat note should disappear, indicating that the VFO is not functioning. Feed an external signal into the VFO jack between 9.52 and 10.02 Mc. It should be possible to retune the beat note with the external signal. Remove the external signal and the 100 ohm resistor. The original beat note should reappear.

TOP VIEW

FIGURE 4

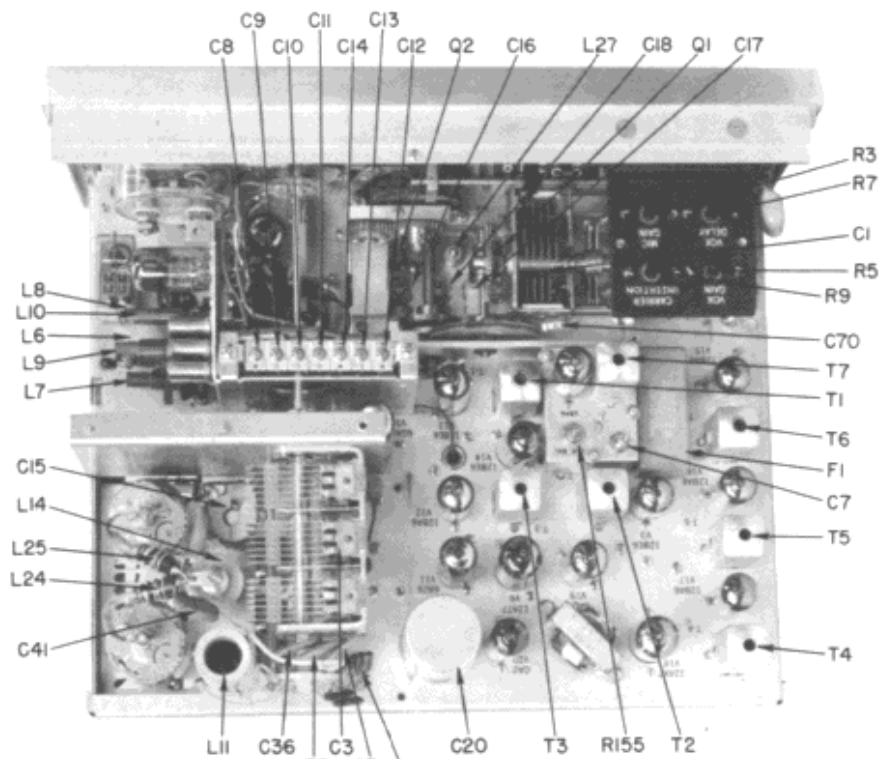

BOTTOM VIEW

FIGURE 5

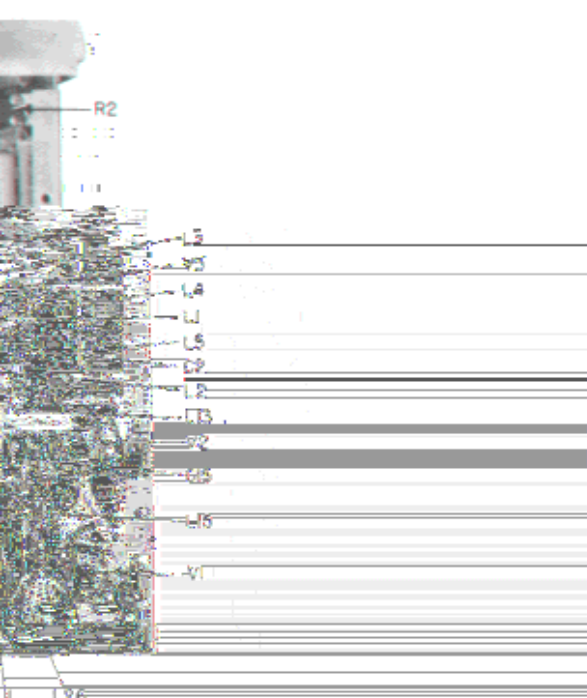
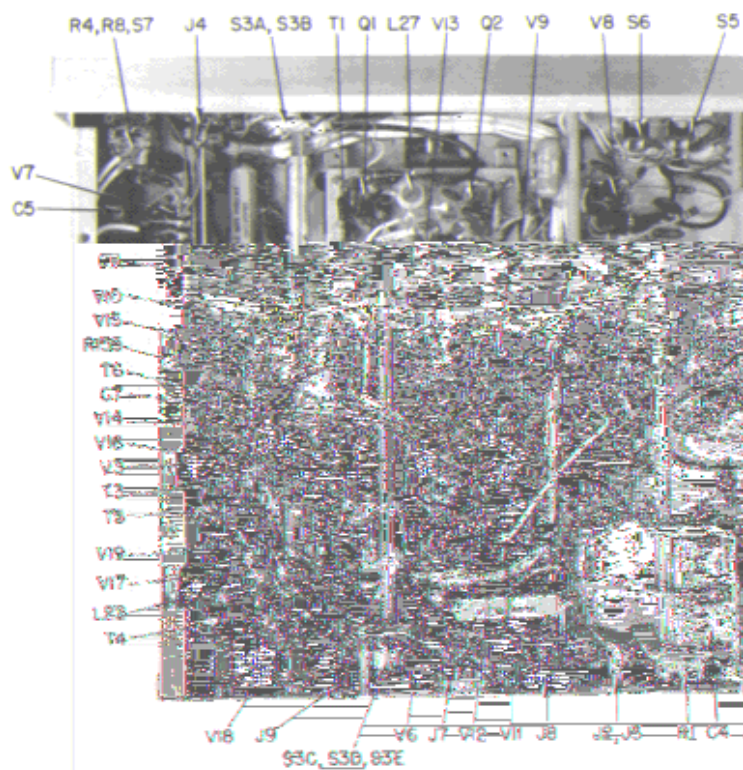

# NCX-5 WAVE FORMS

FIGURE 6

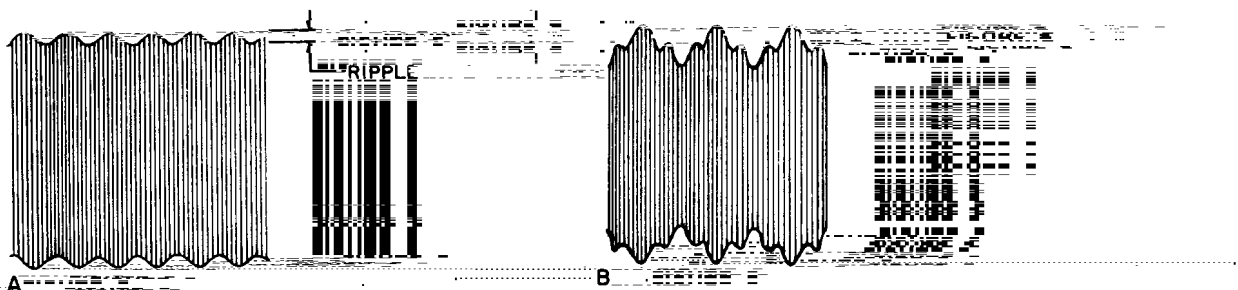

A

B

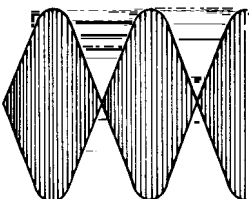

C (CORRECT)

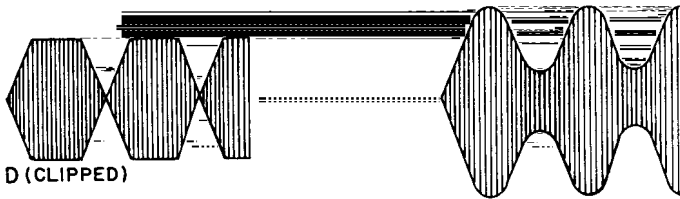

D (CLIPPED)

E (POOR CUSPS)

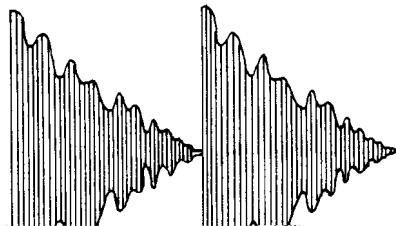

F



G

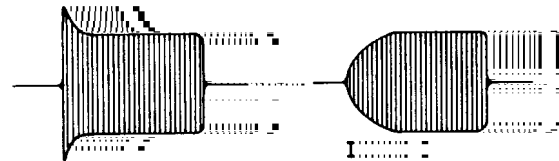

H

I





## SECTION 7 VOLTAGE AND RESISTANCE MEASUREMENTS

THE FOLLOWING DC VOLTAGE MEASUREMENTS ARE TAKEN WITH A VTVM WITH AN INPUT RESISTANCE GREATER THAN 10 MEGOHMS. RECEIVE VOLTAGES ARE TAKEN AT MAXIMUM RF GAIN WITH NO SIGNAL INPUT. FOR ANSWEER TO QUESTIONS REFER TO THE APPROPRIATE SECTION OF THE SERVICE MANUAL.

Function	Pin	Resistance	Voltage		Tube	Type
			Receive	Transmit		
FINAL AMPLIFIER	1	10k	0	-250	V-1	6Y6
	2	20k	0	0		
	3	50k	0	0		
	4	10k	12.6*	12.6*		
	5	20k	6.3*	6.3*		
	6	20k	-45 to -65 V ADJUSTABLE WITH BIAS CONTROL	0		
	7	10k	0	250		
	8	0	0	0		
	9	0	0	0		
FINAL AMPLIFIER	1	10k	0	270	V-2	6Y6
	2	20k	0	0		
	3	20k	0	0		
	4	20k	6.3*	6.3*		
	5	20k	0	0		
	6	20k	-45 to -65 V ADJUSTABLE WITH BIAS CONTROL	0		
	7	10k	0	270		
	8	0	0	0		
	9	0	0	0		
FIRST TRANSMITTER MIXER	1	100k	0	0	V-3	12BE6
	2	0	0	0		
	3	0	0	0		
	4	0	12.6*	12.6*		
	5	0	240	270		
	6	30k	240	240		
	7	0	0	0		
	8	0	0	0		
	9	0	0	0		
LOCAL OSCILLATOR AND SECOND TRANSMITTER MIXER	1	0	0	0	V-4	6K6
	2	0	0	0		
	3	0	0	0		
	4	0	0	0		
	5	0	0	0		
	6	0	0	0		
	7	0	0	0		
	8	0	0	0		
	9	0	0	0		
DRIVER	1	0	0	0	V-5	6G6
	2	0	0	0		
	3	0	0	0		
	4	0	0	0		
	5	0	0	0		
	6	0	0	0		
	7	0	0	0		
	8	0	0	0		
	9	0	0	0		
SPEECH AMPLIFIER	1	0	0	0	V-6	12AT6
	2	0	0	0		
	3	0	0	0		
	4	0	0	0		
	5	0	0	0		
	6	0	0	0		
	7	0	0	0		
	8	0	0	0		
	9	0	0	0		

\*AC OR DC DEPENDING ON SUPPLY





# NOX-A POWER SUPPLY

The NOX-A Power Supply is a conservatively rated

center tap of the high-voltage winding. The lo

... voltage ...  
 ... from the center tap ...  
 ... capacitor ...  
 ... resistor ...  
 ... terminal ...  
 ... connected directly to the transceiver ...  
 ... connections required

... provides 200 volts ...  
 ... Resistor R-1 ... 30,000 ohm ...  
 ... resistor to prevent shock hazard

... capable of providing all the necessary power ...  
 ... National ...  
 ... included with this supply

The output of the bias winding of the

diodes D5 and D6. This rectified output is filtered ...  
 and provides 80 volts at approximately 10 ma for ...  
 bias purposes as shown in the power supply

## CAUTION

... POWER SUPPLY ...  
 ... TRANSCEIVER WITHOUT ...  
 ... THIS SUPPLY IS USED ...  
 ... TRANSCEIVER IT WILL BE ...  
 ... REMOVE RESISTOR R-2 ...  
 ... WATTS

## NOX-A SUPPLY RATINGS

### INPUTS

115v AC 50/60 Hz 10/15/20/30/40/50/60 Watts

150 Watts receiver  
 365 Watts CW transmitter

### OUTPUTS

High Voltage: 700 VDC at 50 to 300 ma  
 Low Voltage: 280 VDC at 200 ma  
 Bias Voltage: 80 VDC at 10 ma

### DIMENSIONS

### WEIGHT

24 1/2 pounds

CAPACITORS ARE OBTAINED FROM THE FOLLOWING ...  
 LISTED ON THE SCHEMATIC

## LIST

Switch Transformer	B2762
Resistor 2500 ohms	A5082
Resistor 3000 ohms	A5083
Resistor 3300 ohms	A5084
Resistor 3600 ohms	A5085
Resistor 4000 ohms	A5086
Resistor 4500 ohms	A5087
Resistor 5000 ohms	A5088
Resistor 5600 ohms	A5089
Resistor 6000 ohms	A5090
Resistor 6600 ohms	A5091
Resistor 7500 ohms	A5092
Resistor 8200 ohms	A5093
Resistor 9000 ohms	A5094
Resistor 10000 ohms	A5095
Resistor 12000 ohms	A5096
Resistor 15000 ohms	A5097
Resistor 18000 ohms	A5098
Resistor 20000 ohms	A5099
Resistor 22000 ohms	A5100
Resistor 24000 ohms	A5101
Resistor 27000 ohms	A5102
Resistor 30000 ohms	A5103
Resistor 33000 ohms	A5104
Resistor 36000 ohms	A5105
Resistor 40000 ohms	A5106
Resistor 45000 ohms	A5107
Resistor 50000 ohms	A5108
Resistor 56000 ohms	A5109
Resistor 60000 ohms	A5110
Resistor 66000 ohms	A5111
Resistor 75000 ohms	A5112
Resistor 82000 ohms	A5113
Resistor 90000 ohms	A5114
Resistor 100000 ohms	A5115
Resistor 120000 ohms	A5116
Resistor 150000 ohms	A5117
Resistor 180000 ohms	A5118
Resistor 200000 ohms	A5119
Resistor 220000 ohms	A5120
Resistor 240000 ohms	A5121
Resistor 270000 ohms	A5122
Resistor 300000 ohms	A5123
Resistor 330000 ohms	A5124
Resistor 360000 ohms	A5125
Resistor 400000 ohms	A5126
Resistor 450000 ohms	A5127
Resistor 500000 ohms	A5128
Resistor 560000 ohms	A5129
Resistor 600000 ohms	A5130
Resistor 660000 ohms	A5131
Resistor 750000 ohms	A5132
Resistor 820000 ohms	A5133
Resistor 900000 ohms	A5134
Resistor 1000000 ohms	A5135
Resistor 1200000 ohms	A5136
Resistor 1500000 ohms	A5137
Resistor 1800000 ohms	A5138
Resistor 2000000 ohms	A5139
Resistor 2200000 ohms	A5140
Resistor 2400000 ohms	A5141
Resistor 2700000 ohms	A5142
Resistor 3000000 ohms	A5143
Resistor 3300000 ohms	A5144
Resistor 3600000 ohms	A5145
Resistor 4000000 ohms	A5146
Resistor 4500000 ohms	A5147
Resistor 5000000 ohms	A5148
Resistor 5600000 ohms	A5149
Resistor 6000000 ohms	A5150
Resistor 6600000 ohms	A5151
Resistor 7500000 ohms	A5152
Resistor 8200000 ohms	A5153
Resistor 9000000 ohms	A5154
Resistor 10000000 ohms	A5155
Resistor 12000000 ohms	A5156
Resistor 15000000 ohms	A5157
Resistor 18000000 ohms	A5158
Resistor 20000000 ohms	A5159
Resistor 22000000 ohms	A5160
Resistor 24000000 ohms	A5161
Resistor 27000000 ohms	A5162
Resistor 30000000 ohms	A5163
Resistor 33000000 ohms	A5164
Resistor 36000000 ohms	A5165
Resistor 40000000 ohms	A5166
Resistor 45000000 ohms	A5167
Resistor 50000000 ohms	A5168
Resistor 56000000 ohms	A5169
Resistor 60000000 ohms	A5170
Resistor 66000000 ohms	A5171
Resistor 75000000 ohms	A5172
Resistor 82000000 ohms	A5173
Resistor 90000000 ohms	A5174
Resistor 100000000 ohms	A5175
Resistor 120000000 ohms	A5176
Resistor 150000000 ohms	A5177
Resistor 180000000 ohms	A5178
Resistor 200000000 ohms	A5179
Resistor 220000000 ohms	A5180
Resistor 240000000 ohms	A5181
Resistor 270000000 ohms	A5182
Resistor 300000000 ohms	A5183
Resistor 330000000 ohms	A5184
Resistor 360000000 ohms	A5185
Resistor 400000000 ohms	A5186
Resistor 450000000 ohms	A5187
Resistor 500000000 ohms	A5188
Resistor 560000000 ohms	A5189
Resistor 600000000 ohms	A5190
Resistor 660000000 ohms	A5191
Resistor 750000000 ohms	A5192
Resistor 820000000 ohms	A5193
Resistor 900000000 ohms	A5194
Resistor 1000000000 ohms	A5195
Resistor 1200000000 ohms	A5196
Resistor 1500000000 ohms	A5197
Resistor 1800000000 ohms	A5198
Resistor 2000000000 ohms	A5199
Resistor 2200000000 ohms	A5200
Resistor 2400000000 ohms	A5201
Resistor 2700000000 ohms	A5202
Resistor 3000000000 ohms	A5203
Resistor 3300000000 ohms	A5204
Resistor 3600000000 ohms	A5205
Resistor 4000000000 ohms	A5206
Resistor 4500000000 ohms	A5207
Resistor 5000000000 ohms	A5208
Resistor 5600000000 ohms	A5209
Resistor 6000000000 ohms	A5210
Resistor 6600000000 ohms	A5211
Resistor 7500000000 ohms	A5212
Resistor 8200000000 ohms	A5213
Resistor 9000000000 ohms	A5214
Resistor 10000000000 ohms	A5215
Resistor 12000000000 ohms	A5216
Resistor 15000000000 ohms	A5217
Resistor 18000000000 ohms	A5218
Resistor 20000000000 ohms	A5219
Resistor 22000000000 ohms	A5220
Resistor 24000000000 ohms	A5221
Resistor 27000000000 ohms	A5222
Resistor 30000000000 ohms	A5223
Resistor 33000000000 ohms	A5224
Resistor 36000000000 ohms	A5225
Resistor 40000000000 ohms	A5226
Resistor 45000000000 ohms	A5227
Resistor 50000000000 ohms	A5228
Resistor 56000000000 ohms	A5229
Resistor 60000000000 ohms	A5230
Resistor 66000000000 ohms	A5231
Resistor 75000000000 ohms	A5232
Resistor 82000000000 ohms	A5233
Resistor 90000000000 ohms	A5234
Resistor 100000000000 ohms	A5235
Resistor 120000000000 ohms	A5236
Resistor 150000000000 ohms	A5237
Resistor 180000000000 ohms	A5238
Resistor 200000000000 ohms	A5239
Resistor 220000000000 ohms	A5240
Resistor 240000000000 ohms	A5241
Resistor 270000000000 ohms	A5242
Resistor 300000000000 ohms	A5243
Resistor 330000000000 ohms	A5244
Resistor 360000000000 ohms	A5245
Resistor 400000000000 ohms	A5246
Resistor 450000000000 ohms	A5247
Resistor 500000000000 ohms	A5248
Resistor 560000000000 ohms	A5249
Resistor 600000000000 ohms	A5250
Resistor 660000000000 ohms	A5251
Resistor 750000000000 ohms	A5252
Resistor 820000000000 ohms	A5253
Resistor 900000000000 ohms	A5254
Resistor 1000000000000 ohms	A5255
Resistor 1200000000000 ohms	A5256
Resistor 1500000000000 ohms	A5257
Resistor 1800000000000 ohms	A5258
Resistor 2000000000000 ohms	A5259
Resistor 2200000000000 ohms	A5260
Resistor 2400000000000 ohms	A5261
Resistor 2700000000000 ohms	A5262
Resistor 3000000000000 ohms	A5263
Resistor 3300000000000 ohms	A5264
Resistor 3600000000000 ohms	A5265
Resistor 4000000000000 ohms	A5266
Resistor 4500000000000 ohms	A5267
Resistor 5000000000000 ohms	A5268
Resistor 5600000000000 ohms	A5269
Resistor 6000000000000 ohms	A5270
Resistor 6600000000000 ohms	A5271
Resistor 7500000000000 ohms	A5272
Resistor 8200000000000 ohms	A5273
Resistor 9000000000000 ohms	A5274
Resistor 10000000000000 ohms	A5275
Resistor 12000000000000 ohms	A5276
Resistor 15000000000000 ohms	A5277
Resistor 18000000000000 ohms	A5278
Resistor 20000000000000 ohms	A5279
Resistor 22000000000000 ohms	A5280
Resistor 24000000000000 ohms	A5281
Resistor 27000000000000 ohms	A5282
Resistor 30000000000000 ohms	A5283
Resistor 33000000000000 ohms	A5284
Resistor 36000000000000 ohms	A5285
Resistor 40000000000000 ohms	A5286
Resistor 45000000000000 ohms	A5287
Resistor 50000000000000 ohms	A5288
Resistor 56000000000000 ohms	A5289
Resistor 60000000000000 ohms	A5290
Resistor 66000000000000 ohms	A5291
Resistor 75000000000000 ohms	A5292
Resistor 82000000000000 ohms	A5293
Resistor 90000000000000 ohms	A5294
Resistor 100000000000000 ohms	A5295
Resistor 120000000000000 ohms	A5296
Resistor 150000000000000 ohms	A5297
Resistor 180000000000000 ohms	A5298
Resistor 200000000000000 ohms	A5299
Resistor 220000000000000 ohms	A5300
Resistor 240000000000000 ohms	A5301
Resistor 270000000000000 ohms	A5302
Resistor 300000000000000 ohms	A5303
Resistor 330000000000000 ohms	A5304
Resistor 360000000000000 ohms	A5305
Resistor 400000000000000 ohms	A5306
Resistor 450000000000000 ohms	A5307
Resistor 500000000000000 ohms	A5308
Resistor 560000000000000 ohms	A5309
Resistor 600000000000000 ohms	A5310
Resistor 660000000000000 ohms	A5311
Resistor 750000000000000 ohms	A5312
Resistor 820000000000000 ohms	A5313
Resistor 900000000000000 ohms	A5314
Resistor 1000000000000000 ohms	A5315
Resistor 1200000000000000 ohms	A5316
Resistor 1500000000000000 ohms	A5317
Resistor 1800000000000000 ohms	A5318
Resistor 2000000000000000 ohms	A5319
Resistor 2200000000000000 ohms	A5320
Resistor 2400000000000000 ohms	A5321
Resistor 2700000000000000 ohms	A5322
Resistor 3000000000000000 ohms	A5323
Resistor 3300000000000000 ohms	A5324
Resistor 3600000000000000 ohms	A5325
Resistor 4000000000000000 ohms	A5326
Resistor 4500000000000000 ohms	A5327
Resistor 5000000000000000 ohms	A5328
Resistor 5600000000000000 ohms	A5329
Resistor 6000000000000000 ohms	A5330
Resistor 6600000000000000 ohms	A5331
Resistor 7500000000000000 ohms	A5332
Resistor 8200000000000000 ohms	A5333
Resistor 9000000000000000 ohms	A5334
Resistor 10000000000000000 ohms	A5335
Resistor 12000000000000000 ohms	A5336
Resistor 15000000000000000 ohms	A5337
Resistor 18000000000000000 ohms	A5338
Resistor 20000000000000000 ohms	A5339
Resistor 22000000000000000 ohms	A5340
Resistor 24000000000000000 ohms	A5341
Resistor 27000000000000000 ohms	A5342
Resistor 30000000000000000 ohms	A5343
Resistor 33000000000000000 ohms	A5344
Resistor 36000000000000000 ohms	A5345
Resistor 40000000000000000 ohms	A5346
Resistor 45000000000000000 ohms	A5347
Resistor 50000000000000000 ohms	A5348
Resistor 56000000000000000 ohms	A5349
Resistor 60000000000000000 ohms	A5350
Resistor 66000000000000000 ohms	A5351
Resistor 75000000000000000 ohms	A5352
Resistor 82000000000000000 ohms	A5353
Resistor 90000000000000000 ohms	A5354
Resistor 100000000000000000 ohms	A5355
Resistor 120000000000000000 ohms	A5356
Resistor 150000000000000000 ohms	A5357
Resistor 180000000000000000 ohms	A5358
Resistor 200000000000000000 ohms	A5359
Resistor 220000000000000000 ohms	A5360
Resistor 240000000000000000 ohms	A5361
Resistor 270000000000000000 ohms	A5362
Resistor 300000000000000000 ohms	A5363
Resistor 330000000000000000 ohms	A5364
Resistor 360000000000000000 ohms	A5365
Resistor 400000000000000000 ohms	A53

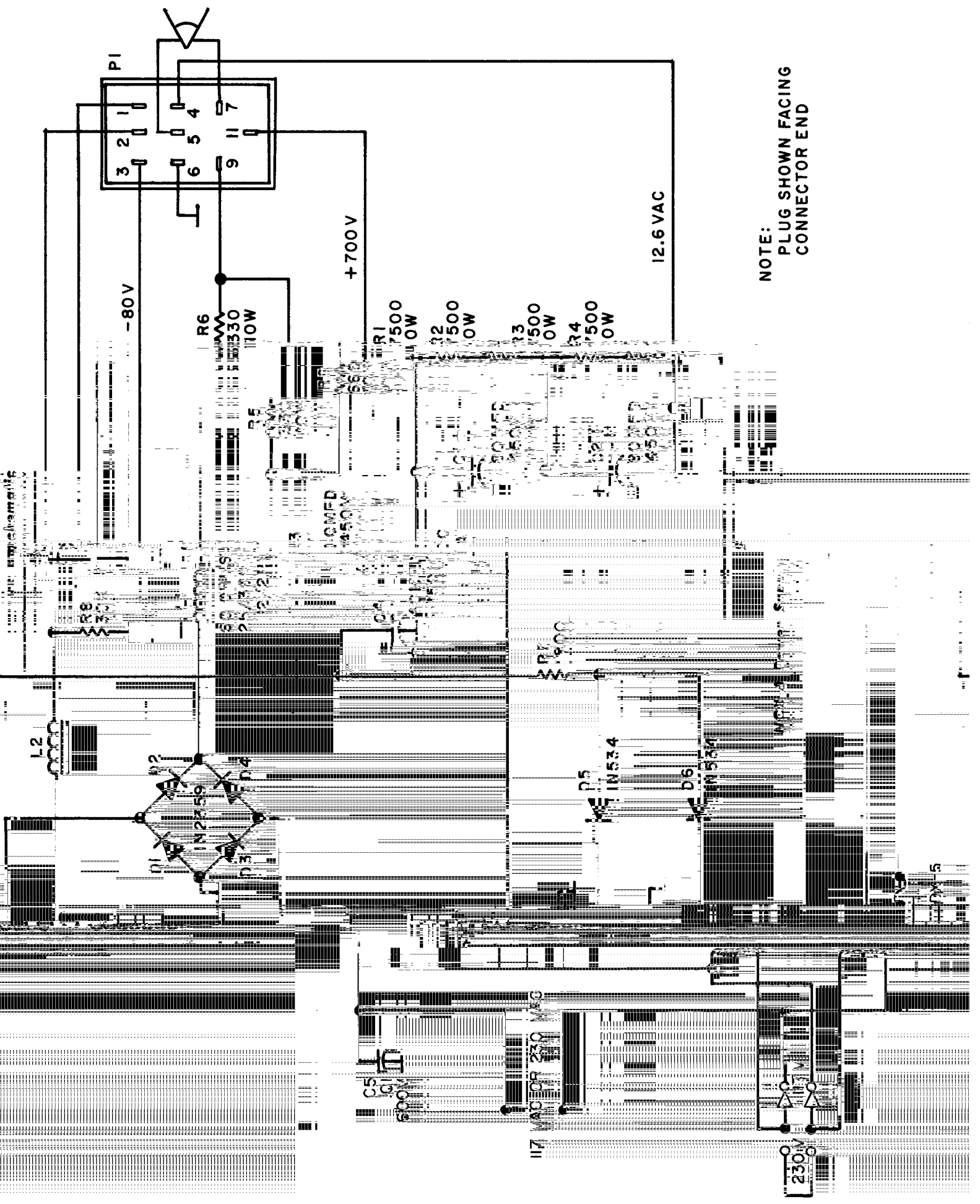

NOTE:  
PLUG SHOWN FACING  
CONNECTOR END

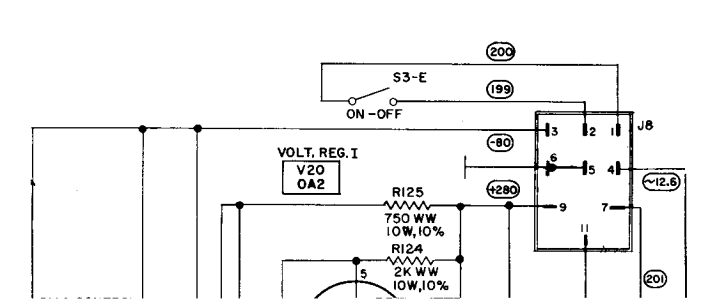
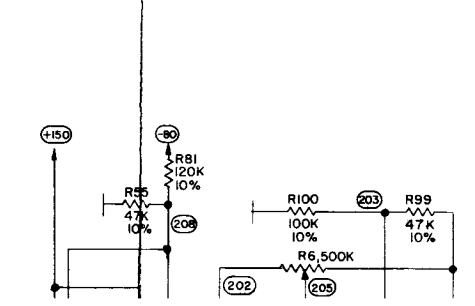
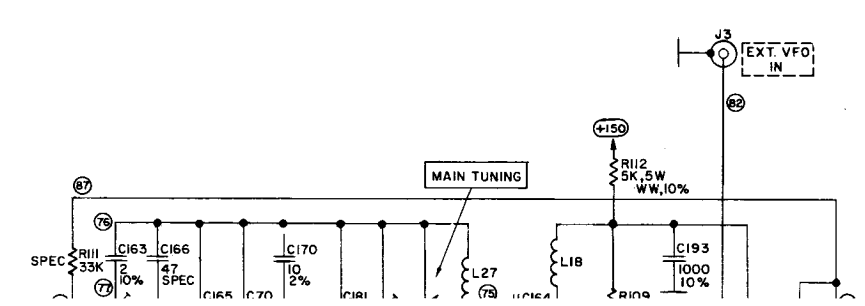
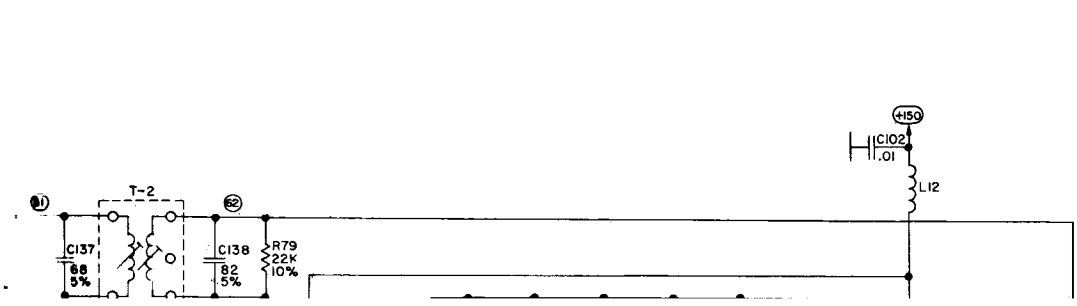

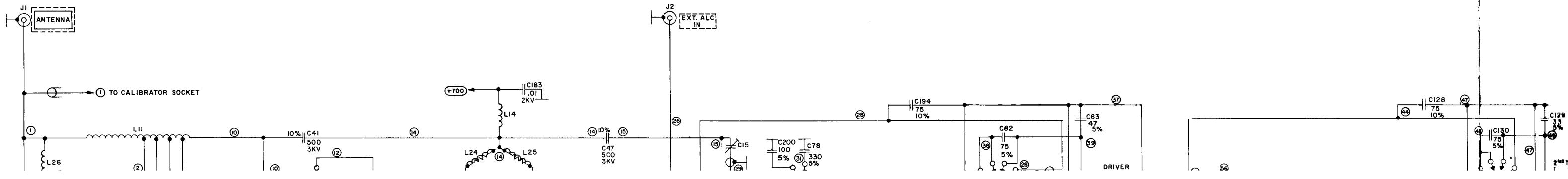

2ND TM  
1.1.2.2

