

**HQ-180
SERIES
COMMUNICATIONS
RECEIVERS**

**TECHNICAL
DESCRIPTION
AND
OPERATING
INSTRUCTIONS**

HAMMARLUND

Hammarlund Manufacturing Company, Inc.
A Giannini Scientific Co.
53 West 23rd Street, New York 10, N. Y.
Export Department: 13 East 40th Street, New York 16, N. Y.

52787-1

THE HAMMARLUND 180 AND 180-A SERIES OF
COMMUNICATIONS RECEIVERS

CONTENTS OF INSTRUCTION AND SERVICE MANUAL

Specifications	Page 3
Circuit Description	Page 6
Installation	Page 8
Operation	Page 17
Service and Maintenance	Page 24
Removing and Replacing The Chassis	Page 35
Removing and Replacing The Front Panel	Page 37
Alignment Procedure	Page 45
Tube Socket Voltages	Pages 58, 60, 62, 64
Tube Socket Resistances	Pages 59, 61, 63, 65
Parts List	Page 66
Schematic Diagram	Page 76

HQ-180 AND 180-"A" SERIES SPECIFICATIONS

Frequency Range Covered:
 .54-1.05mc/s; 1.05-2.05 mc/s; 2.05-4.04
 mc/s; 4.0-7.85 mc/s; 7.85-15.35 mc/s;
 15.35-30.0 mc/s.

Bandspread Calibration:
 Dial markings every 5 kc/s on 15, 20, 40
 and 80 meter bands; every 10 kc/s on 10
 meter band; plus arbitrary 0-100 logging
 scale.

Maximum Audio Output:
 1.0 Watt (Undistorted)

Beat Frequency Oscillator:
 Variable from zero beat plus/minus 2 kcs
 plus fixed position for SSB.

Slot Filter:
 Range plus/minus 5 kcs of center frequency.
 Attenuation over plus/minus 5 kcs range
 provides over 40 db. Calibrations every
 1 kc. Maximum attenuation using slot
 depth control is 60 db. 8:1 vernier tuning
 ratio.

Tube Complement:
 6BZ6 RF Amplifier
 6AV6 1st AF Amp.

AVC Action:
 Operates on RF and 3 1F stages. Provides
 fast charge--adjustable discharge smooth
 acting AVC. Delayed AVC applied to the RF
 stage. Better than .001 second attack time
 and .01 - .1-1 second decay time. Off
 position.

Adjustable Selectivity and Selectable Side-
 bands:
 6 db bandwidths Upper sideband--1-2-3 kcs
 Lower sideband--1-2-3 kcs Both sidebands--
 .5-2-4-6 kcs

Sensitivity:
 An average of 1.5 microvolts produces 10:1
 signal-to-noise ratio on AM approximately
 .7 uv on CW and SSB.

Antenna Input:
 50 to 600 ohms; balanced or unbalanced.

6BA6 60 kc 1F Amp.
 6BV8 60 kc 1F amp. AVC-AM Det.
 12AU7 SSB Product Detector
 6AL5 Noise Limiter
 12AU7 BFO-"S" Meter Amplifier
 6AV6 1st A F Amp. - Delayed AVC
 Clamp
 6AQ5 Audio Power Output
 OA2 Voltage Regulator
 6BZ6 Crystal Calibrator
 6CW4 Crystal Oscillator

Semiconductor Complement:
 Rectifier -- Two 800 P.I.V. at 1/2 amp.

Power Supply:
 105-125 Volts 50-60 cps. a.c. power con-
 sumption. 120 watts.

"S" Meter:
 Calibrated 1 to 9 in steps approximately
 6 db. Also includes db scale, above 5-9
 to plus 40 db. (Meter deflects on all types

Front Panel Equipment:

Main Tuning
Bandspread Tuning
Vernier or Bandpass Tuning
Sensitivity (dB Gain):
on/off switch
Selectivity: 0.5-1-2-3 Kcs.
(per sideband)
Sideband: Upper-lower-both
Audio Gain
Antenna Compensator
Tuning Range (Band Selector)
Function Switch: AM-SSB-CW
Slot req. Calib.
CW Tone (BFO Pitch)
Noise Limiter, adjustable
-on/off switch
AVC, off-slow-medium-fast
Send-Receive-Calibrate
Phone Jack
"S" Meter
Dial Scale reset

Rear Panel Equipment:

Terminals for speaker connections
3.2 ohm for voice coil
500 ohm for line or VOX

Accessory socket for preamp, Q-multiplier or converter. System socket for simplified associated transmitter/receiver control.

S-meter controls.

Antenna input terminal - via 30239.

Dimensions:

10-1/2" H x 19" W x 13" D
Wt. 38 lbs.
Shipping Wt. 45 lbs.

HQ-180AX

Universal model of the HQ-180A receiver with provisions for 11 fixed-frequency crystal controlled channels. Six of the crystals are easily interchangeable from the front panel--the balance are located within the cabinet but are readily accessible from the trap-door top. 3 kc vernier tuning control permits compensation for minor frequency variations of the crystals.

24 HOUR CLOCK-TIMER

Combination clock and automatic timer. Aids in meeting prearranged schedules. Optional extra.

I AMPLIFIER The 3035 KCS and 455 KCS IF amplifiers provide eight tuned circuits in three stages of amplification. Six tuned circuits in the three-stage 60 KCS amplifier provide either the second or third conversion, depending upon the operating band. All I circuits employ iron-core permeability-tuned transformers for the high performance and retention of alignment accuracy. The 60 KCS amplifier selectivity is controlled from the front panel by seven positions: 1-2-3 KCS on either sideband, and .5-2-4-6 KCS on both sidebands. The skirt selectivity of this system approaches that of the mechanical filter. A separate front panel switch is used to select upper, lower, or both sidebands, providing rapid, simple means of sideband selection.

SLOT FILTER The slot filter provides a notch of better than 60 db attenuation over the entire range of ± 5 KCS from the center IF (455 KCS) frequency. The slot filter control provides 40 db attenuation, plus an additional attenuation of up to 20 db obtainable by use of the slot depth control at a particular frequency.

SEPARATE VERNIER TUNING ± 3 KCS vernier tuning allows extra-fine passband tuning between the 455 KCS IF and the 60 KCS IF for additional selectivity and easy tuning of the desired signal.

AVC An extremely fast-attack delayed AVC circuit is employed. A four position control on the front panel permits the selection of OFF-AVC or SLOW-MEDIUM-FAST AVC decay time for optimum results on various signals. The AVC is taken from the high selectivity 60 KCS IF.

S-METER Readings of signal strength and "on-the-point" tuning indications are provided on all types of signals by a high-response S meter circuit. The scale is calibrated to 40 db over S-9 and is factory-calibrated so a signal of approximately 50 microvolts reads S-9. Each S-unit indicates approximately a 6 db increase, equivalent to doubling the signal strength. S-meter is extremely effective on SSB and CW when using slow decay AVC.

AUDIO The HQ-180A features the exclusive Hammarlund Auto-Response which automatically adjusts the audio passband to best meet the receiving conditions. A 6AQ5 provides 1.0 watt for maximum undistorted output. The Auto-Response circuit employs controlled feedback which is decreased as the gain control is turned up, thus narrowing the audio passband. As the gain is decreased, the feedback increases, thus permitting a greater frequency response in the audio output. The

either earphones or loudspeaker. The phone plug automatically silences the speaker upon insertion. The Audio-Response permits tops in listening pleasure of AM, SSB, and CW reception.

HQ-180A DESCRIPTION

Starting with the front panel layout, the careful selection of high-reliability components, the craftsmanship of skilled technicians, and the addition of engineering leadership result in a receiver worthy of the Hammarlund name in quality and performance.

The HQ-180A offers the listener a practically endless combination of tuning techniques whereby reception of SSB/CW and AM/MCW may be achieved. Through the use of the vernier tuning, adjustable bandwidth, and the basic, precision front-end of the HQ-180A the user has full control over SSB signals as well as adjacent, or co-channel signals. If there's a signal to be received, the HQ-180A can ferret it out...

The HQ-180A is a "hot" receiver. It will provide 10 db signal-to-noise ratio at 1.5 uvolt AM or approximately .5 uvolt CW, or better depending on bandwidth. The front end provides continuous tuning .54 mc/s to 30 mc/s. The receiver is designed for use with a single wire flat top, a folded dipole, or doublet antenna.

CIRCUITRY The HQ-180 is an eighteen tube triple conversion superheterodyne receiver (double conversion, .54 to 7.85 megacycles) that has been designed to provide the best possible performance for reception of AM, SSB and CW signals. The most important performance characteristics of a communications receiver have been made adjustable by means of the front panel knobs.

The RF tuning system covers the following bands:

MAIN TUNING DIAL

.54 to	1.05 mc...	cal in	10 kc divs.
1.05 to	2.05 mc...	cal in	10 kc divs.
2.05 to	4.04 mc...	cal in	20 kc divs.
4.0 to	7.85 mc...	cal in	50 kc divs.
7.85 to	15.35 mc...	cal in	100 kc divs.
15.35 to	30.0 mc...	cal in	100 kc divs.

BAND SPREAD TUNING DIAL

Arbitrary scale	0 to 100 divs.
3.44 to	4.040 mc...	cal in 5 kc divs.
6.810 to	7.3 mc...	cal in 5 kc divs.
13.980 to	14.425 mc...	cal in 5 kc divs.
20.925 to	21.60 mc...	cal in 5 kc divs.
27.890 to	29.7 mc...	cal in 10 kc divs.

A built-in 100 kcs crystal calibrator provides marker signals at every 100 kcs on all bands for checking dial calibration accuracy.

The dial calibration reset knob enables you to adjust the frequency calibration to approach frequency meter standards on each amateur band.

Starting at the front-end, the HQ-180A utilizes a (6BZ6) tuned RF amplifier and a separate mixer (6BE6) and oscillator (6C4) for a high degree of stability. Advanced design and modern tube types account for the very high gain and low noise factor. Refer to page one for complete listing of the many possible functions and the complete tube lineup.

Low-loss, coil forms, and bandswitch wafers, plus temperature-compensating capacitors, and the application of regulated power to the oscillator circuit provide a high degree of stability.

TRIPLE CONVERSION The HQ-180A offers triple conversion with IF frequencies of 3035 KCS, 455 KCS, and 60 KCS, providing excellent rejection of image-response. The second IF is heterodyned with a crystal-controlled oscillator. The third IF is heterodyned with a high stability, adjustable oscillator which contains micro-accurate vernier tuning control, located on the front panel.

The HQ-180A Series differs from the 180 Series in the following respects:

1. The power supply is designed for 115/230 v. 50, 60 cycle AC operation. This applies to the power transformer T-30 and the new filament transformer T22.
2. A separate filament transformer is employed, T-22 in the schematic diagram. This transformer provides 24 hour a day operation of the heaters of the high frequency oscillator and first converter, to reduce initial warm up drift. In addition, this transformer also supplies the systems socket which is a new added feature. If the receiver is not to be operated for long periods (upwards of 3 days) the line cord should be removed from the socket.
3. A new accessory socket plus a systems socket has been added. The accessory socket may be used to power most 6 and 2 meter converters. The systems socket will be found convenient when the HQ-180AX series of receiver is employed in conjunction with a transmitter since all of the necessary VOX anti trip and/or relay connections are available from this socket. This also provides a rapid disconnect without the need of tools once the installation has been completed properly. A Coordination Cable is available for use with the HQ-180A or HQ-170A series of receivers designed primarily for use with the HX-50 Hammarlund transmitter but useable with other transmitters as well. This is part #PL39286-G1 at \$8.50.
4. A new three (3) position BFO switch is provided enabling the BFO to be in the off position, SSB, where the BFO is fixed for optimum SSB audio response with reference to the passband. The CW position enables the BFO to be adjusted plus or minus 2 KC thus providing the usual pitch control adjustment. For CW reception, the BFO should always be set plus or minus 500 cycles to 1000 cycles especially in the .5 KC selectivity position so as to prevent detuning of the desired signal for the desired pitch.
5. 3.2 ohms and 500 ohms output terminations are now provided for voice coil or line operation. The 500 ohm line termination will be found very advantageous for phone patch and improved anti trip operation of most VOX circuits.
6. The 5U4G tube formerly used in the HQ-180 has now been replaced with two (2) silicon diode rectifiers thus providing cooler operation and better regulation from the power supply.
7. The HQ-180AX series of receivers provides an 11 position fixed frequency crystal oscillator assembly which is factory installed in the panel space provided for the 24 hour clock timer. The knob on this assembly allows selection of normal variable frequency tuning or any one of eleven fixed frequencies crystal controlled. Six crystals are mounted on the front plate of the oscillator assembly and may be changed quite readily to shift frequency. The remaining

5 crystals are mounted behind the front panel on the oscillator box and may be changed by lifting the top cover of the cabinet. It is intended that the five inside crystals will be for commonly used channels not subject to being changed very often. The receiver can be zeroed into the channel frequency by manipulating the vernier tuning control on the front panel. This will correct for frequency discrepancy due to crystal tolerance and assure accurate "netting".

The use of the crystal controlled oscillator will permit the highly stable reception of signals on the eleven channels selected. The only operation required beside turning the selector switch to the desired crystal position is to turn the band switch to the required position and tune the main dial to the approximate frequency rocking the knob finally for maximum "S" meter indication.

In order to ensure proper operation the crystals should be ordered from your local authorized Hammarlund distributor.

The oscillator or actual crystal frequency for a given signal frequency shall be determined from the following:

<u>SIGNAL FREQUENCY</u> <u>RANGE mc</u>	<u>ADD IF -----</u> <u>FREQUENCY mc</u>	<u>SUBTRACT IF-</u> <u>FREQUENCY mc</u>	<u>MODE OF</u> <u>OPERATION</u>
.54 to 1.05 mc	.455000		Fundamental
1.05 to 2.05 mc	.455000		Fundamental
2.05 to 4. mc	.455000		Fundamental
4.0 to 7.85 mc	.455000		Fundamental
7.85 to 15.35 mc	3.035		Fundamental
15.35 to 20.662 mc	3.035		Fundamental
20.662 to 30.000 mc		3.035	2nd Harmonic

NOTE: WHERE LOW SIDE INJECTION IS SPECIFIED, HIGH SIDE INJECTION MAY BE USED AT REDUCED SENSITIVITY.

HQ-180A INSTALLATION

Your Hammarlund Receiver is designed to give you the very best results. A few minutes to be sure it is installed correctly is worth while. Even though we have developed the most sensitive circuitry to select and amplify the signal you want to hear, remember that it can work only on the Rf you feed it from your antenna. It is to obtain the most satisfaction in its operation that we urge you to put up the best antenna system you can. The HQ-180A will work very well with a temporary wire strung out of a window, but only use this method while constructing or having constructed a proper antenna system. Finally, a good ground, serves many purposes; one, it eliminates tendencies towards AC hum pickup, often straying through homes or apartments; two, it minimizes atmospheric and man-made noise; three, it ensures a safe path for any voltage coming from a possible short or from an associated transmitter. When using an outside antenna, it is always best to install a lightning arrestor. Such a device drains off the atmospheric charge in a safe manner, protecting you, and the Receiver.

Note that all of the Receiver connections are at the rear of the set, and that there are a variety of very useful terminal points, permitting a number of important system connections to be permanently attached in a neat manner. The illustrations below show you all of them, allowing you full freedom to use those that are most useful to you, whether you are only listening or are operating with a transmitter. The Accessory and System sockets, are all for special applications associated with reception, but not necessary for ordinary operation. The speaker and antenna connections are required in any case.

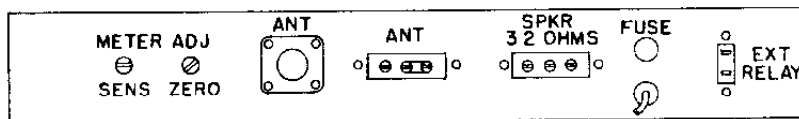

HQ-180 SERIES

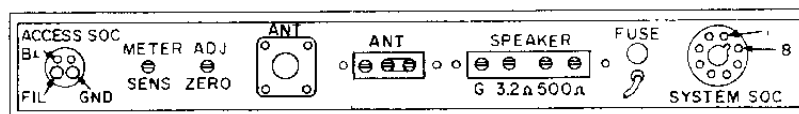

HQ-180A SERIES

RECEIVER REAR CONNECTIONS

Connect a suitable 3.2-ohm loudspeaker to the 3.2-ohm terminal screws as shown in the diagram. Use a Hammarlund 3-200 Speaker for best results, but any equivalent speaker in a cabinet will operate satisfactorily. Do not place the speaker cabinet on top of the Receiver, because the 5Q-180A is a very sensitive set, and speaker vibration can cause regenerative oscillation electronically, impairing reception. Note that a jack is provided in the lower left corner of the front of the Receiver for headphone plug insertion. The loudspeaker is automatically disconnected when the phone plug is inserted.

HEADPHONES

High impedance magnetic phones will usually be found satisfactory when the headphone jack is employed. The phones are deliberately mismatched to reduce the level into them. If more level or volume is desirable, low impedance phones may be employed. These may be any of the popular impedances such as 8, 16 or 24 ohms. If you do not have headphones and desire to purchase a pair, the low impedance type is suggested since it will always be possible to reduce the volume by making use of the audio volume control.

Another alternative, if high impedance phones are available, is to permanently connect these to the 500 ohm line output terminals on the rear of the receiver. These will provide more volume than the headphone jack since the headphone jack impedance is 3.2 ohms or the same as the speaker. ("A" Series only.)

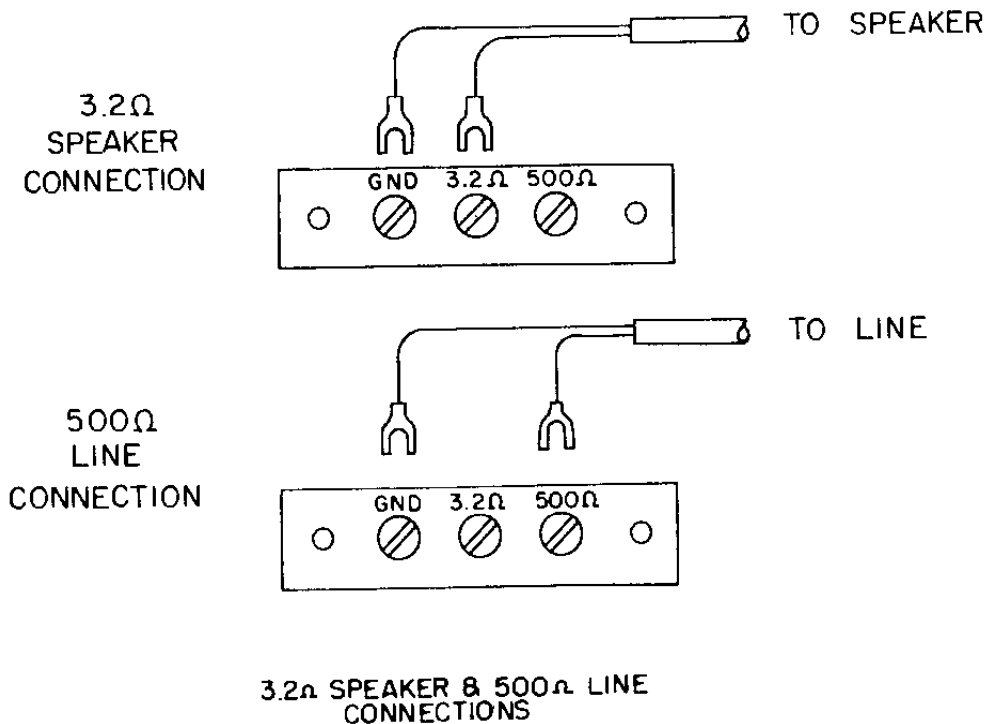

The Receiver connections for the antenna and ground are clearly illustrated on these pages, and a few hints are given for antenna installation, but the HQ-180A owner is urged to read a good antenna book to select the best type for his purpose. The Amateur Radio Relay League publishes this type of information. Its Antenna Book provides all you need to know about antennas for both reception and transmission. Other publishers produce equivalent books on this subject.

After selecting the antenna desired, consult the diagrams in this Manual to make the proper connections to the receiver. Following are some tips on antenna system selection and installation.

Either a single-wire or a balanced antenna may be used with the HQ-180A. The front panel antenna trimmer control is designed to permit a good match to almost all antenna systems of 50 to 600 ohms, balanced or unbalanced. The coaxial connector is intended to be used for 50-ohms types, the terminal strip for up to 300 ohms. While general coverage can be obtained from a short wire of 20 to 50 feet, much improved reception will be developed from an outdoor single-wire system of 50 to 150 feet in length. It is recommended that the antenna be isolated as much as possible from near-by objects, buildings, trees, etc., and that it be located at right angles to power lines or busy highways. This will minimize interference pickup from the lines or from passing vehicles.

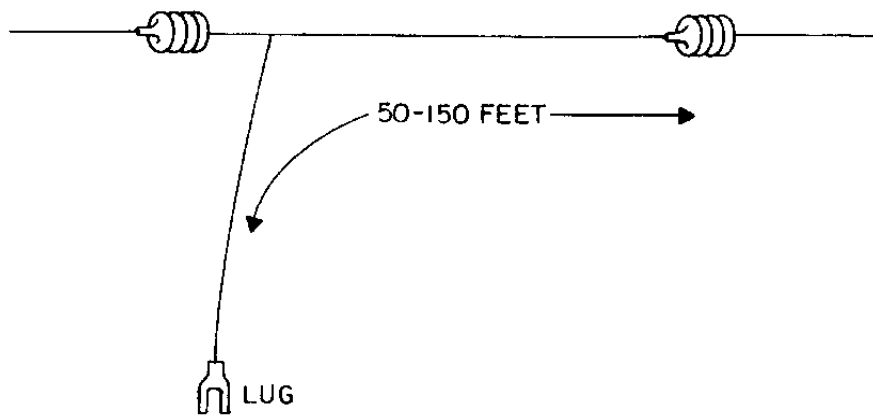

SINGLE WIRE ANTENNA

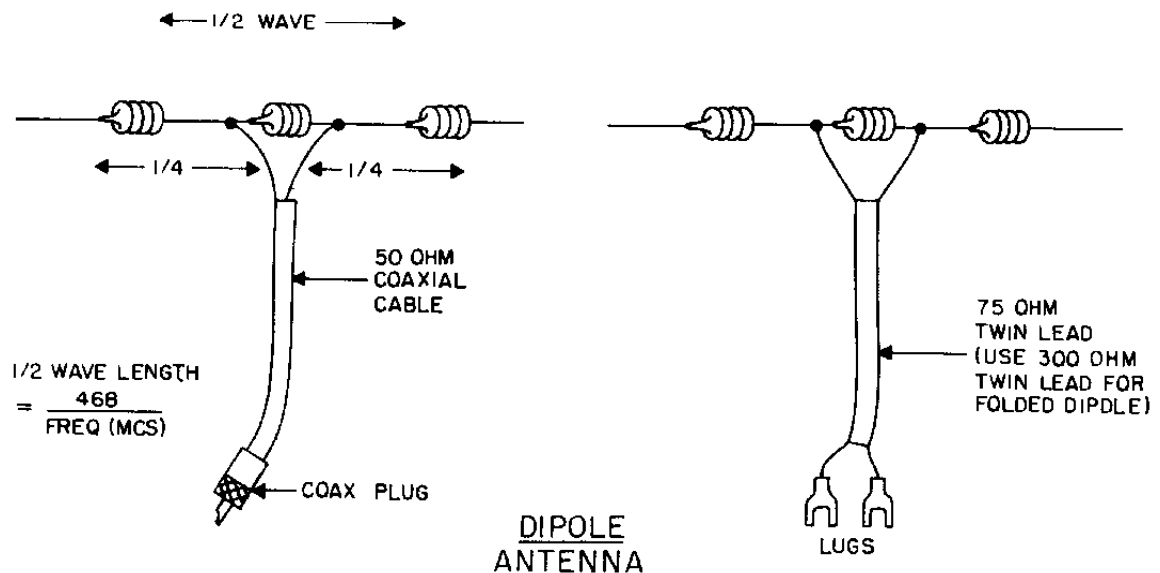

DIPOLE ANTENNA

The first antenna connection illustration shows the simplest system. This arrangement provides good overall coverage, but if a particular band is intended to be used consistently, the use of a dipole tuned to that band is recommended. The illustrations show how such an antenna is made and what Receiver connections are necessary. For all antennas, the shielded or twin-lead methods are a decided improvement over the single wire to minimize man-made interference and noise signals. In especially noisy areas, this may be the only way to develop an acceptable signal.

Each of the antenna connection schemes require very little wiring complications or soldering technique. For those familiar with soldering, no trouble will appear. For those who have never soldered, it is recommended that some practice be obtained before attaching a plug to a shielded cable. However, the experience gained from work on even one hi-fit kit or radio is ample for this work. For convenience, some simple instructions in plug and cable installation are included in this book. Remember not to apply too much heat, just enough to allow solder flow. Excess heat will melt some plastic insulations, possibly causing a short between the center conductor and the shield.

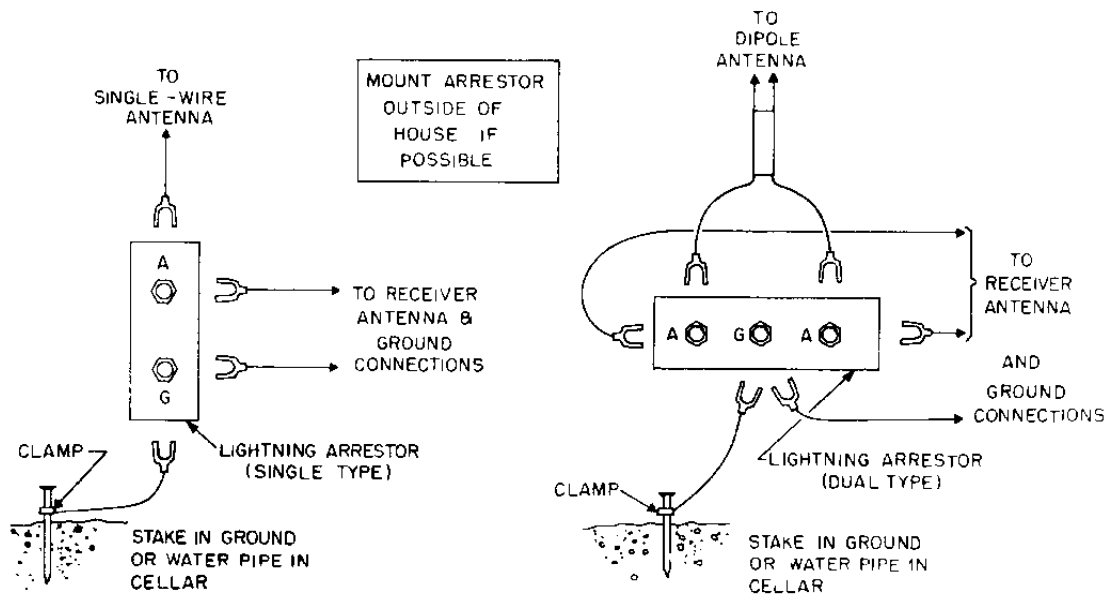

TYPICAL LIGHTNING ARRESTOR INSTALLATIONS

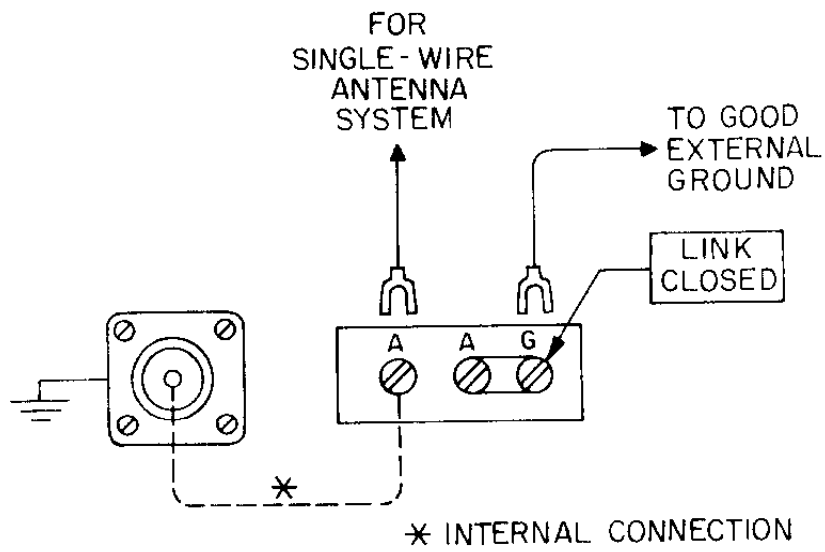

ANTENNA CONNECTIONS FOR SINGLE WIRE ANTENNA

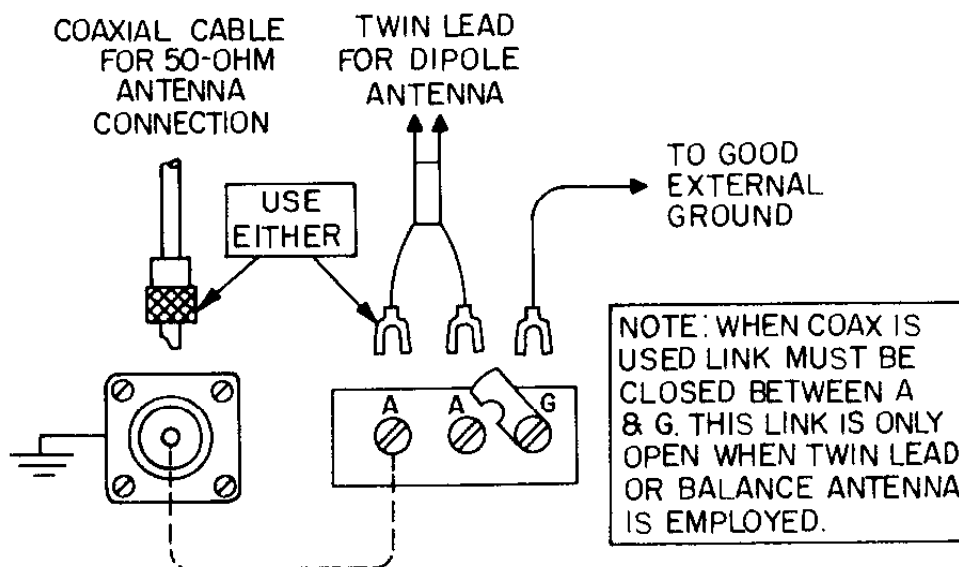

ANTENNA CONNECTIONS FOR DIPOLE ANTENNA

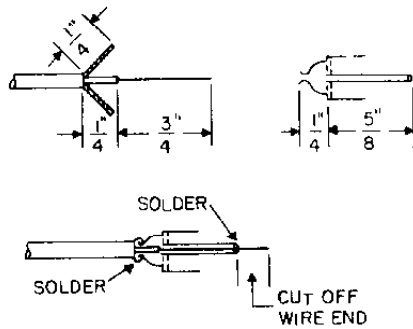

- 1 STRIP INSULATION
- 2 CUT AND SPREAD SHIELD
- 3 INSERT CABLE INTO PLUG, CENTER CONDUCTOR THRU PIN SOLDER CENTER CONDUCTOR, CUT OFF EXCESS.
- 4 SOLDER SHIELD AROUND OUTER NECK OF BODY

CAUTION DO NOT USE TOO MUCH HEAT, CENTER CONDUCTOR INSULATION MELTS EASILY!

ATTACHING SHIELDED CABLE TO PHONO TYPE CONNECTOR

ASSEMBLY OF CABLES TO 83-1SP PLUG USING ADAPTER 83-168 OR 83-185



CUT END OF CABLE EVEN REMOVE VINYL JACKET $\frac{3}{4}$ " SLIDE COUPLING RING AND ADAPTER ON CABLE.

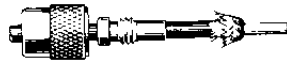

FAN BRAID SLIGHTLY AND FOLD BACK AS SHOWN.

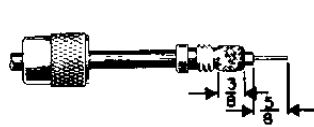

POSITION ADAPTER TO DIMENSION SHOWN. PRESS BRAID DOWN OVER BODY OF ADAPTER AND TRIM TO $\frac{3}{8}$ " BARE $\frac{5}{8}$ " OF CONDUCTOR. TIN EXPOSED CENTER CONDUCTOR.

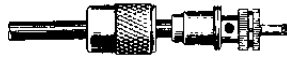

SCREW PLUG SUB-ASSEMBLY ON ADAPTER. SOLDER BRAID TO SHELL THROUGH SOLDER HOLES. USE ENOUGH HEAT TO CREATE BOND OF BRAID TO SHELL. SOLDER CONDUCTOR TO CONTACT.



FOR FINAL ASSEMBLY, SCREW COUPLING RING ON PLUG SUB-ASSEMBLY.

ASSEMBLY OF CABLES TO 83-1SP PLUG

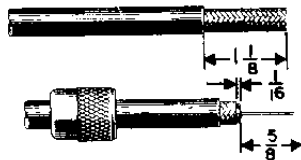

CUT END OF CABLE EVEN. REMOVE VINYL JACKET $\frac{1}{8}$ "

BARE $\frac{5}{8}$ " OF CENTER CONDUCTOR. TRIM BRAIDED SHIELD SLIDE COUPLING RING ON CABLE. TIN EXPOSED CENTER CONDUCTOR AND BRAID.



SCREW THE PLUG SUB-ASSEMBLY ON CABLE SOLDER ASSEMBLY TO BRAID THROUGH SOLDER HOLES. USE ENOUGH HEAT TO CREATE BOND OF BRAID TO SHELL. SOLDER CENTER CONDUCTOR TO CONTACT.

Using 6 and 2 meter converters with the HQ-180 and "A" series receivers

When building or purchasing a converter for 6 or 2 meters, we recommend using an IF frequency of 10.0 to 14.0 mc/s. In the "A" series of receivers the accessory socket may be used for convenience in supplying power to the converter. Consult the Accessory Socket Connections Diagram for the proper plug wiring.

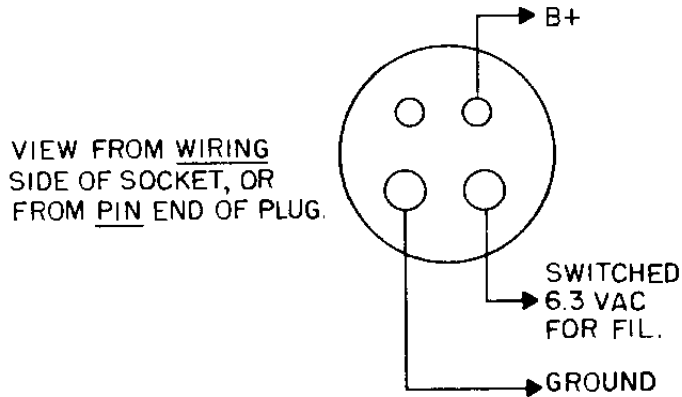

ACCESSORY SOCKET CONNECTIONS

The system socket connections provide for a variety of uses, depending upon the transmitter system installed. (Compatibility with Hammarlund HX-50 or HX-500 Transmitters included. See their instruction manuals for details).

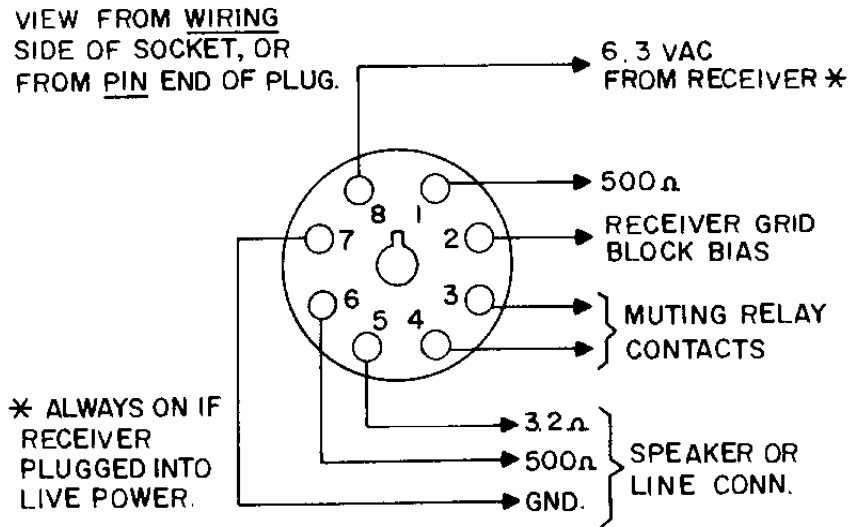

SYSTEM SOCKET CONNECTIONS

"A" SERIES ONLY

HQ-180A OPERATION

With the antenna, speaker and any accessories installed, you are ready to receive transmissions on the amateur bands. These pages are intended to show you the operating methods that will permit the Receiver to give you the best audible signal possible, considering atmospheric and man-made noise. Three most important reminders:

1. Check the listening aids like the noise limiter and slot frequency control -- be sure incorrect setting is not reducing Receiver capability.
2. Always tune the Receiver properly to produce the maximum signal.
3. Don't forget the antenna trimmer -- it requires a different setting on each band. This is because antenna impedance changes with frequency; the trimmer is there to allow for a maximum match at all frequencies.

Plug the Receiver line cord into a 117-volt, 60-cycle line (the export model HQ-180A -E will accommodate 117 or 230 volts, 50 or 60 cycles). Turn the Receiver on, using the RF gain control and the clock timer switch if installed. Check that all tubes are lit. Note that the high-frequency oscillator and mixer tube filaments remain heated at all times, (in the HQ-180A series) if the line cord is left inserted into a source of AC power. Heating of these tubes eliminate drift that occurs in all oscillator circuits as they heat up. Tube life is not reduced through continuous operation. In fact, its life is often extended to many times normal because it is not subjected to the hardships of physical expansion and contraction due to heating and cooling when power is applied and removed. If the receiver is not to be used for extended periods (upwards of 3 days) the line cord should be removed from the power socket. If the oscillator has not been maintained heated, then allow one hour for the Receiver to settle down to a steady tuned condition. Readjust tuning as necessary during this period. Do not attempt to calibrate or set the S-meter until drifting has stopped.

The HQ-180 and "A" Series Receiver is arranged to provide the best reception for AM (voice), for Code (modulated or unmodulated CW), and for SSB (single sideband) operation. To be sure of the best results and the clearest reception, read all of the instructions presented here. Set the controls as shown in each illustration for normal operation, and follow the guidelines to improve performance and to tune over the bands. Become familiar with each control and see what each can do for you. Even after you are familiar in every way with the controls, refer occasionally to these instructions to check that you are still getting the most out of the many features of the HQ-180A.

Finally, your particular location and installation will affect operation; experiment with control settings to obtain the best results. And consult with us if there are any problems. The Receiver is for your enjoyment, use it correctly and it will give you years of service.

The Carrier Level S-meter has been adjusted at the factory for correct and calibrated operation, however, two zero adjustments should be checked and reset if necessary; one is mechanical, the other, electrical.

1. With the Receiver turned off, adjust the meter pointer screw on the front face of the meter to set the needle exactly over the zero mark on the scale.
2. Turn on the Receiver; be sure to allow a 1/2 hour warm-up before proceeding further. Set the HQ-180A to "Receive", and set the RF Gain control fully counterclockwise, without actually turning the set off.
3. Now adjust the meter zero control at the rear of the Receiver chassis again for zero on the meter. A small screwdriver inserted through the chassis is required for this setting. Do NOT adjust the meter sensitivity, this requires a special technique and an input signal generator, not normally available for home use. Check carefully with the rear of chassis illustration to be sure of the location of the meter zero adjust.

HOW TO USE THE BAND SPREAD DIAL

The main dial is provided with markers, just below the scales at 4.04, 7.3, 14, 25, 21.8 and 39.7 mc, to establish points for the approximate set

of the main dial to be used in setting up the amateur scales of the band spread dial.

Set the band spread dial at the 100 kcs point at, or nearest to, the high frequency end of the desired amateur band. The main dial should then be carefully adjusted, close to the high frequency band edge marker, to obtain zero beat with the 100 kcs calibrator. Care must be taken that the proper 100 kcs point is employed in order to prevent setting the main dial 100 kcs higher or lower than the amateur band. Next turn the band spread dial to the 100 kcs marker nearest the desired operating frequency. It may be found that this 100 kcs marker is slightly off the exact dial marker. The dial indicator is set to the exact 100 kcs marker, with the small knob to the right of the band spread dial.

If it is desired to use the band spread dial for other, limited frequency ranges than those for which scales are provided, set the band spread dial at the 100 marker of 0 to 100 arbitrary scale and adjust the main dial for zero

GENERAL OPERATING PROCEDURE (ANY MODE)

1. Select mode -- AM, SSB, CW.
2. Set controls for normal operation as shown on the mode illustration -- AVC, RECEIVE, SIDEBANDS, SELECT KCS -- NOISE LIMITER off, SLOT FREQ \neq 5 KCS, BFO centered, VERNIER TUNING zero.
3. Tune in station -- TUNING RANGE, MAIN TUNING, AF and RF GAIN, ANTENNA TRIMMER -- use BAND SPREAD for bandspread, and VERNIER TUNING for single side band intelligibility.
4. Readjust special controls for signal reception improvement, noise or interference elimination, etc. -- NOISE LIMITER, AVC, CALIBRATE, SIDEBANDS, SELECT KCS, BFO, SLOT FREQ.

OPERATION NOTES

AM RECEPTION

1. To obtain maximum fidelity, the widest bandwidth is normally used. However, under conditions of severe interference from spurious signals or atmospheric noise, the bandwidth is reduced to improve intelligibility although some sacrifice of fidelity results. Adjust bandwidth for best reception.
2. The Slot Frequency control provides an extremely sharp adjustable slot or hole in the selectivity curve. It is normally located outside of the passband of the second IF (455kc/s). It is brought into the passband for the purpose of eliminating interference from heterodyne signals on AM and reducing "monkey chatter" on SSB. On CW reception it will materially aid in reducing or eliminating adjacent or co-channel interference.

Whenever the receiver is being tuned for normal reception be sure to first rotate the Slot Frequency control to either minus 5KC or plus 5KC for normal tuning or the center of the passband will be slotted out, producing 2 spot or 2 peak "S" meter readings.

The Slot Depth control (located behind the front panel) is a very gradual vernier adjustment. In view of this, its effect will not be very noticeable unless proper procedure is employed. This procedure is explained in the service section of this manual. As this control is properly adjusted at the factory, the setting should not have to be changed unless changes have taken place in the circuitry due to component aging etc.

3. The automatic noise limiter can reduce noise to the point where its audio level is electrically no higher than the desired signal level. This point is indicated by the start of audio level decrease as the limiter control is rotated clockwise. The proper setting for this control is therefore at the point just before the audio output of the desired signal is reduced. Further rotation decreases noise and signal equally without improving signal-to-noise ratio.

CODE AND SINGLE SIDEBAND RECEPTION

4. Interrupted continuous-wave (ICW) transmissions do not normally provide steady signals for S-meter readings. However, readings can be made fairly well in CW reception using the "SLOW" AVC position of the AVC switch. In any case tune for the loudest signal level heard.
5. The 100 KCS multiples of the Crystal Calibrator will be found at or near the one decimal numbers only, such as 1.9, 14.3, etc. when the Send/Rec/Cal switch is in the Cal position. (Read "How To Use The Band Spread Dial" in the Operation section of this manual.)
6. For code reception, never set tone by adjusting main tuning, because this detunes the Receiver. Always set BFO to zero first, tune receiver for zero beat, THEN set BFO for desired tone.
7. On SSB, carrier level meter fluctuates with audio. Tune for maximum audio or apparent S-meter level.
8. SSB, (Single Side Band) signals can be identified by the lack of a carrier or beat note ("whistle") when tuning across the signal. A Single Side Band signal NOT properly tuned in will sound scrambled and extremely nasal. Adjust the Main Tuning dial for maximum signal strength (to be judged by ear or S-meter). Adjust the Vernier Tuning for maximum speech intelligibility. (The Vernier Tuning must be tuned slowly for effectiveness) Intelligibility can only be obtained by proper choice of upper (u) or lower (l) sideband reception. The BFO (Beat Frequency Oscillator) control is disconnected in SSB position.
9. The accepted or most popular transmission of single sideband signals insofar as the sideband used will usually be as follows:

75 meters	3.8 to 4 mc	Lower Sideband
40 meters	7.0 to 7.2 mc	Lower Sideband
20 meters	14.200 to 14.350 mc	Upper Sideband
15 meters	21.250 to 21.450 mc	Upper Sideband
10 meters	28.6 to 28.7 mc	Upper Sideband

The use of upper or lower sideband will vary on the other bands covered by this receiver and it is not unusual for the other sideband to be used on the above mentioned bands. If a SSB signal cannot be made intelligible using the vernier tuning control, change to the other sideband switch position.

HQ-180A MAINTENANCE

This receiver has been carefully constructed, inspected, adjusted and aligned at the factory to provide a long period of trouble-free use. Unless you have the proper equipment and the detailed knowledge to service complex electronic circuitry, it is not recommended that any other maintenance but tube testing be attempted. In particular, DO NOT ADJUST TRIMMERS OR

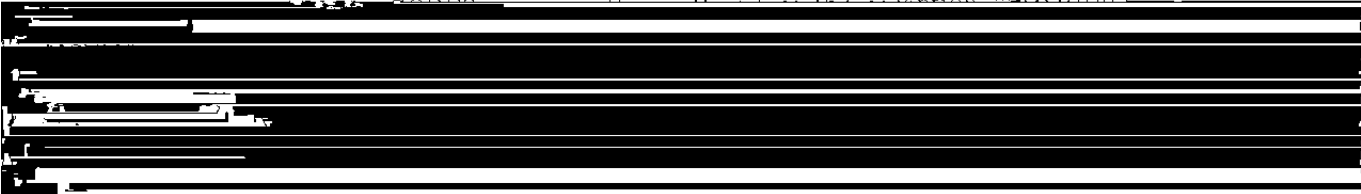

changing tubes and by making a few minor adjustments, but in order to properly service this set it is important to be able to diagnose obscure troubles through an understanding of the circuits involved. It is for this purpose that this section is provided. A communications receiver of this type contains several special circuits not normally included in the home radio. Examples of such circuits are the BFO (beat frequency oscillator), the slot, triple conversion, delayed AVC (automatic volume control), etc.

The complete circuitry of the HQ-180 and "A" Series, is shown in the schematic diagrams included at the end of this book. To help in understanding these diagrams, a block version is presented on the next page. While reading the test, follow both the block and schematic diagrams -- one will illustrate the overall system, while the other will provide all of the connection details.

The "X" series of receivers provides an eleven position fixed frequency crystal oscillator assembly which is factory installed in the panel space provided for the 24 hour clock timer. The knob allows selection of normal variable frequency tuning or any one of eleven fixed frequencies crystal controlled. Six crystals are mounted on the front plate of the oscillator assembly and may be changed quite readily to shift frequencies. The remaining five crystals are mounted behind the front panel on the oscillator box and may be changed by lifting the top cover of the cabinet. It is intended that the five inside crystals will be for commonly used channels not subject to being changed very often. The receiver can be zeroed into the channel frequency by manipulating the vernier tuning control on the front panel. This will correct for frequency discrepancy due to crystal tolerance and assure accurate "netting".

The use of the crystal controlled oscillator will permit the highly stable reception of signals on the eleven channels selected. The only operation required besides turning the selector switch to the desired crystal position is to turn the band switch to the desired crystal position and tune the main dial to the approximate frequency rocking the knob for maximum "S" meter indication.

In order to ensure proper operation, the crystals should be ordered from your local authorized Hammarlund distributor.

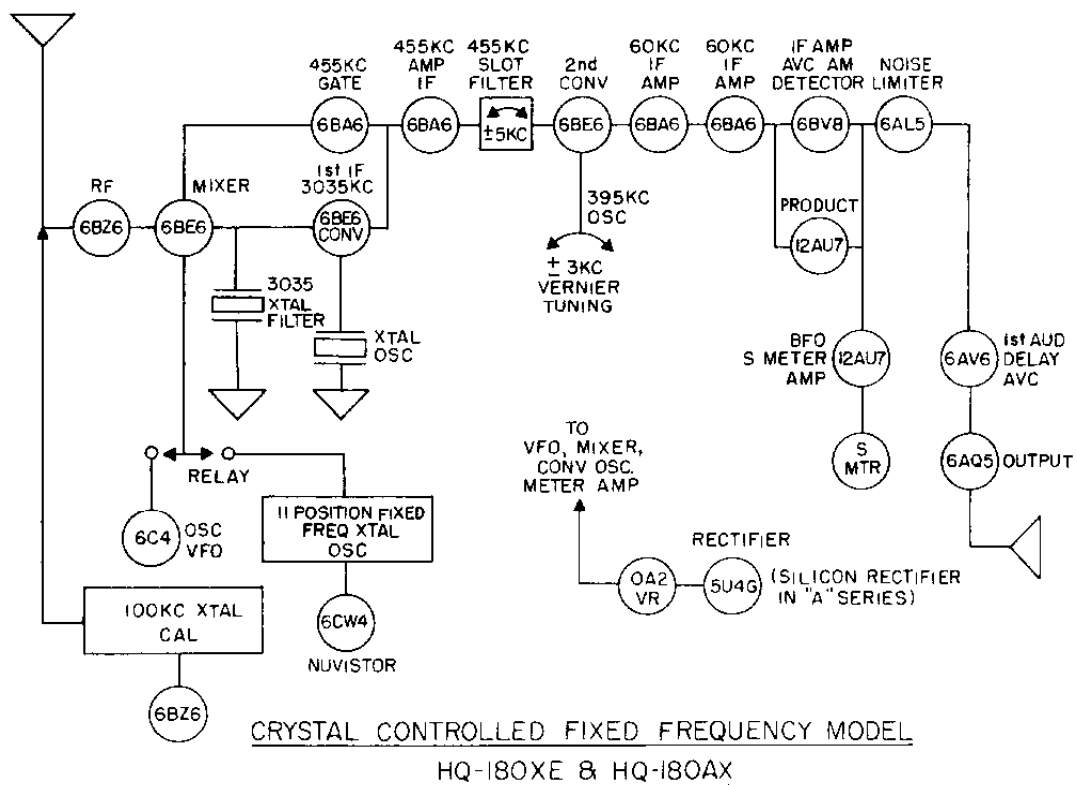
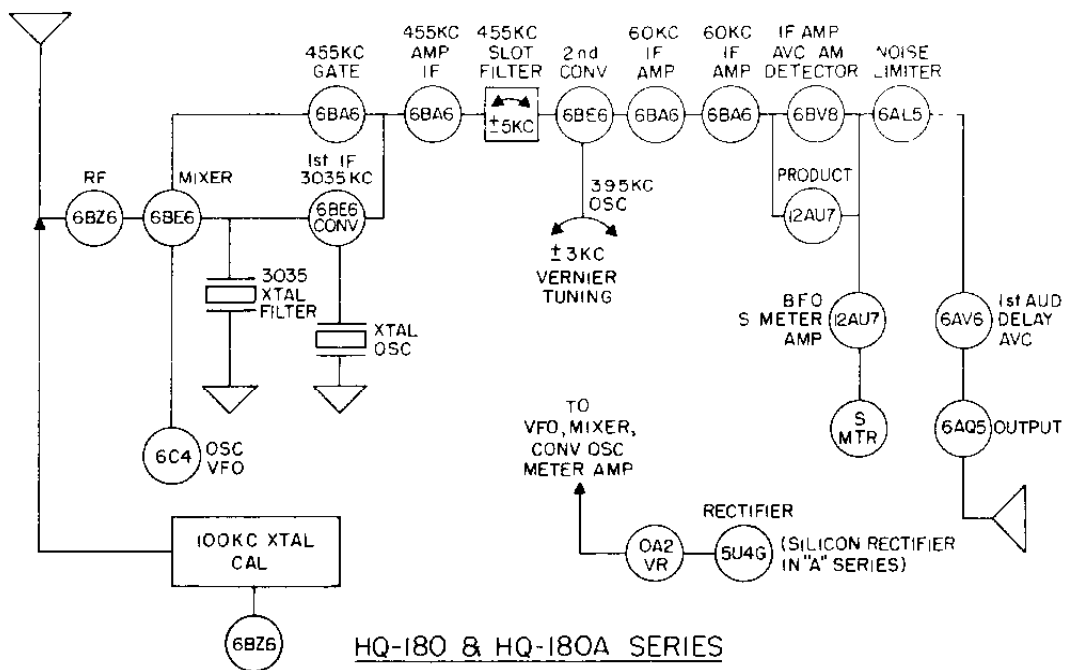

The oscillator or actual crystal frequency for a given signal frequency shall be determined from the following:

<u>SIGNAL FREQUENCY</u> <u>RANGE mc</u>	<u>ADD IF-----</u> <u>FREQUENCY mc</u>	<u>SUBTRACT IF-</u> <u>FREQUENCY mc</u>	<u>MODE OF</u> <u>OPERATION</u>
.54 to 1.05 mc	.455000		Fundamental
1.05 to 2.05 mc	.455000		Fundamental
2.05 to 4. mc	.455000		Fundamental
4.0 to 7.85 mc	.455000		Fundamental
7.85 to 15.35 mc	3.035		Fundamental
15.35 to 20.662 mc	3.035		Fundamental
20.662 to 30.000 mc		3.035	2nd Harmonic

NOTE: WHERE LOW SIDE INJECTION IS SPECIFIED, HIGH SIDE INJECTION MAY BE USED AT REDUCED SENSITIVITY.

The RF signal is received at the antenna and applied to the RF amplifier through the antenna terminal strip or shielded connectors, and through the band-switched antenna tuned circuit. The antenna trimmer, compensating for differing antenna characteristics at differing frequencies, is located across the secondary of the antenna transformer. The calibration oscillator, turned on in the calibrate position, applies its signal to the RF amplifier. This oscillator is a crystal controlled type at 100 KCS, developing a very large number of 100 KCS harmonics to cover all of the bands in the Receiver.

To control the Receiver sensitivity, one section of the RF gain control sets the bias of the RF amplifier stage. Rotating the control clockwise decreases tube bias, permitting increased amplification and thereby increasing sensitivity to weaker signals.

From the RF amplifier the signal is applied to the first mixer where it is heterodyned with the output of a separate high frequency oscillator. The resulting frequency is the first intermediate frequency (IF). From .54 to 7.85 mc/s the HF oscillator is located 455 kc/s above the signal frequency. From 7.85 to 30 mc/s the HF oscillator is 3035 kc/s above the signal frequency. When operating the 7.85 to 30 mc/s bands, the difference frequency of 3035 kc/s is fed through a crystal filter and is heterodyned with 2580 ,~~kc/s~~ crystal controlled oscillator in the converter tube to produce 455 kc/s 2nd IF. When the Band Selector switch indicates .54 to 7.85 mc/s the converter tube ceases to function and the gate tube becomes a regular 455 kc/s amplifier. Band switching and frequency tuning occurs in the grids of the mixer and of the oscillator. The arrangement of heterodyning used in this Receiver is listed in the accompanying chart. The stability of the oscillator circuit, a must for accurate and repeatable tuning, is maintained by using a separate tube, and keeping the heater supply on at all times, minimizing drift tendencies. In the "A" series only, the filament is supplied with power through filament transformer T30 as long as the line cord is connected to a source of power. If the clock is mounted, power will be required at all times.

The chart of the heterodyning system shows that the second mixer becomes a 455 KCS amplifier on the two lowest frequency bands. Section 32E of the band switch accomplishes this by removing the crystal circuit from the oscillator portion of the tube at this time. When the oscillator is allowed to work, the first IF signal beats with the oscillator signal to become the second IF.

V4 is a 455 KCS amplifier whose gain is also controlled by a second section of the RF gain control, resulting in receiver sensitivity adjustment in the same manner as before.

Before the 455 KCS signal is applied to the third mixer, it is passed through the slot circuit. This circuit is designed to provide a narrow section of frequency rejection capable of being set precisely on an interfering signal. The

for best results. The diagrams show the characteristics and the capacitance of this circuit.

BAND	Frequencies in KCS							
	MCSE	RF	1st OSC	1st IF	2nd OSC	2nd IF	3rd OSC	3rd IF
1.05 - 2.05	S	S \neq 455	455	(Amplifier Stage)	395	60		
2.05 - 4.0	S	S \neq 455	455	(Amplifier Stage)	395	60		
4.0 - 7.85	S	S \neq 455	455	(Amplifier Stage)	395	60		
7.85 - 15.35	S	S \neq 3035	3035	2580	455	395	60	
15.35 - 30.0	S	S \neq 3035	3035	2580	455	395	60	

S = Signal Frequency Received

CHART OF FREQUENCY HETERODYNING

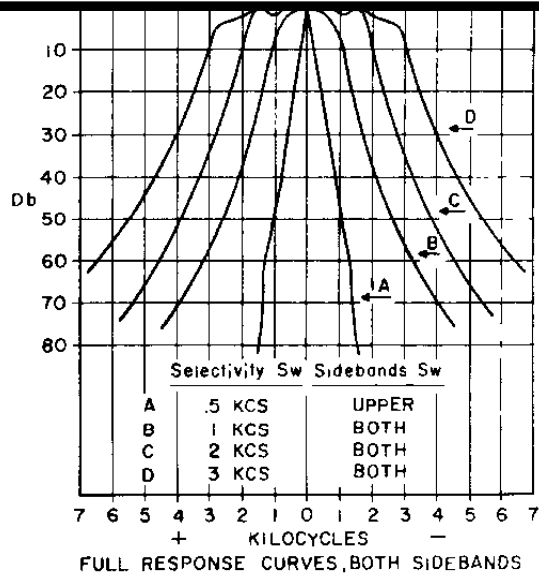
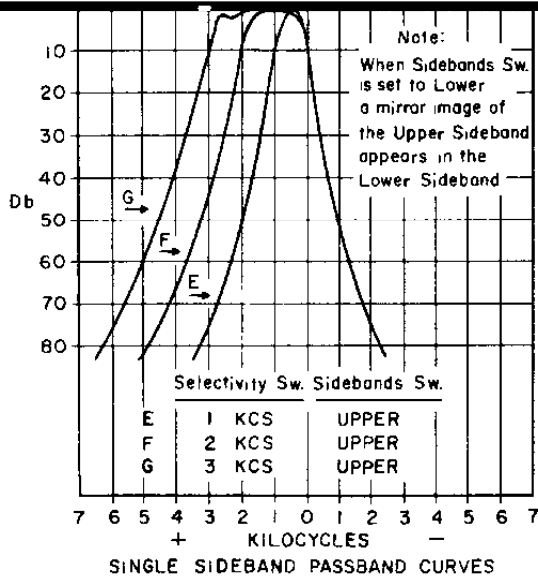
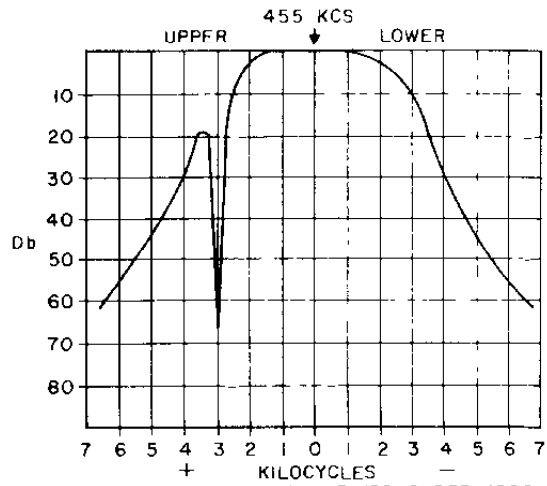
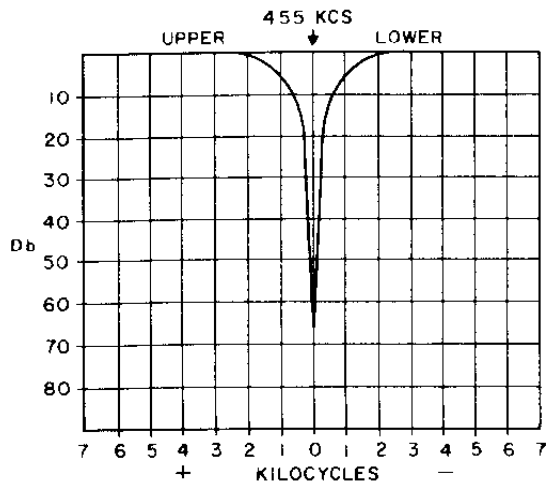

Conversion again occurs to result in a third IF of 60 KCS. Three stages of 60 KCS IF amplification are provided along with means for adjusting the selectivity of the receiver to aid in the rejection of unwanted interfering signals. This is especially useful for code reception where little sidebands are transmitted. A wide band receiver is a detriment here because of such a receiver's capability of amplifying all nearby stations almost as well as the one to be listened to. For single sideband operation, a second switch permits setting the receiver passband for maximum reception only on the side of the carrier required for reception.

The signal delivered from the 60 KCS amplifier stages is then applied to four separate detector circuits, two for efficient audio development, and two for the generation of correct AVC voltages that will assure the best possible reception of all types and levels of RF signals. The general block diagram shows that AM reception is handled by a normal diode detector circuit. See the simplified schematic of the detector, BFO and noise limiter circuits. In the AM position, the resulting audio is passed through the noise limiter tube V10 and on to the audio gain control.

In the CW position, V9 acts as a product detector, and the audio is developed from the beat between the incoming 60 KCS and the output of the BFO at a frequency that is at or near 60 KCS depending on the setting of the BFO control. The BFO is aligned so that zero beat occurs when the BFO control is centered. The audio output is then taken from the junction of R73 and R74 and applied through the CW position of the mode switch to V10 in the same manner as for the AM audio.

Single sideband detection is exactly the same as for CW except that the BFO is a fixed frequency in the "A" series. For the HQ-180 series, keep BFO control at "0". In SSB operation tuning for intelligibility requires that the suppressed carrier be replaced within the receiver. The BFO does just that, the vernier tuning dial being used to precisely tune the receiver to the sideband that has been transmitted. The heterodyning between the BFO frequency and the received sideband produces audio in the same manner as audio is produced for CW.

The noise limiter is a very useful circuit that is designed to assure that no noise or interference signal peaks will be higher than the wanted signal. In the "OFF" position, B+ is applied to the plates of V10, while the cathodes are grounded. Since the tube sections are conducting, any signal applied to V10 from the detectors is passed through to the audio gain control. In the "ON" position, the plates are connected to ground, while B+ is applied to the cathodes through the noise limiter control. The circuit is arranged that when the control is at its counterclockwise end of rotation, audio is permitted to pass through almost unreduced. As the control is turned clockwise, the B+ applied to the cathodes increases so that strong peaks are clipped. In operation, it will be noted that the noise limiter is used to clip noise peaks that are higher than the desired audio; the control is therefore turned clockwise until it is noted that the wanted audio starts to be clipped (volume reduced). The correct position of the control is just below the point where this occurs. At this point, maximum clipping is occurring without reducing the wanted signal. The noise limiter is capable of operation on any type of signal, but it should be noted that less noise and interference can often be obtained by reducing the receiver bandwidth as well.

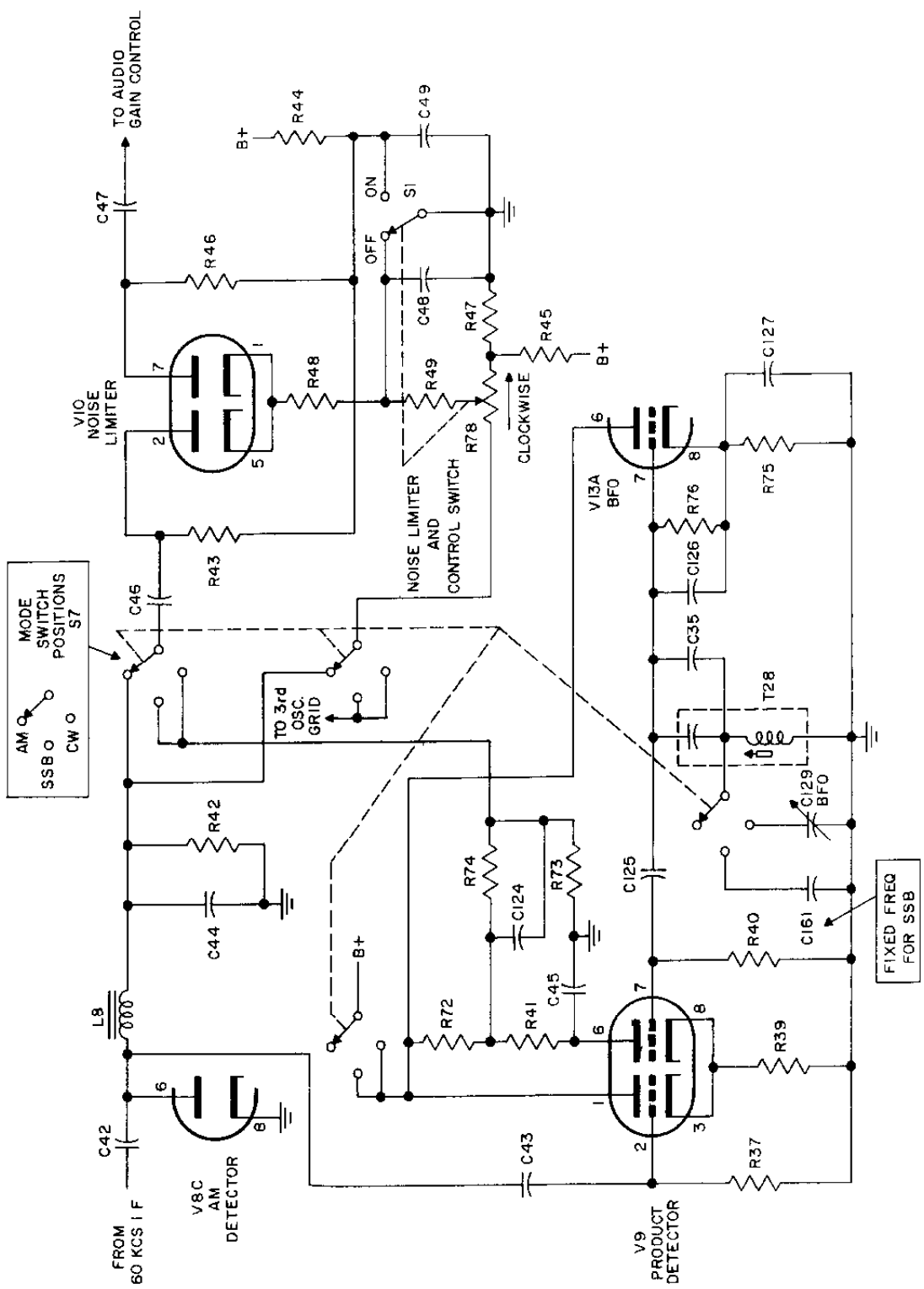

DETECTOR, BFO & NOISE LIMITER CIRCUITS

Automatic volume control voltages are developed from the two circuits illustrated. RF detection takes place through both V8B and the diode section of V16. Each circuit is arranged to reduce a negative voltage that will increase as the received signal increases. Except in the "OFF" position, AVC voltages are applied to the RF amplifier, to the 2nd IF amplifier, to the 3rd mixer, and to the 1st 60 KCS IF amplifier. The positive voltage developed across R92 prevents AVC from being applied to the RF amplifier until the incoming signal is high enough to overcome it. This delayed AVC improves the reception of weak signals.

The other AVC circuit is not biased in this fashion, but it is designed to allow for an adjustable decay characteristic. AVC is applied immediately, but its decay in the event of fading is adjustable to be slow, medium or fast depending on the type of signal and on the atmospheric conditions of the time. R83, R84 and R85 set the discharge time of C131, creating the appropriate AVC decay.

The carrier level "S" meter circuit operates on the same AVC signal just described. The circuit is a bridge, with the tube and R88 on one side, and R21, R20 and R22 with its switched resistors on the other. The meter is in the center of the bridge, set to zero in the absence of a signal (AVC zero). When a signal is received, AVC is developed, the tube current changes to unbalance the bridge, and the meter reads. The greater the signal, the greater the unbalance, and the higher the meter reading. The sensitivity setting is made only when a signal of known strength is applied to the receiver, usually from a precise signal generator whose output level can accurately be measured.

The audio stages are conventional in nature, except for the special auto-response circuit illustrated. This is a negative feedback system that provides maximum effect at low audio gain control settings. Strong signals are then permitted the highest fidelity of response and lowest distortion, while increasing the gain on weak signals narrows the audio response to improve signal selectivity. An improved signal-to-noise ratio results. A further advantage is the critical damping of the speaker for elimination of speaker resonance effects. Speech reception is improved and receiver output noise is reduced.

The receiver power supply is arranged to permit the 1st oscillator and mixer to remain heated even when the rest of the set is turned off (in the "A" series only). As has been previously mentioned, this to provide increased receiver stability. The schematic diagram shows these tubes heated from a separate filament transformer, connected to the power line through only the fuse. The electric clock timer is also connected to the line in the same manner. The timer switch mechanism is in series with the normal on-off switch so that the set can be turned on automatically at any desired time. The timer mechanism is designed that it must be turned off manually to reset the mechanism for automatic turn-on in the next 24-hour period.

Plate voltage regulation is enhanced through the use of silicon rectifiers (in the "A" series only), and further stability is established with a gas regulator tube for the critical RF stages and for the calibrated "S" meter.

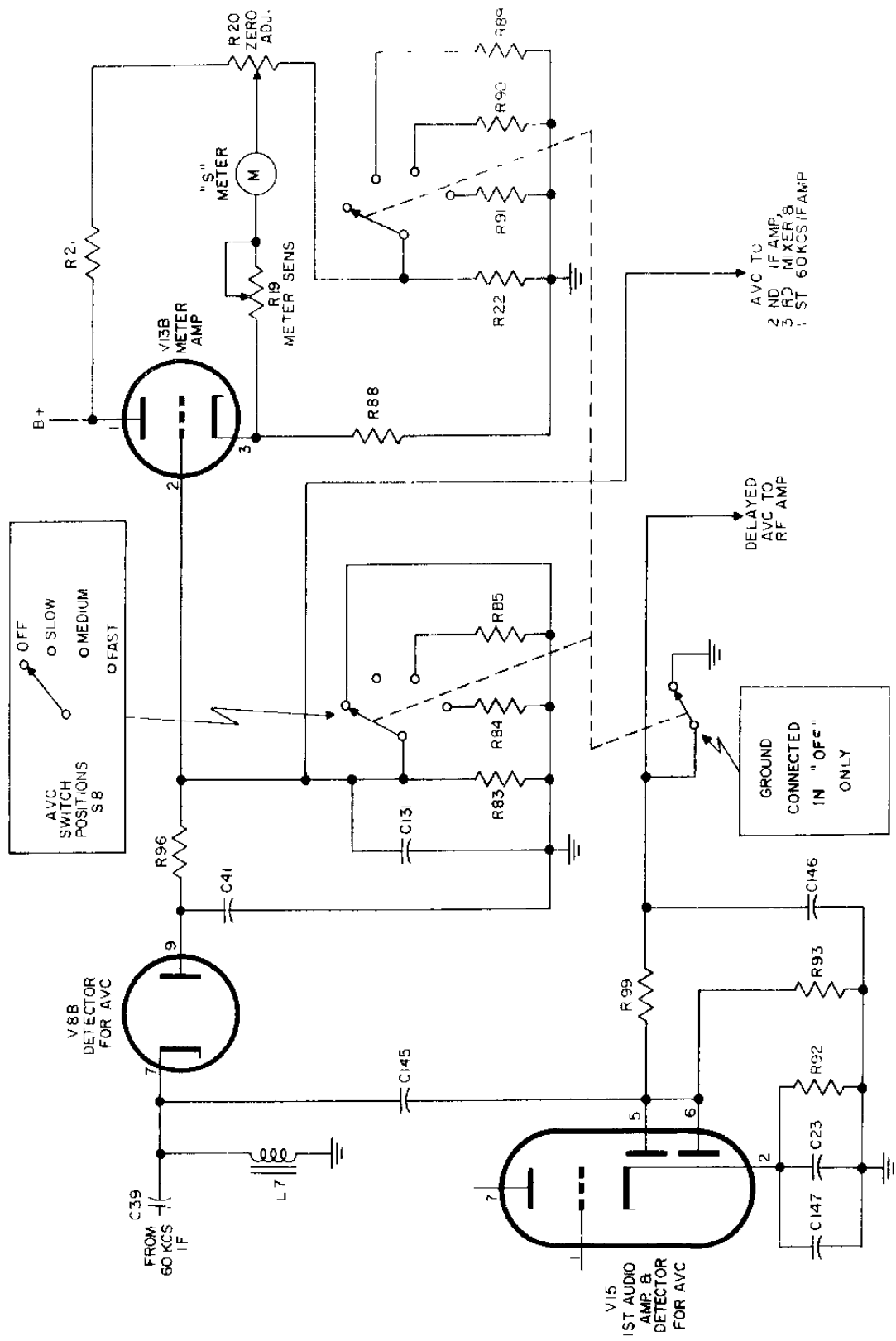

AVC TO:
 1. 1ST 60KCS IF AMP
 2. 2ND IF AMP
 3. 3RD MIXER

DELAYED
 AVC TO
 RF AMP

GROUND
 CONNECTED
 IN "OFF"
 ONLY

AVC 8 "S" METER CIRCUITS

Except for the power transformer primary connections, the supply circuitry for the export version is the same.

Finally, there are the accessory and system sockets, and the send-receive switch, each clearly illustrated on the schematic diagram and self-explanatory. In the send position, the B ∇ to the RF amplifier, the 2nd mixer and the 2nd IF amplifier is removed, muting the receiver. Further or alternate muting can be applied through the system socket from the transmitter (in the "A" series only).

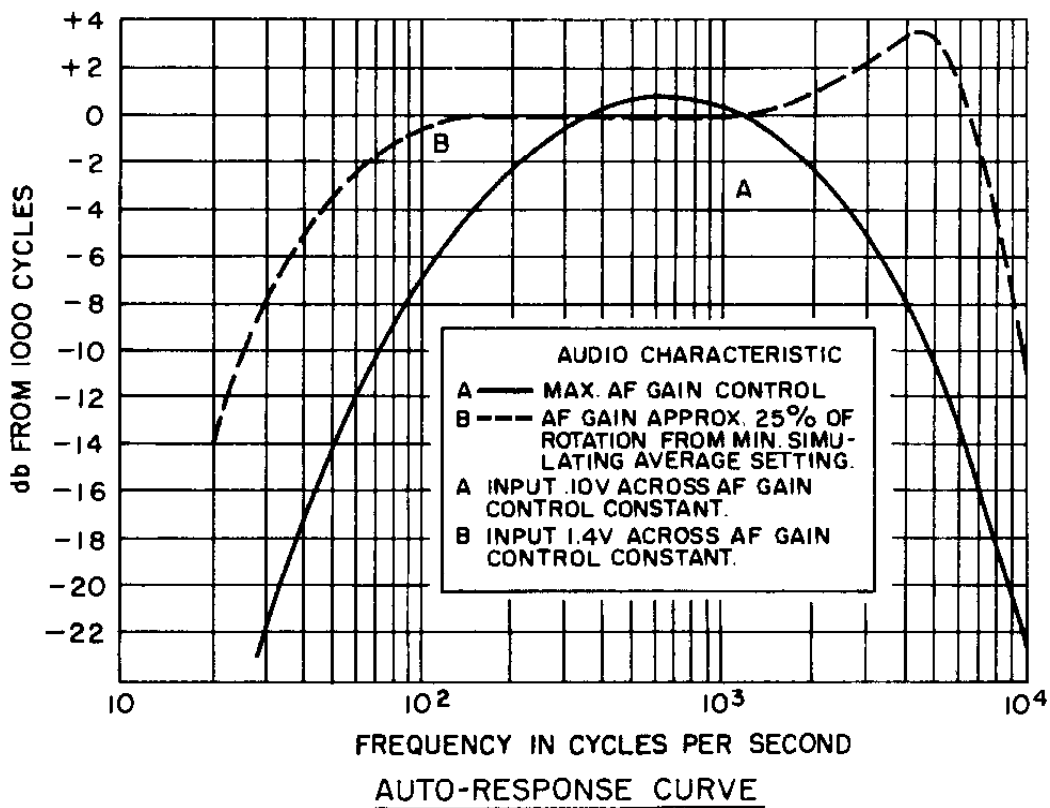

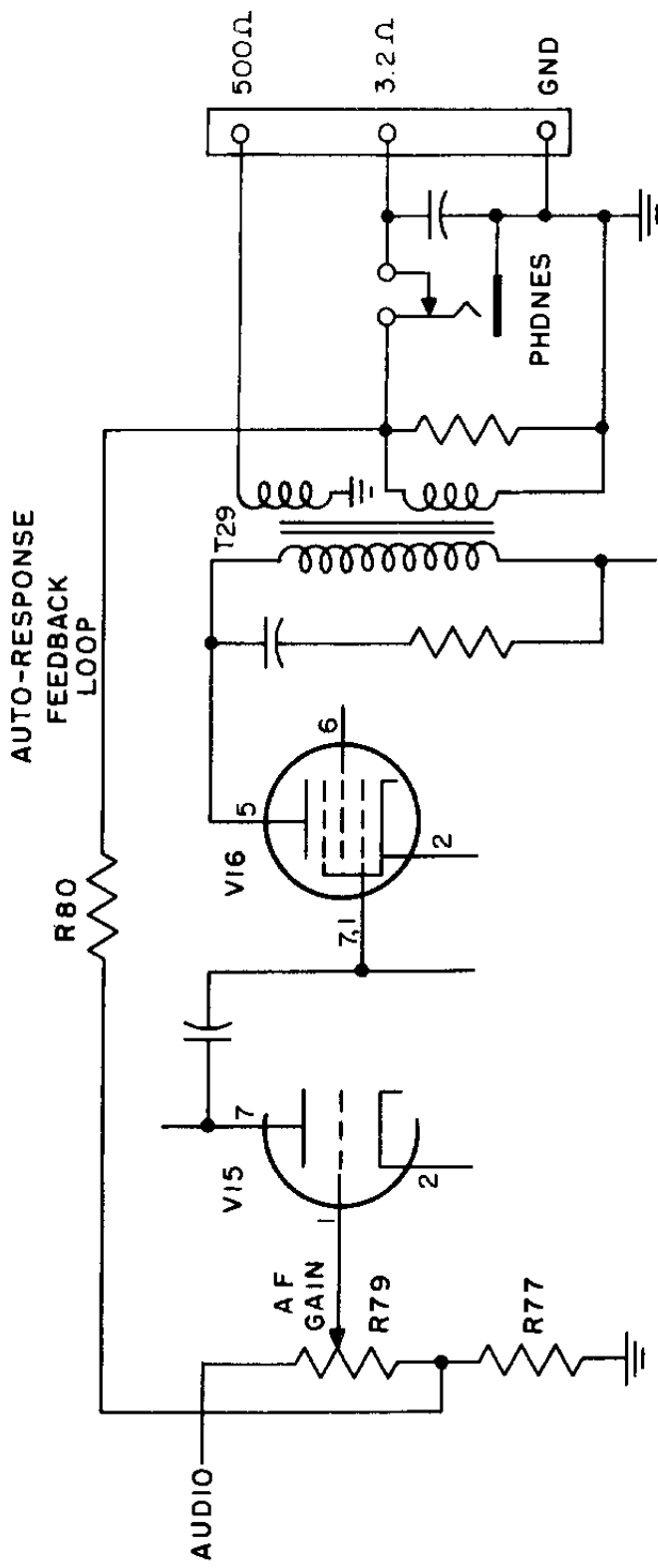

AUTO-RESPONSE CIRCUIT

HQ-180A SERVICE AND MAINTENANCE

This section will provide the instructions for the correct servicing of the Receiver. While no particularly unusual procedures are called for, it should be noted that proper tools and test equipment must be available to undertake the electrical alignment. Inadequate or inaccurate test equipment may result in generally poor operating results.

Excessive oscillator drift which is most noticeable on all of the high frequency bands plus a microphonic condition, is usually the result of a poor 6C4 (V12) high frequency oscillator. This tube is also capable of producing a poor beat note with a ripple in it, also especially noticeable on the high bands. Excessive drift can also be attributed to a poor 6BE6 (V2). This tube can also cause hum modulation most evident on the two highest frequency bands. Sometimes interchanging the 6BE6s between V2 and V3 can produce a noticeable improvement.

Normally there is no reason to remove the chassis from the cabinet, because the top cover allows access to all of the tubes, and to the clock adjustment. However, in the case of RF and IF alignment, it will be necessary to take the chassis out to gain access to the under-chassis alignment settings.

Further disassembly is not recommended except in the case of dial cord replacement. As this is a steel cable, breakage is unlikely, but if it should, it will be required to remove the front panel from the chassis, and to remove the two calibrated dials.

The instructions for the removal of the chassis from the cabinet, and for the disassembly of the front panel, are presented here. Follow the instruction steps with care, and there will be no trouble identifying and replacing all of the parts. Note particularly the knob and dial alignment procedures.

Removing Receiver Chassis from the Cabinet

1. Disconnect all wires and cables at the rear of the chassis.
 2. Tip the cabinet up from the front and remove the hex head screw on the bottom.
 3. Remove the three hex head screws at the back of the cabinet.
 4. Loosen the two Phillips head screws at the top front of the cabinet; do not
-
5. Slide the panel and chassis forward to clear the cabinet. Guide the line cord as necessary. It is advisable to set the chassis down so that the panel overhangs the edge of a table. This will protect the panel finish, and relieve strain on the panel mounting screws.

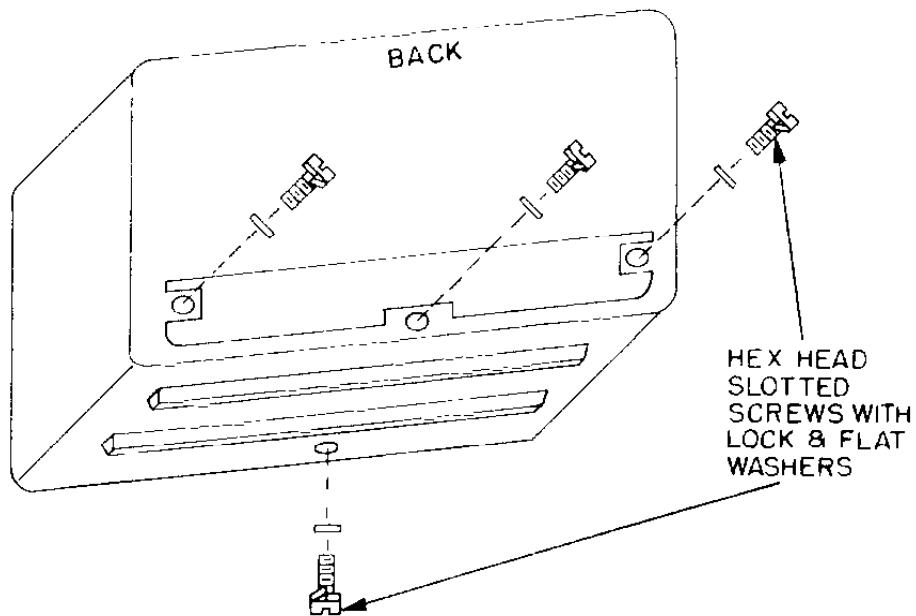
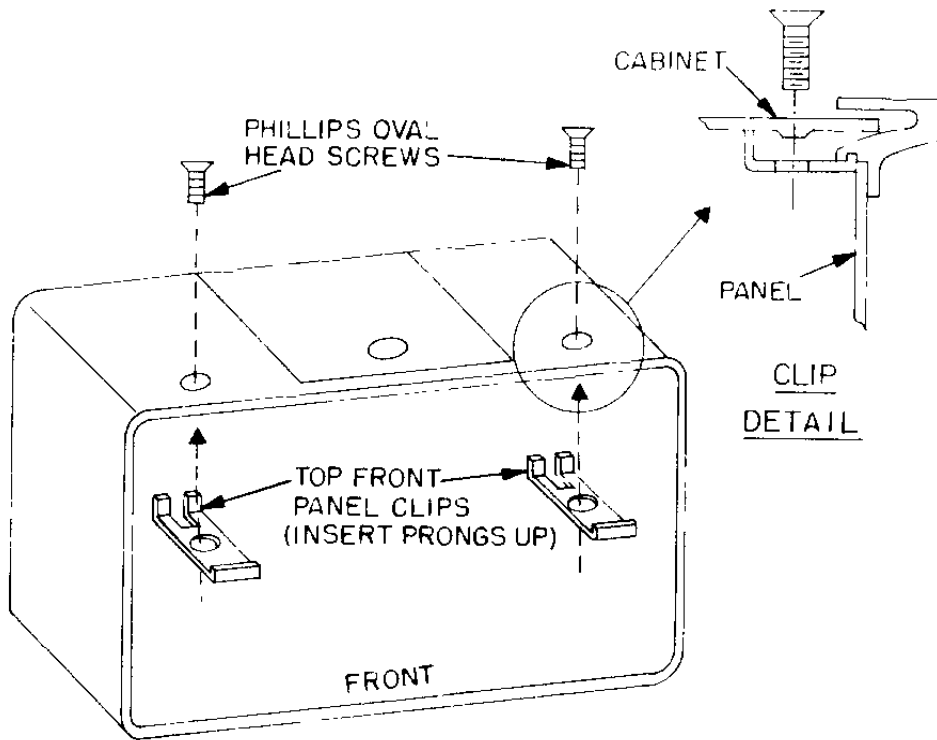

HARDWARE TO FASTEN CHASSIS TO
CABINET

Replacing Receiver Chassis in the Cabinet

1. Slide the chassis and panel into the cabinet, guiding the line cord through the rear opening as necessary. Check that the "L" bracket under the chassis does not catch under the cabinet as the chassis is slid into it. Make sure the cabinet edges are fitted into the slot around the inside edge of the panel. Check that the clips fit under the panel edge as shown in the illustration.
2. Insert the three screws, lock and flat washers in the back of the cabinet. Do not tighten firmly yet.
3. Tip up the cabinet and insert the screw, lock and flat washer in the bottom front of the cabinet. Do not tighten yet.
4. Tighten the three screws in the rear first, then tighten the screw on the bottom.
5. Tighten the two Phillips head screws in the top of the cabinet.

Removal of the Front Panel from the Chassis

Refer to the diagrams for the locations and identification of all parts.

- Step 1. Remove all knobs except those of the clock and dial calibration. Turn all capacitors so that their plates are fully meshed.
- Step 2. Remove the following:
- Nuts from the controls shown on the diagram.
 - Nut and lock washer from the headphone jack.
 - Screws and lock washers from the capacitors.
 - Pry off the two red pointers; be careful not to bend them.
- Step 3. On the back of the front panel, remove the following:
- Large nuts and fiber washers.
 - Dial calibration drive discs.
 - "S" meter lamp assembly.
- Unsolder the two wires to the meter, and the three wires on the clock.
- Pull off the other two lamp assemblies for working convenience in later steps.
- Step 4. On the front of the panel, remove:
- Four Phillips screws and nuts.
 - One smaller Phillips screw and "L" bracket. Hold panel to prevent it from falling as the last screw is removed.

This completes the removal of the front panel.

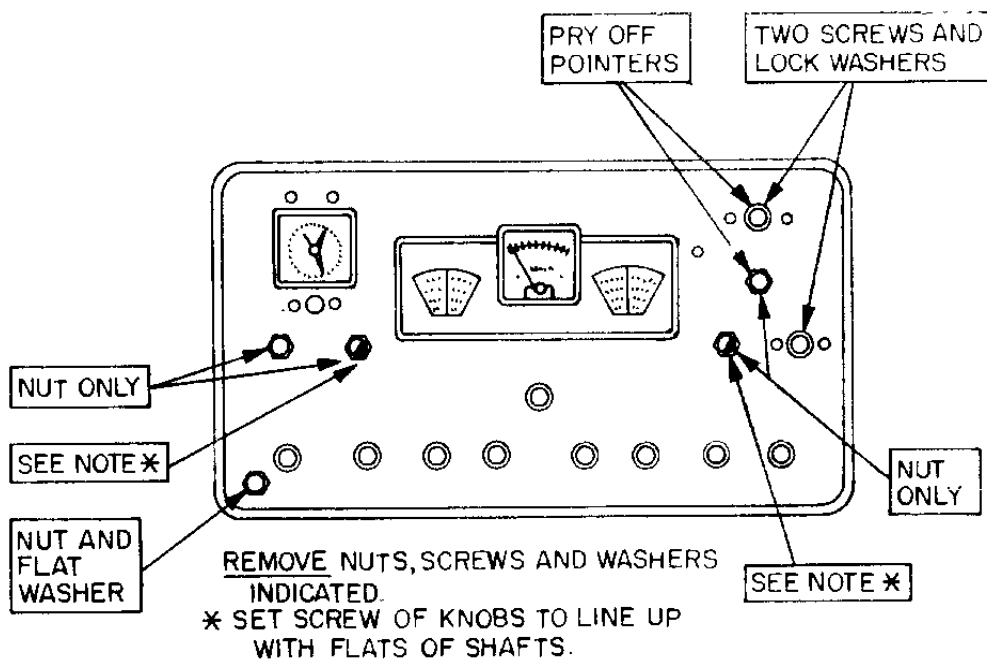

CAUTION TO PREVENT DAMAGE TO CAPACITOR PLATES, MAKE SURE THEY ARE FULLY MESHED.

STEP 2

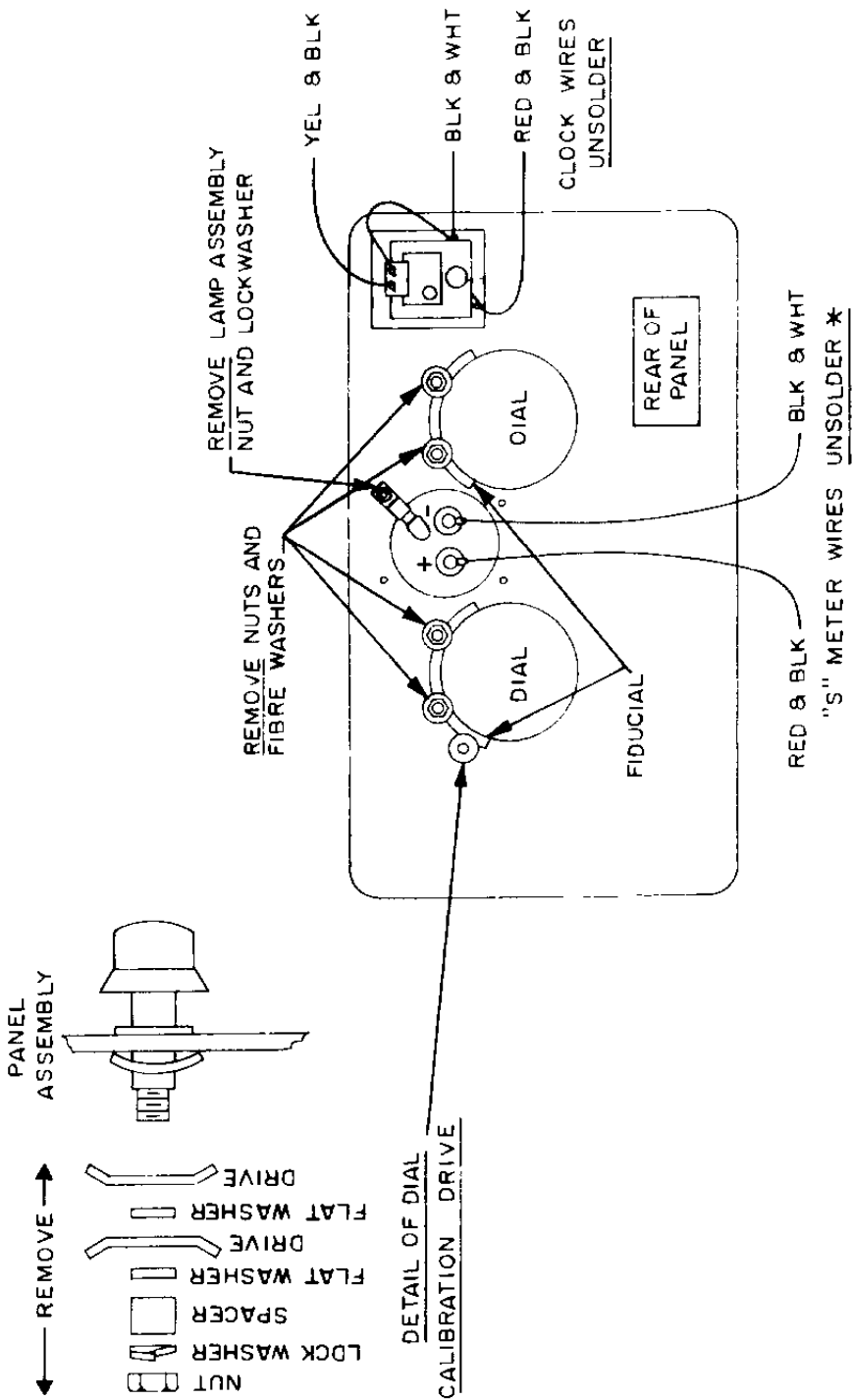

REMOVE AND UNSOLDER AS INDICATED - FOR CONVENIENCE, - PULL OFF OTHER TWO LAMP HOLDERS

* DO NOT REMOVE NUTS FROM METER, THESE ARE INTERNAL MOUNTING STUDS

- Step 5. Loosen but do not remove the set screws on the two dials. DO NOT MOVE THE SET SCREWS OF THE PULLEYS. Now pull the two dial assemblies forward, at the same time guiding the left dial out of the tuning drive discs.

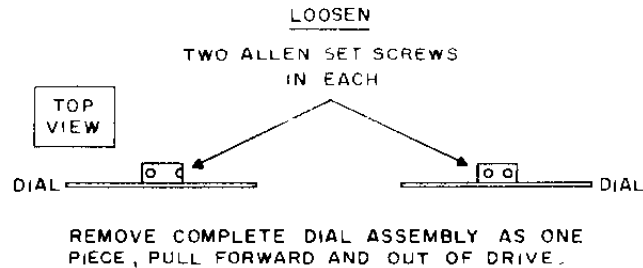

STEP 5

- Step 6. Replace the two dial assemblies on their shafts, inserting the left dial into the tuning drive discs. Make sure that the tuning capacitor plates are fully meshed, then turn the dials so that the left end of each dial is approximately vertical.

Push on the dials so that the shaft ends are about 1/8 inch recessed. It should be possible to see the previous set screw marks on the shafts to help in this setting.

Now tighten one set screw on each shaft. Final setting will come in a later step.

- Step 7. Check that the proper nuts and lock washers are in place on the controls that were removed from the front panel.

Locate the panel in place, inserting the controls in their proper holes.

Secure the front panel by replacing the hardware removed in Step 4.

Note that the "L" bracket fits over the small terminal strip located inside the chassis.

Step 8. On the back of the front panel, replace the hardware removed in Step 2. Check that the dial calibration drive is correctly restored with the transparent segment within the discs. Resolder the wires to the meter and to the clock; see the Step 3 illustration for the wire color code.

Step 9. On the front of the panel, replace the hardware removed in Step 2. Be careful not to scratch the panel when tightening the nuts, and remember to line up the flats of the two controls indicated in the Step 2 illustration.

After Step 9 is completed, check that the dials and the dial calibration system operate smoothly and without interference. If necessary, loosen the front panel screws of Step 4 and readjust panel positioning to obtain proper dial operation.

Step 10. Replace the two red pointers by pushing them onto the inner shafts. Be careful not to bend them. Follow the instructions on the Step 11 diagram for capacitor plate meshing, then replace all knobs. Knob identification appears in the Step 1 illustration.

Step 11. This step is for dial alignment.

Reconnect the Receiver and turn it on. Allow it to warm up for about a half hour.

After the warm-up period, tune in to 4 MCS on the Main Tuning Dial and 100 on the logging scale of the Band Spread Dial, and turn on the crystal calibrator (see instructions in the User's Manual).

Set the dial calibrator so that the hairline is in line with the mark at the top of the scale in the dial sketchbook.



Loosen the left dial set screw, hold the capacitor pulley to maintain zero beat, then set the dial to exactly 4 MCS. Now tighten the dial set screw again FIRMLY.

Turn the dial to gain access to the other set screw on that dial, and tighten it firmly as well. Repeat the same procedure for the right dial, but using 100 on the logging scale this time.

That's all! After the dial calibration procedure, check on other bands: if dial



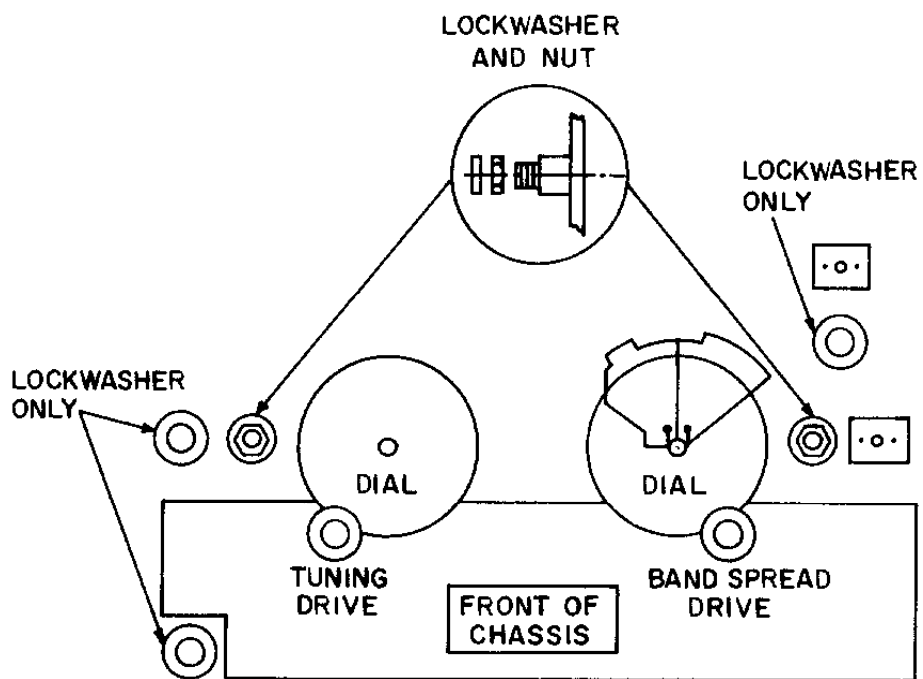

HARDWARE FOR MOUNTING CONTROLS - WHEN PANEL IS REMOVED

STEP 7

