

**installation and  
operating instructions**

---

**for model SX-71  
NBFM and AM  
radio receiver**



**the hallicrafters co.**

MANUFACTURERS OF RADIO AND ELECTRONIC EQUIPMENT. CHICAGO 24, U. S. A.

---

# INSTALLATION AND OPERATING INSTRUCTIONS

## RADIO RECEIVER MODEL SX-71

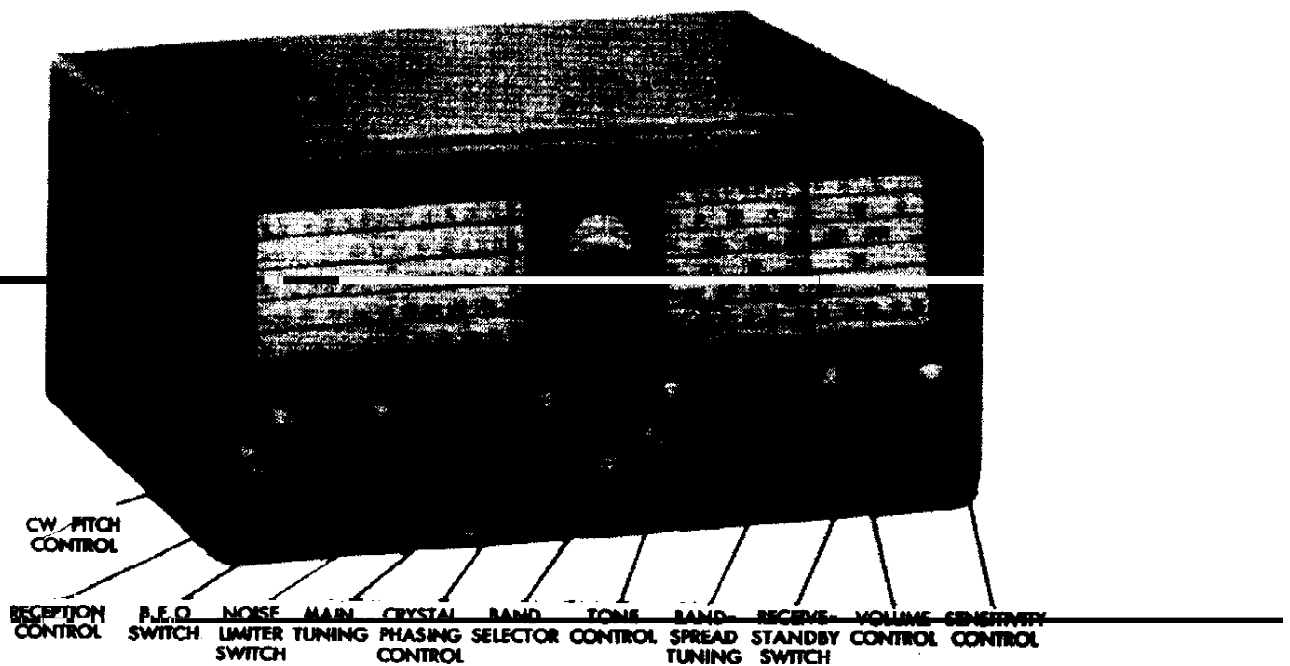

Fig. 1. Radio Receiver Model SX-71

### DESCRIPTION

The Model SX-71 radio receiver is a sensitive communications type superheterodyne receiver covering the 160, 80, 40, 20, 10 and 6 meter amateur bands in its frequency range of 560 kilocycles (KC) to 56 megacycles (MC). The receiver is designed for reception of CW (Code) signals, narrow band frequency modulated (NBFM) signals and amplitude modulated (AM) broadcasts over its entire frequency range as follows:

#### FREQUENCY COVERAGE

Band	# Frequency Range	Type of Reception
1	560 KC - 1600 KC	AM/NBFM/CW
2	1650 KC - 4700 KC	AM/NBFM/CW
3	4.7 MC - 13.4 MC	AM/NBFM/CW
4	12.8 MC - 34 MC	AM/NBFM/CW
5	46 MC - 56 MC	AM/NBFM/CW

AM - Amplitude Modulation  
 CW - Code

NBFM - Narrow Band Frequency Modulation  
 # First and last dial calibration

For maximum ease and flexibility of operation, two extra-wide slide-rule dials calibrated directly in frequency of reception are used. One provides for general coverage over the frequency range 560 KC to 34 MC, and the other is a bandspread dial calibrated specifically for the 80, 40, 20, 10 and 6 meter amateur bands.

The use of a double conversion circuit, improves selectivity and provides better image rejection than in the conventional superheterodyne receiver.

For the ultimate in selectivity, a variable crystal filter and a crystal phasing control are used so that the receiver can be peak adjusted for that hard-to-read signal.

The audio system provides sufficient audio power to operate either headphones or speaker. A phono jack permits operation of the audio amplifier as a separate unit.

An automatic noise limiter operated by a toggle switch, permits the operator to reduce the background noise caused by severe electrical disturbances.

A RECEIVE-STANDBY switch permits receiver disabling for short standby periods without having to wait for the tube heaters to reach operating temperature when reception is again required.

The receiver normally operates from a 105-125 volt 50/60 cycle alternating current (AC) source. A connector for operating the receiver with external batteries or equivalent power is provided to permit operation in areas where AC current does not exist. A universal model of the SX-71 receiver permits operation from 25/60 cycle alternating current sources and at voltages ranging from 105 to 250 volts. The power requirements for your receiver must be checked carefully. Read over the installation section of this book and check the labels on the receiver before connecting to your power source.

## INSTALLATION

**UNPACKING** - Check all shipping instruction tags carefully before removing them.

**LOCATION** - The receiver is equipped with rubber feet for table top or shelf mounting. It is important that the receiver have proper ventilation because overheating may cause excessive frequency drift. Therefore, avoid placing the receiver in excessively warm locations such as near radiators, hot air registers, or confined dead air spaces such as are encountered in recessed installations. Note also that the top cover of the receiver is made of perforated metal to provide proper ventilation of the chassis. Do not block free circulation of air by placing loudspeaker, log book, clocks, etc. on this cover.

This receiver has an extremely high degree of IF selectivity. For this reason it is best to locate the loudspeaker 12" to 18" from the receiver to avoid the possibility of acoustical or mechanical coupling between the two, a condition which would be evidenced by howl or feedback at the higher volume levels.

**POWER SOURCE** - Two types of power sources may be used to operate the receiver. The receiver may be operated directly from an AC source or indirectly from a battery or DC source as follows:

**AC Operation** - The receiver, as normally supplied, operates from a 105 to 125 volt, 50/60 cycle AC outlet. Power consumption is approximately 90 watts. If you are in doubt or unfamiliar with the voltage and frequency rating of your utility service, consult your local power company representative. Attempting to operate the receiver from other sources of power than specified may involve costly repairs.

A universal model is available for operation from 115 V./130 V./150 V./220 V./250 V. 25/60 cycle AC sources. A selector switch on the power transformer permits operation on any of the line voltages shown.

**CAUTION** - When operating the universal model, it is essential to check, and if necessary, to set the selector switch on the power transformer before connecting the receiver to the source of power.

**Note** - The receiver will not operate from an AC source unless the jumper plug is inserted in its BATTERY POWER receptacle. (See Fig. 3.).

**DC Operation** - The receiver may be operated from a 6-volt DC source (storage battery or equal) and a 270-volt DC supply in the form of "B" batteries, vibrator power pack, or motor generator set. The DC source must be capable of supplying the following voltages and currents for optimum results.

"B" voltage .....	270 Volts
"B" current .....	110 Milliamperes
Heater voltage .....	6.3 Volts
Heater current .....	4.4 Amperes

Total current drain, when operating entirely from a storage battery (Vibrator type supply), will run approximately 15 amperes.

DC power is connected to the receiver through the octal socket located on the rear apron of the chassis. The jumper plug normally in this socket for AC operation is replaced with a standard octal plug for DC operation.

Wire the octal plug for DC operation as shown in Fig. 2.

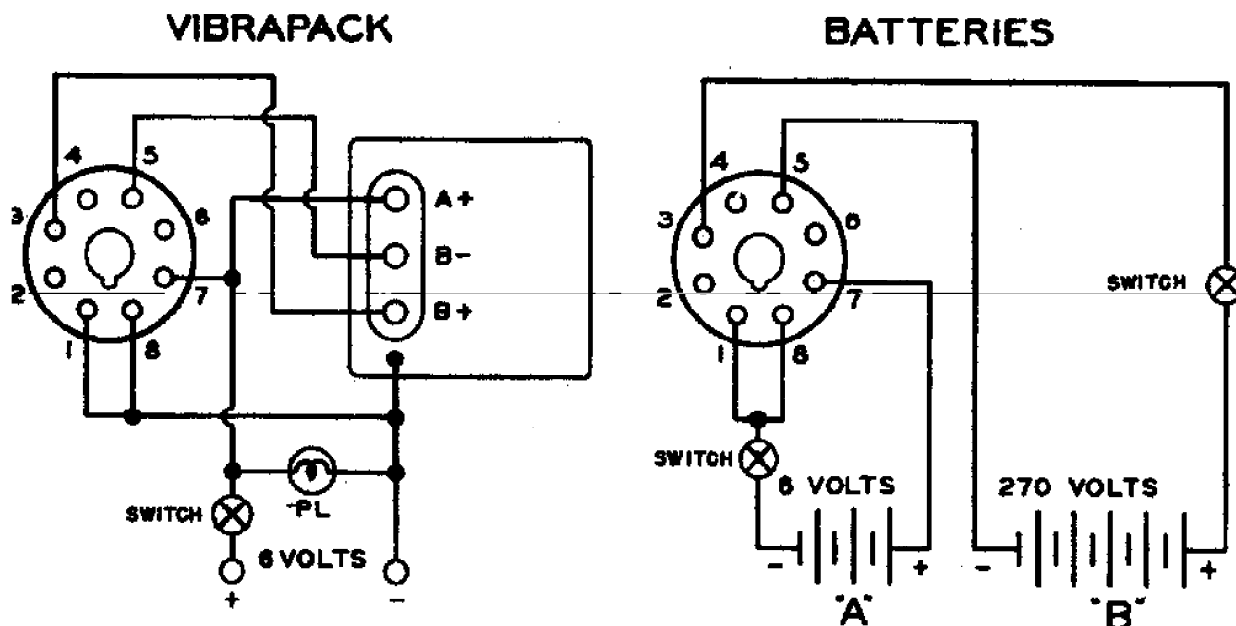

Fig. 2. Wiring diagram, DC power plug.

928800

**SPEAKER CONNECTION** - Three screw type terminals, located on the rear chassis apron, are provided for the speaker connections. The output impedances available are 3.2 and 500 ohms. Any suitable speaker unit which will operate with either of these output impedances may be used with the Model SX-71 receiver.

**ANTENNA** - A three terminal strip marked "A1", "A2" and "G" is located at the rear chassis apron for antenna connections. This terminal arrangement will accommodate either a single wire antenna lead-in or an antenna transmission line.

**Single Wire Antenna** - For a single wire antenna installation, connect a jumper between the antenna terminals "A2" and "G". A single wire antenna about 50 to 100 feet long (including lead-in) is then connected to terminal "A1". Erect the antenna as high and free from surrounding objects as possible. This type of antenna must be well insulated from ground for best results. It may be desirable in some installations to connect a ground wire between terminal "G" and a suitable ground such as a water pipe or outside ground stake.

**Doublet Antenna** - The doublet antenna is recommended for the high frequency bands, especially where a maximum signal to noise level is required over a relatively narrow range of frequencies. The antenna transmission line is connected to terminals "A1" and "A2". If a concentric line with a grounded outer conductor is used, connect the inner conductor to terminal "A1" and outer conductor to terminal "A2", and connect a jumper wire between terminals "A2" and "G".

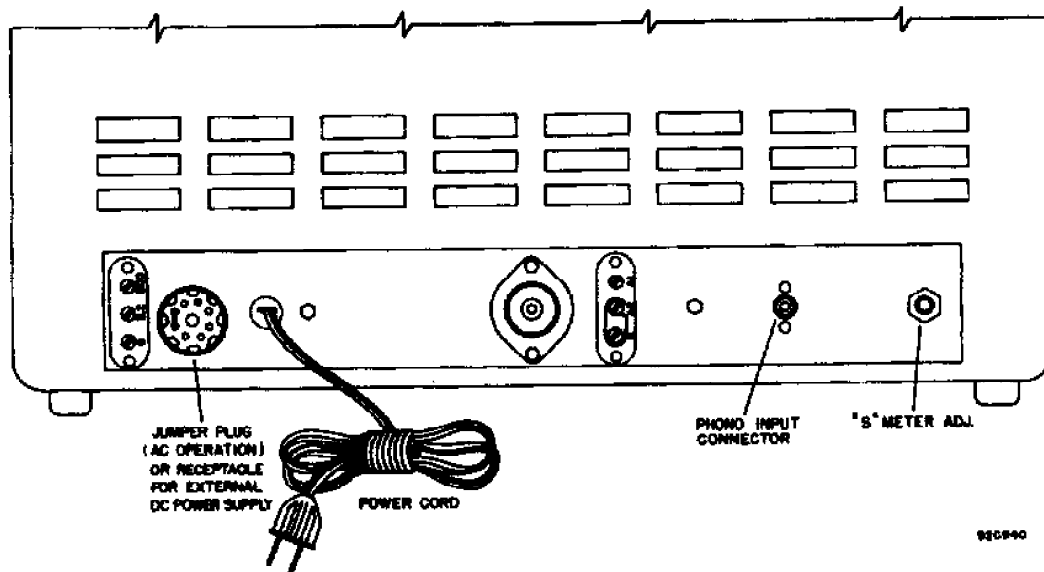
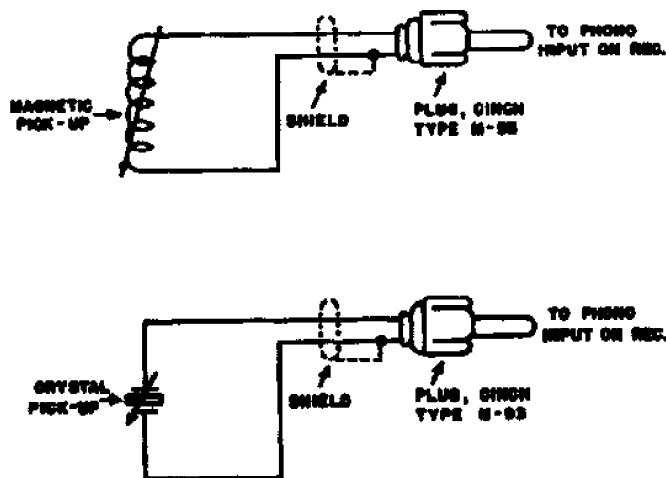

Fig. 3. Rear view.

The overall length (feet) of a doublet antenna may be determined by dividing the constant 468 by the desired frequency in megacycles. Keep in mind that this type of antenna is directional broadside to its length and should be so oriented if maximum pickup from a given direction is desired.

~~This receiver will work satisfactorily with antennas exhibiting impedances ranging from 50 to 600 ohms. However, best performance will be obtained when a 300-ohm antenna is employed. Since every impedance is~~  
 impossible for us to make specific antenna recommendations. However, an excellent source of information on the various types of antennas and problems relating to antenna installation is the American Radio Relay League (West Hartford, Conn.) Radio Amateur's Handbook.

**RECORD PLAYER CONNECTION** - A shielded type receptacle is provided at the rear chassis apron to accommodate a record player pickup cable connector. Any record player employing a crystal cartridge or high level magnetic pickup in its tone arm may be used with the receiver. Refer to Fig. 4 for wiring details.



92B522

Fig. 4. Wiring diagram, record player connection.

**REMOTE STANDBY SWITCH CONNECTIONS** - The receiver may be disabled remotely by connecting a remote switch between pins #4 and #1 of the jumper plug (Fig. 3). To operate the receiver remotely, set the RECEIVE-STANDBY switch on the receiver panel at STANDBY and close the remote switch to put the receiver in operation. Pin #2 of the jumper plug is connected to the free terminal of the SPDT standby switch, (the arm of the switch is grounded in the receiver) and may be used to operate a transmitter relay circuit from the panel of the receiver. In the STANDBY position pin #2 is grounded; in the RECEIVE position pin #2 is insulated from ground.

## OPERATION

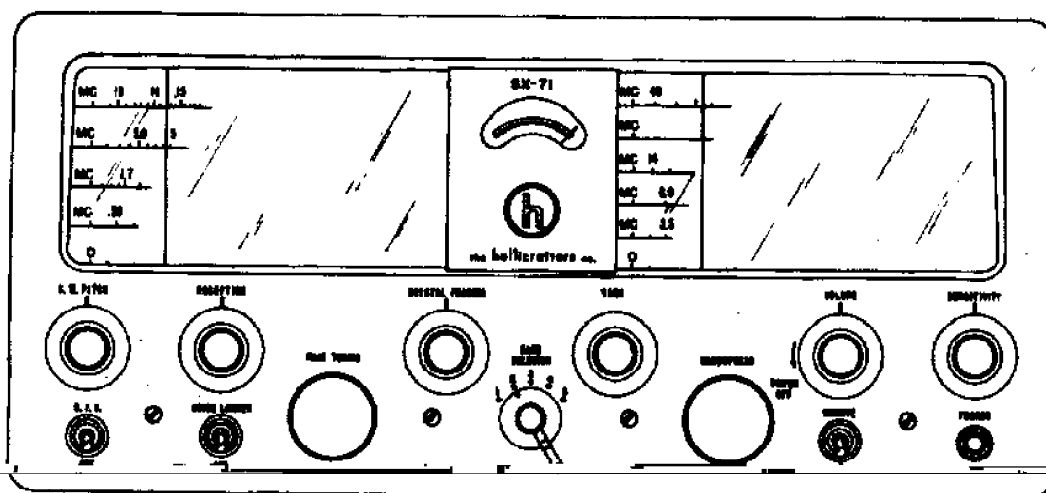

Fig. 5. Front view, location of controls.

**RADIO TELEPHONE RECEPTION** - To receive amplitude modulated (AM) or narrow band frequency modulated (NBFM) radio telephone signals, the following use of the controls is recommended to obtain maximum performance from the MODEL SX-71 receiver.

- VOLUME control** - This control turns the receiver on and off in addition to controlling the volume. Turn the control clockwise to turn on the receiver or increase volume and counter-clockwise to reduce volume. To turn off the receiver, turn the control completely to the left.
- RECEIVE/STANDBY switch** - Normally set at RECEIVE. May be set at STANDBY to disable the receiver for short standby periods and yet keep the tube heaters at operating temperature for instant use.
- B.F.O. switch** - For radio phone reception, this control is set at OFF.
- RECEPTION control** - Set at N.B.F.M. for the reception of narrow band frequency modulated radio telephone stations located in any of the short wave bands. To receive amplitude modulated radio telephone signals over any portion of the frequency range, three positions of the RECEPTION control may be used; these are, NORMAL I.F., BROAD CRYSTAL, and SHARP CRYSTAL. The individual settings will be determined by the degree of selectivity desired; the broadest bandwidth is under NORMAL I.F. and the narrowest, under SHARP CRYSTAL. The use of the crystal filter will require an adjustment of the CRYSTAL PHASING control. Refer to "USE OF CRYSTAL PHASING CONTROL" for details.

- BAND SELECTOR control** Set for the desired position as indicated by the band number on the dial scale. Bands 1 through 4 are found on the left hand or main tuning dial and band 5 is on the right hand or bandspread dial.
- MAIN TUNING control** Sets the frequency of reception on bands 1 through 4 after the individual band has been selected by the BAND SELECTOR. Frequencies of all bands are shown in megacycles (MC).
- BANDSPREAD control** Sets the frequency of reception on band 5 after the band has been selected by the BAND SELECTOR. The calibration of the band 5 dial scale will be true only when the main tuning dial pointer is set at "100" on the main tuning logging scale.
- IMPORTANT** - The calibrations on the main tuning dial scales will be true only when the bandspread dial pointer is set at "100" on the bandspread logging scale.
- More specifically, however, the BANDSPREAD control functions to spread out the amateur and shortwave bands.
- Amateur band reception - To use the BANDSPREAD control on the amateur bands, first set the bandspread dial pointer at "100" on the bandspread logging scale. Index the MAIN TUNING control for any of the amateur bands as indicated by the white dots on the main tuning dial and then tune through the band with the BANDSPREAD control.
- Short Wave reception - To tune the shortwave broadcast stations with the BANDSPREAD control; set the bandspread dial pointer at "100"; set the main tuning dial pointer slightly higher in frequency than the desired group of short wave stations and then tune in the stations with the BANDSPREAD control. Note that the frequency of reception cannot be read directly from either set of dial scales for general short wave reception. However, short wave stations may be logged by recording the two dial pointer settings with the logging scales.
- 
- SENSITIVITY control** Normally set maximum clockwise. The control must be set maximum clockwise for correct "S" meter operation.
- 
- TONE control** Set at 10 for normal response. Turn in a counter-clockwise direction to attenuate the high frequency audio response.
- NOISE LIMITER Switch -** Normally set at "OFF". Where natural or "man-made" static interferes with reception this switch may be set at NOISE LIMITER to reduce the interference. See Fig. 6.
- CW (Code) RECEPTION** - To receive code transmissions the following use of the receiver controls is recommended:
- B.F.O. switch -** Set at B.F.O. for CW reception.
- C.W. PITCH control -** After the code signal has been tuned in, this control can be adjusted to the tone pitch that is most pleasing to the ear of the operator.

- VOLUME control** - Same as for RADIO TELEPHONE RECEPTION.
- RECEIVE/STANDBY switch** - Same as for RADIO TELEPHONE RECEPTION
- BAND SELECTOR control** - Same as for RADIO TELEPHONE RECEPTION.
- MAIN TUNING control** - Same as for RADIO TELEPHONE RECEPTION.
- BANDSPREAD control** - Same as for RADIO TELEPHONE RECEPTION
- RECEPTION control** - Set for NORMAL I.F. If a greater selectivity is desired, this control should be set for BROAD CRYSTAL or SHARP CRYSTAL. The use of the crystal filter will require an adjustment of the CRYSTAL PHASING control. Refer to "USE OF CRYSTAL PHASING CONTROL" for details.
- 
- ~~**TONE control** - Set at 0 for code reception~~
- SENSITIVITY control** - The receiver sensitivity must be controlled manually for code reception, hence the SENSITIVITY control must be advanced just enough to keep the code stations from blocking the receiver.
- NOISE LIMITER switch** - The noise limiter circuit is particularly useful for code reception because it "clips" the intermittent noise peaks down to the level of the desired signal where they tend to become unnoticeable. See Fig. 6, for an illustration of limiter action.

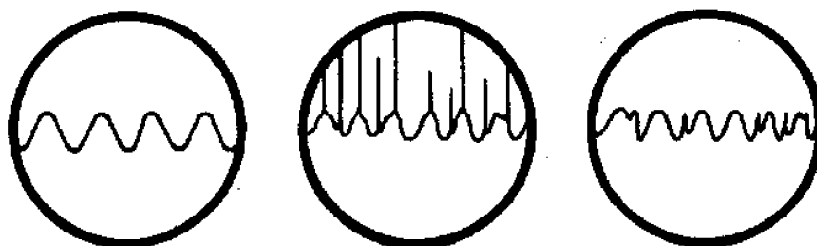
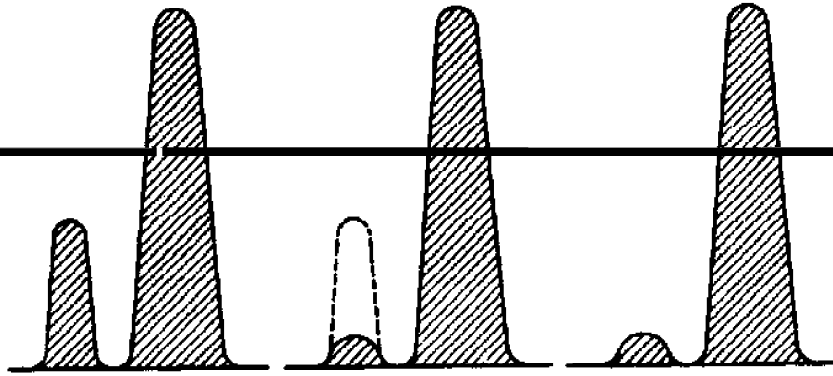

Fig. 6. Noise limiter action.

92X872

**USE OF CRYSTAL PHASING CONTROL** - This control permits the discrimination of interfering signals whose frequencies are very near the desired signal. To attain single signal reception with the SX-71, first set the RECEPTION switch to either BROAD CRYSTAL or SHARP CRYSTAL. Choose a strong signal, preferably a commercial station because a commercial is likely to stay on long enough for you to complete the phasing adjustment for single signal reception.

You will find on tuning across this signal that it has two amplitudes. Now turn the CRYSTAL PHASING control until the weaker of the two amplitudes is reduced to a minimum. Then, tune to the stronger of the two amplitudes and adjust the PITCH control (for c-w reception) to a tone most pleasing to you. This adjustment for single signal selectivity will require no further adjustment unless you change the phasing control. See Fig. 7, for an illustration of single signal operation.



2EX974

Fig. 7. Single signal operation.

**USE OF THE "S" METER** - The "S" meter or tuning meter functions when the receiver is set up for amplitude modulated radio telephone reception and provides a means for setting the receiver "dead on" the carrier frequency and gives a relative reading of received signal strength. A true "S" meter reading is obtained only when the SENSITIVITY control is set for maximum sensitivity (max. clockwise rotation) and the receiver is tuned for the maximum meter reading.

The meter circuit is disabled for code or narrow band FM reception.

**NOTES ON NBFM RECEPTION** - When tuning in amateur radiophone stations using narrow band frequency modulation, tune for minimum distortion. Note that in general, the headset or speaker volume is slightly less than for AM phone reception. This is normal. However, when the volume level is very low, it indicates that the deviation of the FM signal is considerably below  $\pm 2\text{-}1/2$  KC. When the received signal is loud and very distorted, the transmitted signal has a deviation in excess of  $\pm 2\text{-}1/2$  KC. In ex-

reception and tuning off to one side of the transmitted carrier as is customary with of FM are not available. The SX-71 receiver has been designed to provide optimum results when receiving FM signals having a maximum of  $\pm 2\ 1/2$  KC deviation. It should also be noted that when the receiver is switched to NBFM, the "S" meter is rendered inoperative.

**RECORD PLAYER OPERATION** - With a record player connected to the receiver it is merely necessary to set the RECEPTION control at PHONO and operate the VOLUME and TONE controls as for normal radio reception.

**CAUTION** - The receiver will not respond if the RECEIVE/STANDBY switch is set at STANDBY. The setting of the remaining controls, except those mentioned above, is immaterial as they are not in use for record player operation.

**HEADPHONE OPERATION** - A headset jack located on the front panel, provides for headphone reception. Insertion of the headset plug disables the speaker. Any standard headset of low or medium impedance can be used with this receiver.

The Hallicrafters Co. reserves the privilege of making revisions in current production of equipment and assumes no obligation to incorporate these revisions in earlier models.

## SERVICE

**TUBE REPLACEMENT** - The types of tubes required and their relative position in the receiver are shown in the illustration, Fig. 8. When installing a replacement tube, insert the center guide pin into the center hole of the tube socket; rotate the tube until the key on the guide pin drops into the notch in the socket hole; push down until the base of the tube rests firmly on the socket. A slightly different technique must be used on the miniature tubes. They have seven small pins which have to be lined up with the socket holes before pushing into place. Handle with care as all tubes are considered fragile and do not tolerate much mechanical abuse.

~~CLEANING AND REPAIRING OF DIAL GLASS~~ - To clean or replace the dial glass, it will be necessary to remove the front panel from the chassis to gain access to the glass. To do this, first remove all knobs and hex nuts holding the potentiometers and jacks to the panel. Then remove the four screws from the front of the panel and the screws on the side and bottom. The front panel can then be removed from the chassis.

**SERVICE OR OPERATING QUESTIONS** - Factory type service is available at Hallicrafters Authorized Field Service Centers. For Warranty Service information or further details regarding operation or servicing of the receiver in general, contact the dealer directly. Make no service shipments directly to the factory before first writing for authorization and instructions. The factory cannot accept responsibility for unauthorized shipments.

**SERVICE LITERATURE** - If a service manual was not packed with this receiver, advise the Hallicrafters Company on the guarantee card and one will be forwarded.

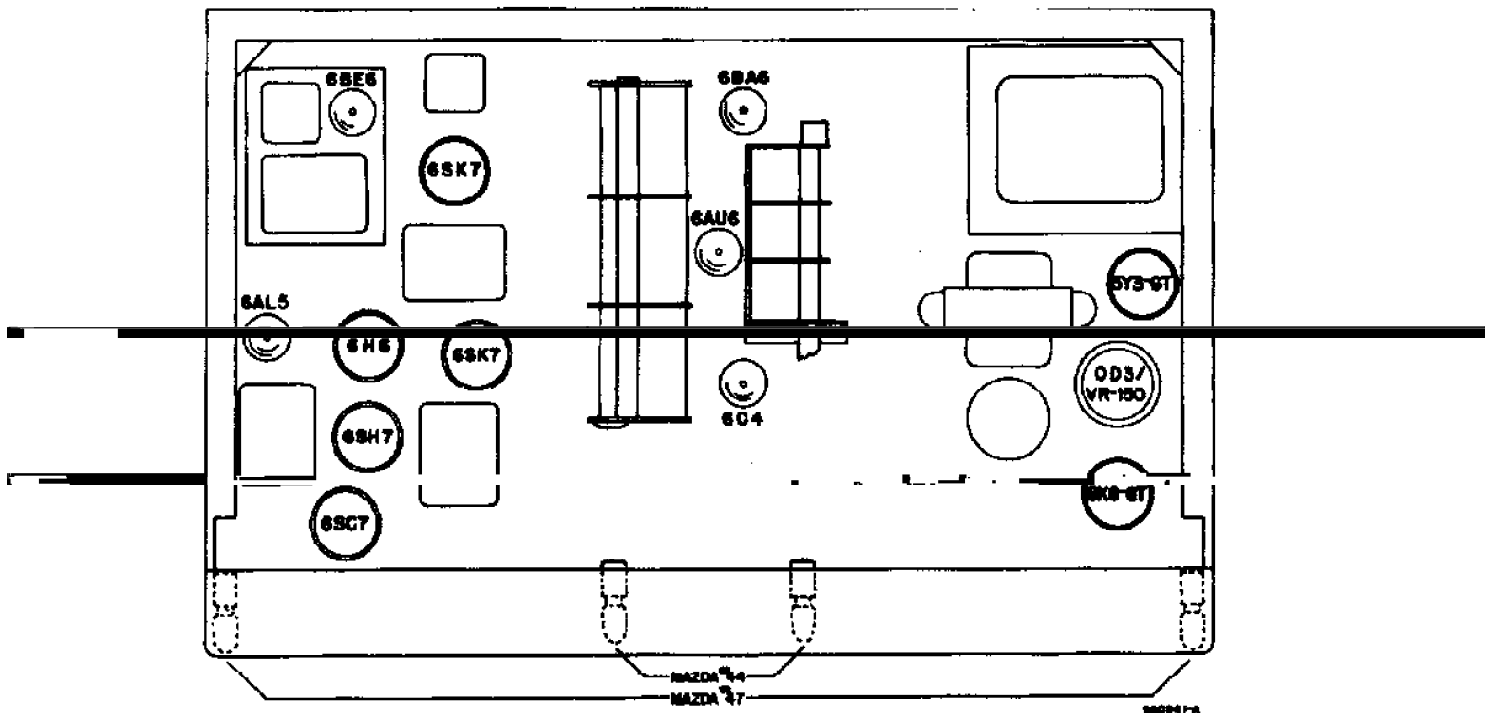

Fig. 8. Top view showing location of tubes and dial lamps.

**DIAL LAMP REPLACEMENT** - Refer to Fig. 8 for the location of the dial lamps in the receiver. Access to defective lamps, may be gained through the top cabinet cover. The two end lamps are fastened by screws to an angle bracket. Remove the screws and change the lamp using a 6-8 V. Mazda #47 (brown bead) or equivalent. To change the two dial lamps in the center, it is necessary to unscrew the two screws holding the sockets in place. These two lamps should be replaced with 6-8 V. Mazda #44 (blue bead) or equivalent.

# the hallicrafters co.

## SERVICE BULLETIN FOR MODEL SX-71

### GENERAL

Tubes . . . . . eleven plus voltage regulator and rectifier  
Speaker Output . . . . . 3.2/500 ohms  
Headset Output . . . . . 500 ohms  
Antenna Input . . . . . For 50 to 600 ohm line or single wire lead-in.  
Phono Input . . . . . High impedance  
External Power Connector . . . . . Std. octal socket

#### TUNING RANGE

Band	*Frequency Range	Type of Reception	Intermediate Frequency
1	560 KC - 1600 KC	AM/NBFM/CW	455 kc
2	1650 KC - 4700 KC	AM/NBFM/CW	455 kc
3	4.7 MC - 13.4 MC	AM/NBFM/CW	2.075 mc and 455 kc
4	12.8 MC - 34 MC	AM/NBFM/CW	2.075 mc and 455 kc
5	46 MC - 59 MC	AM/NBFM/CW	2.075 mc and 455 kc

\* First and last dial calibration

Power Supply . . . . . Standard Model 105-125 V. 60 Cycles AC  
Universal Model 105-250 V. 25/150 Cycles AC  
Power Consumption . . . . . 90 Watts.

### RESTRINGING DIAL CORD

The dial drive system of the SX-71 consists of four separate spring drives. The two drive shaft string systems are identical; the two pointer drive systems are similar but right and left handed.

(1) DRIVE SHAFT. - To restring either one, use a 28 inch length of 30 lb. test dial cord. Tie one end of the cord to position "1" on the drum and follow the stringing sequence "1" to "9" as shown. At position "9" stretch the tension spring and tie the cord securely to the spring. Note that the dial cord is wrapped around the drive shaft three and one half times for proper traction.

(2) POINTER DRIVE - To restring either one, use a 66 inch length of 30 lb. test dial cord. Tie one end of the dial cord to position "A" and follow the stringing sequence "A" to "U" as shown. At position "U", stretch the tension spring and tie the cord securely to the spring. Two small pieces of spaghetti tubing approximately one half inch long should be threaded on

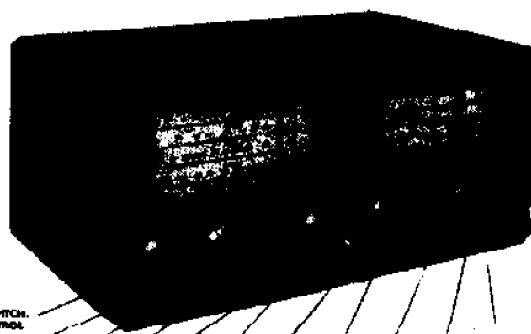

CW HIGH CONTROL  
RECEPTION CONTROL  
S.F.D. SWITCH  
NOISE LIMITER SWITCH  
MAIN TUNING  
CRYSTAL PHASING CONTROL  
BAND SELECTOR  
TONE CONTROL  
BAND SPREAD TUNING  
RECEIVE STANDBY SWITCH  
VOLUME CONTROL  
SENSITIVITY CONTROL

the cord, as shown, to provide a suitable purchase for the dial pointer. With the pointer drive, pulleys positioned as shown on the diagram (Fig. 1), the tuning capacitor should be entirely closed. The pointer may now be fastened to the cord and aligned with the 0 position on the logging scale and the index marks on the dial scales. The ends of the pointer should be carefully crimped around the spaghetti tubing and cemented fast.

### REPLACING LAMPS

Refer to Fig. 8 for the location of the dial lamps in the receiver. To gain access to the defective lamps, remove the chassis from the cabinet by removing the screws on the sides and bottom. The two end lamps are fastened by screws to an angle bracket. Remove the screws and change the lamp using a type Mazda #47 (brown bead) or equivalent. To change the two dial lamps in the center, remove the screws holding the sockets in place and replace the lamps using a type Mazda #44 (blue bead) or equivalent.

### "S" METER ADJUSTMENT

#### MECHANICAL:

Turn off the receiver.

Immediately below the dial face of the "S" meter is a round metal disc. This disc is pivoted so that it may be moved to one side. Doing this discloses the pivot adjustment screw of the "S" meter. Use a screw driver and carefully rotate the screw in either direction until the needle indicates zero.

#### ELECTRICAL ADJUSTMENT:

Turn the receiver on.

Set the RECEIVE STANDBY switch at RECEIVE.

Set BFO at OFF.

Set the SENSITIVITY CONTROL at MAXIMUM.

Set the NOISE-LIMITER at OFF.

Short the antenna terminals to ground.

The "S" meter adjustment control is located on the left rear apron of the chassis. Turn this control slowly until the needle in the "S" meter indicates zero.

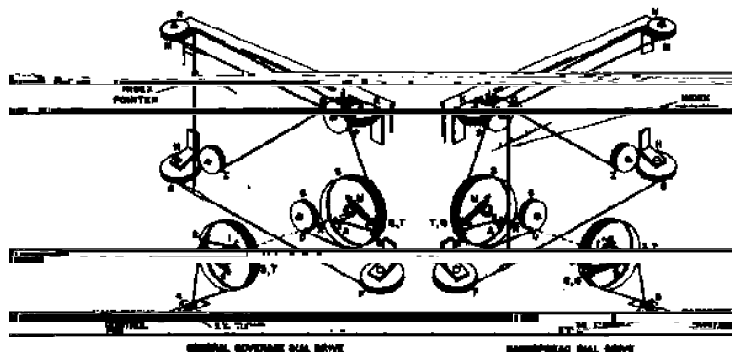

Figure 1. Dial cable stringing procedure



### ALIGNMENT PROCEDURE

It will be necessary to remove the receiver chassis from the cabinet to make all alignment adjustments. The chassis is held in the cabinet by two screws on the bottom rear and by the flanges on the side and bottom. The following control settings are to be set before alignment: TONE control at maximum. SENSITIVITY control at maximum. VOLUME control at maximum. NOISE LIMITER switch at OFF. RECEIVE/STANDBY switch at RECEIVE.

#### I-F ALIGNMENT

Step	Signal Gen. Coupling	Signal Gen. Frequency	Receiver Control Settings	Receiver Dial Set	Adjust	Remarks
1	of gang, mixer sect.	Unmodulated	RECEPTION switch at BROAD CRYSTAL. BFO switch at BFO.	set at 50 on the logging scale		for zero beat. Replace knob with the zero at the index line.
2	Same as step 1.	Same as step 1.	Adjust C.W. BFO for a 1000 cycle note. Other controls same as step 1.	Same as step 1.	X	With tuning the slow scan slowly in one direction, "rock" the signal generator. As the adjustment passes thru the response of the crystal filter, the output goes thru a maximum, dips down, and starts going up again. The correct setting of this slug is in the center of the observed dip. A swishing note, in contrast to the sharp crystal tone will be apparent when the correct adjustment has been reached.
3	Same as step 1.	Same as step 1.	RECEPTION switch at SHARP CRYSTAL. Other controls same as step 1.	Same as step 1.		Set the generator frequency for maximum output on the crystal frequency.
4	Same as step 1.	Same as step 3. Modulated	RECEPTION switch at NORMAL I.F. BFO switch at OFF. Other controls same as step 1.	Same as step 1.	V W X Y Z (1) (2)	Maximum output Maximum output Maximum output Maximum output Maximum output Maximum output Repeat above until maximum gain is obtained.

#### F-M ALIGNMENT

5	Same as step 1.	Same as step 3. Increase output to approx. 1000 microvolts.	RECEPTION switch at NBFM. Other controls same as step 1.	Same as step 1.	(3)	Set up circuit shown in Fig. 2. Until vacuum tube voltmeter shows zero voltage.
---	-----------------	---	--	-----------------	-----	---

#### I-F ALIGNMENT

6	Same as step 1.	2.075 MC Modulated	RECEPTION switch at NORMAL I.F. BAND SELECTOR at 4.	Same as step 1.	(4) (5) (6)	Until a signal is heard. For maximum output. For maximum output. Repeat until the maximum output is obtained.
---	-----------------	--------------------	---	-----------------	-------------------	--

#### R-F ALIGNMENT

Leave BANDSPREAD dial at 100 for all steps. The following adjustments can be made without removing the chassis from the cabinet.

1	Connect the high side of the gen. thru a 300 ohm resistor to term. A1 of the ant. term. strip. Connect a jumper between A2 & C. Use just enough gain to obtain a 500 milliwatt audio output level.	1500 KC 600 KC 1500 KC	BAND SELECTOR at 1. RECEPTION switch at NORMAL I.F. BFO switch at BFO	1500 KC 600 KC 1500 KC	A(osc.trim) B C D(osc.pad) A B	Until a signal is heard. For maximum output. For maximum output. Until a signal is heard. For maximum output. For maximum output. Repeat until maximum output is obtained.
2	Same as step 1.	4 MC	BAND SELECTOR at 2. Other controls as in step 1.	4 MC	E(osc.trim) F G E F G	Until a signal is heard. For maximum output For maximum output For maximum output For maximum output For maximum output Repeat until maximum output is obtained.
3	Same as step 1.	12 MC 5.2 MC 12 MC	BAND SELECTOR at 3. Other controls as in step 1.	12 MC 5.2 MC 12 MC	H(osc.trim) I H J K	Until a signal is heard Until a signal is heard For maximum output. ("Rock" the gang) For maximum output. ("Rock" the gang) For maximum output. ("Rock" the gang) Repeat until maximum results are obtained.
4	Same as step 1.	30 MC 14 MC	BAND SELECTOR at 4. Other controls as in step 1.	30 MC 14 MC	L(osc.trim) M (slug) N O L P Q	Until a signal is heard. Until a signal is heard. For maximum output. ("Rock" the gang) For maximum output. ("Rock" the gang) For maximum output. ("Rock" the gang) For maximum output. ("Rock" the gang) For maximum output. ("Rock" the gang) Repeat until maximum results are obtained.
5	Same as step 1.	54 MC	BAND SELECTOR at 5. Other controls as in step 1.	100 on logging scale.	R(osc.trim) S T	Until a signal is heard. For maximum output. ("Rock" the gang) For maximum output. ("Rock" the gang) Repeat until maximum results are obtained.

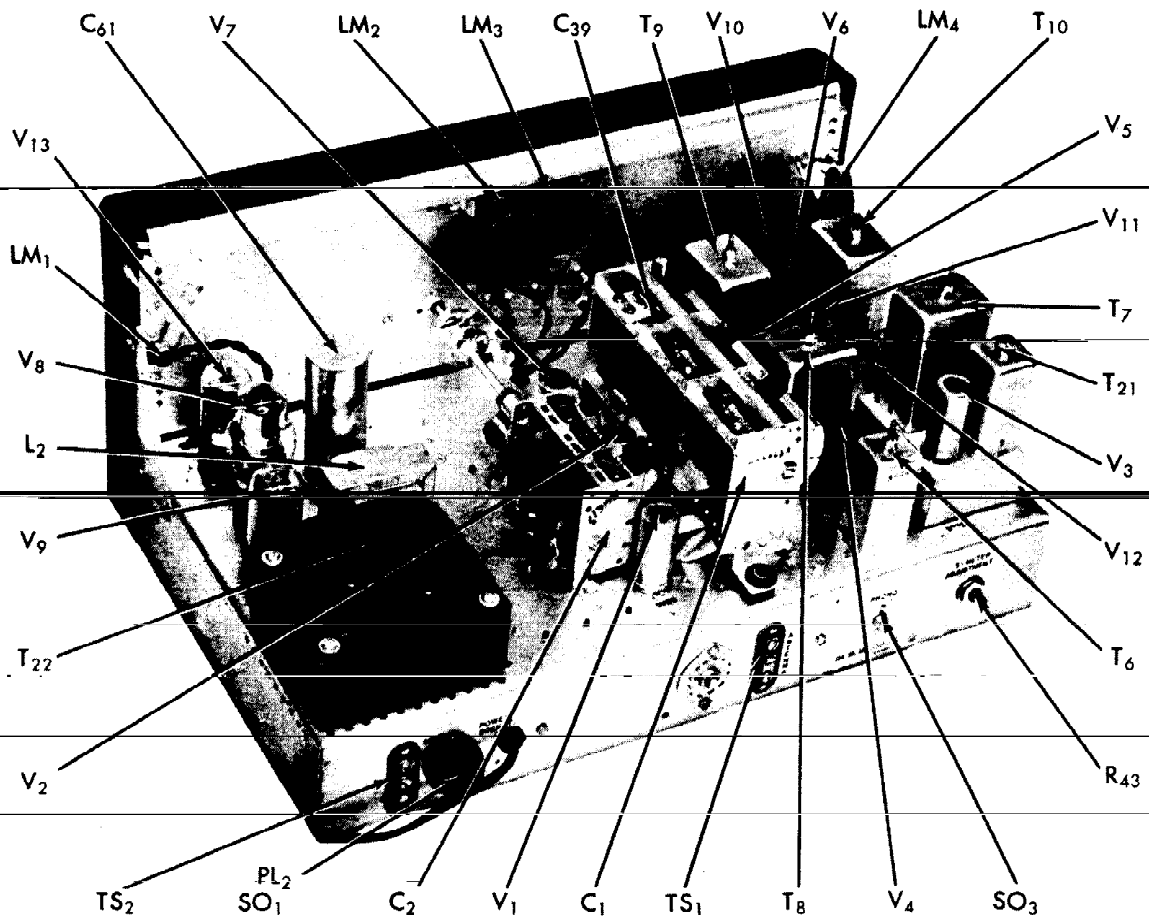

Fig. 5. Component locations, top view

92X966

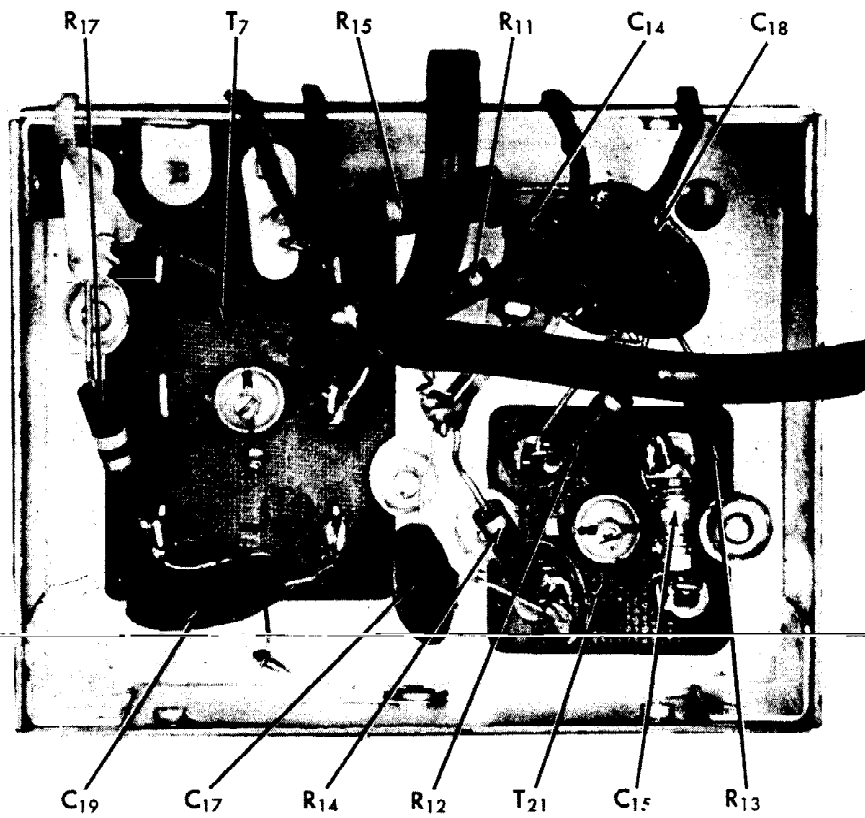

Fig. 6. Component locations, bottom view second converter unit

92X1075

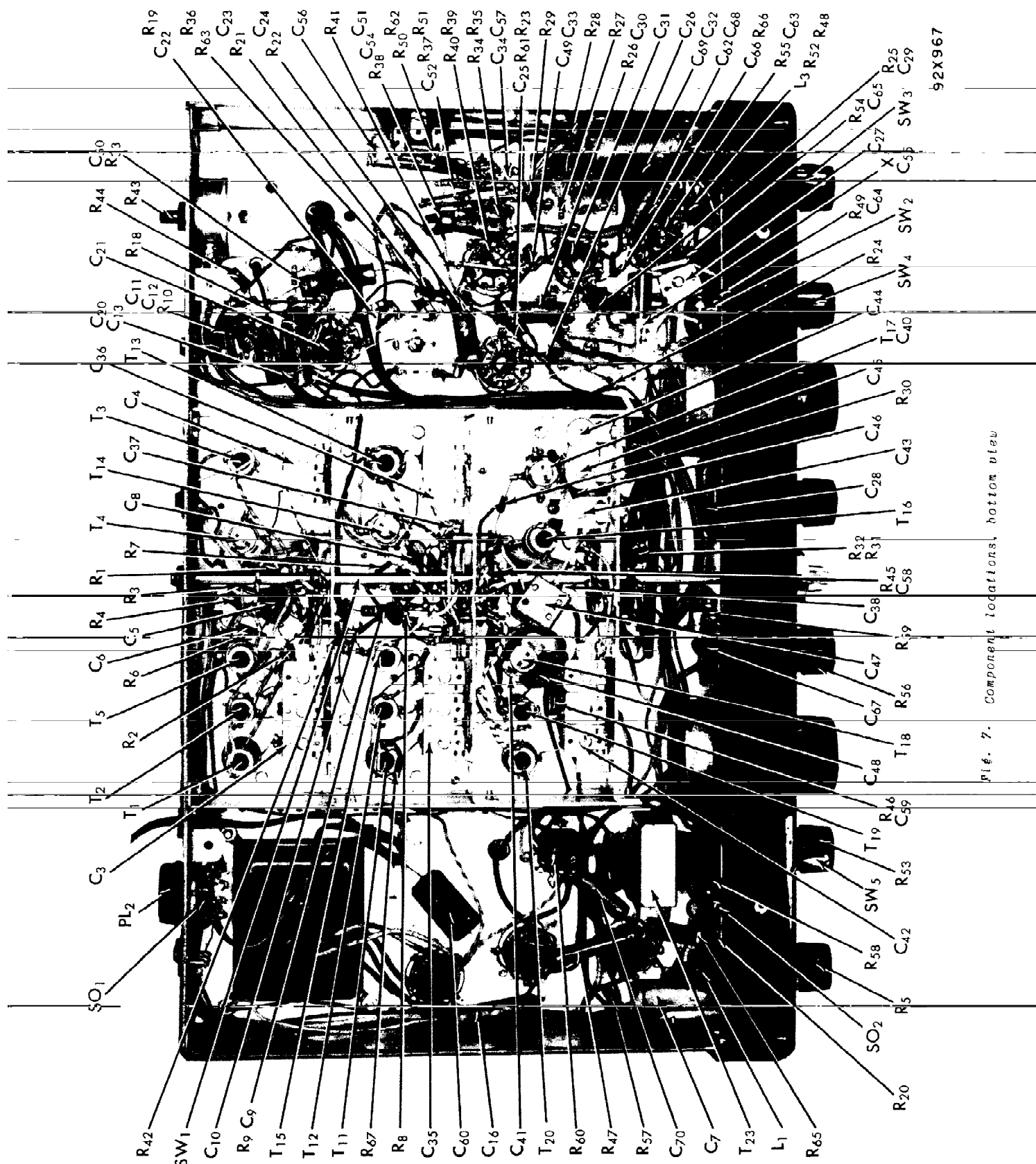

Fig. 7. Component locations, bottom view

92X967

- SO1
- PL2
- C3
- T1
- T2
- T5
- R2
- R6
- C6
- R4
- R1
- T4
- T14
- T3
- C36
- C20
- C21
- R44
- R43
- C11
- R18
- C12
- R10
- R19
- C22
- R36
- R63
- C23
- R21
- C24
- R22
- C56
- R41
- C51
- R38
- C54
- R62
- R50
- R51
- C52
- R37
- R40
- R39
- R34
- R35
- C34
- C57
- C25
- R61
- R23
- R29
- C49
- C33
- R28
- R27
- R26
- C30
- C31
- C26
- C69
- C32
- C62
- C68
- C66
- R66
- R55
- C63
- L3
- R52
- R48
- R49
- R54
- C64
- C65
- R24
- C67
- C65
- X
- C44
- R25
- T17
- C40
- SW4
- SW2
- C55
- SW3
- C29
- R32
- R31
- C45
- C46
- C46
- R30
- C28
- C43
- T16
- R32
- R31
- C38
- R45
- C58
- T18
- R56
- R39
- R58
- C42
- R53
- R16
- T19
- R16
- C59
- R5
- R20
- R42
- SW1
- C10
- R9
- C9
- T15
- T12
- T11
- R67
- R8
- C35
- C60
- C16
- C41
- T20
- R60
- R47
- R57
- C70
- C7
- T23
- L1
- R65
- SO2
- R5
- R42
- R53
- R16
- T19
- R16
- C59
- R5
- R20

**PERFORMANCE DATA FOR SERVICE ENGINEERS**

If this receiver is to continue giving the fine performance of which it is capable, only experienced service engineers should repair and realign it. It is essential that the equipment and methods used be comparable with those set forth by the Institute of Radio Engineers in their "Standards of Radio Receivers". The necessary data on receiver performance is given below:

Measurement conditions are as follows unless otherwise specified:  
 Modulation - 30% at 400 cycles - - - Output - 50 milliwatts into 500 ohms.  
 Dummy antenna - Standard IRE on bands 1 & 2, 300 ohms on bands 3, 4, and 5.

**FREQUENCY LIMITS ON EACH BAND**

Band - 1	.538 mc to 1.65 mc	Band - 4	12.5 mc to 35 mc
Band - 2	1.6 mc to 4.6 mc	Band - 5	46.0 mc to 56 mc
Band - 3	4.6 mc to 13.5 mc		

**OVERALL BANDWIDTHS**

At the IF frequency of 2075 kc, bandwidth at 6 DB down is 3.5 kc, at 60 DB - 14 kc.  
 At the IF frequency of 2075 kc. (Broad Xtal) 6 DB down is .7 mc, at 60 DB - 11 kc.  
 At the RF frequency of 1000 kc. (Reception Normal) bandwidth at 6 DB down is 3.2 kc and at 60 DB down is 13 kc.

**AUDIO RESPONSE**

Plus or minus 5 DB from 100 to 3000 cycles.

**IF AMPLIFIER GAIN (455 kc) AND BANDWIDTH**

	Modulator Stage (Osc working: set tuned to 3 mc)	1st IF Amplr.	2nd IF Amplr.	3rd IF Amplr.
Gain	15 X	29 X	4.5 X	24 X
At 6 DB down	6 kc	6 kc	6 kc	20 kc
At 20 DB down	15 kc	16 kc	15 kc	125 kc

**NOISE**

For 2 microvolts input, the signal to noise ratio is not less than 10 DB.

GENERAL PERFORMANCE				SINGLE STAGE CHARACTERISTICS			GENERAL PERFORMANCE			SINGLE STAGE CHARACTERISTICS			
Band	MC	uv	Image Ratio	Antenna Gain	RF Gain	Osc (Conv Gain)	Band	MC	uv	Image Ratio	Antenna Gain	RF Gain	Osc (Conv Gain)
1	.600	12	24,000 X	3.4 X	2.9 X	14 X	4	14.0 *	1,500 X	1.3 X	6.0 X	12 X	
	1.000	6.5	7,000 X	3.5 X	3.5 X	15 X		24.0 *	180 X	1.7 X	6.5 X	14 X	
	1.500	3.3	1,300 X	3.6 X	3.5 X	12 X		30.0 1	100 X	1.7 X	8.1 X	9 X	
2	1.0	1.5	20,000 X	4.7 X	3.2 X	18 X	5	48.0 1	36 X	1.8 X	6.6 X	13 X	
	3.2	*	1,000 X	4.9 X	6.1 X	18 X		54.0 *	20 X	1.8 X	7.7 X	18 X	
	4.0	*	300 X	4.7 X	7.2 X	16 X							
3	5.2	2.4	8,000 X	1.9 X	7.1 X	10 X							
	9.0	1.4	2,500 X	2.9 X	7.6 X	12 X							
	12.0	-	970 X	5.5 X	7.7 X	13 X							

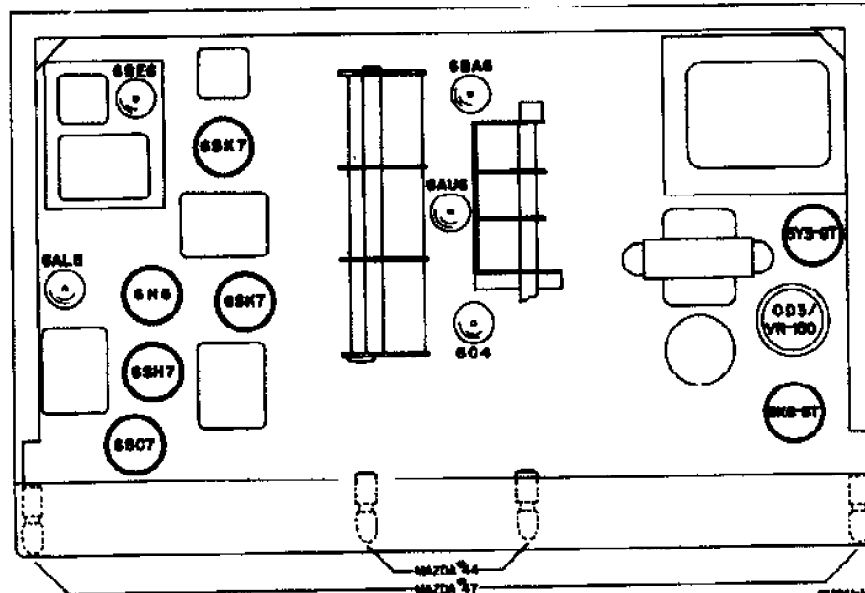

Fig. 9. Top view, location of tubes and dial lamps



## SERVICE PARTS LIST

Ref. No.	Description	Manufacturer's Part Number	Ref. No.	Description	Manufacturer's Part Number
C-1	Capacitor, MAIN TUNING (3 section)	48D209	R-10, 24, 28, 42	3300 ohms 1/2 watt, carbon	23X20X332K
C-2	Capacitor, BANDSPREAD (3 section)	48C210	R-11	220 ohms 1/2 watt, carbon	23X20X221K
C-3	Trimmer Ass'y, antenna stage (Bands 1, 2 & 5)	44B361	R-12, 45	22,000 ohms 1/2 watt, carbon	23X20X223K
C-4	Trimmer Ass'y, antenna stage (Bands 3 & 4)	44B379	R-14, 48	150 ohms 1/2 watt, carbon	23X20X151K
C-5, 33, 34, 53, 57, 63, 68	220 mmf. 500 V., ceramic	47B20221K5	R-15, 46, 60	10,000 ohms 1 watt, carbon	23X30X103K
C-6, 10, 19, 67	2 x 4,000 mmf. 450 V., ceramic	47A218	R-17, 21, 25, 49, 52, 55	100,000 ohms 1/2 watt, carbon	23X20X104K
C-7	.25 mfd. 200 V., tubular	46AT254J	R-18, 26	270 ohms 1/2 watt, carbon	23X20X271K
C-8, 14, 38, 41, 58	100 mmf. 500 V., ceramic	47X20UJ101K	R-19, 27	33,000 ohms 1/2 watt, carbon	23X20X333K
C-9, 12, 17, 18, 21, 22, 23, 25, 26, 31, 64, 75,	5,000 mmf. 450 V., ceramic	47A168	R-20	47,000 ohms 1 watt, carbon	23X30X473K
**C-11, 13	300 mmf. 500 V., mica	47X20B301J	R-22	1000 ohms 1/2 watt, carbon	23X20X102M
C-15	47 mmf. 500 V., ceramic	47X20UK470K	R-23	6800 ohms 1/2 watt, carbon	23X20X682K
C-16, 20, 24, 30, 50	.05 mfd. 600 V., tubular	46AY503J	R-29	56,000 ohms 1/2 watt, carbon	23X20X563K
C-27	Trimmer, adjustable	44A047	R-31	680 ohms 1/2 watt, carbon	23X20X681K
C-28	Capacitor, variable CRYSTAL PHASING	48A182	R-32, 33	2700 ohms 1/2 watt, carbon	23X20X272K
C-29	33 mmf. 500 V., mica	47X20A330K	R-34, 35, 40	470,000 ohms 1/2 watt, carbon	23X20X474K
C-32	.25 mfd. 600 V., tubular	46AX254J	R-36	180,000 ohms 1/2 watt, carbon	23X20X184K
C-35	Trimmer Ass'y, mixer stage (Bands 1, 2 & 5)	44B382	R-37	82,000 ohms 1/2 watt, carbon	23X20X823K
C-36	Trimmer Ass'y, mixer stage (Bands 3 & 4)	44B380	R-38, 50, 59	220,000 ohms 1/2 watt, carbon	23X20X224K
C-37	15 mmf. 500 V., ceramic	47X20UJ150K	R-43	Resistor, variable, 500 ohms, 8-METER ADJUSTMENT	25C022
C-39	2.2 mmf. 450 V., ceramic	47A160-4	R-47	Resistor, 2500 ohms 10 watts, wirewound	24BG252D
C-40, 49	25 mmf. 500 V., ceramic	47X20UK250K	R-51	39,000 ohms 1/2 watt, carbon	23X20X393K
C-42	Trimmer Ass'y, oscillator stage (Bands 1 & 2)	44B383	R-53	Resistor, variable, 500,000 ohms, VOLUME control	25B604
C-43, 44, 45	(Bands 3, 4, & 5)		R-54	15 megohms 1/2 watt, carbon	23X20X156K
**C-46	910 mmf. 500 V., mica	47X30D911J	R-58	Resistor, variable, 500,000 ohms, TONE control	25B589
**C-47	1500 mmf. 500 V., mica	47X30D152G	R-57, 59	560 ohms 1 watt, carbon	23X30X561K
C-51	.1 mfd. 200 V., tubular	46AU104J	R-61, 62	6.8 ohms 1 watt, carbon	23X30X068K
C-54	.02 mfd. 200 V., tubular	46AU203J	R-63	27,000 ohms 1/2 watt, carbon	23X20X273K
C-55	10 mmf. 500 V., ceramic	47X20UK100K	R-65	47,000 ohms 2 watts, carbon	23X40X473K
C-56	1 mfd. 50 V., electrolytic	45A163	R-67	100 ohms 1/2 watt, carbon	23X20X101K
**C-59	Capacitor, temperature compensator	44A158	<b>TRANSFORMERS AND COILS</b>		
**C-60	.01 mfd. 600 V., moulded	46X35X103M		band 1	
C-61	60-20 mfd. 450 V., & 20 mfd. 400 V., electrolytic	45B113		band 2	
C-62, 70	.01 mfd. 600 V., tubular	46AY103J	T-3	Transformer, antenna stage, band 3	51B1090
C-65	1 mmf. 450 V., ceramic	47A160-2	T-4	Transformer, antenna stage, band 4	51B1091
C-69	470 mmf. 500 V., mica	47X20B471J	T-5	Transformer, antenna stage, band 5	51B1092
	<b>RESISTORS</b>		T-6	Transformer, 1st IF (2.075 MC)	50C414
R-1, 30	10 ohms 1/2 watt, carbon	23X20X100K	T-7, 8	Transformer, 1st and 2nd IF (455 KC)	50C416
R-2, 13	15 ohms 1/2 watt, carbon	23X20X150K	T-9	Transformer, 3rd IF (455 KC)	50C415
R-3, 41	1 megohm 1/2 watt, carbon	23X20X105K	T-10	Transformer, FM detector	50C418
R-4, 44	82 ohms 1/2 watt, carbon	23X20X820K	T-11	Transformer, mixer stage, band 1	51B1093
R-5	Resistor, variable, 10,000 ohms, SENSITIVITY control	25B582	T-12	Transformer, mixer stage, band 2	51B1094
R-6	8200 ohms 1/2 watt, carbon	23X20X823K	T-13	Transformer, mixer stage, band 3	51B1095
R-7, 39, 66	2.2 megohms 1/2 watt, carbon	23X20X225K	T-14	Transformer, mixer stage, band 4	51B1096
R-8	2200 ohms 1/2 watt, carbon	23X20X223K	T-15	Transformer, mixer stage, band 5	51B1097
R-9	330,000 ohms 1/2 watt, carbon	23X20X334K	T-16	Transformer, osc. stage, band 5	51B1160
			T-17	Transformer, osc. stage, band 4	51B1101

\* Used on universal model SX-71U only.

\*\* Use exact replacement part only.

## SERVICE PARTS LIST (Cont.)

Ref. No.	Description	Manufacturer's Part Number	Ref. No.	Description	Manufacturer's Part Number
<b>TRANSFORMERS AND COILS (Cont.)</b>			<b>TUBES, RECTIFIERS AND LAMPS (Cont.)</b>		
T-18	Transformer, osc. stage, band 3	51B1100	V-10	Type 68C7, 1st audio amplifier and beat frequency oscillator	90X68C7
T-19	Transformer, osc. stage, band 2	51B1099	V-11	Type 6H8, automatic volume control and automatic noise limiter	90X6H8
T-20	Transformer, osc. stage, band 1	51B1098	V-12	Type 6AL5, detector	90X6AL5
T-21	Transformer, 2.53 MC osc. stage, bands 3, 4 and 5	50C448	V-13	Type 6X6GT, audio output lamp, carrier level meter light GE #44	90X6X6GT 39A003
T-22	Transformer, power	53C174	LM-2,3	Lamp, main dial scale light GE #47	39A004
*T-22	Transformer, power (Universal)	53C175	LM-1,4		
T-23	Transformer, output	55B120-C			
L-1	Choke, RF	53A107			
L-2	Choke, filter	56B107-B			
L-3	Coil, BFO	54B039			
<b>SWITCHES</b>			<b>MISCELLANEOUS</b>		
SW-1	Switch, BAND SELECTOR Section 1 (Antenna stage) and Section 2 (Mixer stage) Section 3 (Osc. grid) Section 4 (Osc. plate) Section 5 (Converter plate and bias)	62B051 62B049 62B050 62B048	TS-1 TS-2 M-1	Terminal strip, antenna Terminal strip, speaker Escutcheon, meter Meter, carrier level (5 ma) Plate, dial drive mounting Bracket, pulley mounting Pulley, small idler Pulley, large idler Cord, dial Spring, dial cord Pointer, bandspread and main tuning Scale, dial Window, dial Plate, window support Flywheel, bandspread and main tuning Drum, bandspread and main tuning gang drives Shaft, bandspread and main tuning pulley drives Shaft, bandspread and main tuning gang drives Ring, retainer, tuning assembly drive shafts Ring, retainer, tuning assembly pulley shafts Washer, spring Coupling, bandspread gang shaft Coupling, main tuning gang shaft Shaft and index plate, band switch Collar, band switch Lock, line cord Knob, BANDSPREAD and MAIN TUNING Knob, CRYSTAL PHASING Knob, CW PITCH Knob, POWER-VOLUME, TONE and SENSITIVITY Knob, BAND SELECTOR Knob, RECEPTION Foot, rubber Crystal, 455 KC	88A032 88B578 7D124-D 82B166 89D415 67A1140 28A078 28A079 38A010 75A173 82A190 83D358-E 22B305-A 63A450 71A178 28A080 74A298 74A299 76A552 76A551 4A043 29A126 29A123 74B287 77A055 76A397 15A047 15A087 15A089 15A087 15B209 15A212 16A007 19A123
SW-2	Switch, RECEPTION	60B343			
SW-3	Switch, BFO-OFF	60A285			
SW-4	Switch, NOISE LIMITER-OFF	60A138			
SW-5	Switch, RECEIVE-STANDBY	60A139			
<b>PLUGS AND SOCKETS</b>					
PL-1	Line Cord	97B1873			
PL-2	Plug, AC shorting	35A003			
SO-1	Socket, POWER (DC operation)	6B296			
SO-2	Jack, PHONES	36A038			
SO-3	Jack, PHONO	36B048			
	Socket, octal (tube)	6B296			
	Socket, octal (tube) with center shield	6A315			
	Socket, miniature	6A347			
	Socket, tuning dial scale lamps	66B092			
	Socket, carrier lever meter dial lamps	66B091			
<b>TUBES, RECTIFIERS AND LAMPS</b>					
V-1	Type 6BA6, RF amplifier	90X6BA6			
V-2	Type 6AU6, 1st converter	90X6AU6			
V-3	Type 6BE6, 2nd converter	90X6BE6			
V-4,5	Type 6SK7, 1st and 2nd IF amplifiers	90X6SK7			
V-6	Type 6SH7, 3rd IF amplifier	90X6SH7			
V-7	Type 6C4, oscillator	90X6C4			
V-8	Type VR-150/OD3, voltage regulator	90XVR-150/OD3			
V-9	Type 5Y3GT, rectifier	90X5Y3GT			
			X-1		

\* Used on universal model SX-71U Only.

The Heilcrafters Co. reserves the right to make changes in the design of the product without notice and to incorporate these revisions in earlier models.

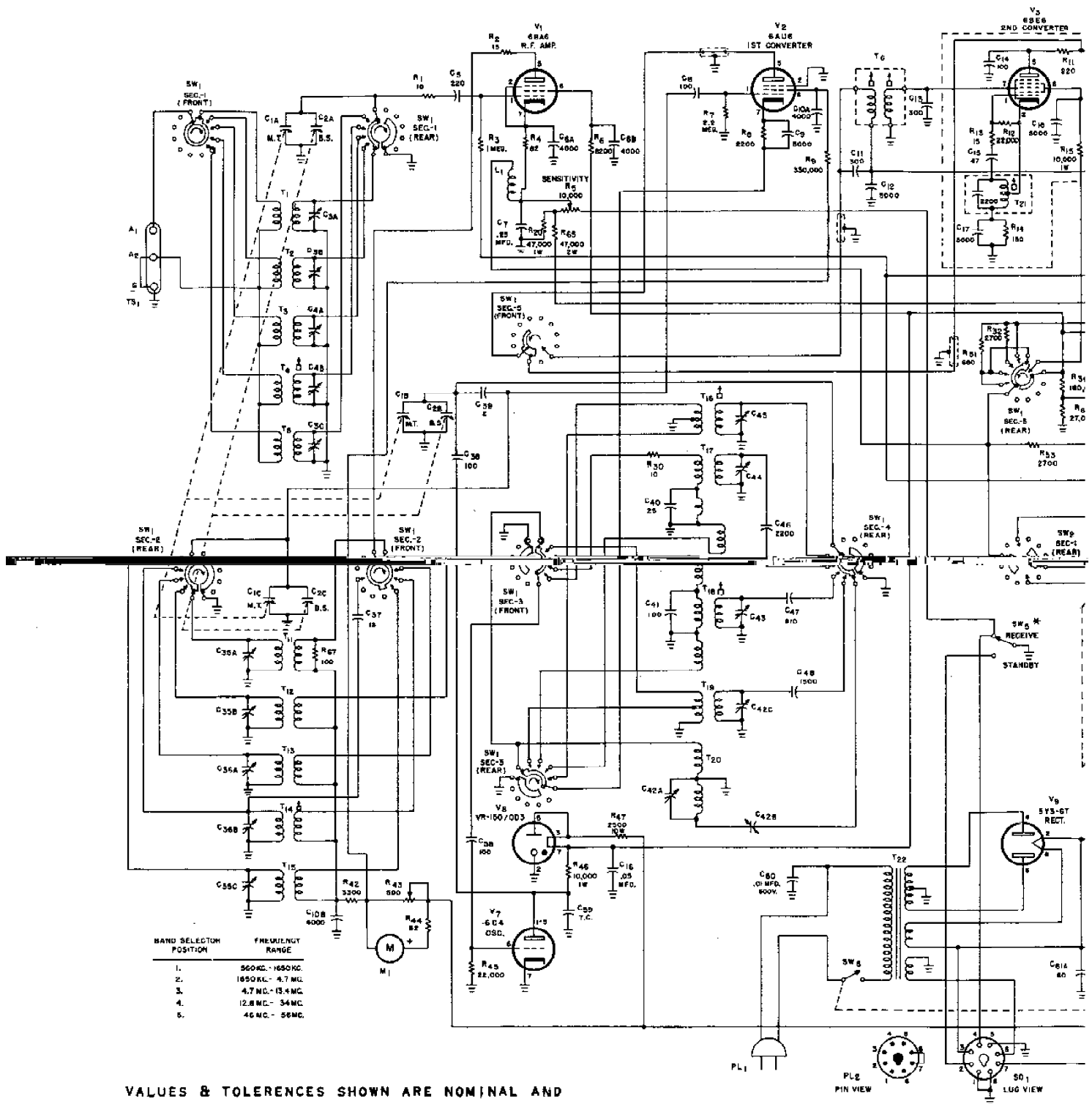

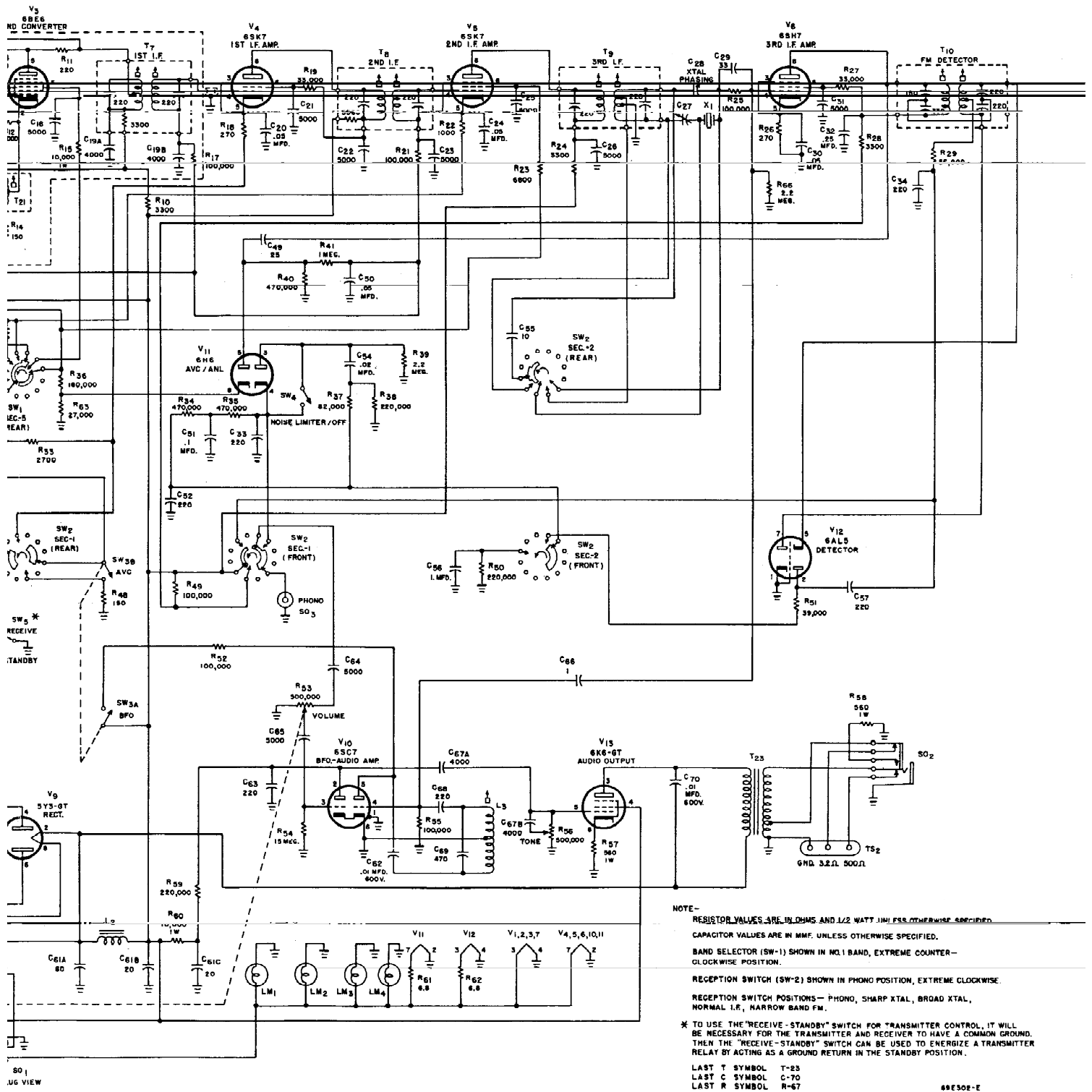

NOTE—  
 RESISTOR VALUES ARE IN OHMS AND 1/2 WATT UNLESS OTHERWISE SPECIFIED.  
 CAPACITOR VALUES ARE IN MFD. UNLESS OTHERWISE SPECIFIED.  
 BAND SELECTOR (SW-1) SHOWN IN NQ.1 BAND, EXTREME COUNTER—  
 CLOCKWISE POSITION.  
 RECEPTION SWITCH (SW-2) SHOWN IN PHONO POSITION, EXTREME CLOCKWISE.  
 RECEPTION SWITCH POSITIONS—PHONO, SHARP XTAL, BROAD XTAL,  
 NORMAL I.F., NARROW BAND FM.  
 \* TO USE THE "RECEIVE-STANDBY" SWITCH FOR TRANSMITTER CONTROL, IT WILL  
 BE NECESSARY FOR THE TRANSMITTER AND RECEIVER TO HAVE A COMMON GROUND.  
 THEN THE "RECEIVE-STANDBY" SWITCH CAN BE USED TO ENERGIZE A TRANSMITTER  
 RELAY BY ACTING AS A GROUND RETURN IN THE STANDBY POSITION.  
 LAST T SYMBOL T-23  
 LAST C SYMBOL C-70  
 LAST R SYMBOL R-67

66502-E

Fig. 10. Schematic diagram