

From the library of K4CCF

INSTALLATION AND OPERATING INSTRUCTIONS FOR RADIO RECEIVER MODEL SX-43 GENERAL INFORMATION

1. INSTALLATION

It is recommended that, upon receipt, the carton and then the unpacked receiver be carefully examined for any damage which may have occurred during shipment. Should any damage be apparent, immediately file claim with the carrier, stating the extent of damage.

IMPORTANT. Unless otherwise marked, this receiver is operated from 105 to 125 volts 50-60 cycle a-c power. If in doubt call your local utility company for information.

Connect the R-42 Reproducer, or the R-44, as the case may be, to the 500 and "C" terminals on the SX-43.

Turn the VOLUME control to the left as far as possible. (See Fig. 2) This turns off the radio. Plug the power cord into the a-c outlet.

Attach an antenna (aerial) to the post marked A-1. This antenna wire should be, preferably, outdoors above surrounding structures and from 25 to 100 feet long. Attach a wire from a good ground to the post marked GND. In general the better the antenna system, the better the signal will be heard.

Having followed instructions to this point you are now ready to operate your receiver. Let's first tune in a-m (standard broadcast) stations.

2. GENERAL OPERATION

1. To turn the receiver on, the VOLUME control is turned to the right to about 4 on the knob scale. When the receiver is on, the dial scales and the meter will light up.
2. Turn the BAND SELECTOR knob left to the red dot. (See Fig. 3)
3. Set the three toggle switches to the "right" hand position. (See Fig. 4)
4. Set four of the six right-hand control knobs to the following positions: "SENSITIVITY" to red dot, "RECEPTION" to red dot, "SENSITIVITY" to 10, and "VOLUME" to 4 or the desired amount of volume. (See Fig. 5)

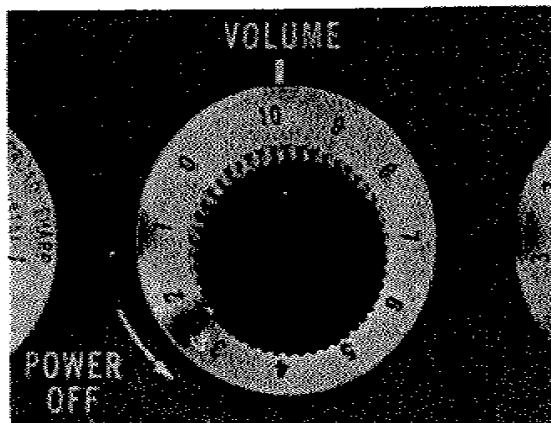

Figure 2. View showing Volume Control

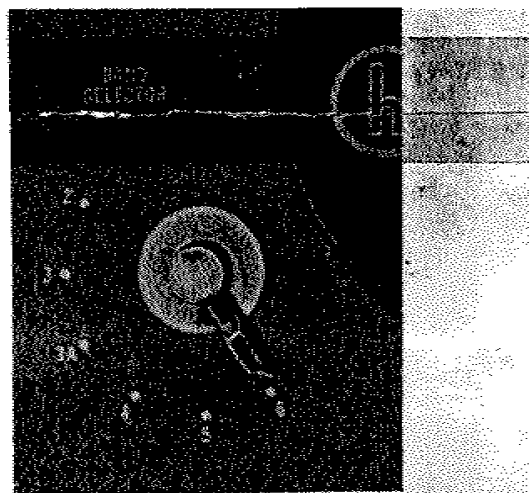

Figure 3. View showing Band Selector Switch

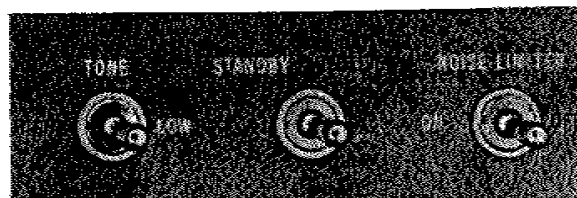

Figure 4. View showing three toggle switches

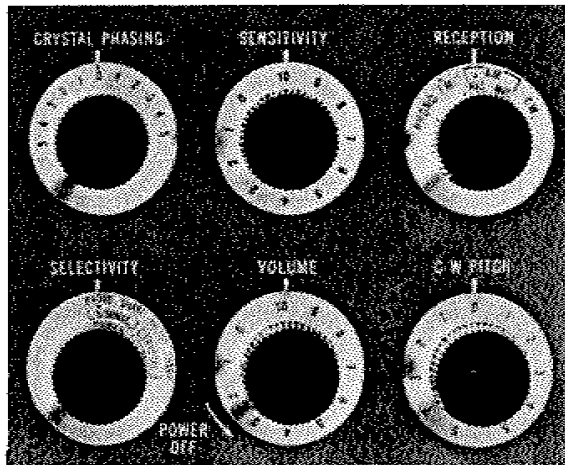

Figure 5. View showing six right hand controls

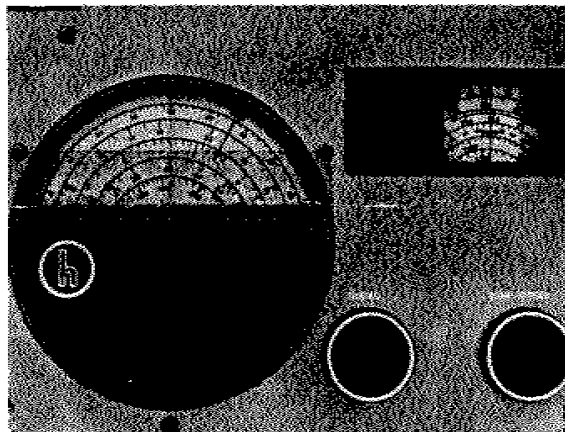

Figure 6.
View showing Bandspread and Main Tuning Dial

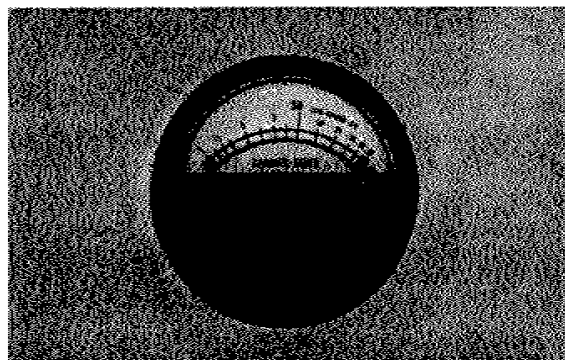

Figure 7. View showing Carrier Meter

5. Set the bandspread (fine tuning) dial to the high end of the dial, (counterclockwise).

6. Now tune in stations by tuning with the main control knob. (See Fig. 6) As the station is tuned in, the carrier meter needle (See Fig. 7) will move from the left side of the scale to the right. Carefully tune the receiver by causing the meter needle to move as far to the right as possible. At this point the receiver is properly tuned to the station.

7. To control the volume, adjust the VOLUME control (See Fig. 2) by turning it to the right for a louder signal or to the left for a softer signal.

8. The frequency calibration on the main tuning dial for the broadcast band is shown on the scale at the bottom of the dial. (See Fig. 6). This scale as all other scales is calibrated in kilocycles and tunes over the broadcast band from 540 to 1650 kc.

9. The next control which will be of interest to you, will be the TONE switch. (See Fig. 4). When it is set to the left, the receiver produces substantially all musical tones as sent out by the radio station. However, by setting this control to BASS, low notes will be amplified.

10. The next control in sequence of importance is the SELECTIVITY control (See Fig. 8). This control is very useful when it is desired to tune in a weak station on a frequency close to a powerful one, in which instance the control should be switched to SHARP.

11. The knobs for CRYSTAL PHASING, RECEPTION, C.W. PITCH, and SENSITIVITY should in all cases be left set at the red dot or "0".

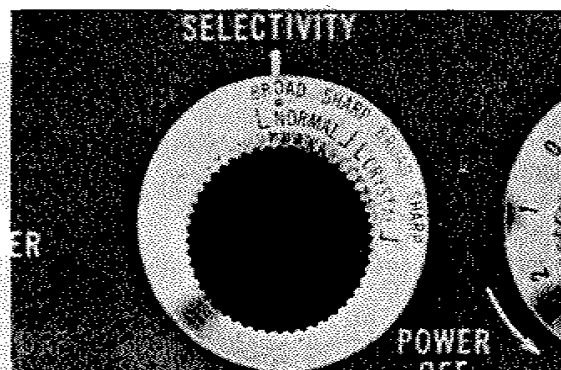

Figure 8. View showing Selectivity Control

Thus far we have tuned the receiver for a-m reception. If it is desired to use it on f-m reception, all controls should be set as previously described with the exception of the following:

1. The RECEPTION knob should be switched to FM (green dot).

2. The BAND SELECTOR switch should be set on the green dot. This covers the band 86 to 109 mc. Most f-m stations are on this band; the few that are not can be tuned in by changing the BAND SELECTOR knob to band 5, 44 to 55 mc.

3. Tune in f-m stations by turning the BAND-SPREAD tuning knob until the BANDSPREAD tuning dial indicates the desired f-m frequency. As the station is being tuned, the meter pointer will deflect when tuned to a transmitted signal.

When meter pointer is at maximum deflection the station is tuned in.

4. The carrier level meter reads the relative signal strength received as well as indicating when the signal is properly tuned in by the maximum deflection of the meter needle. When using the carrier level meter, the "Reception" switch should be set to the RED dot for AM reception or to the GREEN dot for FM reception. The "Sensitivity" control must be set to 10 and the volume controlled by the "Volume" control.

So far we have covered three bands of the receiver (Broadcast, and the f-m bands 86-109 mc and 44-55 mc). For the other three bands of the set, operation is the same, the only difference being in the setting of the BAND SELECTOR switch knob, which may be turned to the desired band.

DETAILED AND TECHNICAL OPERATING INSTRUCTIONS

1. GENERAL

The Model SX-43 is a 11 tube superheterodyne radio receiver designed to provide amplitude modulated (AM) reception over the frequency range of 540 kc to 55 mc and frequency modulated (FM) reception over the frequency range of 44 to 55 mc and 86 to 109 mc bands. Calibrated bandspread is provided for the 80, 40, 20, and the 10 meter Amateur bands.

FREQUENCY COVERAGE

BAND	COVERAGE	TYPE OF RECEPTION
1	.540 to 1.65 mc	AM/CW
2	1.65 to 5.0 mc	AM/CW
3	5.0 to 15.1 mc	AM/CW
3A	13.9 to 14.4 mc	AM/CW
4	15.1 to 44.0 mc	AM/CW
5	44.0 to 55.0 mc	AM/FM
6	86.0 to 110 mc	FM

Adequate overlap is provided at ends of all bands.

The receiver as normally supplied is designed to operate from a 105 to 125 volts 50/60 cycle, single phase source of a-c power. These operating instructions also cover Universal Models which operate from a 105 to 250 volts, 25/60 cycle single phase a-c source.

2. A-C OPERATION

Be sure line voltage is 105 to 125 volts and frequency is 50 to 60 cycles before inserting power cord plug into power outlet. Be sure all tubes are securely inserted in their proper sockets before receiver power is turned on. The chart below lists the current and voltage data.

Power Consumption	90 Watts
Frequency	50/60 Cycles
Line Voltage	117 Volts
Line Current	0.77 Amperes

During a-c operation, the shorting plug supplied with the receiver must be in the octal socket on the rear apron of the chassis.

3. D-C OPERATION

The receiver may be operated from a 6 volt d-c source, generally a storage battery, and a 270 volt d-c supply in the form of "B" batteries or vibrator type power pack. Consult the

chart on power requirements at the end of this paragraph and provide battery or power pack facilities capable of supplying these demands. The receiver is connected to the d-c supply as follows:

1. Remove the octal shorting plug for a-c operation from the socket SO-1 located on the rear apron of the receiver chassis.

2. Wire an octal plug, as shown in Fig. 9, and plug it into socket SO-1. Use #19 (AWG) wire leads for the 270 volt "B" supply connections to pins #3 and #5, and #12 (AWG) wire leads for the 6 volt battery connections to pins #1, #7, and #8. **CAUTION:** Check the wiring carefully before connecting to the battery supply. The chart below lists the current voltage data.

"B" Voltage	270 Volts
"B" Current	105 ma.
Filament Voltage	6 Volts
Filament Current	3.8 Amperes

Total battery drain when operating from a 6-volt vibrator power supply is approximately 1.1 amperes.

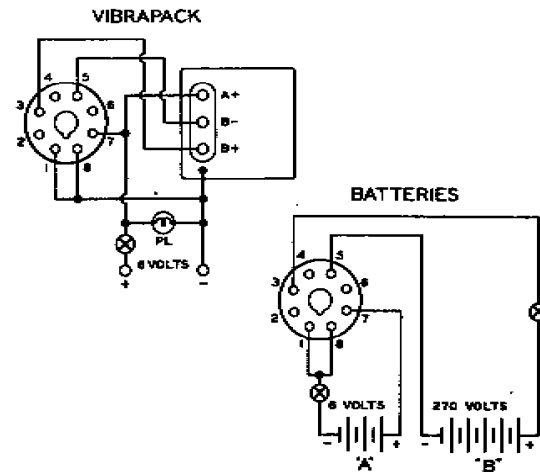

Figure 9. Octal plug wiring diagram

4. OUTPUT CONNECTIONS

Output connections for the speaker are provided for on the rear apron of the chassis. Two output impedances are available. Either the

500 or the 5,000 ohm speaker connection may be used according to the output impedance desired. This arrangement of dual output impedances will accommodate most requirements. The Hallicrafters Model PM-23 speaker requires 5000 ohms impedance; the Hallicrafters Model R-42 and R-44, requires 500/600 ohms. However, any standard type, permanent magnet dynamic speaker with proper output transformer may be connected to the output terminals. If the permanent magnet dynamic speaker impedance is unknown, try the 5000 ohm and then the 500/600 ohm impedance, and use the one which gives the better tone quality and volume.

5. PHONO INPUT CONNECTION

A receptacle is provided on the rear apron of the chassis for connecting a phonograph record player to the receiver. This receptacle is designed to accommodate a Cinch, type M-93, pin connector plug. (See Fig. 10 for diagram)

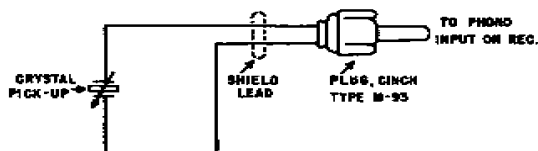

Figure 10. Phono input diagram

6. ANTENNA AND GROUND CONNECTIONS

The Model SX-43 is designed for a 300 ohm antenna impedance. The antenna impedance is not critical and excellent reception can be obtained from an antenna of from 50 to 600 ohm impedance. For maximum performance, the best possible antenna should be employed.

The antenna terminals on the Model SX-43 are arranged for any type of antenna from those requiring a ground to those using a transmission line. The transmission type of antenna connects to the A-1 and A-2 terminals whereas a single wire antenna utilizes terminal A-1 for the antenna lead. A-2 and GND terminals must be connected together and connected to a good ground.

7. DETAILED OPERATIONS

a. Controls and Their Functions. In order to obtain the desired results from the receiver, it is recommended that you become familiar with the function of each control. Red indicators on the controls for broadcast reception and green for f-m reception are there to simplify operation. Controls and their functions are as follows:

(1) BAND SELECTOR. The BAND SELECTOR knob operates the bandswitch to select the desired band frequencies.

(a) General Coverage Dial. The general coverage dial has four calibrated scales and a logging scale. Three scales are calibrated in megacycles and the broadcast scale is calibrated in kilocycles. The outer logging scale is divided into 100 divisions for logging use. The dial settings for the various amateur bands are indicated on the main tuning dial by red lines and the abbreviations 80 M, 40 M, etc. directly above the lines. When tuning the amateur bands with the calibrated bandspread dial, the general coverage dial must be set at the setting corresponding to the amateur band desired. Since the general coverage and bandspread tuning systems are electrically related on the first four bands, it is necessary to set the bandspread dial to the high frequency end or minimum capacity when tuning the receiver with the general coverage dial control to obtain correct receiver frequency readings on the general coverage dial.

(b) Bandspread Dial. The bandspread dial has four scales calibrated for the amateur bands and two scales calibrated for the two high frequency FM bands. The first four scales are calibrated to read receiver frequencies in kilocycles when the general coverage dial has been set to the corresponding indexing line. All FM and the 6 meter amateur band tuning is done with the bandspread dial as the general coverage dial and condenser is switched out of the circuit on bands 5 and 6. On band 5 the receiver employs dual conversion, substantially reducing image interference and permitting normal bandwidth for 6 meter AM amateur reception.

(2) NOISE-LIMITER-ON Switch. This switch opens or closes the noise limiter circuit and is to be set at ON when the operator wishes to limit excessive noise resulting from automobile ignition and other forms of noise interference.

The noise limiter circuit "clips" the intermittent noise peaks down to the level of the desired signal where they tend to become unnoticeable.

(3) RECEIVER-STANDBY Switch. When set at STANDBY, this switch renders the receiver

inoperative, while transmitting or for any other purpose, although the tube heaters remain hot and ready for instant use.

(4) CRYSTAL PHASING Control. This control permits the discrimination of code signals whose frequencies are very nearly the same. The SELECTIVITY control must be set at one of its two crystal selectivity positions when using the phasing control.

It is extremely simple to attain single signal c-w reception with the SX-43. First, set the RECEPTION switch at CW and the SELECTIVITY control at CRYSTAL SHARP. Pick a good solid c-w signal, preferably a commercial station because a commercial is likely to stay on long enough for you to complete the phasing adjustment for single signal reception.

You will find on tuning across this signal that it has two amplitudes. Tune first to the weaker of these two amplitudes. Now, turn the CRYSTAL PHASING control until the weaker of the two amplitudes is reduced to a minimum. Then, tune to the stronger of the two amplitudes and adjust the PITCH control to a tone most pleasing to you. This adjustment for single signal selectivity will hold with no further adjustment unless you change the phasing control. (See Fig. 11 for an illustration of single signal operation.)

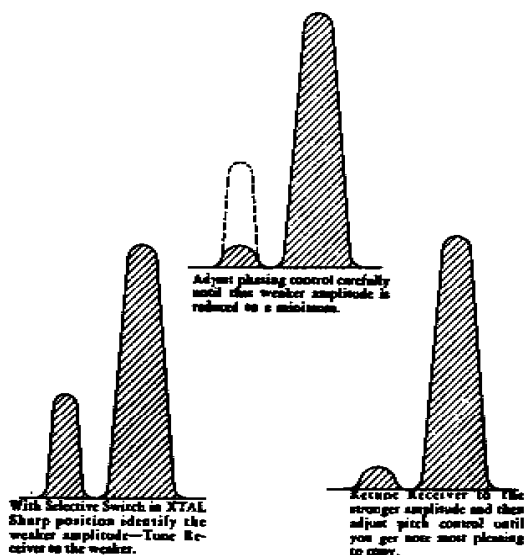

Figure 11.

Illustration showing Single Signal Operation

(5) SELECTIVITY Control. This control determines the sharpness of the response. Four degrees of selectivity are provided, ranging from CRYSTAL SHARP for c-w code reception under difficult receiving conditions to NORMAL BROAD response for BC reception.

1. BROAD I-F (for high fidelity reception).
2. SHARP I-F (reduced adjacent channel interferences and gives less highs).
3. CRYSTAL BROAD (similar to sharp i-f but sharper cutting on sidebands).
4. CRYSTAL SHARP (position of extreme selectivity - practically no sideband content).

(6) LOF Control. This control selects the tone qualities desired by the operator. The types of response available are LOW, and HIGH.

(a) LOW. The high audio frequencies are attenuated to provide a minimum response for voice reception when the background noise level is objectionably high.

(b) HIGH. The bass and high frequencies are passed at the same level thereby providing as near a true reproduction of the original transmitted signal as possible. The response is essentially flat between 70 and 8,000 cycles per second for good fidelity reception.

(7) CW PITCH Control. This control varies the frequency of the beat frequency oscillator thus varying the pitch of the c-w code signal as desired.

(8) SENSITIVITY Control. This control adjusts the sensitivity by varying the resistance in the cathodes of the r-f and i-f amplifiers. Turning the control to the right increases the sensitivity. This control must be set at maximum sensitivity when using the carrier level meter. At any other setting of this control, readings of the carrier meter are meaningless.

8. "S" METER ADJUSTMENT

Adjustment of the "S" meter control is performed by varying the knurled knob located on the rear apron of the receiver chassis. This control enables you to properly set the "S"

meter to zero. In order to make the adjustment correctly, advance the SENSITIVITY control to 10. Set the "reception" switch to AVC position. Short the two antenna terminals to the ground terminal and tune receiver off station. Then

adjust the "S" meter control until pointer rests at "0". Remove the short from the antenna terminals and the meter will indicate the relative carrier strength of each incoming signal as it is tuned in.

SERVICE

1. REPLACING TUBES

All tubes are accessible at the top of the chassis through the hinged cover of the cabinet. When replacing tubes, check tube type carefully and replace with the correct type. Refer to top view of the chassis to determine the location of the tubes (See Fig. 12).

2. REPLACING DIAL LAMPS

The receiver employs three dial lamps with the bayonet type sockets to illuminate the main and bandspread tuning dials as well as the

meter scale. The lamps are to be replaced with 6-8 volt, 250 ma, (blue bead) #44 G.E. type, or equivalent. The color code referred to is the color of the glass bead above the glass stem inside the envelope of the lamps.

3. SERVICE OR OPERATING QUESTIONS

For further details regarding operation or servicing of the receiver, contact your dealer directly. Make no service shipments directly to the factory before first writing for authorization and instructions. *The factory cannot accept responsibility for unauthorized shipments.*

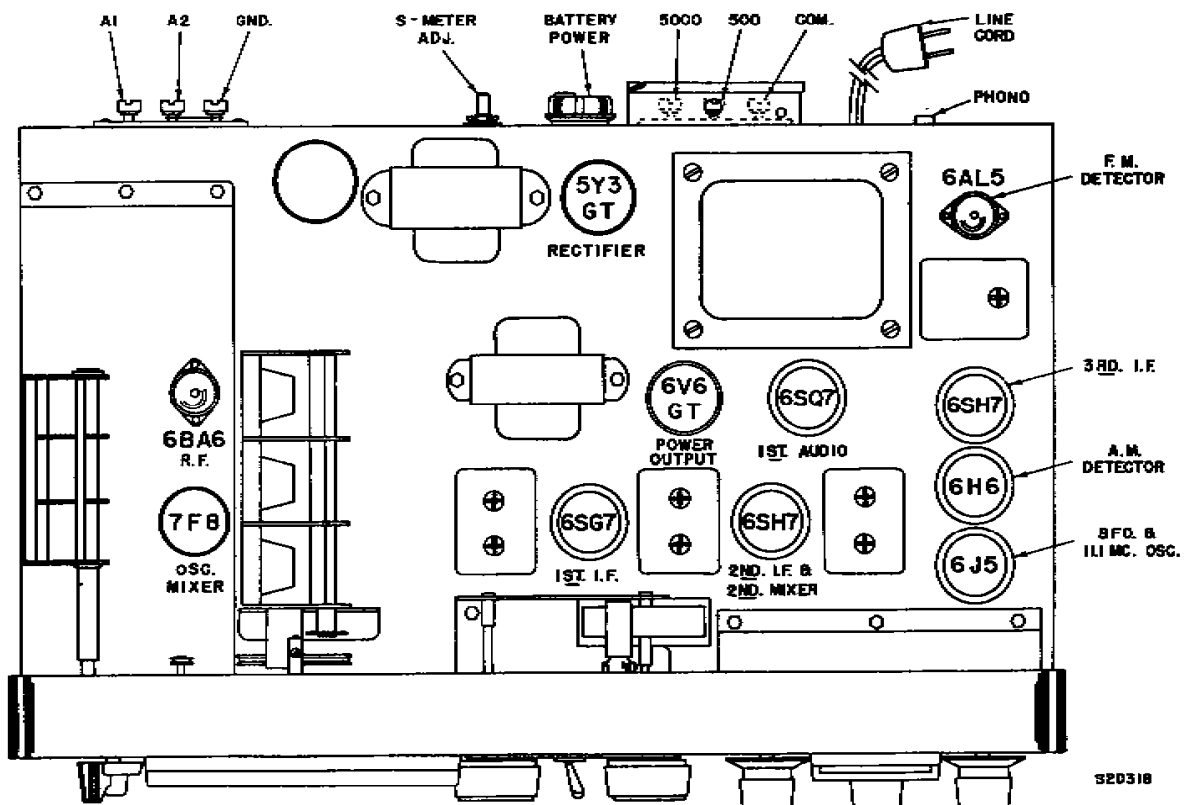

Figure 12. Top view of Chassis

REMOTE CONTROL OPERATION

Connect a single pole single throw relay to pins #5 and 8 on PL1 located on the rear apron

of the receiver. Receiver "SEND- RECEIVE" switch is then placed in "SEND" position. When the Transmitter is turned on the Receiver is automatically disabled.

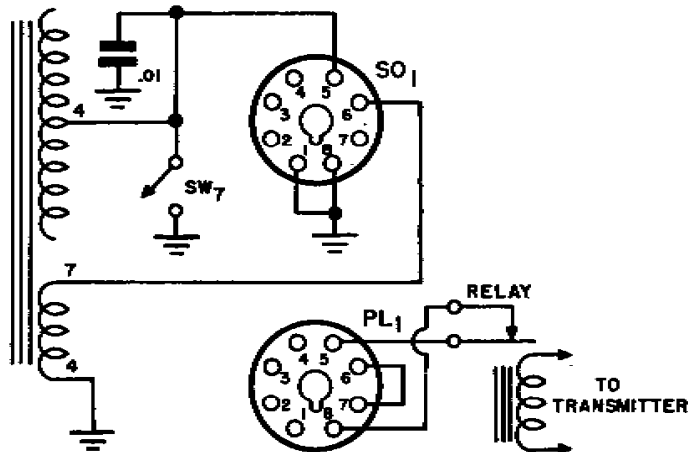
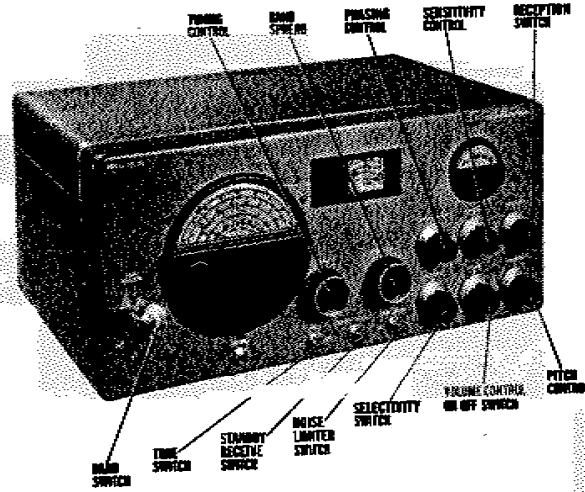

Figure 13. Schematic Remote Control Operation

From the library of K4CCF

**HALLICRAFTERS MODEL
SX-43**

**HALLICRAFTERS MODEL
SX-43**



HALLICRAFTERS MODEL SX-43

**HALLICRAFTERS MODEL
SX-43**

TRADE NAME	Hallcrafters, Model SX-43		
MANUFACTURER	Hallcrafters Co., 5th & Kostner Avenues, Chicago 24, Ill.		
TYPE SET	AC Operated Multi-Band AM-FM Commercial Communications Receiver		
TUBES (ELEVEN)	Types, 6BA6 RF Amp., 7F8 Converter, 6SQ7 1st IF Amp., 6SE7 2nd IF-2nd Mixer, 6SH7 3rd IF Amp., 6AL5 FM Ratio Det., 6NS AM Det., 6J5 BFO-2nd Osc., 6SQ7 AF Amp., 6V6GT Power Output, 5Y3GT Rectifier.		
POWER SUPPLY	105-125 Volts AC		
RATING	.68 Amp. @ 117 Volts AC		
TUNING RANGE-BROADCAST	540-1700KC	SHORT WAVE	1.7-5ME, 5-16ME, 14-14.4ME, 15.5-44ME, 44-55ME
		FREQ. MOD.	44-55ME, 86-109ME

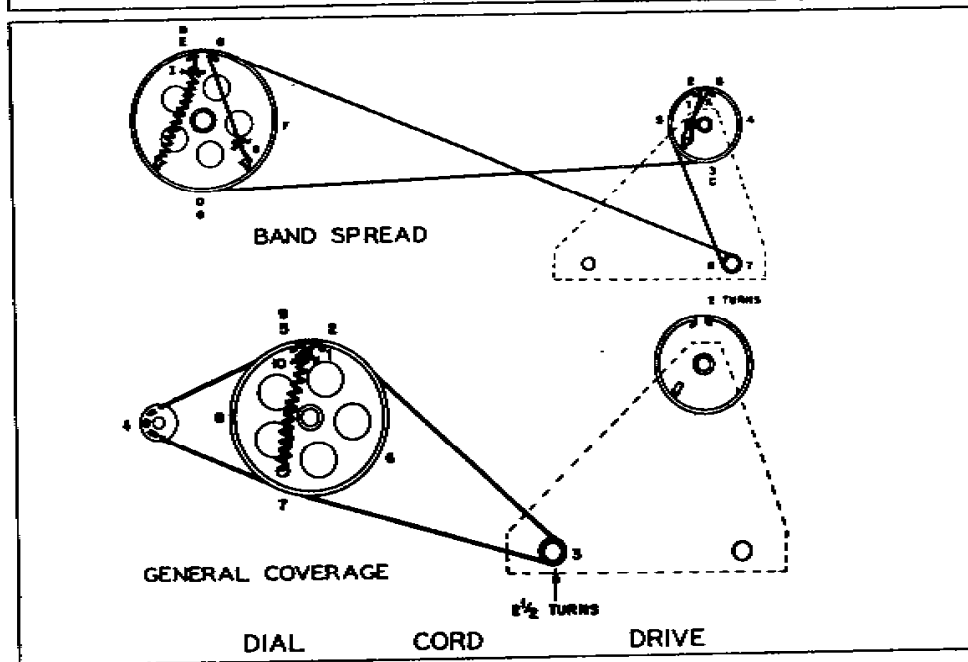

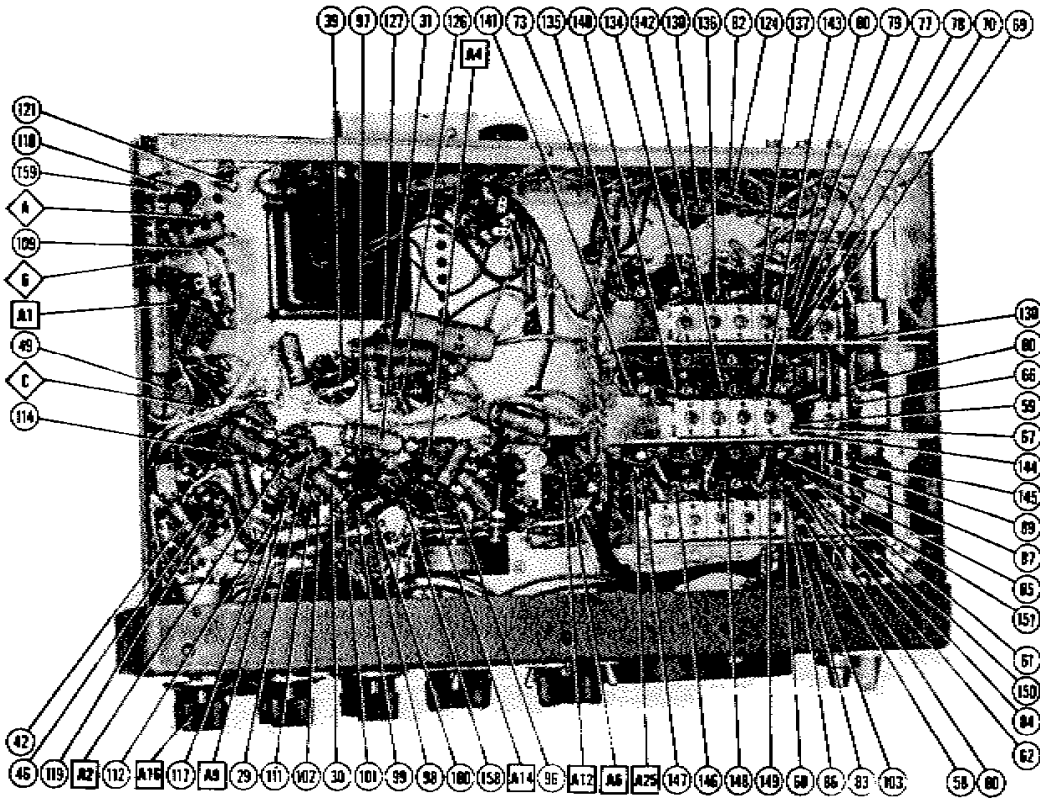
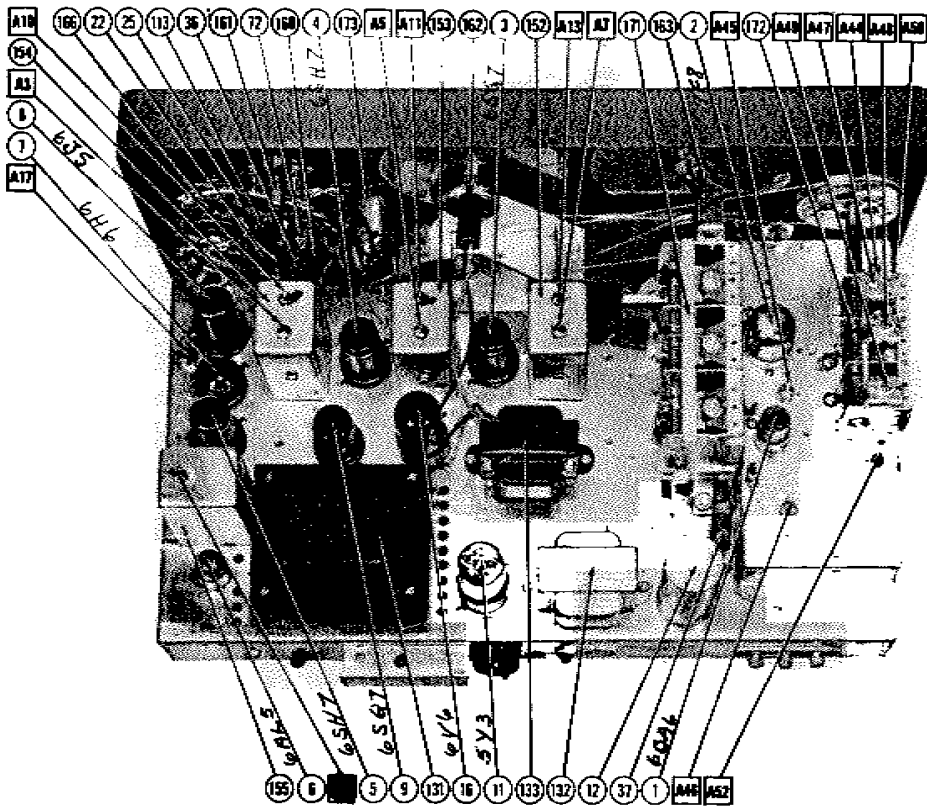

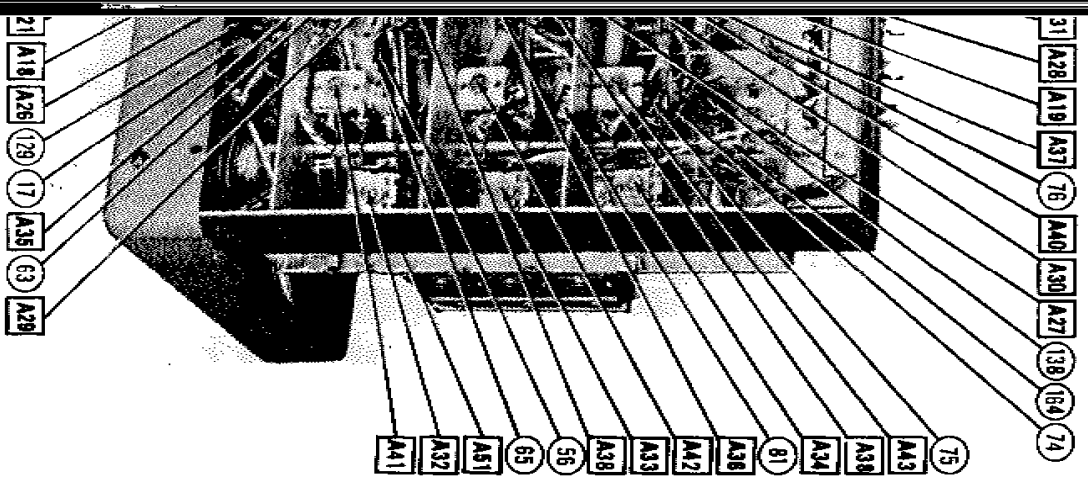
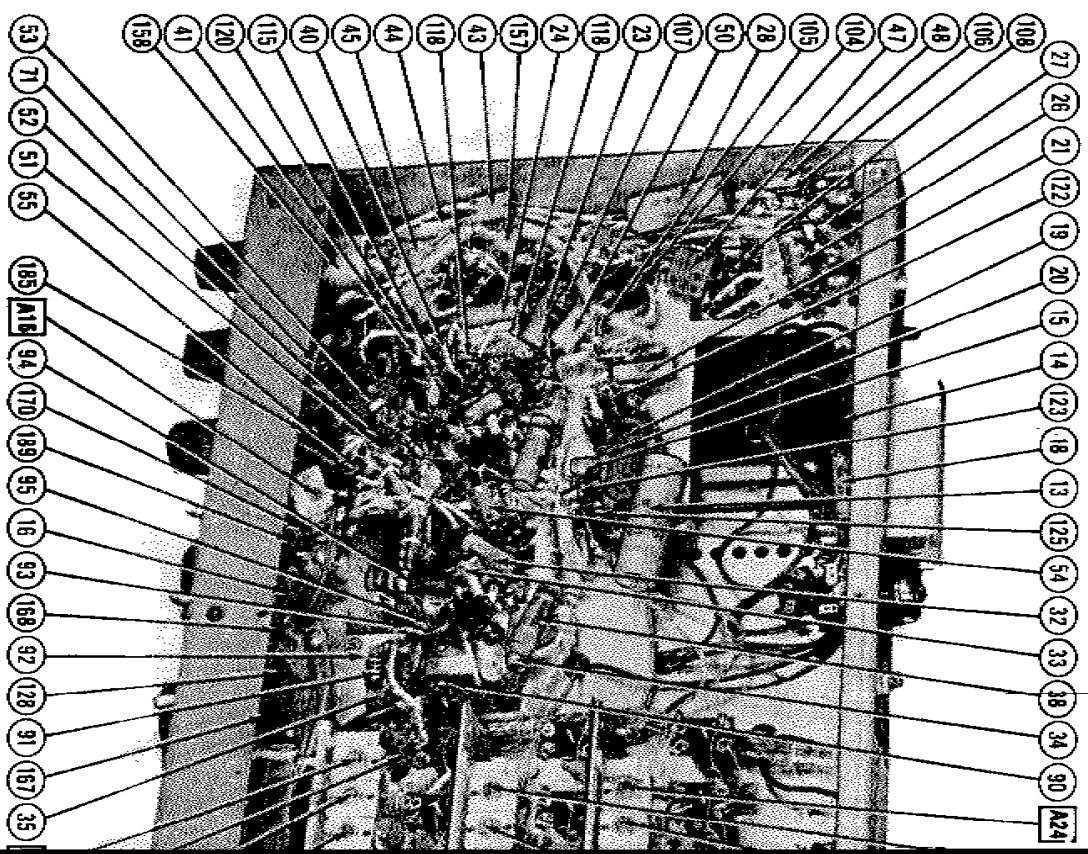

PARTS LIST AND DESCRIPTIONS TUBES (SYLVANIA or Equivalent)

ITEM No.	USE	REPLACEMENT DATA			MVA BASE TYPE	IDENTIFICATION CODES
		HALLICRAFTERS PART No.	STANDARD SERIALS	GENERAL PART No.		
1	1st 6.3V 6X4	792	6848	792	6X4	
2	2nd 6.3V 6X4	793	6849	793	6X4	
3	3rd 6.3V 6X4	794	6850	794	6X4	
4	4th 6.3V 6X4	795	6851	795	6X4	
5	5th 6.3V 6X4	796	6852	796	6X4	
6	6th 6.3V 6X4	797	6853	797	6X4	
7	7th 6.3V 6X4	798	6854	798	6X4	
8	8th 6.3V 6X4	799	6855	799	6X4	
9	9th 6.3V 6X4	800	6856	800	6X4	
10	10th 6.3V 6X4	801	6857	801	6X4	
11	Rectifier	5700T	5700T	5700T	5700T	

CAPACITORS

Capacity values given in the rating column are in mfd. for Electrolytic and Paper Capacitors, and in mmfd. for Mica and Ceramic Capacitors.

ITEM No.	RATING	MULTIPLYERS		REPLACEMENT DATA		SOLAR PART No.	SPRAGUE PART No.	IDENTIFICATION CODES AND INSTALLATION NOTES
		HALL	GEN	HALLICRAFTERS PART No.	ARROVOX PART No.			
13A	50	1.0	1.0	484033	484033	484033	484033	Filter
B	20	1.0	1.0	484033	484033	484033	484033	Filter
13	100	1.0	1.0	484033	484033	484033	484033	Filter
14	100	1.0	1.0	484033	484033	484033	484033	Filter
15	100	1.0	1.0	484033	484033	484033	484033	Filter
16	100	1.0	1.0	484033	484033	484033	484033	Filter
17	100	1.0	1.0	484033	484033	484033	484033	Filter
18	100	1.0	1.0	484033	484033	484033	484033	Filter
19	100	1.0	1.0	484033	484033	484033	484033	Filter
20	100	1.0	1.0	484033	484033	484033	484033	Filter
21	100	1.0	1.0	484033	484033	484033	484033	Filter
22	100	1.0	1.0	484033	484033	484033	484033	Filter
23	100	1.0	1.0	484033	484033	484033	484033	Filter
24	100	1.0	1.0	484033	484033	484033	484033	Filter
25	100	1.0	1.0	484033	484033	484033	484033	Filter
26	100	1.0	1.0	484033	484033	484033	484033	Filter
27	100	1.0	1.0	484033	484033	484033	484033	Filter
28	100	1.0	1.0	484033	484033	484033	484033	Filter
29	100	1.0	1.0	484033	484033	484033	484033	Filter
30	100	1.0	1.0	484033	484033	484033	484033	Filter
31	100	1.0	1.0	484033	484033	484033	484033	Filter
32	100	1.0	1.0	484033	484033	484033	484033	Filter
33	100	1.0	1.0	484033	484033	484033	484033	Filter
34	100	1.0	1.0	484033	484033	484033	484033	Filter
35	100	1.0	1.0	484033	484033	484033	484033	Filter
36	100	1.0	1.0	484033	484033	484033	484033	Filter
37	100	1.0	1.0	484033	484033	484033	484033	Filter
38	100	1.0	1.0	484033	484033	484033	484033	Filter
39	100	1.0	1.0	484033	484033	484033	484033	Filter
40	100	1.0	1.0	484033	484033	484033	484033	Filter
41	100	1.0	1.0	484033	484033	484033	484033	Filter
42	100	1.0	1.0	484033	484033	484033	484033	Filter
43	100	1.0	1.0	484033	484033	484033	484033	Filter
44	100	1.0	1.0	484033	484033	484033	484033	Filter
45	100	1.0	1.0	484033	484033	484033	484033	Filter
46	100	1.0	1.0	484033	484033	484033	484033	Filter
47	100	1.0	1.0	484033	484033	484033	484033	Filter
48	100	1.0	1.0	484033	484033	484033	484033	Filter
49	100	1.0	1.0	484033	484033	484033	484033	Filter
50	100	1.0	1.0	484033	484033	484033	484033	Filter
51	100	1.0	1.0	484033	484033	484033	484033	Filter
52	100	1.0	1.0	484033	484033	484033	484033	Filter
53	100	1.0	1.0	484033	484033	484033	484033	Filter
54	100	1.0	1.0	484033	484033	484033	484033	Filter
55	100	1.0	1.0	484033	484033	484033	484033	Filter
56	100	1.0	1.0	484033	484033	484033	484033	Filter
57	100	1.0	1.0	484033	484033	484033	484033	Filter
58	100	1.0	1.0	484033	484033	484033	484033	Filter
59	100	1.0	1.0	484033	484033	484033	484033	Filter
60	100	1.0	1.0	484033	484033	484033	484033	Filter

PARTS LIST AND DESCRIPTIONS (Continued) RESISTORS

ITEM No.	RATING	REPLACEMENT DATA			IDENTIFICATION CODES
		HALLICRAFTERS PART No.	GEN. PART No.	STANDARD SERIALS	
113	2.2 1/2W	R200A22K	R200A22K	R200A22K	Red-Red-Grn. Avg Network
114	1500	R200A15K	R200A15K	R200A15K	Br-Grn-Br. Avg Shunt
115	2.7 1/2W	R200A27K	R200A27K	R200A27K	Red-Grn-Grn. Noise Limiter Load
116	500	R200A50K	R200A50K	R200A50K	Gray-Red-Grn. Noise Limiter Load
117	1.5 1/2W	R200A15K	R200A15K	R200A15K	Br-Grn-Grn. Noise Limiter Bias Network
118	1.5 1/2W	R200A15K	R200A15K	R200A15K	Red-Grn-Grn. Noise Limiter Bias Network
119	1.5 1/2W	R200A15K	R200A15K	R200A15K	Br-Grn-Grn. Noise Limiter Bias Network
120	1.5 1/2W	R200A15K	R200A15K	R200A15K	Br-Grn-Grn. Noise Limiter Bias Network
121	1.5 1/2W	R200A15K	R200A15K	R200A15K	Br-Grn-Grn. Noise Limiter Bias Network
122	1.5 1/2W	R200A15K	R200A15K	R200A15K	Br-Grn-Grn. Noise Limiter Bias Network
123	2200	R200A22K	R200A22K	R200A22K	Br-Grn-Grn. Noise Limiter Bias Network
124	1000	R200A10K	R200A10K	R200A10K	Red-Red-Grn. Avg Network
125	4700	R200A47K	R200A47K	R200A47K	Br-Grn-Grn. Noise Limiter Bias Network
126	500	R200A50K	R200A50K	R200A50K	Br-Grn-Grn. Noise Limiter Bias Network
127	500	R200A50K	R200A50K	R200A50K	Br-Grn-Grn. Noise Limiter Bias Network
128	1000	R200A10K	R200A10K	R200A10K	Br-Grn-Grn. Noise Limiter Bias Network
129	4700	R200A47K	R200A47K	R200A47K	Br-Grn-Grn. Noise Limiter Bias Network
130	4700	R200A47K	R200A47K	R200A47K	Br-Grn-Grn. Noise Limiter Bias Network

TRANSFORMER (POWER)

ITEM No.	RATING	REPLACEMENT DATA			IDENTIFICATION CODES
		HALLICRAFTERS PART No.	GEN. PART No.	STANDARD SERIALS	
131	117V AC 150W	R200A117V	R200A117V	R200A117V	Red-Red-Grn. Avg Network
132	117V AC 150W	R200A117V	R200A117V	R200A117V	Red-Red-Grn. Avg Network

FILTER CHOKE

ITEM No.	RATING	REPLACEMENT DATA			IDENTIFICATION CODES
		HALLICRAFTERS PART No.	GEN. PART No.	STANDARD SERIALS	
133	1000	R200A10K	R200A10K	R200A10K	Red-Red-Grn. Avg Network
134	1000	R200A10K	R200A10K	R200A10K	Red-Red-Grn. Avg Network

TRANSFORMER (OUTPUT)

ITEM No.	RATING	REPLACEMENT DATA			IDENTIFICATION CODES
		HALLICRAFTERS PART No.	GEN. PART No.	STANDARD SERIALS	
135	1000	R200A10K	R200A10K	R200A10K	Red-Red-Grn. Avg Network
136	1000	R200A10K	R200A10K	R200A10K	Red-Red-Grn. Avg Network

R F COILS

ITEM No.	USE	REPLACEMENT DATA			IDENTIFICATION CODES
		HALLICRAFTERS PART No.	GEN. PART No.	STANDARD SERIALS	
137	1000	R200A10K	R200A10K	R200A10K	Red-Red-Grn. Avg Network
138	1000	R200A10K	R200A10K	R200A10K	Red-Red-Grn. Avg Network
139	1000	R200A10K	R200A10K	R200A10K	Red-Red-Grn. Avg Network
140	1000	R200A10K	R200A10K	R200A10K	Red-Red-Grn. Avg Network
141	1000	R200A10K	R200A10K	R200A10K	Red-Red-Grn. Avg Network
142	1000	R200A10K	R200A10K	R200A10K	Red-Red-Grn. Avg Network
143	1000	R200A10K	R200A10K	R200A10K	Red-Red-Grn. Avg Network
144	1000	R200A10K	R200A10K	R200A10K	Red-Red-Grn. Avg Network
145	1000	R200A10K	R200A10K	R200A10K	Red-Red-Grn. Avg Network
146	1000	R200A10K	R200A10K	R200A10K	Red-Red-Grn. Avg Network
147	1000	R200A10K	R200A10K	R200A10K	Red-Red-Grn. Avg Network
148	1000	R200A10K	R200A10K	R200A10K	Red-Red-Grn. Avg Network
149	1000	R200A10K	R200A10K	R200A10K	Red-Red-Grn. Avg Network

PARTS LIST AND DESCRIPTIONS (Continued)

CAPACITORS

Capacity values given in the rating column are in mfd. for electrolytic and Paper Capacitors, and in mmfd. for Mica and Ceramic Capacitors.

ITEM No.	RATING	REPLACEMENT DATA				IDENTIFICATION CODES	INSTALLATION NOTES
		HALLICRAFTERS PART No.	ABBOVON PART No.	CORNELL DUBIER PART No.	SOVAR PART No.		
80	Temp. Comp.	44A159				OC. Plate bypass	
81	500	C220M510K	1488-00005	5M525	MO 5-45	OC. PLATE CAP.-Cer.	
82	500	C220M510K	1488-0001	5M525	1P7-45	OC. PLATE CAP.-Cer.	
83	500	C220M510K	1488-0001	5M525	1P7-51	Fixed Res.	
84	500	C220M510K	1488-0001	5M525	1P7-51	Fixed Res.	
85	15	500	1488-0015	1M5D15	MV 5-215	Fixed Trimmer-Cer.	
86	15	500	1488-00025	5M525	MO 5-425	Fixed Trimmer-Cer.	
87	1500	360	47A141	1M5D15	MO 5-465	Fixed Trimmer-Cer.	
88	1500	360	47A141	1M5D15	MO 5-465	Fixed Trimmer-Cer.	
89	1500	360	47A141	1M5D15	MO 5-465	Fixed Trimmer-Cer.	
90	1500	360	47A141	1M5D15	MO 5-465	Fixed Trimmer-Cer.	
91	10000	360	47A141	1M5D15	MO 5-465	Fixed Trimmer-Cer.	

Note-Not used in some models.

CONTROLS

ITEM No.	RATING	REPLACEMENT DATA				CLASSICAT PART No.	INSTALLATION NOTES
		HALLICRAFTERS PART No.	ABBOVON PART No.	CORNELL DUBIER PART No.	SOVAR PART No.		
71A	2 Mag.				D13-139	M-66-2	
B	Start				A	Volume Control	
72	1000				D18-118	Attach to 71A per instructions	
B	Start				A	Sensitivity Control	
73	1000				M-500	Attach to 72A per instructions	
					A	Per instructions	

RESISTORS

ITEM No.	RATING	REPLACEMENT DATA				IDENTIFICATION CODES
		HALLICRAFTERS PART No.	ABBOVON PART No.	CORNELL DUBIER PART No.	SOVAR PART No.	
74	27K				R220A105K	V1-V1-Blk. Att. Leaking
75	1 Meg.				R220A105K	Red-V1-Blk. Par. Resistor
76	5.6K				R220A105K	Br.-Blk.-Orn. AVC Network
77	5.6K				R220A105K	Orn.-Blue-Gold Par. Suppressor
78	27K				R220A105K	Blue-Gray-Blk. Par. Cathode
79	27K				R220A105K	Red-V1-Or. Bleeder
80	150K				R220A105K	Grn.-Orn.-Or. Rf Screen Dropping
81	150K				R220A105K	Grn.-Blue-Gold Par. Suppressor
82	1000K				R220A105K	V1-Or.-Blk. Par. Suppressor
83	27K				R220A105K	Or.-Or.-Blk. Par. Suppressor
84	27K				R220A105K	Red-Red-Or. Osc. Grid
85	100K				R220A105K	Br.-Blk.-Or. Osc. Plate Load
86	100K				R220A105K	Red-Red-Orn. Conv. Grid
87	2.2 Meg.				R220A105K	Br.-Blk.-Red Conv. Cathode
88	1000K				R220A105K	Br.-Orn.-Blk. Par. Suppressor
89	150				R220A105K	Br.-Blk.-Blk. Par. Suppressor
90	100				R220A105K	V1-V1-Or. Conv. Plate Dropping
91	47K				R220A105K	Red-Red-Or. Bleeder to Cathode
92	27K				R220A105K	Or.-Or.-Blk. Att. to IF Screen
93	150K				R220A105K	Red-V1-Or. Bleeder
94	150K				R220A105K	Or.-Or.-Red Att. to IF Screen
95	27K				R220A105K	Br.-Blk.-Orn. End IF Grid
96	3300R				R220A105K	Gray-Red-Blk. Series w/ Meter
97	1 Meg.				R220A105K	Br.-Orn.-Br. End IF Cathode
98	250				R220A105K	Blue-Gray-Br. End IF Cathode
99	150K				R220A105K	Or.-Or.-Blk. End IF Screen
100	450K				R220A105K	Br.-Blk.-Red End IF Cathode
101	330K				R220A105K	Or.-Or.-Blk. End IF Cathode
102	1000K				R220A105K	Red-Red-V1. 3rd IF Decoupling
103	220K				R220A105K	Red-Red-V1. 2nd IF Grid
104	100K				R220A105K	Br.-Blk.-Orn. AVC Network
105	1 Meg.				R220A105K	Br.-Orn.-Br. Par. Suppressor
106	100K				R220A105K	Br.-Blk.-V1. 3rd IF Decoupling
107	100K				R220A105K	Br.-Blk.-V1. De-emphasize
108	100K				R220A105K	Br.-Blk.-V1. Ratio Det. Diode Load
109	100K				R220A105K	Br.-Blk.-V1. Ratio Det. Diode Load
110	100K				R220A105K	Br.-Blk.-V1. Ratio Det. Diode Load
111	100K				R220A105K	Br.-Blk.-V1. AM Diode Filter

PARTS LIST AND DESCRIPTIONS (Continued)

R F COILS

ITEM No.	UHF	DC DEL.	REPLACEMENT DATA		INSTALLATION NOTES
			HALLICRAFTERS PART No.	ABBOVON PART No.	
149	Obs. Coil 4	11	OC	515500	Includes both secondaries. Includes both primaries.
150	" " " 5	11	OC	515500	
151	" " " 6	11	OC	515500	
152	1st IF AM	9.40	OC	515500	
153	2nd IF AM	7.40	OC	515500	
154	3rd IF AM	11	OC	515500	
155	4th IF AM	9.60	OC	515500	
156	5th IF AM	8.8	OC	515500	
157	6th IF AM	8.8	OC	515500	
158	7th IF AM	8.8	OC	515500	

DIAL LIGHT

ITEM No.	BAR TYPE	VOLTS	AMP.	REPLACEMENT DATA		INSTALLATION NOTES
				SPAD COILS	HALLICRAFTERS PART No.	
181	Hexagon	6-8	0.15	Brown	38A00A	Type 47
182	"	"	0.25	Blue	"	Type 44

MISCELLANEOUS

ITEM No.	PART NAME	HALLICRAFTERS PART No.	NOTES
184	Switch	602501	Band
185	"	602501	Selectivity
186	"	602501	Recapitulation
187	"	602501	Stator-Receiver
188	"	602501	Noise Limiter
189	"	602501	4580C
190	"	602501	(15-475RFD) Each section (AM)
191	"	602501	(Bandspread-FH)
192	"	602501	AI5
193	"	602501	AI18, A21, A28, A36, A38
194	"	602501	AI19, A23, A27, A36
195	"	602501	A30, A34, A38, A37
196	"	602501	A32, A33, A34, A48, A49
197	"	602501	A41, A42, A48, A47
198	"	602501	Carrier Lev. 1

REPLACING LAMPS
The two dial lamps and meter lamp are accessible through the hinged cabinet cover. Remove two screws holding the metal light shield to expose the dial lamps. Replace these with 6-8V, 250MA, OB, #44 (Blue bead) or equivalent. The carrier level meter lamp is made accessible by removing the four screws holding the protective cover located directly behind the meter. Replace this lamp with a 6-8 V, 150 MA, #47 (Brown bead) or equivalent. Do not use a 250 MA. lamp in the meter housing as the excessive heat will discolor the meter scale.

HALLICRAFTERS MODEL
SX-43

VOLTAGE AND RESISTANCE READINGS TAKEN IN BROADCAST POSITION.

VOLTAGE READINGS

Item	Tube	Pin 1	Pin 2	Pin 3	Pin 4	Pin 5	Pin 6	Pin 7	Pin 8
1	6BA6	OV.	OV.	6.3VAC	OV.	250VDC	120VDC	8VDC	-
2	7F8	-2VDC*	OV.	160VDC	OV.	.6VDC	65VDC	6.3VAC	-.5VDC
3	6SQ7	OV.	6.3VAC	1.6VDC	OV.	1.6VDC	155VDC	OV.	260VDC
4	6SH7	OV.	6.3VAC	4.6VDC	OV.	4.6VDC	225VDC	OV.	270VDC
5	6SH7*	OV.	OV.	OV.	-.4VDC	OV.	35VDC	6.3VAC	35VDC
6	6AL5*	OV.	OV.	OV.	6.3VAC	.4VDC	OV.	-.4VDC	-
7	6H6	OV.	OV.	OV.	OV.	-.5VDC	OV.	6.3VAC	OV.
8	6J5**	OV.	OV.	160VDC	OV.	-6.4VDC*	OV.	6.3VAC	OV.
9	6SQ7	OV.	-.4VDC	OV.	OV.	OV.	120VDC	OV.	6.3VAC
10	6V6GT	OV.	OV.	280VDC	270VDC	OV.	240VDC	6.3VAC	12.5VDC
11	5Y3GT	OV.	290VDC	OV.	265VAC	OV.	265VAC	OV.	290VDC

*TAKEN WITH VACUUM TUBE VOLTMETER.

RESISTANCE READINGS

Item	Tube	Pin 1	Pin 2	Pin 3	Pin 4	Pin 5	Pin 6	Pin 7	Pin 8
1	6BA6	5.6 Meg.	0Ω	.1Ω	0Ω	20KΩ	15KΩ	78Ω	-
2	7F8	22KΩ	0Ω	30KΩ	0Ω	1KΩ	20KΩ	.1Ω	2.2 Meg.
3	6SQ7	0Ω	.1Ω	92Ω	2.6 Meg.	92Ω	15KΩ	0Ω	24KΩ
4	6SH7	0Ω	.1Ω	690Ω	5Ω	690Ω	50KΩ	0Ω	24KΩ
5	6SH7*	0Ω	0Ω	0Ω	280KΩ	0Ω	120KΩ	.1Ω	120KΩ
6	6AL5*	INF.	INF.	0Ω	.1Ω	100KΩ	0Ω	100KΩ	-
7	6H6	0Ω	0Ω	1.5 Meg.	1.5 Meg.	400KΩ	0Ω	.1Ω	0Ω
8	6J5**	0Ω	0Ω	25KΩ	0Ω	47KΩ	0Ω	.1Ω	4Ω
9	6SQ7	0Ω	15 Meg.	0Ω	0Ω	0Ω	240KΩ	0Ω	.1Ω
10	6V6GT	0Ω	0Ω	20KΩ	23KΩ	470KΩ	20KΩ	.1Ω	28Ω
11	5Y3GT	INF.	20KΩ	INF.	70Ω	INF.	65Ω	INF.	20KΩ

* VOLTAGE AND RESISTANCE READINGS TAKEN IN FM POSITION.

RECEIVE-STANDBY SWITCH IN RECEIVE POSITION.

**TAKEN IN CW POSITION. NOISE LIMITER OFF.

SENSITIVITY CONTROL FULL ON.

SELECTIVITY CONTROL FULL ON.

TONE HIGH.

- 1 - DC Voltage measurements are at 20,000 ohms per volt; AC Voltages measured at 1000 ohms per volt.
- 2 - Socket connections are shown as bottom views.
- 3 - Measured values are from socket pin to common negative.
- 4 - Line voltage maintained at 117 volts for voltage readings.
- 5 - Nominal tolerance on component values makes possible a variation of ± 15% in voltage and resistance readings.
- 6 - Volume control at maximum, no signal applied for voltage measurements.

STAGE GAIN MEASUREMENTS

ANTENNA TO RF GRID	2X	600ΩC
RF GRID TO CONV. GRID	2X	600ΩC
CONVERSION GAIN	15X	IN 600ΩC OUT 45ΩC
INPUT IF TRANSFORMER	1.5X	455ΩC
1st IF TUBE	175X	455ΩC
INTER IF TRANS.	.1X	455ΩC
2nd IF TUBE	200X	455ΩC
OUTPUT IF TRANS.	.5X	455ΩC
AUDIO	35X	400 Ω
OUTPUT	28X	400 Ω

The stage gain measured values listed above are approximate values for an average operative stage, rather than an absolute value. It should be borne in mind that it is possible to introduce so many variables into the measurement operation, such as, type of equipment used for measuring, handling and placement of probes, the accuracy of alignment, etc., that an absolute reading is impractical. AVC is made inoperative by connecting negative (-) 3 volts to the AVC line.

ALIGNMENT INSTRUCTIONS—READ CAREFULLY BEFORE ATTEMPTING ALIGNMENT

Set all controls as follows except where noted otherwise: "Crystal-phasing" to zero, "Sensitivity" at maximum, "Reception" to "AM-NFC", "Selectivity" to "Normal-Sharp", "Volume" at maximum, "CW Pitch" to zero, Tone switch to "High", Standby-Receive switch to "Receive" and Noise Limiter to "Off". Set bandspread tuning cap. fully open at all times with exception of Bands 5 & 6 where it only is used for tuning. Use insulated alignment screwdriver for all adjustments.

10.7 MC IF ALIGNMENT USING AM SIGNAL GENERATOR AND VTVM

DUMMY ANTENNA	SIGNAL GENERATOR COUPLING	SIGNAL GENERATOR FREQUENCY	BAND SWITCH POS.	RADIO DIAL SETTING	CONNECT VTVM	ADJUST	REMARKS
1 Direct	High side to rear stator of center section of bandspread tuning cap.	10.7MC (Unmodulated)	Band "5"	50 on logging scale.	DC probe to Point ⑤, Common to ground.	A1, A2, A3, A4, A5, A6, A7	Turn reception switch to "FM" and adjust for maximum deflection.
2					DC probe to Point ⑥, Common to ground.	A8	Adjust for zero deflection. Continue with AM alignment in Step 5.

10.7 MC IF ALIGNMENT USING FM SIGNAL GENERATOR AND OSCILLOSCOPE

Use freq. modulated signal with 60% modulation and 450KC sweep. Use 120V sawtooth voltage in scope for horizontal deflection.

DUMMY ANTENNA	SIGNAL GENERATOR COUPLING	SIGNAL GENERATOR FREQUENCY	BAND SWITCH POS.	RADIO DIAL SETTING	SCOPE CONNECT	ADJUST	REMARKS
1 .05 MFD	High side to Pin 4 (grid) of 6BH7 2nd IF tube (4). Low side to chassis.	10.7MC (Freq. Mod.)	Band "5"	50 on logging scale.	Vertical input in series with .05 MFD cap. to Point ④, Low side to chassis.	A2, A3	Turn reception switch to FM and adjust for maximum amplitude, symmetry and coincidence of pattern per Fig. 1.
2 .05 MFD	High side to Pin 4 (grid) of 6BQ7					A4, A5	
3 .05 MFD	High side to rear stator of center section of bandspread tuning cap.					A6, A7	
4 .05 MFD	High side to Pin 4 (grid) of 6BH7 2nd IF Tube (4). Low side to chassis.				Vertical input to Point ④, Ground to chassis.	A1, A8	Alternately adjust A1 for maximum amplitude and A8 for maximum straightness of crossover lines with crossover occurring at center of pattern per Fig. 2. Continue with AM Alignment in Step 5.

AM IF ALIGNMENT

In Steps 5, 6, 7 and 8 set sig. gen. to exact crystal frequency as follows: Set sig. gen. to approximately 455KC. Turn SFD on and set CW pitch for approximately a 1000V note. Set selectivity control to "Crystal-Sharp" and tune sig. gen. to weakest of the two response frequencies on either side of zero beat. Adjust "Crystal-Phasing" control for minimum audio output. Return sig. gen. for maximum output on the opposite side of zero beat.

DUMMY ANTENNA	SIGNAL GENERATOR COUPLING	SIGNAL GENERATOR FREQUENCY	BAND SWITCH POS.	RADIO DIAL SETTING	OUTPUT METER	ADJUST	REMARKS
5 Direct	High side to rear stator of center section of tuning cap. Low side to chassis.	455KC (See pre-alignment notes)	Band "4"	50 on logging scale.	Across voice coil	A9, A10, A11, A12, A13	Turn selectivity switch to normal sharp and adjust A9, A10, A11, A12 and A13 for maximum output.
6 Direct						A14	Turn selectivity switch to "Crystal-Broad". Adjust A14 for maximum output.
7 Direct						A15	Turn selectivity switch to "Normal-Sharp". Adjust A15 for maximum output.
8 Direct						A16	Turn reception switch to "CW". Remove CW pitch control knob and adjust A16 for zero beat. Replace knob with zero at index line. Repeat 10.7 MC IF alignment to insure that they have not been detuned in the process of aligning 455KC IF.
9 Direct		10.7MC	Band "5"			A17	Adjust for maximum output. Tune sig. gen. to 11.81MC if signal is not heard return sig. gen. to 10.7 MC and adjust A17 counter-clockwise to next peak. Adjust for maximum output and recheck for image. Reassemble receiver in cabinet.

RF ALIGNMENT

RF4 Dummy consists of 200 MFD cap. in series with 20 microhenry choke with choke shunted by a 400 MFD cap. in series with a 400Ω carbon resistor.

DUMMY ANTENNA	SIGNAL GENERATOR COUPLING	SIGNAL GENERATOR FREQUENCY	BAND SWITCH POS.	RADIO DIAL SETTING	OUTPUT METER	ADJUST	REMARKS
10 RFA Dummy (see prealignment notes)	High side to ant. terminal "A1". Low side to "A2" with "A2" grounded.	1500KC	Band 1	1500KC	Across voice coil	A18, A19, A20	Adjust for maximum output in order given.
11	"	800KC	"	800KC	"	A21	Adjust for maximum output in order given. Repeat Steps 10 & 11 until no further improvement can be made.
12	"	4.5MC	Band 2	4.5MC	"	A22, A23, A24	Adjust for maximum output in order given.
13	"	2MC	"	2MC	"	A25	Adjust for maximum output in order given. Repeat Steps 12 & 13 until no further improvement can be made.
14 330Ω carbon res.	"	14MC	Band 3	14MC	"	A26	Adjust for maximum output.
15	"	"	"	Tune for maximum output.	"	A27, A28	Rock tuning cap. and adjust for maximum output.
16	"	6MC	"	6MC	"	A29	Adjust for maximum output.
17	"	"	"	Tune for maximum output.	"	A30, A31	Rock tuning cap. and adjust for maximum output. Repeat Steps 14 thru 17 until no further improvement can be made.
18	"	14MC	Band 3A	Main tuning dial at 20 meter band marker. Band spread at 14MC.	"	A32	Adjust for maximum output.
19	"	14.2MC	"	Main tuning dial at 20 meter band marker. Band spread tuned maximum output.	"	A33, A34	Rock tuning cap. and adjust for maximum output.
20	"	36MC	Band 4	36MC	"	A35	Adjust for maximum output. Tune sig. gen. to 35.1MC. If signal is not heard, retune sig. gen. to 36MC and close A35 to next peak. Adjust for maximum output and recheck for image.
21	"	"	"	Tune for maximum output.	"	A36, A37	Rock tuning cap. and adjust for maximum output.
22	"	18MC	"	18MC	"	A38	Adjust for maximum output.
23	"	"	"	Tune for maximum output.	"	A39, A40	Rock tuning cap. and adjust for maximum output. Repeat Steps 20 thru 23 until no further improvement can be made.
24	"	54MC	Band 5	54MC (On band-spread dial)	"	A41	Adjust for maximum output.
25	"	"	"	Tune for maximum output.	"	A42, A43	Rock tuning cap. and adjust for maximum output.
26	"	46MC	"	46MC	"	A44	Adjust for maximum output.
27	"	"	"	Tune for maximum output.	"	A45, A46	Rock tuning cap. and adjust for maximum output. Repeat Steps 24 thru 27 until no further improvement can be made.
28	"	"	"	44.6MC (See remarks)	"	A17	Tune for fourth harmonic of the second oscillator at approx. 44.6MC. If signal is not heard A17 is adjusted to the image frequency and Step 9 must be repeated.
CONNECT VTVM							
29 330Ω carbon res.	High side to out. terminal "A1". Low side to "A2" with "A2" grounded	106MC	Band 6	106MC	DC probe to Point Ⓞ. Common to chassis	A47	Adjust for maximum deflection.
30	"	"	"	Tune for maximum deflection.	"	A48, A49	Rock tuning cap. and adjust for maximum deflection.
31	"	89MC	"	89MC	"	A50	Adjust for maximum deflection.
32	"	"	"	Tune for maximum deflection.	"	A51, A52	Rock tuning cap. and adjust for maximum deflection. Repeat Steps 29 thru 32 until no further improvement can be made.

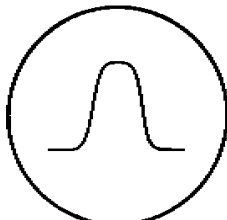

FIG. 1

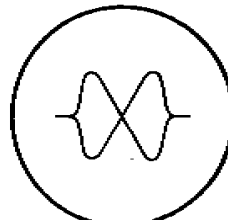
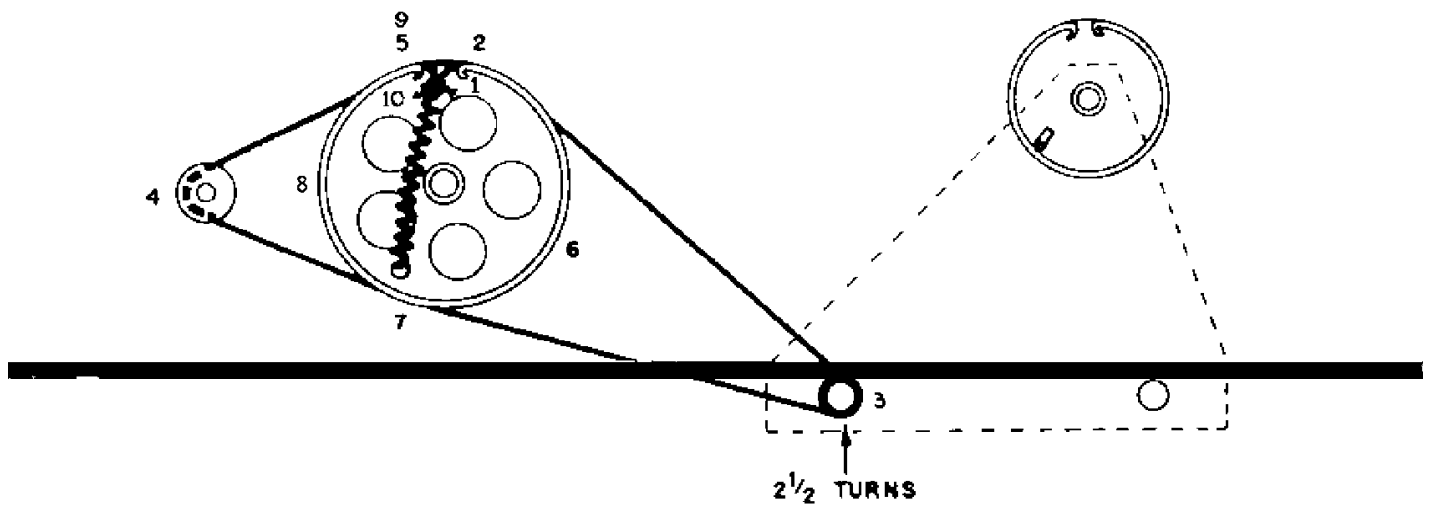
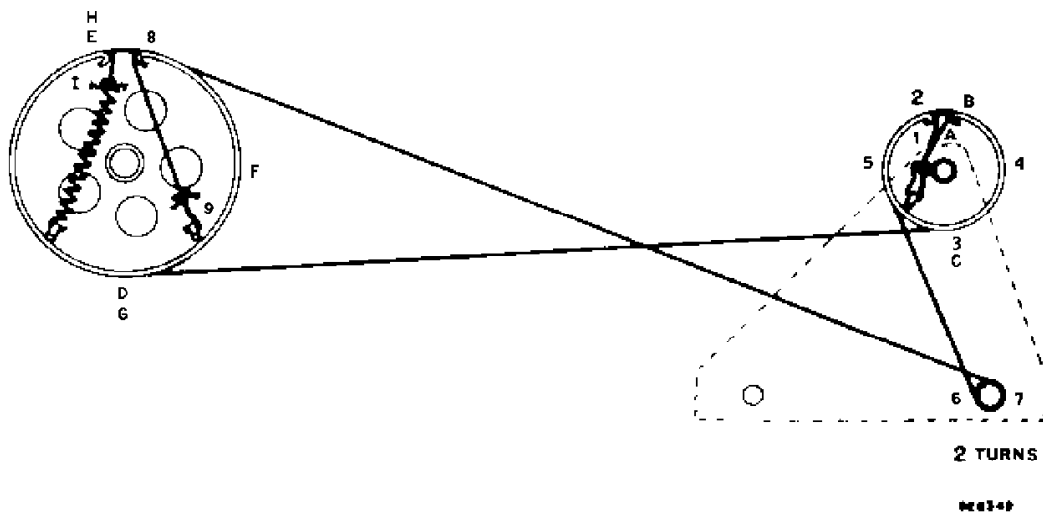

FIG. 2



928348

Fig. 1. Dial cable stringing, general coverage dial



928349

Fig. 2. Dial cable stringing, band spread dial.

the hallicrafters co.

SERVICE BULLETIN FOR MODEL SX-43

GENERAL

Tubes	Ten plus rectifier
Speaker Output	500/5000 Ohms.
Headset Output	Low impedance.
Antenna Input	For 75 to 600-ohm line or single wire lead-in.
Phone Output	High impedance.
External Power Connector	Std. octal socket.
Tuning Range	Band 1. 140 kc - 1700 kc. AM. 2. 1.7 mc - 5 mc. AM. 3. 8 mc - 16 mc. AM. 3A. 14 mc - 14.4 mc. AM. 4. 15.5 mc - 44 mc. AM. 5. 44 mc - 55 mc. AM, FM 6. 86 mc - 109 mc. FM
Intermediate Frequency	455 kc/1.5 mc.
Power Supply	105-125 V. 50/60 cycles AC.
Power Consumption	20 Watts.

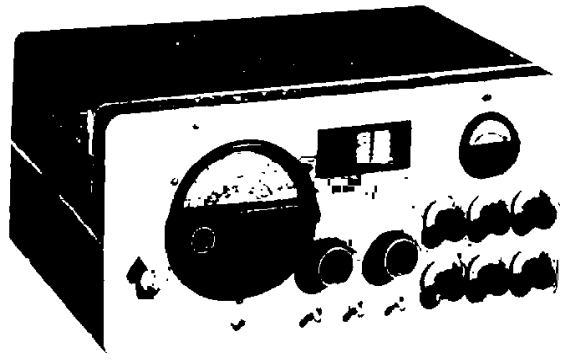

92X721

CARRIER LEVEL METER ADJUSTMENT

1. Connect a jumper between the two antenna terminals and ground.
2. Set front panel controls as follows:
 - SENSITIVITY - Maximum.
 - RECEPTION - AM/AVC.
 - SELECTIVITY - NORMAL/SHARP.
 - BAND SELECTOR - 4.
 - VOLUME - Maximum. (No signal should be heard.)
3. Set "S" METER ADJ. (See Fig. 3.) on rear chassis apron for zero on the CARRIER LEVEL meter.

POSITIONING CONTROL KNOBS

- BAND SELECTOR - As required by markings.
- RECEPTION - As required by markings.
- SELECTIVITY - As required by markings.
- SENSITIVITY - Zero at full counter clockwise rotation.
- VOLUME - Zero at full counter clockwise rotation.
- CW PITCH - See alignment chart.
- CRYSTAL PHASING - Zero with plates half meshed.

RESTRINGING DIAL CORD

Two separate dial drive mechanisms are used: one for the general coverage dial and one for the band spread dial. The stringing sequence for each is shown in Figs. 1. and 2. by a series of number and letters. Use 30 lb. test dial cord. Approximately 51 inches of cord will be required for the bandspread dial drive and about 26 inches for the general coverage dial drive. Note that the cording procedure for the bandspread dial starts with a knotted loop at the driving pulley and is threaded to the driven pulley via two routes, the numbered 1-5 (approximately 24 inches long) and the other lettered A to I (approximately 27 inches long). In production the short, numbered route string is threaded through first in the bandspread drive.

REPLACING LAMPS

The two dial lamps and meter lamp are accessible through the hinged cabinet cover. Remove two screws holding the metal light shield to expose the dial lamps. Replace these with 6-8 V. 250 MA. GE. #44 (Blue bead) or equivalent. The carrier level meter lamp is made accessible by removing the four screws holding the protective cover located directly behind the meter. Replace this lamp with a 6-8 V. 150 MA. GE. #40 (Brown bead) or equivalent. Do not use a 250 MA. lamp in the meter housing as the excessive heat will discolor the meter scale.

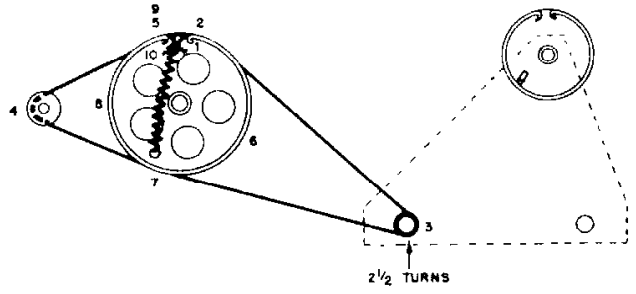

92B344

Fig. 1. Dial cable stringing, general coverage dial

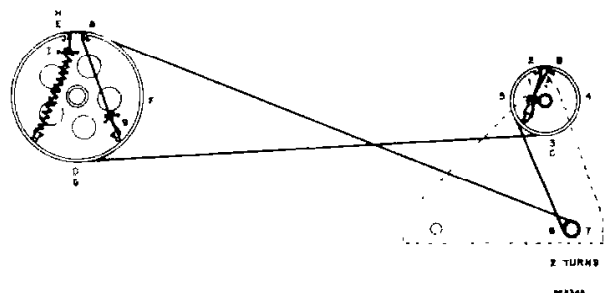

92B344

Fig. 2. Dial cable stringing, band spread dial.

ALIGNMENT PROCEDURE

It will be necessary to remove the receiver chassis from the cabinet to make alignment adjustments on the i-f stages. The r-f stages receive final alignment through the holes in the bottom of the cabinet to compensate for the close proximity of the cabinet to the r-f coils. The chassis is held in the cabinet by seven screws along the edge of the flange of the front panel and by three screws through the bottom of the cabinet along the rear edge:

The standard RMA dummy antenna specified in the alignment chart consists of a 200 mmf condenser in

series with a 20 uh r-f choke which is shunted by a 400 mmf condenser in series with a 400 ohm carbon resistor.

The following control settings are to be set before alignment:

tone Switch	- HIGH
STANDBY-RECEIVE	- RECEIVE
NOISE LIMITER	- OFF
VOLUME	- Max. gain
SENSITIVITY	- Max. sensitivity
Band Spread Dial	- High frequency stop

ALIGNMENT CHART

Step	Dummy Antenna	Signal Generator Coupling	Signal Generator Frequency	Receiver Control Settings	Receiver Dial Setting	Adjust	Remarks
1	None	Connect to center section (rear stator plates) of low capacity gang.	10.7 mc (No modulation)	BAND SEL.-5 REC. sw.-FM	General coverage dial at mid-scale	S1, S2, S3, S4, S5, S6, S7	Adjust for max. D.C. voltage as measured between pin #7 of the 6AL5 and ground with a V.T. voltmeter.
2	None	See step 1.	10.7 mc (No modulation)	See Step 1	See step 1.	S8	Adjust for zero D.C. voltage as measured between junction of R-50 and C-83 and ground with a V.T. voltmeter.
3	None	See step 1.	455 kc **	BAND SEL.-4 REC. sw.-AM-MVC SEL. sw.-NORMAL-SHARP	See step 1.	S9, S10, S12, S13, S14	Adjust for max. audio output.
4	None	See step 1.	455 kc **	BAND SEL.-4 REC. sw.-AM-MVC SEL. sw.-CRYSTAL-BROAD	See step 1.	S11	Adjust for max. audio output.
5	None	See step 1.	455 kc **	BAND SEL.-4 REC. sw.-AM-MVC SEL. sw.-NORMAL-SHARP	See step 1.	A	Adjust for max. audio output.
[REDACTED SECTION]							
8E	None	See step 1.	10.7 mc	BAND SEL.-5 REC. sw.-AM-MVC SEL. sw.-NORMAL-SHARP	See step 1.	S15*	Tune slug S15 to high freq. side of 10.7 mc (11.155 mc). Tune for max. audio output.
9	Std. RMA dummy	To terminals A1 and A6 with jumper between A2 and GND.	1500 kc	BAND SEL.-1 REC. sw.-AM-MVC SEL. sw.-NORMAL-SHARP	1500 kc	B*, C, D	Adjust for max. audio output.
10	Std. RMA dummy	See step 9.	600 kc 4.5 mc 2 mc	BAND SEL.-2 REC. sw.-AM-MVC SEL. sw.-NORMAL-SHARP	600 kc 4.5 mc 2 mc	E* F*, G, H S16*	Adjust for max. audio output.
11	330-ohm carbon res.	See step 9.	14 mc *** 6 mc ***	BAND SEL.-3 REC. sw.-AM-MVC SEL. sw.-NORMAL-SHARP	14 mc 6 mc	I*, J, K S17*, S18 S19	Adjust for max. audio output.
12	330-ohm carbon res.	See step 9.	14 mc	BAND SEL.-3A REC. sw.-AM-MVC SEL. sw.-NORMAL-SHARP	M.T. dial at 20M. band line B.S. dial at 14 mc	L*	Adjust for calibration. Check band spread calibration and reset trimmer L if necessary. Increase trimmer cap. to decrease bandspread etc.

* Note - Calibration adjustment.

** Note - Set generator frequency to exact crystal freq. as follows: Turn on BFO and set CW PITCH for approx. 1000 cycles with signal generator set at approx. 455 kc. Set SELECTIVITY control at CRYSTAL-SHARP and tune signal generator for weakest of two response frequencies on either side of zero beat; adjust CRYSTAL PHASING control for complete null; retune signal generator for maximum output on opposite side of zero beat for the exact IF alignment frequency.

*** Note - Rock signal generator when making adjustments.

Note - Step 8. adjusts the 11.155 mc oscillator for the dual conversion channel required for AM reception on band 5. After aligning band 5 in step 15, tune to approx. 44.6 mc and pick up fourth harmonic of the oscillator. If the oscillator harmonic falls at approx. 51.3 mcs, the oscillator is oscillating at the low frequency side or image frequency and must be readjusted.

ALIGNMENT CHART - Continued

Dummy	Signal Generator	Signal Generator	Receiver Control	Receiver Dial	Receiver	Notes	
				dial at 14.2 mc.			
14	330-ohm carbon res.	See step 9	36 mc***	BAND SEL.-4 REC. sw.-AM-MVC SEL. sw.-NORMAL-SHARP	36 mc	O*, P, Q	Adjust for max. audio output. Osc. falls on low freq. side of signal.
			18 mc***		18 mc	S20*, S21, S22	
15	330-ohm carbon res.	See step 9	54 mc ***	BAND SEL.-5 REC. sw.-AM-MVC SEL. sw.-NORMAL-SHARP	54 mc	R*, S, T	Adjust for max. audio output
			46 mc ***		46 mc	S23*, S24, S25	
16	330-ohm carbon res.	See step 9	106 mc ***	BAND SEL.-6 REC. sw.-AM-MVC SEL. sw.-NORMAL-SHARP	106 mc	U*, V, W,	See step 1.
			89 mc ***		89 mc	S26*, S27, S28	

For footnotes - see previous page.

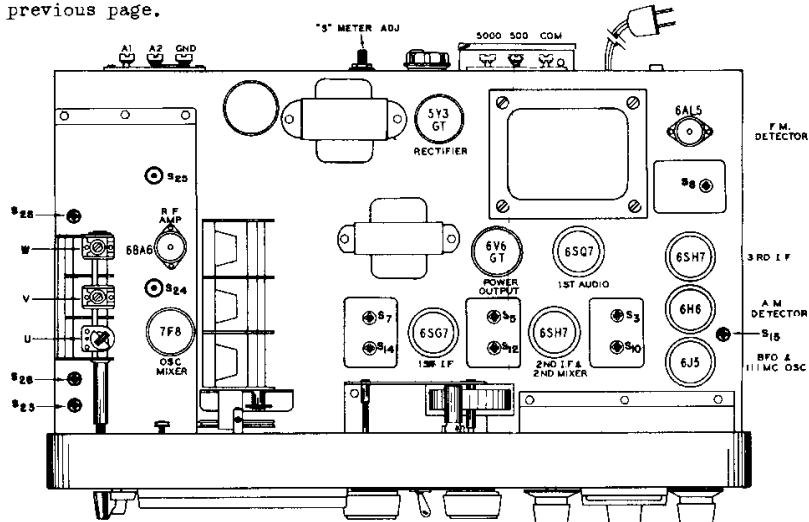

Fig. 3. Alignment adjustments, top view.

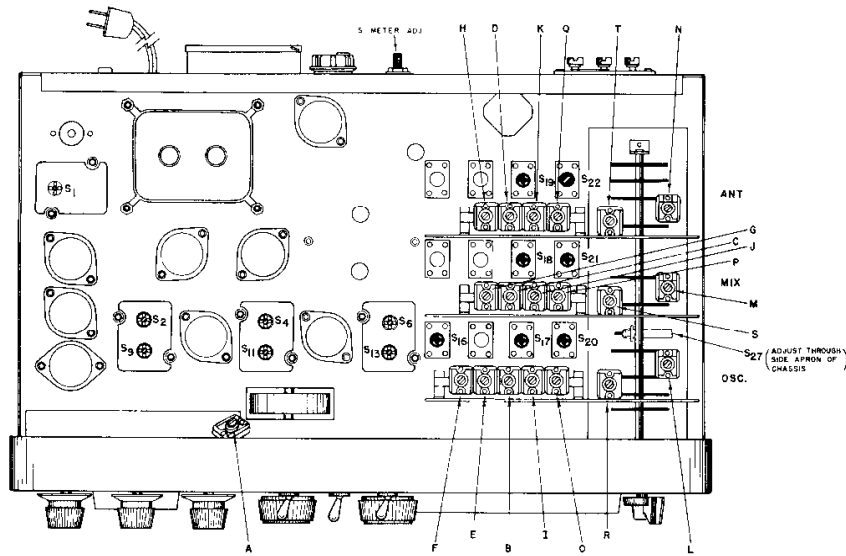

Fig. 4. Alignment adjustments, bottom view.

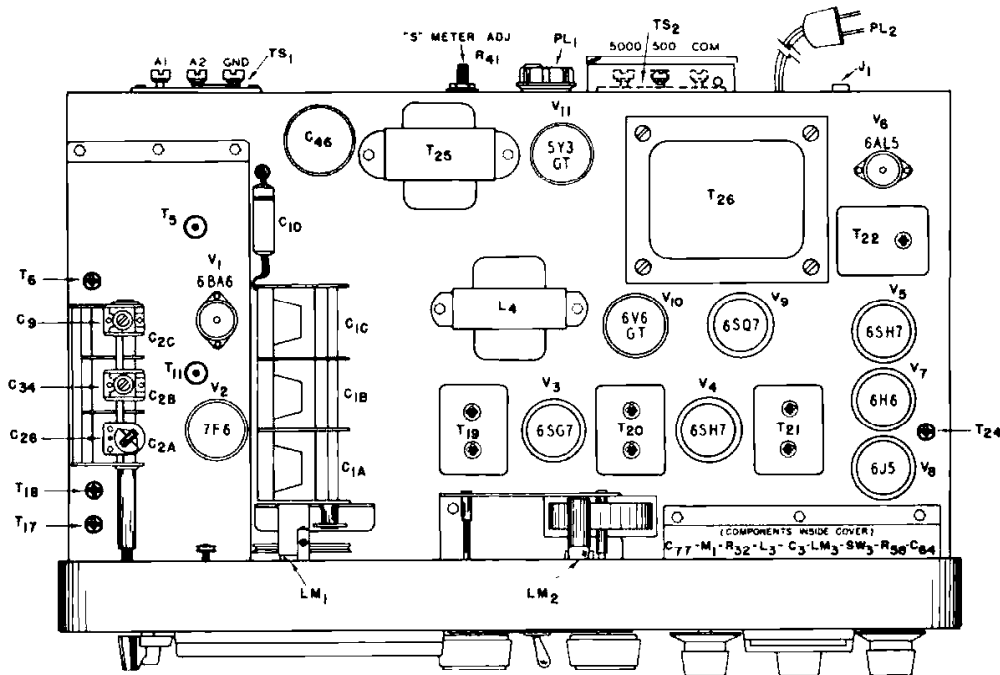

Fig. 5. Component location, top view.

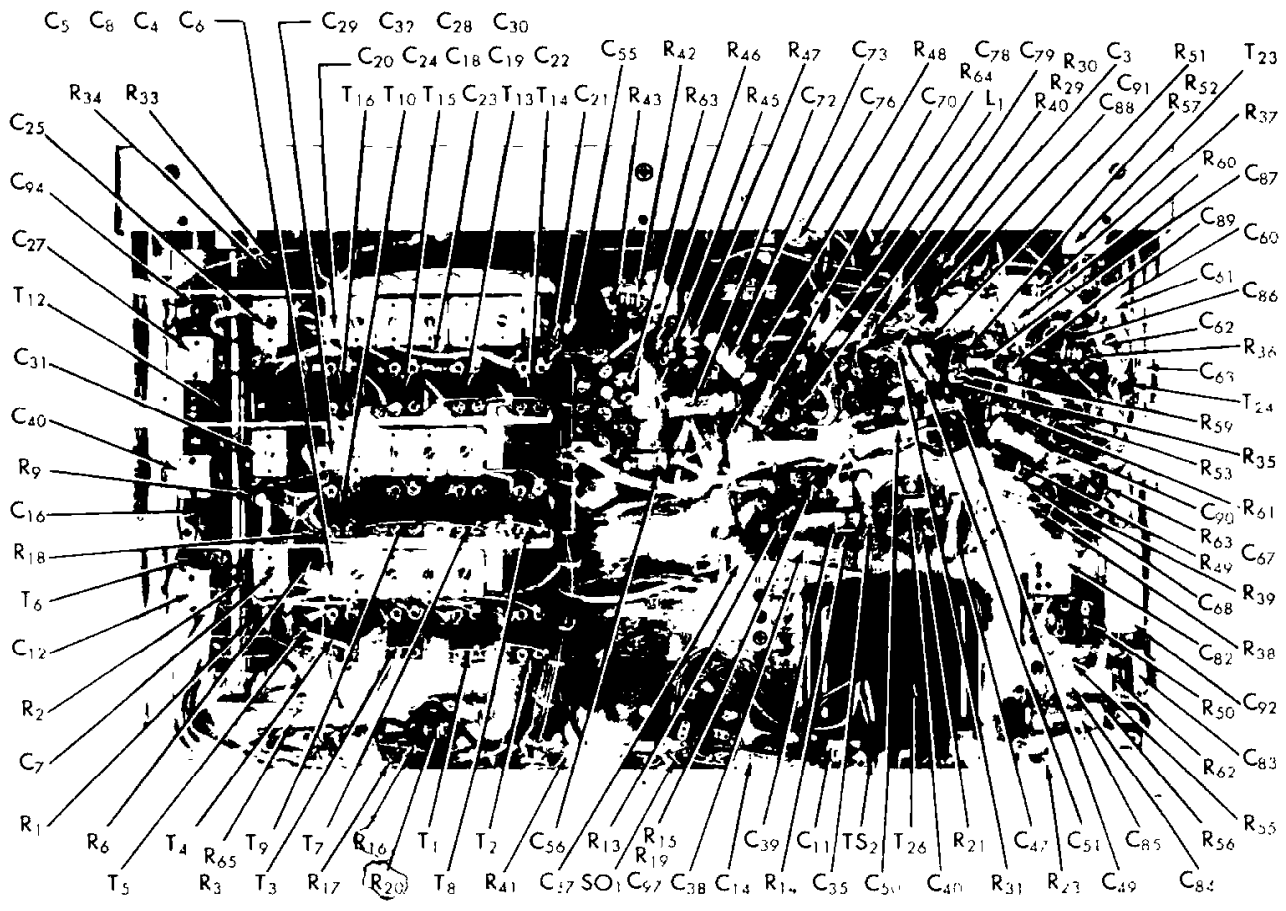

Fig. 6. Component location, bottom view.

SERVICE PARTS LIST

REF. NO.	DESCRIPTION	HALLICRAFTER'S PART NUMBER
CAPACITORS		
C-1	Capacitor, general coverage	48C174
C-2	Capacitor, band spread	48C173
C-3, 39, 48, 89	.02 mfd 400 V., tubular paper	46AW203J
C-4, 5, 6, 8, 28, 29, 30, 32	Capacitor, trimmer strip assy.	44B199
C-7, 25, 31	Capacitor, trimmer, 4-50 mmf	44A200
C-9, 12, 27, 34, 96, 76, 96	Capacitor, trimmer, 2-30 mmf	44A047
C-10	.05 mfd 200 V., tubular paper	46A091

C-15, 16, 52	1500 mmf 350 V., ceramic	47A161
C-17, 33	25 mmf 500 V., ceramic	47A141
C-18, 19, 20, 22, 24	Capacitor, trimmer strip assy.	44B197

C-36	.02 mfd 600 V., tubular paper	46AY203J
C-37	10 mfd 25 V., electrolytic	42A033
C-38	.05 mfd 600 V., tubular paper	46AY503J
C-40, 45, 61, 87, 88, 97	100 mmf 500 V., ceramic	CC25UK101K
C-41	Capacitor, T.C.	44A158
C-42	220 mmf 500 V., mica	CM20B221K
C-43	51 mmf 500 V., ceramic	CC20UK510K
C-46	60-20-20 mfd 450 V., electrolytic	45B113
C-47, 67, 91, 95	.005 mfd 450 V., ceramic	47A168
C-49, 51, 55, 56, 64, 70, 73	.01 mfd 600 V., tubular paper	46A2103J
C-50, 72, 84, 85, 90	.05 mfd 200 V., tubular paper	46AU503J

C-80	820 mmf 500 V., mica	CM25AB21K
C-82, 83	1000 mmf 500 V., mica	CM20A102K
C-86	2.2 mfd 500 V., ceramic	47A160-4
C-92	.25 mfd 400 V., tubular paper	46AV254J
C-94	15 mmf 500 V., ceramic	CC20UK150K

RESISTORS

R-1, 10	47 ohms 1/2 watt, carbon	RC20AE470K
R-2	27 ohms 1/2 watt, carbon	RC20AE270K
R-3, 38, 54, 59, 61	1 meg-ohm 1/2 watt, carbon	RC20AE105K
R-4, 9	6 ohms 1/2 watt, carbon	23A011
R-5	68 ohms 1/2 watt, carbon	RC20AE680K
R-6, 47	15,000 ohms 2 watts, carbon	RC40AE153K
R-7, 46	27,000 ohms 1 watt, carbon	RC30AE273K
R-8	33 ohms 1/2 watt, carbon	RC20AE330K
R-11, 16	1000 ohms 1 watt, carbon	RC30AE102K
R-12	100 ohms 1 watt, carbon	RC30AE101M
R-13, 23	470,000 ohms 1/2 watt, carbon	RC20AE474K
R-14, 31	33,000 ohms 1 watt, carbon	RC30AE333K
R-15	270 ohms 1 watt, carbon	RC30AE271K
R-17, 26, 34	1000 ohms 1/2 watt, carbon	RC20AE102K
R-18, 29, 58	150 ohms 1/2 watt, carbon	RC20AE151K
R-19, 39	220,000 ohms 1/2 watt, carbon	RC20AE224K
R-20	4700 ohms 1 watt, carbon	RC30AE472K
R-21	15 megohms 1/2 watt, carbon	RC20AE156K
R-22	Resistor, variable, VOLUME control	25B601
R-24	15 ohms 1/2 watt, carbon	RC20AE150K
R-25, 42	22,000 ohms 1/2 watt, carbon	RC20AE223K
R-27	10,000 ohms 1 watt, carbon	RC30AE103K
R-28, 52	2.2 megohms 1/2 watt, carbon	RC20AE225K
R-29, 58, 62	150 ohms 1/2 watt, carbon	RC20AE151K
R-30	680 ohms 1/2 watt, carbon	RC20AE681K
R-32	Resistor, variable, SENSITIVITY control	25B577
R-33	10 ohms 1/2 watt, carbon	RC20AE100K
R-35, 48	3300 ohms 1/2 watt, carbon	RC20AE332K
R-36	47,000 ohms 1/2 watt, carbon	RC20AE473K
R-37	15,000 ohms 1 watt, carbon	RC30AE153K
R-40, 45	82 ohms 1/2 watt, carbon	RC20AE820K
R-41	Resistor, variable, "S" meter control	25C022
R-43	47,000 ohms 1 watt, carbon	RC30AE473K
R-49	100,000 ohms 1 watt, carbon	RC30AE104K
R-50, 51, 55, 56	100,000 ohms 1/2 watt, carbon	RC20AE104K
R-53, 65	6.8 megohms 1/2 watt, carbon	RC20AE685M
R-57	82,000 ohms 1/2 watt, carbon	RC20AE823K
R-60	250,000 ohms 1/2 watt, carbon	RC20AE254K
R-62, 63	6.8 ohms 1 watt, carbon	RC30AE068K
R-64	680,000 ohms 1/2 watt, carbon	RC20AE684M

SERVICE PARTS LIST (Continued)

REF NO	DESCRIPTION	HALLICRAFTER'S PART NUMBER
COILS AND TRANSFORMERS		
L-1	R-F choke, special	53A108
L-2	R-F choke, special	53B009
L-3	R-F choke, 540 uh	53A107
L-4	Filter choke, 11 h. 75 ma.	56B067
T-1	Transformer, antenna, band 1	518928
T-2	Transformer, antenna, band 2	518927
T-3	Transformer, antenna, band 3	518926
T-4	Transformer, antenna, band 4	518925
T-5	Transformer, antenna, band 5	518924

T-8	Transformer, mixer, band 2	518932
T-9	Transformer, mixer, band 3	518933
T-10	Transformer, mixer, band 4	518931
T-11	Transformer, mixer, band 5	518930

T-15	Transformer, oscillator, band 3	518937
T-16	Transformer, oscillator, band 4	518936
T-17	Transformer, oscillator, band 5	518935
T-18	Transformer, oscillator, band 6	518941
T-19	Transformer, 1st I-F	50C212
T-20	Transformer, 2nd I-F	50C213
T-21	Transformer, 3rd I-F	50C214
T-22	Transformer, F-M detector	50C208
T-23	Transformer, B.F.O.	54B033-1
T-24	Transformer, oscillator, 11 mc.	5189B4
T-25	Transformer, output	55B095
T-26	Transformer, power, 105-125V. 60 cycles	52C143
T-26*	Transformer, power 115/130/150/200/250 V., 25/60 cycles	52C142

V-3	Tube, type 6807	90X687
V-4, 5	Tube, type 6SH7	90X65H7
V-6	Tube, type 6AL5	90X6AL5
V-7	Tube, type 6H6	90X6H6
V-8	Tube, type 6J5	90X6J5
V-9	Tube, type 6SQ7	90X6SQ7
V-10	Tube, type 6V6GT	90X6V6GT
V-11	Tube, type 5Y3GT/G	90X5Y3GT
LM-1, 2	Lamp, dial illumination, 6-8 V. 250 ma. G.E. #44	39A003
LM-3	Lamp, meter illumination, 6-8 V. 150 ma. G.E. #47	39A004

SWITCHES

SW-1	Switch assembly, BAND SELECTOR	60C261
SW-2	Switch assembly, SELECTIVITY	60B263
SW-3	Switch assembly, RECEPTION	60B262
SW-4, 5, 6	Switch, toggle, SPST	60A138
SW-7	Switch, power, part of R-22	

PLUGS AND SOCKETS

PL-1	Plug, octal, jumpers for a-c operation	35A003
PL-2	Plug and cord assy., a-c power	87A078
J-1	Jack, phono input	36A029
J-2	Jack, headphones	36A036
	Socket, octal (Tube & SO-1)	6A035
	Socket, miniature, tube	6A193
	Socket, loctal, tube	6A223
	Socket, pilot lamp, dial	86B050
	Socket, pilot lamp, meter	6A262

MISCELLANEOUS COMPONENTS

M-1	Meter, carrier level	82B125
	Knob, TUNING and BANDSPREAD	15A048
	Knob, CW PITCH	15A089
	Knob, BAND SELECTOR	158088-1
	Knob, RECEPTION	15A094
	Knob, SELECTIVITY	15A095
	Knob, VOLUME and SENSITIVITY	15A097
	Knob, CRYSTAL PHASING	15A087
X-1	Crystal, 455KC	19A123
TS-1, TS-2	Terminal strip, antenna or speaker	88A567
	Screw, knurled (For TS-1 or TS-2)	3A1371
	Cover, speaker terminals	69B173

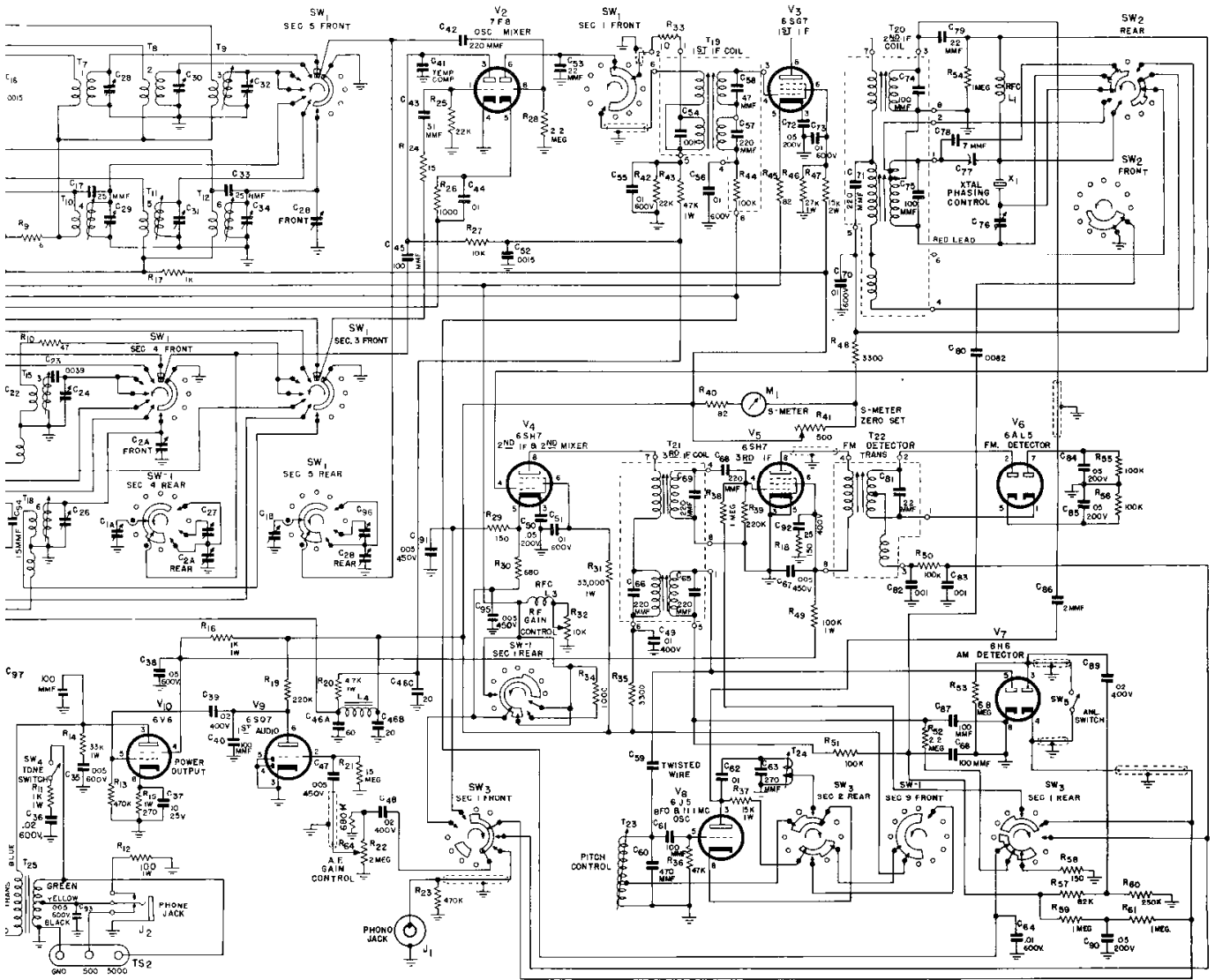

890226-F

Fig. 8. Schematic diagram.

