

The main tuning dial, which appears behind the large escutcheon, is accurately calibrated in kilocycles on band #1 and in megacycles on the remaining four bands.

Note: The accuracy of the main dial calibration will hold only if the BAND SPREAD condenser is set at minimum capacity, or the position indicated by "0" on the Band Spread dial which has been approached by turning the Band Spread Knob in a clockwise direction, or to the right, as far as it will go.

When first using the receiver, become familiar with its operation on the standard broadcast band, or Band #1, before tuning the short wave bands. You then will be able to fully appreciate the capabilities of the Skyrider Defiant.

FREQUENCY METER TUNING

The band spread dial of the SX24 Model is calibrated so that the operator may determine quite closely the frequency of the signal to which he is listening on the 10 to 80 meter amateur bands inclusive. The outer edge of this dial is marked off in 100 divisions for additional ease in logging and locating stations.

Around the outer edge of the main tuning dial the amateur bands for which "Frequency Meter Tuning" is available are marked with the red numerals; 10 - 20 - 40 and 80. Set the red line beneath these numerals directly opposite the hair-line on the window and switch to the correct band. The band spread scale will indicate correct frequency within the limits of the accuracy of the setting and calibration.

Amateur Band	Set Band Switch at
80 Meter	Band 2
40 Meter	Band 3B
20 Meter	Band 3
10 Meter	Band 4

BAND 3B -- Special reference is called to this position of the Band Switch so that no confusion will be experienced. Band 3B is the same as Band 3 and is used in order to have the band spreading of the 40 meter band accomplished through approximately the same number of degrees on the Band Spread Scale as occupied by the other amateur bands for which calibration appears. When the Band Switch is placed in position 3B another section of the band spread condenser is paralleled in the circuit. Band 3 main scale calibration will read somewhat high when the Band Switch is set on 3B.

TUBE LINE-UP

6SK7	R.F. Amplifier	6F6	2nd audio output stage
6K8	1st Detector-Mixer H.F. Oscillator	6H6	Automatic Noise Limiter
6SK7	1st I.F. Amplifier	76	Beat Frequency Oscillator
6SK7	2nd I.F. Amplifier	80	Rectifier
6SQ7	2nd Detector, A.V.C. 1st stage of audio		

CONTROLS AND OPERATION

Reading from left to right the functions of the various identified controls will be described.

The "R.F. Gain" control adjusts the sensitivity of the receiver by varying the cathode bias on the R.F. and I.F. amplifiers. Maximum sensitivity will be obtained when this control is rotated as far as it will go to the right. When this has been done a switch will operate which lights the lamp behind the calibrated "S" meter to be described in greater detail later.

The "Band Switch" will allow selection of the frequency ranges through which the receiver tunes. As previously mentioned, Band 3B is to be used when band spreading the amateur 40 meter band.

The "Selectivity - A.V.C. Switch" provides a means of bringing the signal through varying conditions of interference.

When using the receiver for the reception of modulated or telephony signals it is advisable to

strong signals. The maximum selectivity of the receiver is obtainable with the selectivity switch in the "C.W. Xtal" position. The received signal will be considerably sharper and as a result more care should be exercised in tuning when the C.W. crystal is in the circuit. In conjunction with the crystal filter the PHASING control, when properly adjusted, will prove helpful in coping with conditions of extreme interference. Adjustment of this control for maximum rejection of the unwanted signal, or audio image, will allow true single-signal reception. With the Selectivity Switch in all other positions but C.W. xtal, the phasing control should be adjusted for maximum gain.

The "Phone-Xtal" positions are an intermediate step in selectivity between C.W. crystal and I.F. sharp. Phone signals must necessarily be accurately resonated when operating in the Phone Xtal position or side band attenuation will seemingly reduce the strength of the signal.

The "Main Tuning" control is for adjusting the main dial of the receiver to the desired frequency.

The "Tone-High Low" switch directly below the above control in the "High" position gives natural reproduction. In the "Low" position, the highs are cut off, a condition that will be helpful in receiving signals during certain types of interference.

The "Crystal Phasing" control has previously been described in its association with the C.W. xtal selectivity position.

The "Band Spread" knob allows smooth back-lash - free operation of the separate band spread condenser and dial.

The "A.N.L." or automatic noise limiter switch will effectively minimize ignition and similar types of interference which would be objectionable to short wave reception if such a limiting device were not available. Best results are obtained with the A.F. Gain control set near the minimum end.

The "A.F. Gain" control turns the receiver "off" and "on" as well as controlling the volume of output of the receiver.

The "Pitch Control" and its associated "BFO- OFF-ON" switch provide a beat note for the reception of C.W. signals. The Pitch Control, when the B.F.O. switch is in the "ON" position allows variation of the frequency of the resultant beat note to a pitch most pleasing to the listener.

The "Send-Receive" switch momentarily removes plate voltage from the tubes in the receiver so that the set can be made inoperative during stand-by periods.

Into the "Phone Jack" can be connected any type of high impedance fones, crystal or magnetic, because no direct current flows in the headphone circuit.

"S" METER

When the R.F. gain control is advanced until a switch is heard to operate, a light will appear behind the translucent scale of the meter itself. Only when this light is on will the meter indicate in "S" units. With the R.F. gain control backed off from maximum the meter is still in the circuit but will not indicate carrier level accurately. When so adjusted the meter can be used as a resonance indicator. On the rear apron of the chassis is the "S" meter adjustment screw. To set the "S" meter, disconnect the antenna and have the R.F. Gain Control on full and the selectivity switch in the "I.F. sharp A.V.C. on" position. Now, adjust this knurled knob until the meter reads zero. Reconnecting the antenna and tuning in a station will show its relative carrier intensity.

The 500 and 5000 ohm terminals are for connections to a loud speaker or other load of those impedance values. The matching SX23 speaker should be connected to the 5000 ohm strip. When headphones are plugged into the phone jack the 5000 ohm speaker connection is automatically disconnected.

The "Ext. Switch" terminal strip is for external switch provisions should the receiver be controlled by a remote switch or relay. The Send-Rec switch on the panel must be in the Send Position when an external relay is used for stand-by operation.

Unless otherwise specified the SX24 Receiver operates on 100-125 volt 50-60 cycle current. A universal model is available on special order for operation on 110-250 volt, 25-60 cycle current, at a slight increase in price.

The Model SX24 Receiver draws 70 watts at 115 volts 60 cycle alternating current.

The Hallicrafters, Inc., reserve the right to make changes in design or to add improvements to instruments of their manufacture without incurring any obligation to install the same in any instrument previously purchased.

ALIGNMENT PROCEDURE

455 KC, Intermediate-Frequency Alignment.
 Have the controls set as follows:
 AF and RF gain controls for maximum volume.
 B.F.O. switch in the "ON" position.
 Set band switch to #2 band.
 Set main dial to 2 megacycles, band spread to zero.
 Selectivity switch in "CW Sharp" position.

Remove 6K8 grid cap and connect the hot side of your 455 KC generator to this tube. Connect the ground terminal of the signal generator to the chassis of the receiver. Now feed a 455 KC signal into the receiver and set the pitch control to give a beat note of approximately 1000 cycles. Adjust all I.F. transformer trimmers for maximum gain with the exception of the secondary trimmer on transformer T1. In adjusting this trimmer it will be noted that the output reaches a maximum goes through a dip and then back to maximum again. Wobulate the IF frequency and align to the dip between the two maximum points. A distinct change in the crystal note sounding like an apparent broadening of the crystal action will be noted when the correct adjustment has been reached. Now repeak carefully the other trimmers for maximum gain.

R. F. ALIGNMENT

Re-connect the grid cap to the 6K8 tube. Connect the hot side of the generator to the A₁ antenna terminal on the rear of the chassis. Be sure a jumper is connected to A₂ and G. Leave signal generator ground connected to the chassis of the receiver.

The location of the following trimmers and padders can be determined by referring to the top and bottom chassis views. All pad adjustments are for the low frequency end of each band while the trimmers are for the high frequency ends.

In order to get at the RF trimmers the guarantee card can be removed by placing a knife under the small snap fasteners holding it in place. So that most satisfactory adjustment of the trimmers and padders can be made, it is advisable to "Rock" the condenser gang across the signal being delivered by the generator until that particular circuit has been accurately peaked.

Bands	Trim at	Pad at
1	1400 KC Adjust C _A C _B C _C	600 KC Adjust Pad Band 1
2	4 MC Adjust C _D C _E C _F	2 MC Adjust Pad Band 2 (Top Chassis)
3	14 MC Adjust C _G C _H C _I	7 MC Adjust Pad Band 3
4	34 MC Adjust C _J C _K C _L	17 MC No pad on this Band

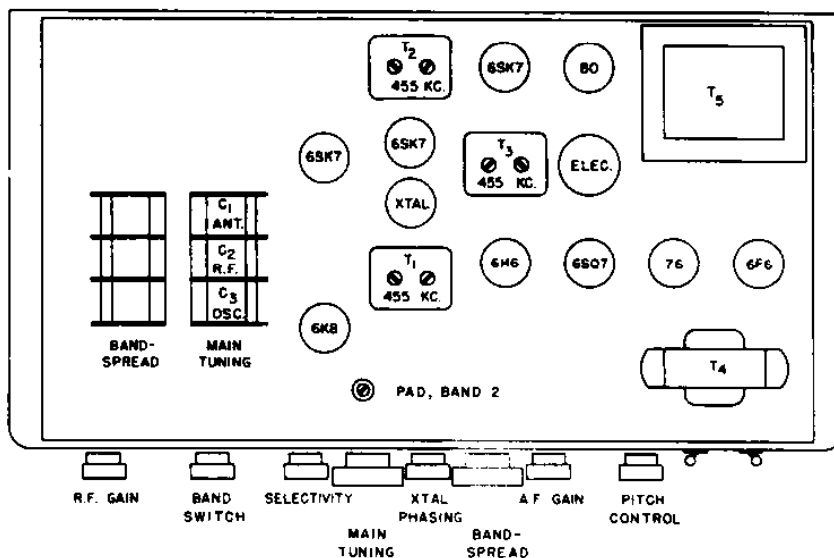
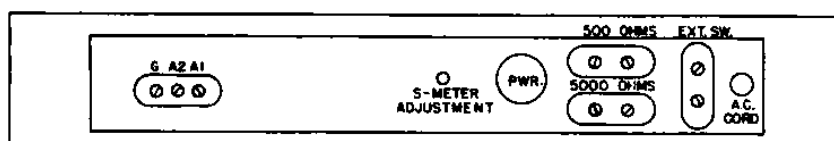
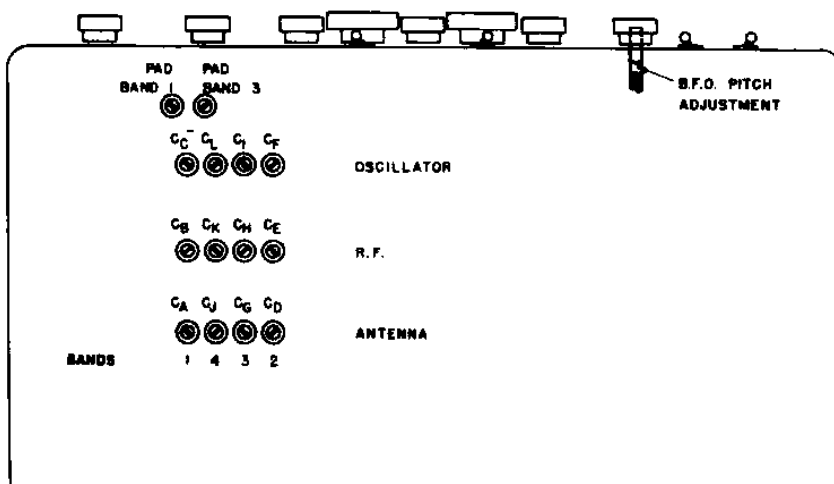

D C OPERATION

CONNECTIONS TO "PWR" SOCKET AFTER REMOVAL OF SHORTING PLUG

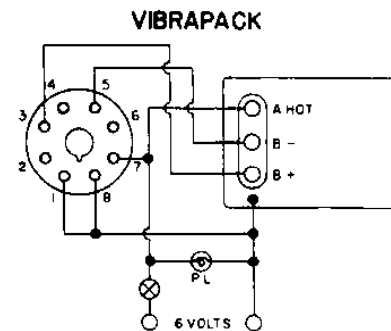

BATTERIES

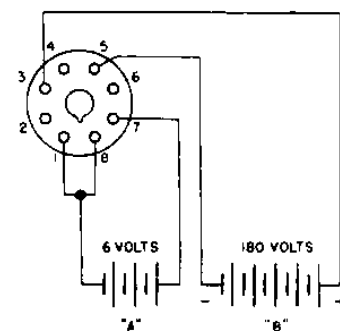

GUARANTEE

This receiver is guaranteed to be free from any defect in workmanship and material that may develop within a period of ninety (90) days from date of purchase, under the terms of the standard guarantee, as designated by the Radio Manufacturers Association. Any part or parts that prove defective within this period will be replaced without charge when subjected to examination at our factory, providing such defect, in our opinion, is due to faulty material or workmanship, and not caused by tampering, abuse or normal wear. All such adjustments to be made FOB the factory.

Should this receiver require any adjustments, your dealer or distributor has complete technical service in-

formation, or the factory will be glad to assist you in any problem direct.

Should it be necessary to return any part or parts to the factory, a "Return Material Permit" must be obtained in advance by first writing the Adjustment Department, who will issue due authorization under the terms of the guarantee.

The Hallicrafters, Inc., reserve the right to make changes in design or add improvements to instruments manufactured by them, without incurring any obligation to install the same in any instrument previously purchased.

All Hallicrafters receivers are built under patents of Radio Corporation of America and Hazeltine Corporation.

PARTS LIST
SKYRIDER DEFIANT MODEL SX24

RESISTORS

NO.	OHMS	WATTAGE	NO.	OHMS	WATTAGE
1	30	1/3	18	1,000,000	1/3
2	200	"	19	50,000	"
3	100,000	"	20	100	"
4	10,000	R.F. Gain Control	21	250,000	"
5	500	Variable	22	100,000	"
6	400	1/3	23	250,000	"
7	50,000	"	24	250,000	"
8	200	"	25	500	1
9	15,000	1	26	500,000	1/3
10	30,000	1	27	5,000	1
11	2,000,000	1/3	28	500,000	A.F. Gain Control
12	50,000	"	29	20,000	1
13	500,000	"	30	50,000	1/3
14	300	"	31	20,000	1
15	300	"	32	15,000	1
16	1,000	"	33	150	1/3
17	1,000,000	"	34	5,000	1

CONDENSERS

NO.	CAPACITY	VOLTAGE	TYPE	NO.	CAPACITY	VOLTAGE	TYPE
1	440 mmfd	Per Section		21	.005 mfd	600	Paper
2	4 "	" "		22	.01 "	400	"
3	26 "	" "		23	.02 "	600	"
4	.05 mfd	200	Paper	24	.02 "	200	"
5	25. mmfd		Ceramicon	25	.01 "	400	"
6	10. "		"	26	100. mmfd		Mica
7	.002 mfd		Mica	27	.01 mfd	600	Paper
8	.05 "	200	Paper	28	30. "	350	Electrolytic
9	.05 "	400	"	29	10. "	"	Electrolytic
10	25. mmfd	Crystal Phasing	Air	30	.1 "	400	Paper
11	.02 "	200	Paper	31	.05 "	200	"
12	.05 "	"	"	32	10. "	350	"
13	.05 "	"	"	33	100 mmfd		Mica
14	.02 "	400	"	34	105 "		Ceramicon
15	3. "	Twisted Pair		35	2200 "	Dual Pad	
16	100. "		Mica	36	450 "	"	
17	10. mfd	25	Electrolytic	37	1400 "	"	
18	50. mmfd		Mica	38	.002 mfd		Mica
19	.05 mfd	400	Paper	39	.05 "	400	Paper
20	10. "	25	Electrolytic	40	.0005 "		Mica
					.05 "	200	Paper

SWITCHES

SW1 - AC Switch On AF Gain	SW4 - A.N.L. on & OFF
SW2 - Send RC Switch	SW5 - Hi-Low Tone Switch
SW3 - B.F.O. on & OFF	SW6 - S-Meter

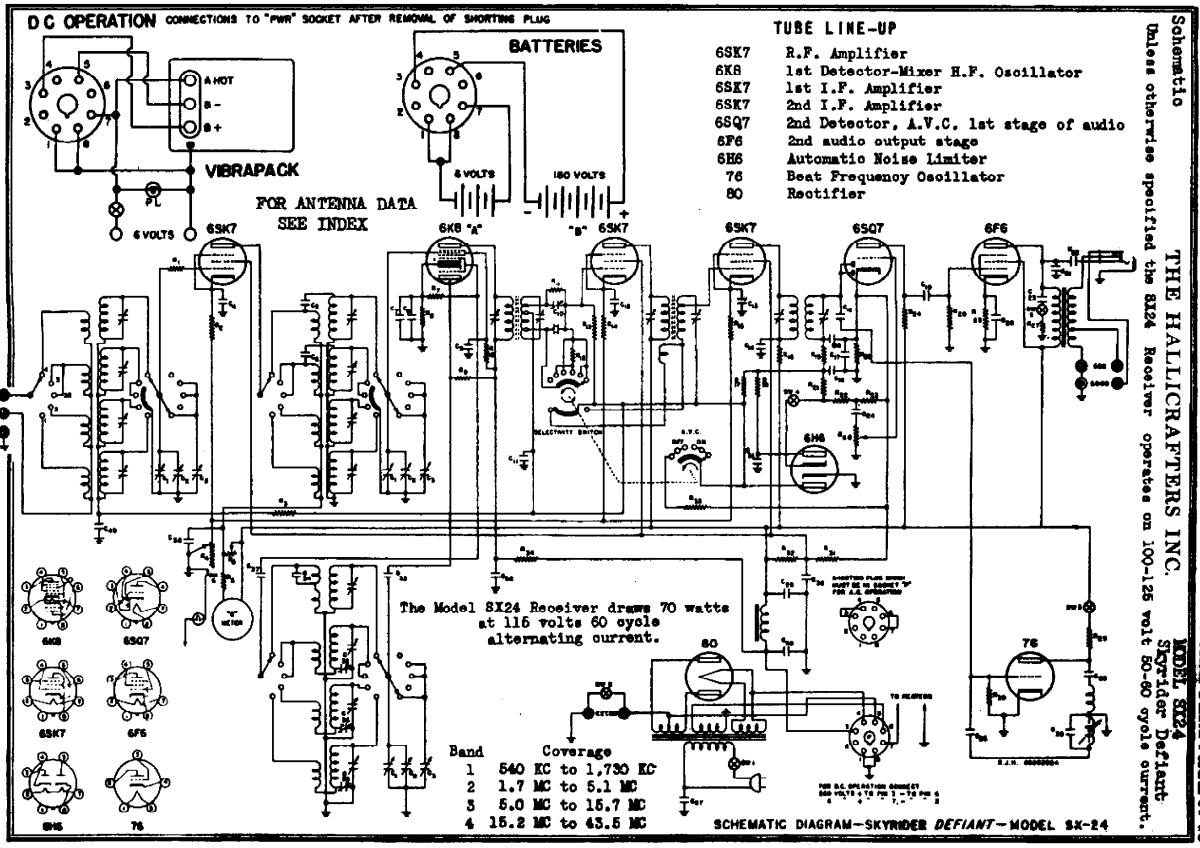

Schematic
 THE HALLICRAFTERS INC.
 MODEL SX24
 Sky Rider Defiant
 Unless otherwise specified the SX24 Receiver operates on 100-125 volt 50-60 cycle current.