



the hallicrafters co.

MANUFACTURERS OF ELECTRONIC EQUIPMENT, CHICAGO 24, U. S. A.

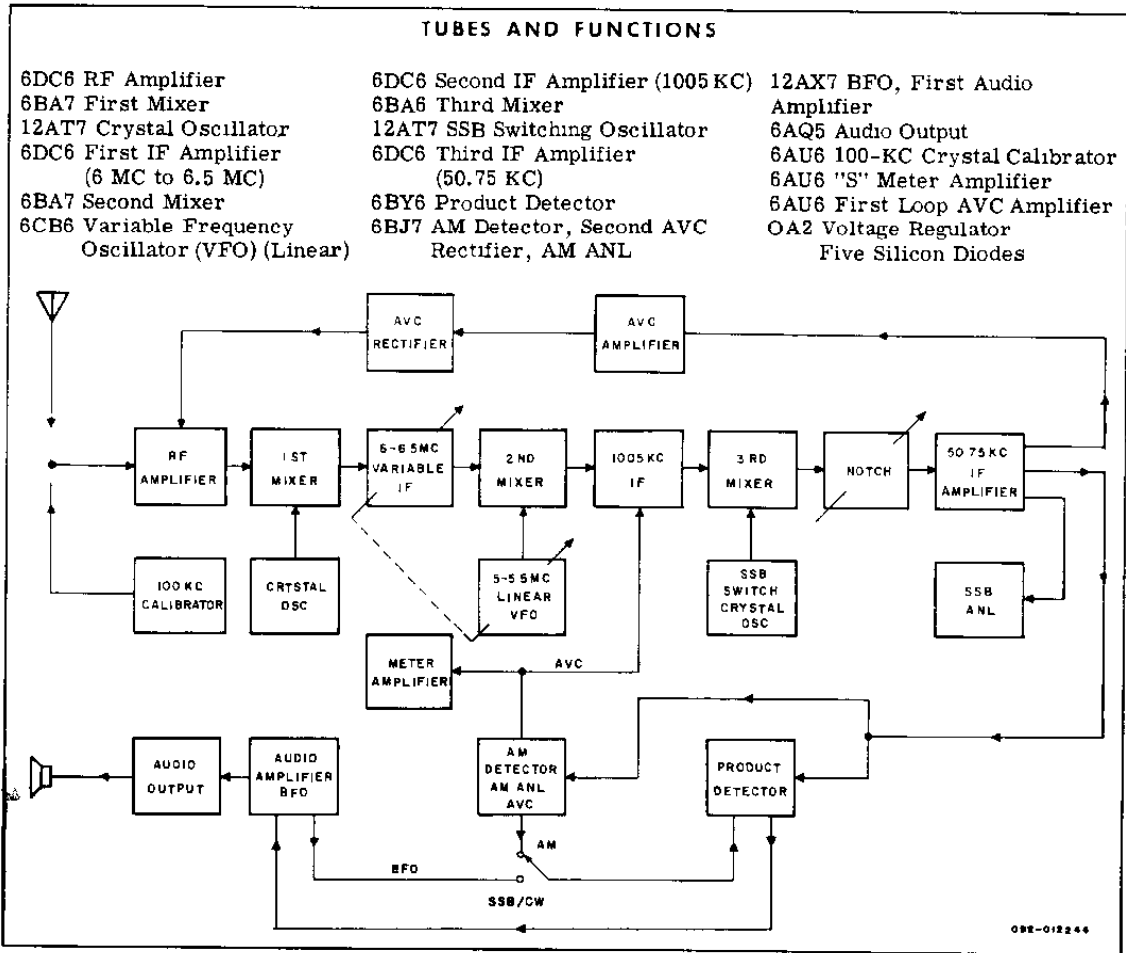

Figure 1. Block Diagram of Receiver.

TECHNICAL SPECIFICATIONS

FREQUENCY COVERAGE	
20-Meter Band	14.0 MC to 14.5 MC.
15-Meter Band	21.0 MC to 21.5 MC.
10-Meter Band	28.0 MC to 28.5 MC.
10-Meter Band	28.5 MC to 29.0 MC.
10-Meter Band	29.0 MC to 29.5 MC.
10-Meter Band	29.5 MC to 30.0 MC.

TECHNICAL SPECIFICATIONS (CONT.)

IF FREQUENCIES	6.505 MC to 6.005 MC (Variable), 1005 KC, and 50.75 KC.
RECEPTION	AM, CW, and Single Sideband (SSB).
SENSITIVITY-AM	Less than 1 microvolt for a 10-DB signal-to-noise ratio (30% modulation).
SENSITIVITY-SSB/CW	Less than 1/2 microvolt.
SELECTIVITY	Variable in five steps providing 0.5, 1, 2, 3, and 5 KC bandwidth at 6 DB down.
STABILITY	Better than 300 cycles after a 15-minute warmup.
CALIBRATION ACCURACY	Better than 1000 cycles between 100-KC calibration points after indexing.
IF REJECTION	More than 1000X (60 DB) down.
IN-BAND TWEETS	Less than 1 microvolt equivalent.
POWER GAIN	Less than 1 microvolt (30% modulation) for 0.5 watt audio output.
AUDIO POWER OUTPUT	1.5 watts with distortion less than 10%.
AVC FIGURE OF MERIT	More than 60 DB.
POWER SOURCE	105 volts to 125 volts, 50/60 cycles.
POWER CONSUMPTION	85 watts.
NUMBER OF TUBES	18 (including voltage regulator), plus 5 silicon diodes.
SPEAKER OUTPUT	3.2 ohms and 500 ohms, rear-mounted,
HEADPHONE OUTPUT	50 ohms to 2000 ohms; panel mounted phone jack accepts standard 1/4-inch phone plug.
ANTENNA INPUT	50 ohms to 70 ohms unbalanced; rear chassis mounted SO-239 receptacle accepts Amphenol type 63-ISP coaxial connector.
AUXILIARY CONTROL SOCKET	Rear chassis mounted octal socket accepts standard 8-pin octal plug (supplied).
DIMENSIONS (overall)	16 inches wide, 10-1/2 inches high, and 16 inches deep.
SHIPPING WEIGHT	47 pounds.
NET WEIGHT	44 pounds.



Figure 2. View of Model SX-115 Receiver.

SECTION I

GENERAL DESCRIPTION

1-1. INTRODUCTION.

The Model SX-115 is a triple-conversion, heterodyne-type communications receiver having the following features:

A high order of mechanical and electrical stability.

Accurate frequency readout.

Linear tuning.

1-KC calibration marks on all bands.

Constant tuning rate.

Transmitter-type VFO with differential temperature compensation.

Back-lash free, gear-driven tuning mechanism.

Crystal-controlled first and third conversion oscillators.

Less than 1/2 microvolt sensitivity on SSB and CW.

Excellent spurious and image rejection.

Selectable sidebands.

Selectivity variable in five steps from 500 CPS to 5 KC.

Amplified, dual-loop AVC with fast attack and slow release.

Product detector for SSB/CW; envelope detector for AM.

IF-type noise limiter for SSB/CW; automatic threshold series type for AM.

Band gain equalization.

Audio inverse feedback.

Reduced weight through the use of aluminum panel and chassis construction.

Built-in, 100-KC crystal calibrator.

Heating element for reduced warmup drift.

SECTION II

INSTALLATION

2-1. UNPACKING.

After unpacking the receiver, examine it closely for damage which may have occurred in transit. Should any sign of damage be apparent, file a claim immediately with the carrier stating the extent of damage. Carefully check all shipping labels and tags for instructions before removing or destroying them.

2-2. LOCATION.

The receiver may be placed in any location that will permit free air circulation through the ventilation holes and openings in the cabinet.

2-4. GROUNDS.

All station equipment should be bonded together with heavy copper wire or braid and connected to a cold water pipe or earth ground. An external chassis ground terminal is provided on the rear of the Model SX-115 for this purpose.

2-5. POWER SOURCE.

The SX-115 is designed to operate from a 105-volt to 125-volt, 50/60-cycle AC power source. Power consumption is 65 watts.

NOTE

Use a light-colored wire for power source

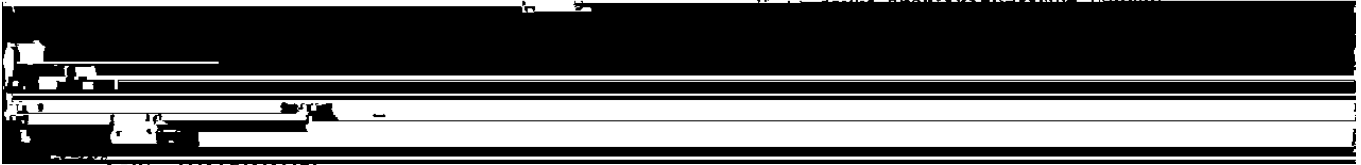

The Model SX-115 uses a special bandpass type circuit designed for an unbalanced 50-ohm to 70-ohm input. Any of the popular dipole or beam antennas using 50-ohm to 70-ohm coaxial transmission line will suffice. It should be remembered, however, that these antennas will only give optimum results over a limited frequency range. Generally speaking, the same rules that apply to transmitting antennas will hold true for receiving antennas. For further information on this subject, refer to the "Radio Amateur's Handbook" or the "A.R.R.L. Antenna Book", both published by the American Radio Relay League, West Hartford, Connecticut, U.S.A.

IMPORTANT

Some form of lightning protection should be provided which will comply with local code requirements.

2-6. SPEAKER.

A three-contact terminal strip, marked "G", "3.2" and "500", is provided at the rear of the receiver for connecting an external speaker or line (see figure 3). Any permanent-magnet type speaker with a 3.2-ohm voice coil can be used by connecting the two leads from the speaker voice coil to the terminals marked "3.2" and "G". If it is desired to use a speaker with a voice coil impedance other than 3.2 ohms, a matching transformer should be employed to insure optimum performance. The transformer should be mounted on or near the speaker and should have a five-watt power rating, a 500-ohm primary impedance, and a secondary impedance to match that of the speaker voice coil. Connect the primary of the matching transformer to terminals "500" and "G" and the secondary to the speaker voice coil terminals.

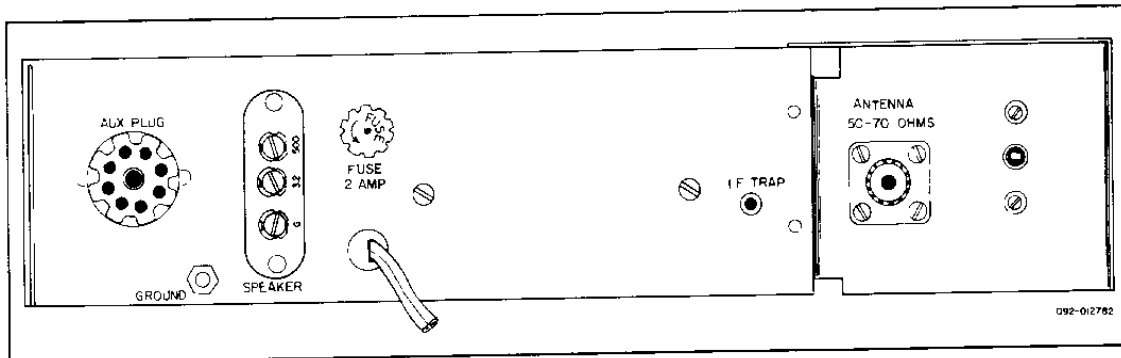

Figure 3. Rear View of Receiver.

SECTION III

FUNCTION OF OPERATING CONTROLS

3-1. RF GAIN CONTROL.

The RF GAIN control varies the gain of the RF amplifier and the 1005-KC IF amplifier. Maximum sensitivity is obtained with the control set at "10" (fully clockwise). In this position, the tubes being controlled are operating at maximum gain with minimum cathode bias. As the control is rotated counterclockwise, the cathode bias is in-

stages except the "S" meter amplifier. This allows the "S" meter to be used to indicate relative signal strength or as a tuning indicator. In the AVC ON position, both AVC loops are in operation to automatically control the receiver gain. In the SSB-ANL position, the AVC circuitry remains in operation and the SSB IF noise limiter is placed in operation. This position should be used on SSB if noise problems are encountered. It may be found desirable to use this

To realize the full benefit of the excellent AVC characteristics of the Model SX-115 and to obtain accurate "S" meter readings, the RF GAIN control should be set at "10" (maximum sensitivity) for all conditions of normal operation.

3-2. BAND SELECTOR CONTROL.

The BAND SELECTOR control operates the bandswitch to place the proper crystal and coils into the circuit to cover the desired frequency range. The band covered by each position is indicated in the window directly above the control. This control also actuates the dial pointer so that the dial scale in use may be readily identified. Band gain equalization is automatically provided by this control.

3-3. ANTENNA TRIMMER.

The ANT. TRIM control operates a variable capacitor connected across the secondary of the antenna coil in use. Adjustment of this capacitor compensates for the loading effect of various types of antennas. This control is adjusted for maximum signal after the TUNING control is adjusted to the desired frequency. Once adjusted, the ANT. TRIM usually requires no further adjustment until the receiver is switched to another band.

3-4. AUDIO GAIN CONTROL.

The AUDIO GAIN control adjusts the audio output level at the speaker terminals and PHONES jack. Clockwise rotation increases the signal

CW signals. This position is not satisfactory for AM reception.

The AM-ANL position allows the AVC circuitry to remain in operation and also places the automatic threshold series noise limiter in operation. This position should be used, as noise conditions dictate, for AM reception. This position is not satisfactory for SSB or CW reception.

3-6. SELECTIVITY CONTROL.

The SELECTIVITY control is used to vary the IF selectivity of the receiver to suit receiving conditions. Five degrees of selectivity are available, ranging from 500 CPS for CW reception under crowded band conditions to 5 kilocycles for maximum fidelity of voice modulated signals where band conditions permit. The five selectivity positions are indicated on the SELECTIVITY control and indicate the 50.75-KC IF bandwidth at the 6-DB points.

NOTE

Unlike most receivers, the selectivity is improved in the AVC-ON position because of the selectivity characteristics of the front-end AVC loop. Figure 6 contains IF selectivity curves.

Recommended positions for various modes

are:

CW	0.5 KC or 1 KC
SSB	2 KC or 3 KC
AM	3 KC or 5 KC

3-7. I-NOTCH FILTER.

vides AVC OFF, AVC ON, SSB noise limiting and AM noise limiting. In the AVC OFF position, AVC voltage is removed from all controlled

frequency devices and eliminates one heterodyne if the heterodynes are separated by more than 500 cycles in frequency.

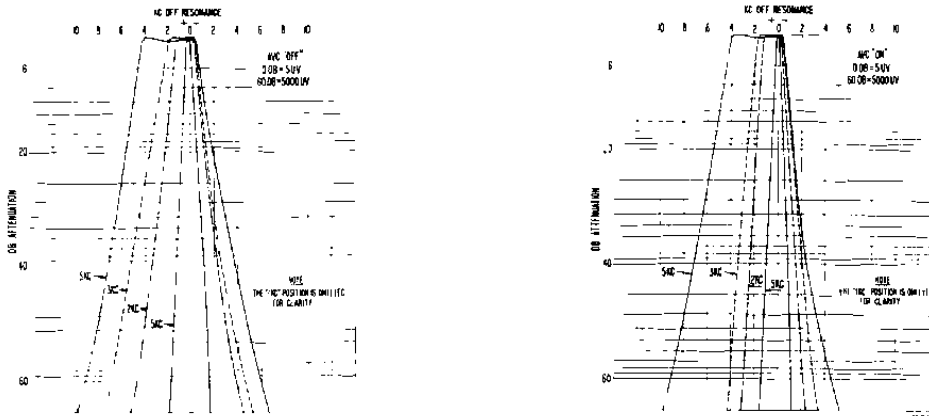

Figure 6. IF Selectivity Curves.

The T-Notch is very effective when using exalted carrier reception (AM with BFO on). The NOTCH control is adjusted to approximately 50

it switches the third conversion oscillator to operate at the required frequency (995 KC for LOWER sideband and 1055 KC for UPPER side-

is not tuned to exactly zero beat with the incoming signal. The AM signal under these conditions will

selects either the product detector circuit (SSB/CW) or the diode detector (AM), connecting the

ment to allow the beat frequency oscillator to be set at exactly 50 KC.

NOTE

The PITCH control should not be used for tuning purposes as the BFO frequency must be maintained if best performance is to be achieved.

The correct control setting will be near "0" on the PITCH control knob. The exact point may be found by placing the FUNCTION control in UPPER SSB/CW, the SELECTIVITY to 5 KC, and the XTAL CAL. switch to ON.

Adjust TUNING to near zero beat at any 100-KC Cal. check point. Switch the FUNCTION control to LOWER SSB/CW and adjust the PITCH control until the frequency of the beat note remains the same in either UPPER or LOWER SSB/CW position. After this position has been established, the control should remain in this position at all times.

3-9. FUNCTION SWITCH.

The FUNCTION switch performs four functions: (1) It turns the receiver ON and OFF; (2)

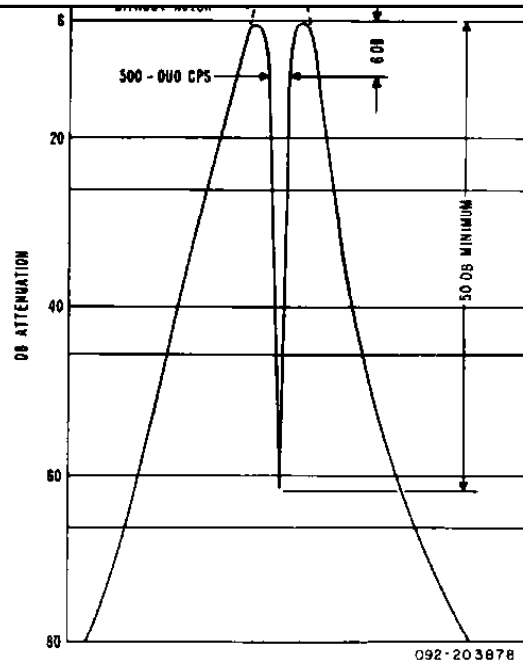

Figure 7. IF Selectivity with Notch.

To illustrate how selectable sideband reception is accomplished, a numerical example is given. Consider an incoming signal at 7000 KC, modulated 1 KC. Since modulation of a carrier causes the generation of sideband frequencies numerically equal to the carrier frequency plus or minus the modulation frequency, the incoming signal consists of the carrier at 7000 KC, a lower sideband at 6999 KC, and an upper sideband at 7001 KC. See figure 8.

The incoming signal is first heterodyned with the output of the first conversion oscillator in the first mixer. The first conversion oscillator operates at a frequency higher than the incoming signal by an amount equal to the first IF frequency of 6,505 MC (variable IF). As a result of this, three new lower frequencies are produced in the output of the first mixer: the carrier at 6,505 MC, the lower sideband at 6,506 MC and the upper sideband at 6,504 MC. These signals are amplified by the 6,505 MC to 6,005 MC IF stage and then heterodyned with the output of the VFO (5.5 MC to 5.0 MC) in the second mixer. Three new lower frequencies are again produced in the output of this mixer stage: a center frequency of 1005 KC, a lower sideband of 1006 KC and an upper sideband of 1004 KC. These signals are amplified by the 1005-KC IF amplifier and fed to the third mixer where they are heterodyned with the output of either the 955-KC (lower sideband) or the 1055-KC (upper sideband) crystal controlled third conversion oscillator. When the FUNCTION switch is placed in LOWER position, three new lower frequencies are produced: the carrier frequency at 50 KC, the lower sideband at 51 KC and the upper sideband at 49 KC. By referring to figure 6, it can be seen that the lower sideband falls within the

IF passband and the upper sideband is rejected. When the FUNCTION switch is placed in UPPER position, the carrier frequency remains at 50 KC but the sidebands have been reversed in the heterodyning process. The upper sideband will now be 51 KC and falls within the IF passband while the lower sideband will appear at 49 KC and be rejected.

3-10. XTAL CAL. SWITCH.

The XTAL CAL. switch controls the operation of the built-in, 100-KC crystal calibrator. When the switch is placed at ON, the calibrator will provide marker signals at every 100-KC point on the dial.

NOTE

The XTAL CAL. switch should be turned to OFF immediately after dial calibration has been completed to avoid the possibility of generating spurious responses in the receiver.

3-11. TUNING CONTROL.

The TUNING control is used to tune the desired signal within the selected band. It also operates the main tuning dial and the kilocycle dial.

The receiver frequency is read from the dial as follows:

The red pointer rising from the hub of the main tuning dial follows the bandswitch setting to show the scale in use. This dial scale carries the 100-KC increments and, for reference, the 50-KC markers.

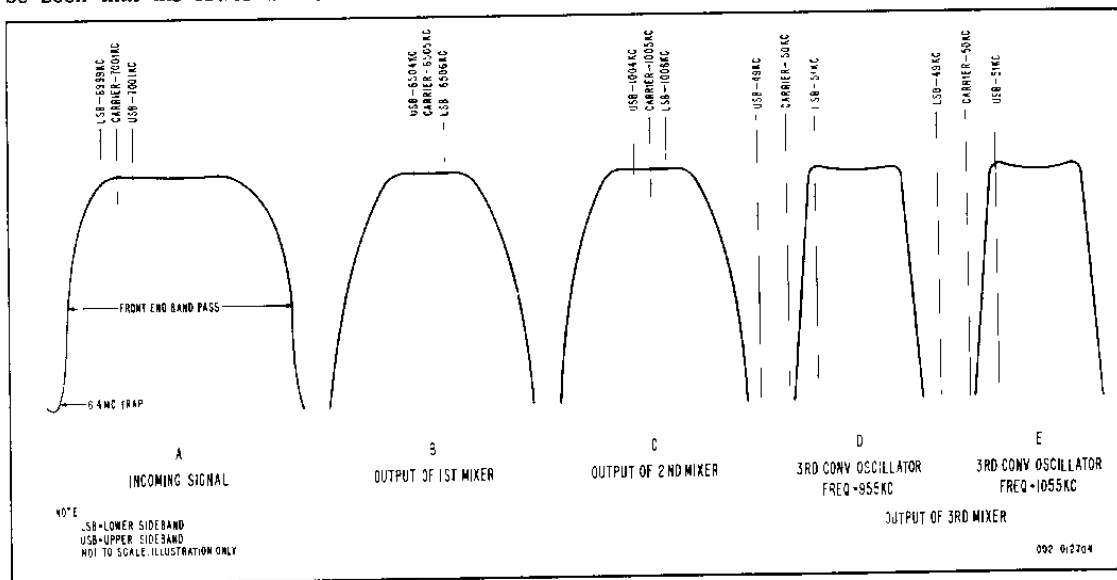

Figure 8. Selectable Sideband Response Curves.

Located at the outer rim of the dial is a fixed pointer and the 25-KC increment scale which divides the 100-KC segments into 25-KC segments. Note that each rotation of the TUNING knob changes the receiver frequency by 25 KC, dividing the 25-KC segments into 1-KC segments.

The dial frequency may be read in the following manner; Read the pertinent numbers on the main dial scale in use. These appear to the left of the movable pointer. To this, add the number of kilocycles that are indicated to the left of the pointer on the segment scale at the

To obtain maximum calibration accuracy, the VFO unit should be indexed at the nearest 100-KC calibration mark on the dial. This may be accomplished in the following manner:

1. Turn the XTAL CAL. switch to ON.
2. Turn the FUNCTION switch to UPPER or LOWER SSB/CW.
3. Adjust the TUNING control to zero beat at the nearest 100-KC point.

3985 KC is arrived at as follows:

3900 KC on the 60 M scale plus 75 KC on the outer scale plus 10 KC on the kilocycle dial = 3985 KC.

3-12. CAL SET CONTROL.

The CAL. SET control serves two functions: first, it indexes the kilocycle dial exactly to frequency; second, it serves as a friction brake on the tuning mechanism to prevent accidental frequency shift.

(fully clockwise). Tune back to zero beat with the kilocycle dial locked. This allows the receiver tuning to be changed but holds the kilocycle dial stationary at the desired point. After zero beat has been reached, release CAL. SET (turn fully counterclockwise).

For accurate frequency readout on AM, the FUNCTION switch should be placed in UPPER or LOWER SSB/CW position and the TUNING adjusted to zero beat with the incoming carrier. If exalted carrier reception (AM with BFO on) is used, the indicated frequency will be the correct frequency.

SECTION IV OPERATION

4-1. SINGLE-SIDEBAND RECEPTION.

Set the front panel controls as outlined below.

RF GAIN 10 (maximum sensitivity)

BANDSELECTOR. To desired band

AUDIO GAIN Approximately 2

AVC-ANL AVC ON

SELECTIVITY 2 KC or 3 KC

FUNCTION Usually LOWER SSB/
CW for 80 and 40
meters and UPPER
SSB/CW for 20, 15,
and 10 meters.

PITCH 0

NOTCH OFF

RECEIVE- RECEIVE
STANDBY

CAL. SET OFF

XTAL CAL. OFF

ANT. TRIM 0

TUNING As desired

Slowly adjust the TUNING control until voice modulation sounds natural. Peak the ANT. TRIM for maximum "S" meter indication. Adjust the AUDIO GAIN control as desired. Adjust the SELECTIVITY control for best reception. If an undesirable heterodyne appears, adjust the NOTCH control for maximum attenuation.

It should be remembered that an SSB signal will convey intelligence only when the correct sideband position has been selected on the FUNCTION switch. If the signal does not tune in properly, change the FUNCTION switch to the other SSB/CW position.

The RF GAIN control should be set at 10 (maximum sensitivity) for all conditions of normal operation and the receiver volume should be controlled with the AUDIO GAIN control. Failure to do this will degrade the excellent AVC characteristics of the receiver and will also change the "S" meter calibration.

Do not use the PITCH control for tuning purposes. It must be set as described in paragraph 3-8 if best performance is to be realized.

The AVC-ANL control may be used as conditions warrant for noise reduction.

4-2. CW RECEPTION.

Set all controls as described under single-sideband reception except for the SELECTIVITY and AVC-ANL controls.

The SELECTIVITY control will normally be in the 0.5-KC or 1-KC position for CW reception.

The AVC-ANL control should be placed in SSB-ANL position at all times. This is very useful in removing key clicks as well as impulse type noise.

Under all conditions of normal operation, the RF GAIN control should be set at 10 (maximum gain). Do not use the PITCH control for tuning purposes.

4-3. AM RECEPTION.

Set all controls as described under single-sideband reception except for the FUNCTION and SELECTIVITY controls.

The FUNCTION control should be placed in UPPER or LOWER AM and the SELECTIVITY control should be in the 3-KC or 5-KC position.

The NOTCH control may be used as necessary for removing undesirable heterodynes.

The AVC-ANL switch may be placed in AM-ANL position as conditions warrant for noise reduction.

4-4. EXALTED CARRIER AM RECEPTION.

In short-wave reception, it frequently happens that transmission conditions are different for waves of slightly different frequencies. As a result, in the case of voice modulated transmissions, AM particularly, which involve sideband frequencies differing slightly from the carrier frequency, the carrier and sideband components may not be received in the same relative amplitudes and phases that were present at the trans-

mitter. This effect, known as selective fading, causes severe distortion of the signal.

This type of distortion can be reduced considerably by utilizing the selectable sideband feature of the Model SX-115 receiver operating in an exalted carrier mode (i.e., the transmitted carrier is positioned out of the receiver's IF passband along with one sideband, producing a suppressed carrier single-sideband signal). The carrier is subsequently reinserted by the receiver's BFO and the signal is detected in the same manner as a single-sideband signal.

All controls should be set as described under single-sideband reception. Place the FUNCTION switch in the SSB position that gives best reception. In addition, the NOTCH control should be adjusted to the carrier frequency (approximately 50 KC) to null out the incoming signal carrier.

If noise conditions warrant, the AVC-ANL control should be used.

4-5. USE AND ADJUSTMENT OF "S" METER.

The "S" meter provides a visual means of determining whether or not the receiver is properly tuned, as well as an indication of the signal strength. The "S" meter circuit consists of a D.C. milliammeter connected in the cathode circuit of the meter tube, the grid of which is controlled by AVC voltage. Since the cathode current of the tube varies with the strength of the incoming signal, the meter will indicate signal strength. The meter is calibrated in "S" units from 1 to 9, and in decibels to 60 DB above S9. The indications on the "S" meter will be correct only when the RF GAIN control is set at "10" (maximum sensitivity) and the AVC switch is set at ON.

NOTE

The "S" meter will also indicate relative signal strength with the AVC OFF and/or with the RF GAIN control not at maximum sensitivity.

S9 represents a 50-microvolt signal at the antenna input to the receiver, assuming a 50-ohm termination. Each "S" unit represents approximately 6-DB change in signal strength.

For accurate readings, both the mechanical and electrical zero adjustments on the meter should be checked periodically.

The mechanical zero adjustment is at the rear of the meter and is adjusted (with receiver power off) so that the pointer is exactly at the end of the meter scale on the right-hand side.

The electrical zero adjustment (meter zero) should be made after the receiver has been thoroughly warmed up. With the RF GAIN control at "O", the meter zero control (mounted on top of chassis near the VFO) is adjusted so that the meter pointer is exactly at the end of the meter scale on the left-hand side.

NOTE

Do not adjust factory gain control unless an accurately calibrated signal source is available (see Adjustment of Factory Gain "S" Meter Control).

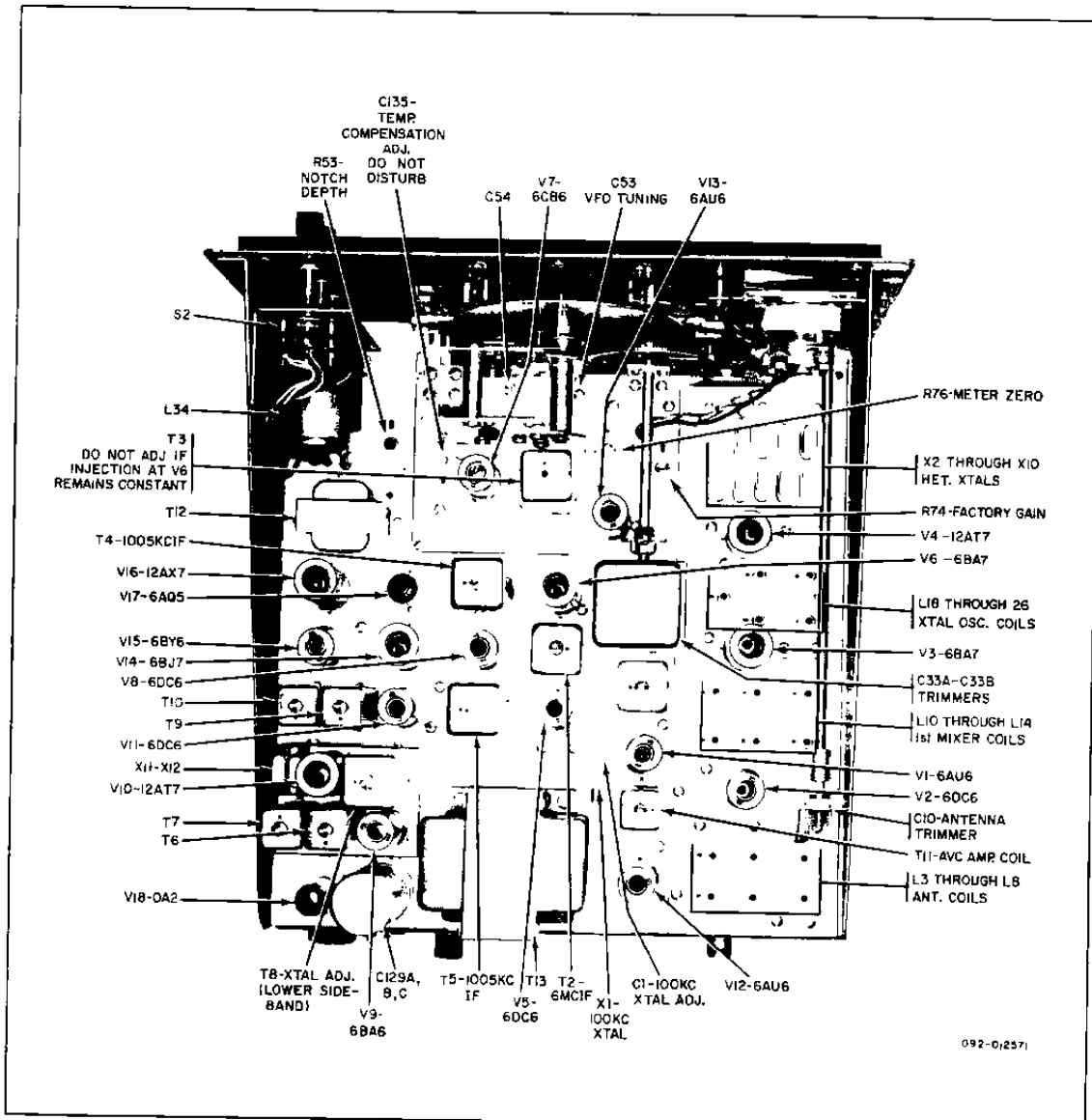

Figure 9. Top Chassis View of Receiver.

SECTION V

ALIGNMENT

5-1. GENERAL.

Alignment of the receiver should not be attempted until all other possible causes of faulty operation have been exhausted.

NOTE

Do not make any alignment adjustments unless the operation of this receiver is fully understood and adequate test equipment is available.

5-2. TEST EQUIPMENT REQUIRED.

1. Signal generator having 50-KC to 30-MC coverage, a calibrated output level meter, and a 50-ohm termination.

2. Vacuum tube voltmeter (VTVM).

3. Output meter (or AC scale of VTVM). If a VTVM is used, connect it to terminals "500" and "G", and terminate the output with a 500-ohm, 2-watt, resistive dummy load.

4. Alignment tool such as General Cement's No. 8606.

5-3. INITIAL CONTROL SETTINGS.

BANDSELECTOR . . . As indicated in chart

AUDIO and RF GAIN . . . 10 (Maximum)

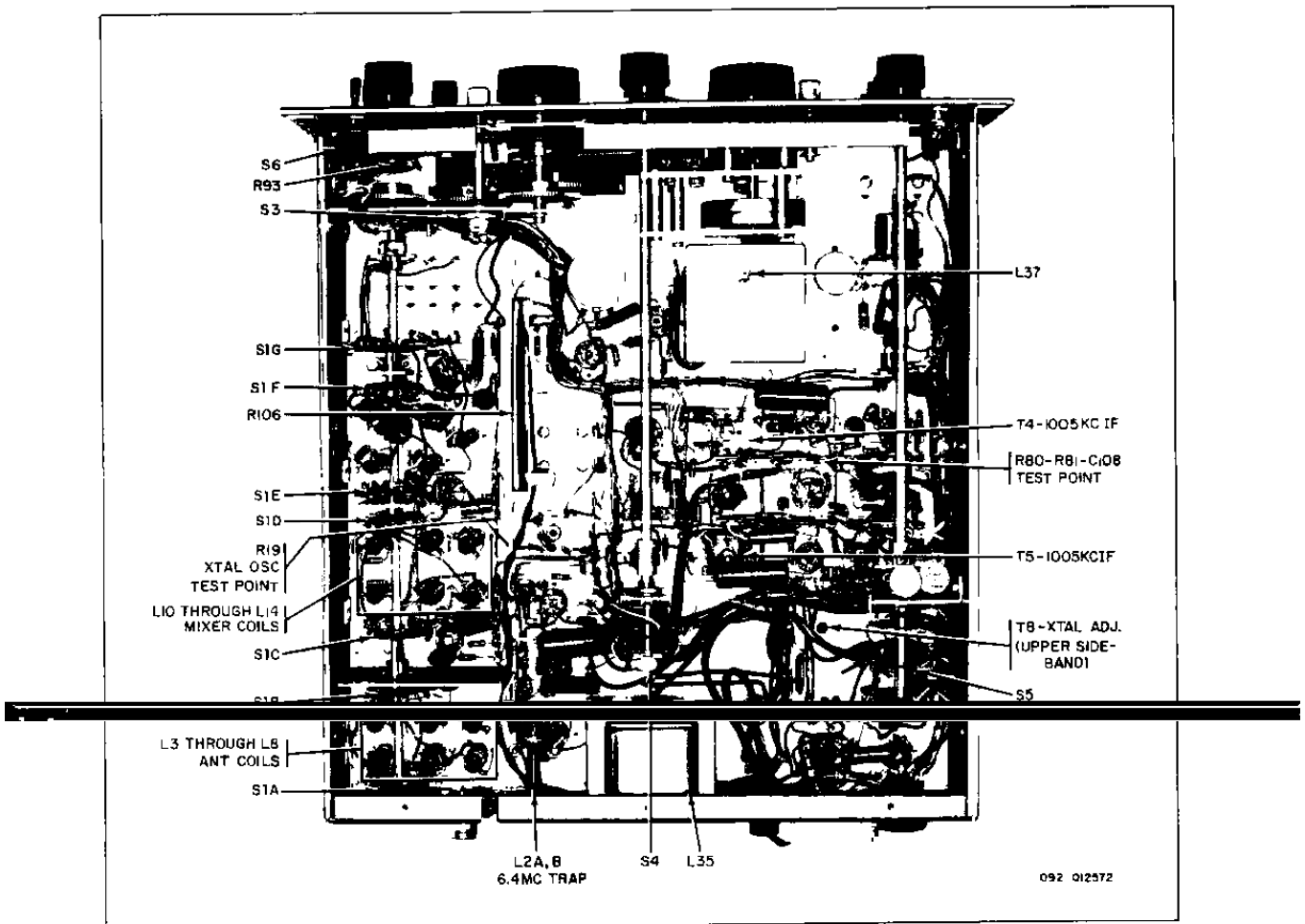

Figure 10. Bottom Chassis View of Receiver.

AVC OFF

TUNING As indicated in chart

SELECTIVITY As indicated in chart

NOTCH OFF

FUNCTION UPPER - AM

ANT. TRIM Mid-point

RECEIVE - RECEIVE
STANDBY

XTAL CAL. OFF

PITCH 0

5-4. ALIGNMENT PROCEDURE.

Step	Signal Generator Connections	Generator Frequency	Band	Output Connections	Selectivity Setting
1	High side directly to terminal 1 of T5	50.75 KC unmod (critical)	60M	VTVM DC Probe to junction of R80, R81, and C108	.5 KC
Remove first conversion oscillator tube (V4) from socket to prevent signal interference. Adjust			top slugs of T6, T7, T9, T10 for maximum indication maintaining approximately 1-volt reading on VTVM.		

Alignment of 1055-KC Third Conversion Oscillator and 1005-KC IF's

Step	Signal Generator Connections	Generator Frequency	Band	Output Connections	Selectivity Setting
2	High side directly to pin 7 of V6	1005 KC mod	80M	Output meter across appropriate speaker output terminals	5 KC
Tune generator slowly through 1005 KC to determine IF passband. Then set generator to center of passband, using sufficient generator output to obtain approximately 1/2 watt receiver output. If no output is obtained, the 1055-KC crystal oscillator may not be oscillating and it will be necessary to turn up the generator output and adjust the 1055-KC crystal activity adjustment (bottom slug of T8) until output is obtained. Adjust for maximum output by adjusting the generator frequency, crystal activity, and the 1005-KC IF slugs (top and bottom of T4 and T5). Note that the signal suddenly disappears when the crystal activ-			ity slug is turned into the coil and gradually drops in level when the slug is backed out of the coil. Set the crystal activity adjustment (bottom slug of T6) for a 8-DB reduction in level (as indicated on the output meter) on the gentle slope side of maximum response. Then set the generator as near the center of the IF passband as possible, tune in either direction from center, and observe the response. If it is symmetrical, the adjustment is completed; if not, reset the generator frequency near the center of the passband and repeak T4 and T5.		

Alignment of 955-KC Third Conversion Oscillator

Step	Signal Generator Connections	Generator Frequency	Band	Output Connections	Selectivity Setting
3	High side directly to pin 7 of V6	1005 KC mod	80M	Output meter across appropriate speaker output terminals	5 KC
Set FUNCTION control at LOWER-AM. Tune generator slowly through 1005 KC to determine IF passband. Set generator to center of passband, using sufficient generator output to obtain approximately 1/2 watt receiver output. If no output is obtained, the 955-KC crystal oscillator may not be oscillating and it will be necessary to turn up the generator output and adjust the 955-KC crystal activity adjustment (bottom slug of T8) until output is obtained. Adjust for maximum output by ad-			justing the signal generator frequency and the crystal activity (top slug of T8). Note that the signal suddenly disappears when the crystal activity slug is turned into the coil and gradually drops in level when the slug is backed out of the coil. Set the crystal activity adjustment (bottom slug of T6) for a 8-DB reduction in level (as indicated on the output meter) on the gentle slope side of maximum response. Then set the generator as near the center of the IF passband as possible, tune in either direction from center, and observe the response. If it is symmetrical, the adjustment is completed; if not, reset the generator frequency near the center of the passband and repeak T4 and T5.		

Alignment of 8.0-MC to 6.5-MC Variable IF

4	High side directly to pin 7 of V3	8.050 MC	80M	Output meter across appropriate speaker output terminals	5 KC
5	Same	6.45 MC	Same	Same	Same

Replace V4 and adjust receiver TUNING until a signal is heard at approximately 3.95 MC. Adjust top slug of T1 and T2 for maximum receiver output.

Adjust receiver TUNING until a signal is heard

at approximately 3.55 MC. Adjust both trimmers on C33 for maximum receiver output. These trimmers are accessible through the side of the shield can that covers C33. Repeat slug and trimmer adjustments as previously described until no further increase is noted.

5-5. ADJUSTMENT OF CRYSTAL CONTROLLED FIRST CONVERSION OSCILLATOR.

All of the coil forms in this group, except the WWV coil, have two separate coils and two separate adjustments; (i.e., 80M and 10M-1, 40M and 10M-2, etc.). In all cases, the low frequency adjustment will be nearest the top of the chassis and the 10-meter adjustment will be the core near the bottom of the coil form (see figure 11). All adjustments may be made from the top or bottom of chassis when using an alignment tool such as General Cement's No. 8606.

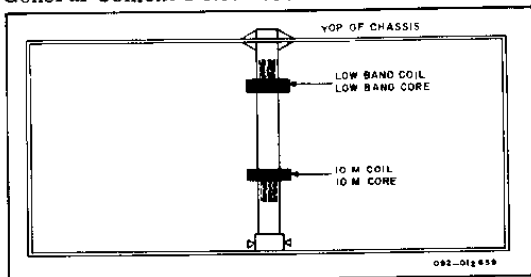

Figure 11. Coil Forms (Crystal Oscillator Plate).

Connect a VTVM (set to read negative DC voltage on 10-volt scale) at the point where R19 (1 megohm) connects to terminal strip near V3. Starting with 80M, adjust each oscillator core in order of increasing frequency, for maximum voltage indication on the VTVM as the BAND SELECTOR switch is advanced through the various ranges. Coil locations are clearly marked on the chassis.

NOTE

After all other adjustments have been made, it is permissible to warp the crystal frequency by rotating the appropriate core slightly to allow more accurate band-to-band calibration, consistent with positive oscillator start as the BAND SELECTOR is rotated through each range.

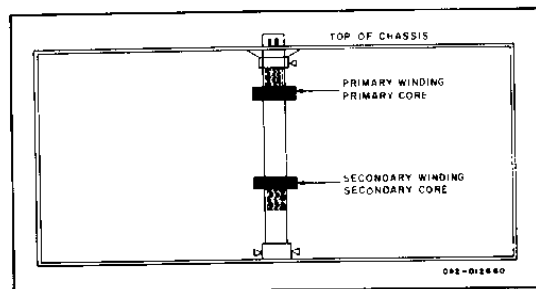

Figure 12. Coil Forms (Antenna and Mixer).

NOTE

Cores may be adjusted from top or bottom of chassis when using an alignment tool such as General Cement's No. 8606.

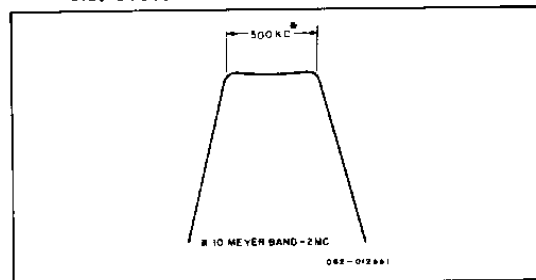

Figure 13. Typical Front-end Response Curve (Except 10-meter Band).

5-6. ALIGNMENT OF BANDPASS ANTENNA AND FIRST MIXER COILS.

No attempt should be made to adjust these coils unless component parts in this circuitry have been replaced, or if the gain appears abnormally low over a portion of a particular band.

Controls should be set as follows:

RF GAIN 10 (maximum sensitivity)
AUDIO GAIN 10 (maximum output)
AVC OFF
FUNCTION UPPER-AM
NOTCH OFF
CAL. SET OFF
ANT. TRIM Mid-range (half capacity)
SELECTIVITY 2 KC

The following will apply to all bands except 10 meters. Coil locations are marked on chassis.

- a. Connect signal generator to antenna input on receiver using 50-ohm termination.
- b. Connect output meter across appropriate speaker terminals.
- c. Starting with 80 meters, adjust each band in order of increasing frequency. If it is determined that only one band needs alignment, adjustments should be made only for that band.
- d. Set receiver TUNING 25 KC in from the high frequency end of the dial (i.e., 3.975 MC, 7.475 MC, etc.) and adjust signal generator to the same frequency. (Keep generator level as low as possible to avoid receiver overload.)
- e. Peak appropriate mixer primary and secondary cores and also antenna primary and secondary cores for maximum receiver output. Repeat to cancel out any interaction between adjustments.
- f. Set receiver TUNING to center of dial (i.e., 3.750 MC, 7.250 MC, etc.) and adjust signal generator to the same frequency.
- g. With ANT. TRIM set at mid-range, peak the antenna secondary core only (see coil sketch) for maximum receiver output.
- h. Retune receiver and signal generator to point 25 KC in from high frequency end of dial. Carefully tune in signal and adjust the ANT. TRIM for maximum receiver output. Observe signal generator level and receiver output level.

- i. Tune receiver and signal generator to a point 25 KC in from low frequency end of dial (i.e. 3.525 MC, 7.025 MC, etc.). Keep signal generator level constant, peak ANT. TRIM and observe receiver output level.
- j. If receiver output does not equal that obtained at the high frequency end of the dial, turn mixer primary (top) core in very small increments (usually clockwise from top of chassis) until equal output is obtained at both check points.

NOTE

ANT. TRIM should be peaked for maximum receiver output at each check point.

5-7. ALIGNMENT OF 10-METER BANDPASS ANTENNA AND MIXER COILS.

Equipment needed and connections will be the same as described above.

- a. Set BAND SELECTOR to 10M-4 (29.5 MC to 30 MC).
- b. Adjust receiver TUNING and signal generator to 29.975 MC.
- c. With ANT. TRIM at mid-range, peak 10M mixer primary and secondary cores, and 10M antenna primary and secondary cores for maximum receiver output. Repeat to cancel out any interaction between adjustments.
- d. Set BAND SELECTOR to 10M-2 (26.5 MC to 29 MC) and adjust receiver TUNING and signal generator to 29 MC.
- e. With ANT. TRIM at mid-range, peak 10M antenna secondary only (see coil sketch) for maximum receiver output.
- f. Set BAND SELECTOR back to 10M-4 (29.5 MC to 30 MC) and adjust receiver TUNING and signal generator to 29.975 MC. Carefully tune in signal, peak ANT. TRIM, observe signal generator level and receiver output level.
- g. Set BAND SELECTOR to 10M-1 (28 MC to 28.5 MC) and adjust receiver TUNING and signal generator to 28.025 MC. Carefully tune in signal and peak ANT. TRIM for maximum receiver output.

- h. If receiver output does not equal that obtained at 29.975 MC, turn mixer primary core (top) in very small increments until equal output is obtained at both check points (28.025 MC and 29.975 MC).

NOTE

ANT. TRIM should be peaked for maximum receiver output at each check point.

AVC ON
 FUNCTION UPPER-AM
 SELECTIVITY 3 KC
 TUNING 14.3 MC
 BAND SELECTOR 20M
 NOTCH OFF
 XTAL CAL. OFF

5-8. ADJUSTMENT OF IF TRAP.

Controls should be set as follows:

RF GAIN 10
 AUDIO GAIN 10
 AVC OFF
 FUNCTION UPPER-AM
 NOTCH OFF
 XTAL CAL. OFF
 ANT. TRIM Mid-range
 SELECTIVITY 2 KC
 BAND SELECTOR 40M

- a. Connect signal generator to antenna input.
- b. Set receiver TUNING at 7.1 MC.
- c. Set signal generator output level at approximately 1000 microvolts and tune to 6.4 MC.
- d. Adjust both cores in L2 (IF trap), located on rear apron of chassis, for minimum receiver output. Repeat adjustments until no further decrease in output is obtained.
- e. Check for uniform gain at 7.025 MC and 7.475 MC. If gain is not uniform, repeat adjustments as described in paragraph 5-6 on 40-meter band only.

5-9. ADJUSTMENT OF FACTORY GAIN METER CONTROL.

Controls should be set as follows:

AUDIO GAIN 0
 RF GAIN 10

- a. Connect signal generator to the antenna input. Set generator output level to 50 microvolts unmodulated and tune to 14.3 MC.
- b. Carefully adjust TUNING for maximum "S" meter deflection and peak ANT. TRIM.
- c. If "S" meter does not read S9, adjust factory gain control for correct reading.
- d. Turn RF GAIN control to "O" and check for electrical zero at left end of meter scale.
- e. Adjust meter zero as necessary and repeat the above steps until the meter reads S9 with the RF GAIN control at 10 and 0 with the RF GAIN control at 0. Both adjustments are located on top of chassis near the VFO.

5-10. BFO FREQUENCY ADJUSTMENT.

The beat frequency oscillator (BFO) has been adjusted at the factory so that its frequency is exactly 50 KC when the PITCH knob is set at "O". A slight readjustment may be necessary occasionally because of normal component aging. To determine if adjustment is required, proceed as follows:

With the SELECTIVITY control at 5 KC, FUNCTION at UPPER SSB/CW, XTAL CAL. at ON, and PITCH control at "O", adjust TUNING to zero beat at any 100-KC check point. Leaving the receiver TUNING unchanged, switch the FUNCTION switch to LOWER SSB/CW. If the beat oscillator frequency is correct, zero beat will be maintained in both the UPPER and LOWER SSB/CW positions. If the beat oscillator is off frequency, a beat note will be heard when switching from UPPER to LOWER SSB/CW. Adjustment of the oscillator is recommended only if the frequency of the audible beat note exceeds 200 CPS with the PITCH knob at "O".

NOTE

In instances where the beat oscillator is considerably off frequency, it may not be possible to obtain a zero beat when tuning through a signal. If this is the case, it will be necessary to roughly set the BFO to 50 KC as follows: Set SELECTIVITY to .5 KC, FUNCTION to UPPER SSB/CW, and tune receiver to a noisy part of band (not to a signal). Remove the PITCH knob and adjust the BFO slug for minimum noise. Set the SELECTIVITY control to 5 KC and make the BFO frequency check as outlined above.

If the BFO frequency check indicates adjustment is necessary, proceed as follows:

- a. Remove the PITCH control knob, turn the BFO slug a few degrees in the direction that lowers the beat note frequency, and repeat the BFO frequency check.
- b. Continue varying the setting of the slug in small steps and repeat the BFO frequency check until zero beat is obtained in both UPPER and LOWER SSB/CW positions.
- c. After the correct slug setting has been determined, replace the PITCH knob with "O" in the top center position, being careful not to disturb the slug setting.

5-11. NOTCH FREQUENCY AND DEPTH ADJUSTMENTS.

Readjustment of the notch filter circuit is not normally necessary unless the components in the notch circuit are replaced. To check the circuit, proceed as follows:

- a. Check the BFO frequency as previously described so that zero beat is maintained in either sideband position.
- b. Set FUNCTION to UPPER SSB/CW, SELECTIVITY to 3 KC and AVC to ON, and tune in an unmodulated signal

- f. Repeat steps "d" and "e" until no further decrease in meter reading is noted. At this point, the notch frequency should indicate 50 KC.

If the notch frequency does not indicate 50 KC with the receiver at zero beat as described above, loosen knob and reset it to 50 KC.

5-12. CRYSTAL CALIBRATOR ADJUSTMENT.

The crystal adjust trimmer is located near the power transformer on top of chassis and is used to adjust the 100-KC crystal exactly to frequency by comparison with the 10-MC signal transmitted by WWV.

- a. Set all receiver controls for AM reception, set BAND SELECTOR to WWV, and adjust TUNING to WWV signal (WWV mark on dial).
- b. During the period of no signal modulation, turn XTAL CAL. ON and carefully set the crystal adjust so that the crystal calibrator zero beats with the signal received from WWV.

NOTE

If this adjustment is attempted during periods that WWV is modulated, an erroneous zero beat may be obtained with the modulating frequency instead of the desired carrier frequency.

5-13. VFO CALIBRATION ALIGNMENT.

If the electrical index check at the 100-KC check points on all bands shows that the large dial calibration marks consistently fall to one side of the top pointer, a trimmer adjustment is indicated.

Proceed as follows:

- a. Mechanically index dial by tuning exactly to the lowest frequency calibration mark on main dial (i.e., 3.5 MC, 7.0 MC, etc.). The small kilocycle dial should read "O" at this point. If it does not, turn until kilocycle dial does read "O" and rotate CAL. SET to LOCK.

- e. Adjust notch depth (on top of chassis, right side of VFO) for further decrease in "S" meter reading.

- c. Loosen locknut on C54 (top of VFO) and carefully adjust C54 in very small

increments until zero beat is heard. Care should be exercised to make sure that the correct 100-KC beat note is tuned in with the trimmer.

- d. Check across the dial at the 100-KC check points. If the frequency error is less than 1000 cycles, the calibration will be within acceptable limits. If the error at the high frequency end of the dial (i.e., 4.0 MC, 7.5 MC, etc.) is greater than 1000 cycles, the VFO may require a coil adjustment in addition to the trimmer adjustment.

5-14. CONDITION REQUIRING COIL AND TRIMMER ADJUSTMENT

If the dial error progressively increases in the same direction with the high frequency end point running more than 1000 cycles in error, then adjust both L27 and C105 as follows:

- a. Mechanically index the VFO as previously described.
- b. Adjust TUNING exactly to high frequency end of dial (i.e., 4.0 MC, 7.5 MC, etc.) and adjust L27 to zero beat.
- c. Adjust TUNING exactly to low frequency end of band and adjust C54 for zero beat.
- d. Repeat steps "b" and "c" until zero beat is obtained at both ends of the dial.
- e. Check across the dial at the 100-KC points. If the frequency error is less than 1000 cycles, the VFO calibration is within acceptable limits. If the error exceeds 1000 cycles at any of the mid-points, with the end points at zero error, the VFO condenser should be knifed in. This operation should not be attempted by other than qualified personnel thoroughly familiar with the technique.

NOTE

A receiver covering 5.0 MC to 5.5 MC and having a 100-KC calibrator will be very useful in adjusting the VFO calibration. With the Model SX-115 dial set at the high frequency end (i.e., 4.0 MC, 7.5 MC, etc.), the VFO frequency will be 5.0 MC. L27 is adjusted at this frequency. With the Model SX-115 dial set at 3.5 MC, 7.0 MC, etc., the VFO frequency will be 5.5 MC. Adjust C54 at this point.

5-15. ADJUSTMENT OF T11 (AVC AMPLIFIER CIRCUIT)

Controls should be set as follows:

RF GAIN 10
 AUDIO GAIN 0
 AVC ON
 SELECTIVITY . . . 3 KC
 FUNCTION UPPER SSB/CW
 BAND SELECTOR . 20M
 NOTCH OFF
 XTAL CAL. ON

Adjust TUNING for maximum S meter deflection at any 100-KC check point (antenna disconnected). Back core fully out of coil (T11) by turning counterclockwise until core stops. As the core is turned clockwise into the coil, the "S" meter will gradually decrease and suddenly show a slight increase in reading. This will be the correct adjustment point.

NOTE

The exposed screw threads should measure approximately 3/4 inch at this point.

SECTION VI

SERVICE DATA

6-1. 50.75-KC IF SYSTEM

Figure 14 shows the type of coupling used in the 50.75-KC IF system. Note that inductive

ing "R", the selectivity is made broader. The proper values of "C" and "R" are switched in the circuit by means of the SELECTIVITY control.

capacitance and resistance. By increasing the value of "C" and decreasing "R", the selectivity is made sharper; by decreasing "C" and increas-

tivity control than that readily obtainable by any other method.

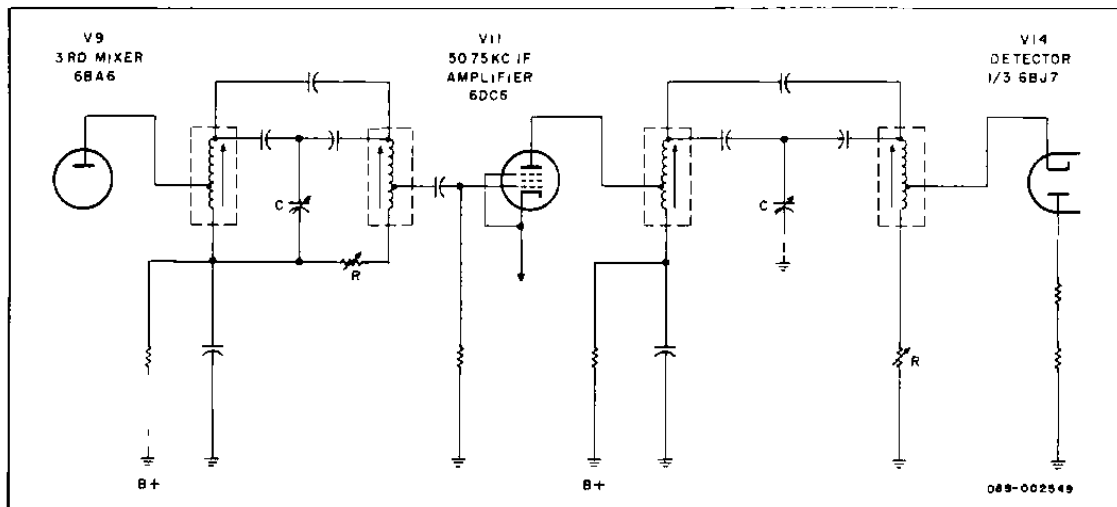

Figure 14. Equivalent Schematic Diagram of the 50.75-KC IF System.

6-2. CHASSIS REMOVAL.

The chassis and front panel assembly are removable from the cabinet as a unit by removing the two screws (top & bottom) at each side of the front panel and the three screws on the underside of the cabinet.

6-3. TUBE AND DIAL LAMP REPLACEMENT.

To gain access to the tubes and dial lamps, raise the hinged top cover of the cabinet. The tube locations and their functions are shown in figure 17.

6-4. RESTRINGING DIAL POINTER MECHANISM.

Remove the chassis from the cabinet (see paragraph 6-2). The procedure for restringing the pointer drive is as follows:

1. Remove the front panel from the chassis by removing knobs (bristol wrench), jacks, meter connections, and two screws from each side of the panel.
2. Remove the band selector dial.
3. Make up dial cord as shown in figure 15.
4. Rotate the BAND SELECTOR control shaft maximum clockwise.
5. Place the loop at the end of the dial cord over the pin (1) on the drum. Following the numerical sequence and arrows as shown in figure 15, string the dial cord and anchor the spring in the chassis hole providing the required tension.
6. Check the spring clearance at the bottom pulley by rotating the BANDSELECTOR shaft fully counterclockwise; the end of the spring should just clear the lower idler pulley and the track mounting screw. This clearance can be obtained by loosening and resetting the drum on the BAND SELECTOR shaft.
7. Rotate the BANDSELECTOR shaft fully clockwise. Place the pointer assembly on the pointer track and engage the dial cord in the clips. Align the top of the pointer with the top of the calibration figure on the 80-meter band (3500 KC to 4000 KC).
8. Replace the band selector dial and index it in the 80-meter position.
9. Rotate the BAND SELECTOR control shaft fully counterclockwise to the 10-meter band (29.5 MC to 30.0 MC) being careful not to shift the pointer along the cord. At the end of travel, the pointer should just clear (and be in line with) the fixed pointer at the dial edge. The pointer must also line up with the center of the dial shaft. This can be adjusted by loosening the pointer-track mounting screws and shifting the track as required.

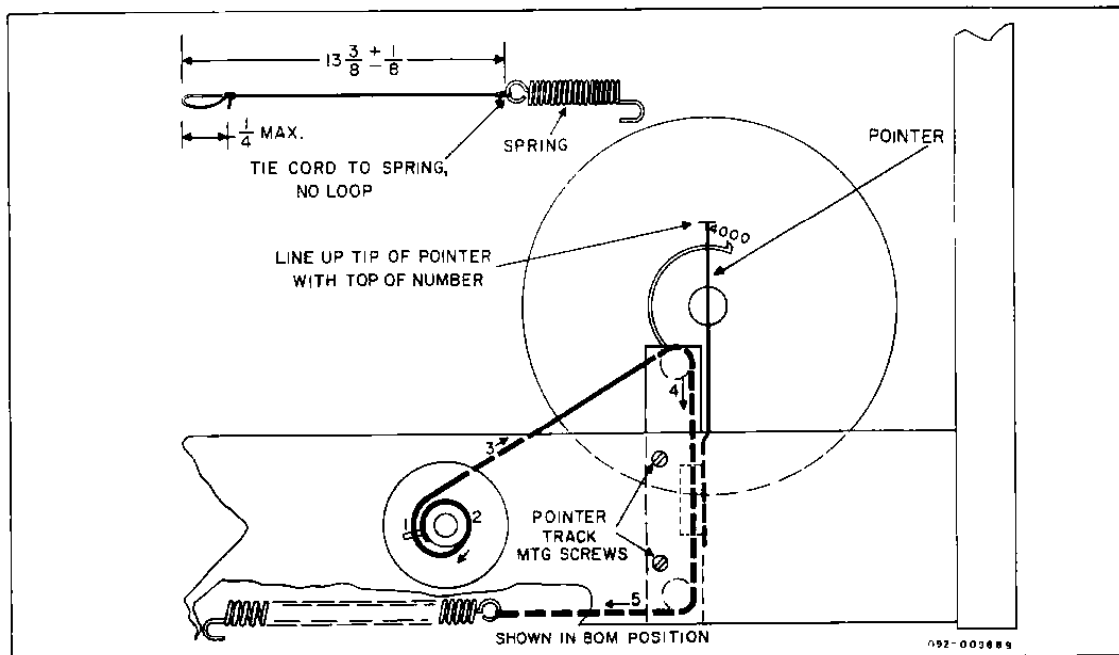

Figure 15. Dial Cord Restringing.

10. Rotate the BAND SELECTOR control shaft fully clockwise. Clinch the pointer clips on the dial cord and apply a drop of household cement to each to prevent slippage. Check the pointer operation. If side play is evident, check the bearing points of the pointer saddle.

Bearing pressure on all four points should be light and even for smooth operation.

11. Reassemble the front panel and install the chassis in the cabinet.

TROUBLE SHOOTING CHART

Symptom	Possible Cause
No output on one sideband	Check V10, incorrect crystal activity adjustment T8 (see Alignment of 955-KC and 1055-KC Third Conversion Oscillators)
No output on one band segment	Incorrect core adjustment (see Adjustment of Crystal Controlled First Conversion Oscillator)
No output SSB/CW only	Check V15 and V16
No output AM only	Check V14
No "S" meter indication	Check V13
No Crystal Calibrator Signal	Check V1
"S" meter reads but no output	Check V15, V16, and V17; shorted speaker terminals; defective speaker
Weak and distorted audio	3.2-ohm and 500-ohm speaker terminals shorted or speaker connected to wrong terminals

6-5. SERVICE OR OPERATION QUESTIONS.

For any further information regarding operation or servicing of the receiver, contact the Hallicrafters dealer from whom the receiver was purchased. The Hallicrafters Company maintains an extensive system of authorized service centers where any required service will be performed promptly and efficiently at nominal charge. All Hallicrafters Authorized Service Centers display the sign shown at right. For the location of the one nearest you, consult your telephone directory.

Do not make any service shipments to the factory unless instructed to do so by letter. The Hallicrafters Company will not accept the responsibility for any unauthorized shipments.

The Hallicrafters Company reserves the privilege of making revisions in current production of equipment and assumes no obligation to incorporate these revisions in earlier models.

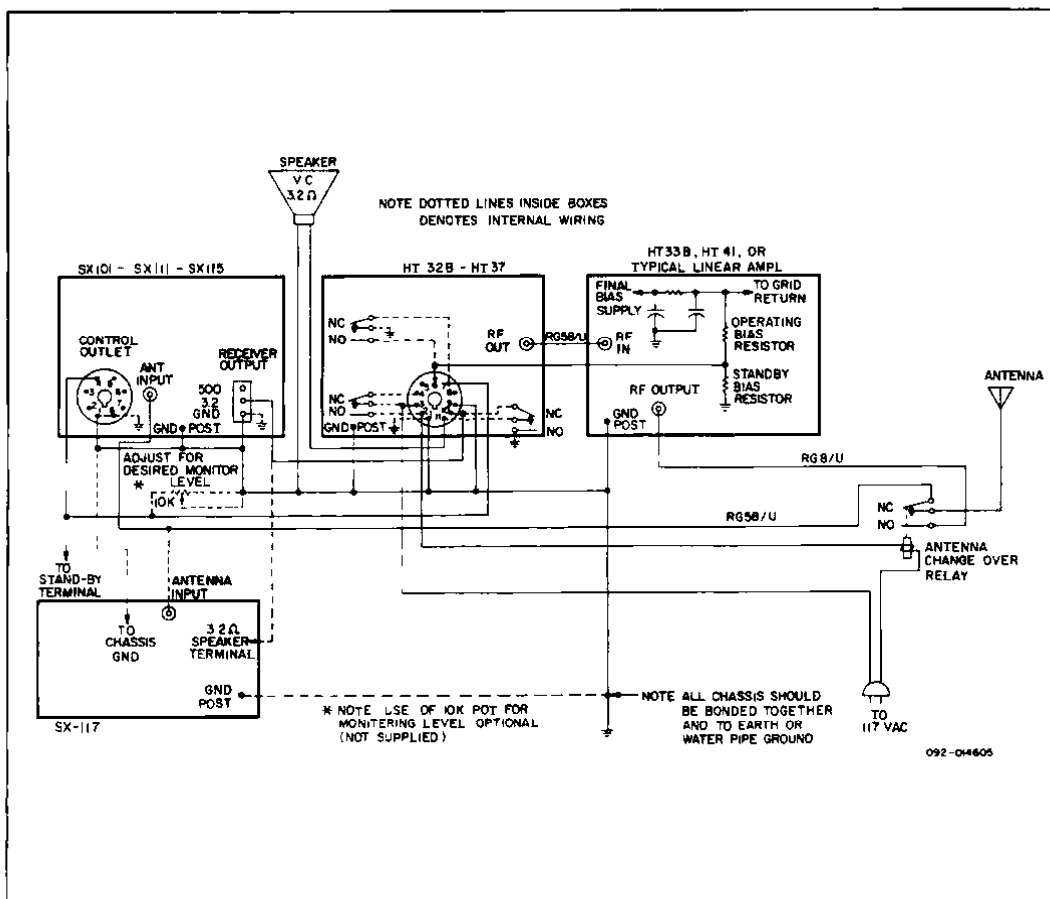

Figure 16. Typical Station Setup.

SERVICE REPAIR PARTS LIST

Schematic Symbol	Description	Hallcrafters Part Number	Schematic Symbol	Description	Hallcrafters Part Number	Schematic Symbol	Description	Hallcrafters Part Number
RESISTORS* (CONT)								
CAPACITORS								
C1	Variable Trimmer 0 mmf to 50 mmf N750	044-200437	C93	5.6 mmf, 2%, 300V Duramica	-81-131056	R76	200 Ohm Variable (S Meter Adj.)	025-001990
C2, 70, 85	2.2 mmf, 10%, Composition	047-200403-04	C94, 95, 119	0.1 mfd, +80%, -20%, 50V Ceramic Disc	047-001146	R77	33K Ohm	451-252333
C3, 34, 35	0.01 mfd, -80%, -20%, 500V Ceramic Disc	047-100224	C96, 98, 105, 109, 120, 126, 127	0.001 mfd, 20%, 500V Ceramic Disc	047-100503	R78, 87	150K Ohm	451-252154
C4	82 mmf, 2%, 300V, Duramica	481-161820	C99	0.047 mfd, 10%, 200V Tubular Mylar	048-001290-04	R81	820K Ohm	451-252824
C5, 12, 23	0.02 mfd, +80%, -20%, 500V, Ceramic Disc	047-100242	C104, 108	0.05 mfd, 50V, Ceramic Disc	047-001144	R82, 83	109 270K Ohm	451-252274
C6	620 mmf, 5%, 300V, Duramica	481-162621	C111	0.0022 mfd, 10%, 400V, Tubular Mylar	046-001308-04	R84, 89	3 3 Ohm 1 watt	451-252033
C7	18 mmf, 5%, 1000V, Duramica	493-410180-241	C112	300 mmf, 2%, 300V, Duramica	-81-161301	R93	500K Ohm Variable (AUDIO GAIN)	025-001965
C8	75 mmf, 5%, 300V, Duramica	481-162750	C117	330 mmf, 2%, 300V, Duramica	481-161331	R95	15 Megohm	451-252156
			C121, 124	100 mmf, 2%, 300V Duramica	481-161101	R99	270 Ohm 1 watt	451-352271
			C122	560 mmf, 2%, 300V, Duramica	481-161561	R101	47 Ohm 1 watt	451-352470
			C123	10 mmf, ±0.5 mmf, N4700, Ceramic Tubular	479-042100	R102	1500 Ohm 5 watt W W	453-042152
			C128	10 mfd, 50V, Electrolytic	045-000755	R103	6800 Ohm	451-252682
						R104	330K Ohm	451-232334
						R105	10K Ohm 2W Variable (RF GAIN)	325-001956
						R106	2000 Ohm 8 watt Candonm	024-101258
						R108	33 Ohm 2 watt	451-652330
						* All RESISTORS carbon type, 10% 1/2 watt, unless otherwise stated		
COILS								
18, 19, 20, 30, 31, 119	Ceramic Disc		C135	Variable, Differential	048-200375	L6	Antenna (20M)	051-003994
C15	0.001 mfd, GMV, 500V, Ceramic Disc	047-200230	C138	0.01 mfd, 20%, 500V Ceramic Disc	047-100354	L7	Antenna (15M)	051-003095
C16	9 mmf, ±0.5 mmf, 300V, Duramica	481-135090				L8	Antenna (10M)	051-003096
C17	470 mmf, 5%, 300V, Duramica	481-162471	RESISTORS*			L9	RF Choke, 2.5MH	053-200335
C21, 22	47 mmf, 5%, 500V, N3300, Ceramic Tubular	479-035470	R1, 4, 70, 79, 94	220K Ohm	451-252224	L10	Mixer (WWV)	051-003099
C23	56 mmf, 5%, 300V, Duramica	481-162560	R2	4700 Ohm	451-252472	L11	Mixer (80M)	051-003097
C24	100 mmf, 5%, 300V, Duramica	481-162101	R3, 39, 47, 48, 49, 50	100K Ohm	451-252104	L12	Mixer (40M)	051-003098
C25	56 mmf, 5%, 300V, Duramica	481-162560	R5, 8, 11, 14, 17, 21, 31, 41, 45, 46, 49, 54, 55, 56, 57, 58, 59, 62, 96	22K Ohm	451-252223	L13	Mixer (20M)	051-003100
C26	47 mmf, 5%, 300V, Duramica	481-152470	R9, 37, 42	22K Ohm 1 watt	451-352223	L14	Mixer (15M)	051-003101
C27	15 mmf, 5%, 300V, Duramica	481-132150	R10, 20, 22	2700 Ohm	451-252272	L15	Mixer (10M)	051-003102
C32, 37	175 mmf, 5%, 300V, Duramica	493-121750-224	43, 69			L16, 33	RF Choke, 0.7MH	053-000520
C33A, B	Variable, TUNING	048-000506	R6, 19, 54, 85, 75, 80, 87, 25, 30, 40, 55, 59, 62, 96	1 Megohm	451-252105	L17	Filament Choke	053-200427
C39, 41, 60, 61, 71, 72	560 mmf, 5%, 300V, Duramica	481-162561	R27, 100, 220, 29	180 Ohm	451-252181	L18	Oscillator (WWV)	051-003105
C42, 52, 100, 130	0.22 mfd, 10%, 200V, Tubular Mylar	046-001298-04	R33, 37, 42	22K Ohm 1 watt	451-352223	L20, 24	Oscillator (40M and 10M)	051-003104
C43, 116, 136	15 mmf, 2%, 300V, Duramica	461-131150	R38, 58, 90	1000 Ohm	451-252102	L21, 26	Oscillator (20M and 10M)	051-003106
C44	5 mmf, 10%, NPO, Ceramic Tubular	491-006060-22	R44	2200 Ohm	451-252222	L22, 25	Oscillator (15M and 10M)	051-003107
C45, 46	47 mmf, 5%, N80, Ceramic Tubular	491-105470-42	R45	120K Ohm	451-252124	L27	VFO	051-202180
C47, 114, 125, 140	470 mmf, 2%, 300V, Duramica	481-161471	R52	3200 Ohm	451-252681	L28	VFO Filament	053-200359
C48, 49	0.001 mfd, 5%, 300V, Mica	047-100823	R53	5000 Ohm, Variable (Notch Depth)	025-201716	L29	Filament Choke	053-200427
C50, 57	0.01 mfd, 10%, 300V, Mica	470-843103	R56	39K Ohm 1 watt	451-352393	L30	RF Choke 540UH	053-100107
C51	12 mmf, 5%, N1500, Ceramic Tubular	479-015120	R57	3300 Ohm	451-252392	L31, 32	RF Choke	053-200098
C52	12 mmf, 5%, NFO, Ceramic Tubular	491-005120-22	R60, 63	220 Ohm	451-252221	L34	Drudge T (NOTCH FREQ)	051-202270
C53	Variable, TUNING, 9.5 mmf to 22.5 mmf	048-000481	R61, 64	390 Ohm	451-252391	L35	Filter Choke	056-000531
C54	Variable, Trimmer, 2.8 mmf to 13.3 mmf	048-200375	R66	330 Ohm	451-252184	L36	VFO (PITCH)	054-200053
C55	18 mmf, 5%, N80, Ceramic Tubular	491-005180-42	R67	180K Ohm	451-252225	TRANSFORMERS		
C56	100 mmf, 10%, N750, Ceramic Tubular	491-026101-04	R71	2.2 Megohm	025-001957	T1, 2	IF (6-6.5MC)	050-000770
C58, 69	390 mmf, 5%, 500V, Duramica	482-262391	R74	2 Megohm, Variable (S Meter Sens.)		T3	VFO Band Pass Filter	050-200679
C78, 97, 107	220 mmf, 2%, 300V Duramica	481-161221				T4, 5	IF (1005KC)	050-000768
C79, 80	7500 mmf, 5%, 500V, Mica	470-422752				T6, 7, 9, 10, 11	IF (50, 75KC)	050-200735
C83, 84	390 mmf, 2%, 300V, Duramica	481-161391				T8	Oscillator (955-1055KC)	050-000769
C87, 90	4700 mmf, 10%, 500V, Ceramic Disc	047-001506				T12	Audio Output	055-000449
C88, 89, 91	0.01 mfd, 10%, 500V, Ceramic Disc	047-001505				T13	Power	052-000883
92						CRYSTALS		
						X1	100KC Quartz	019-002712
						X2	16.105MC Quartz	019-002720
						X3	10.1055MC Quartz	019-002727
						X4	19.505MC Quartz	019-002728
						X5	20.505MC Quartz	019-002730
						X6	27.505MC Quartz	019-002731
						X7	34.505MC Quartz	019-002732
						X8	35.005MC Quartz	019-002733
						X9	35.505MC Quartz	019-002734
						X10	36.005MC Quartz	019-002735
						X11, 12	955-1055KC (Matched Pair)	019-002719
						DIODES		
						CR1, 2, 3	HD6225	019-002354
						CR4, 5	Special	027-000308

