

Hallicrafters, Inc.

Model: SX-17, Early

Chassis:

Year: Pre October 1938

Power:

Circuit:

IF:

Tubes:

Bands:

Resources

[Riders Volume 9 - HALLICRAFTERS 9-7](#)

[Riders Volume 9 - HALLICRAFTERS 9-8](#)

[Riders Volume 9 - HALLICRAFTERS 9-9](#)

[Riders Volume 9 - HALLICRAFTERS 9-10](#)

HALLICRAFTERS, INC.

MODEL SX-17 Early Super Skyrider Schematic, Changes

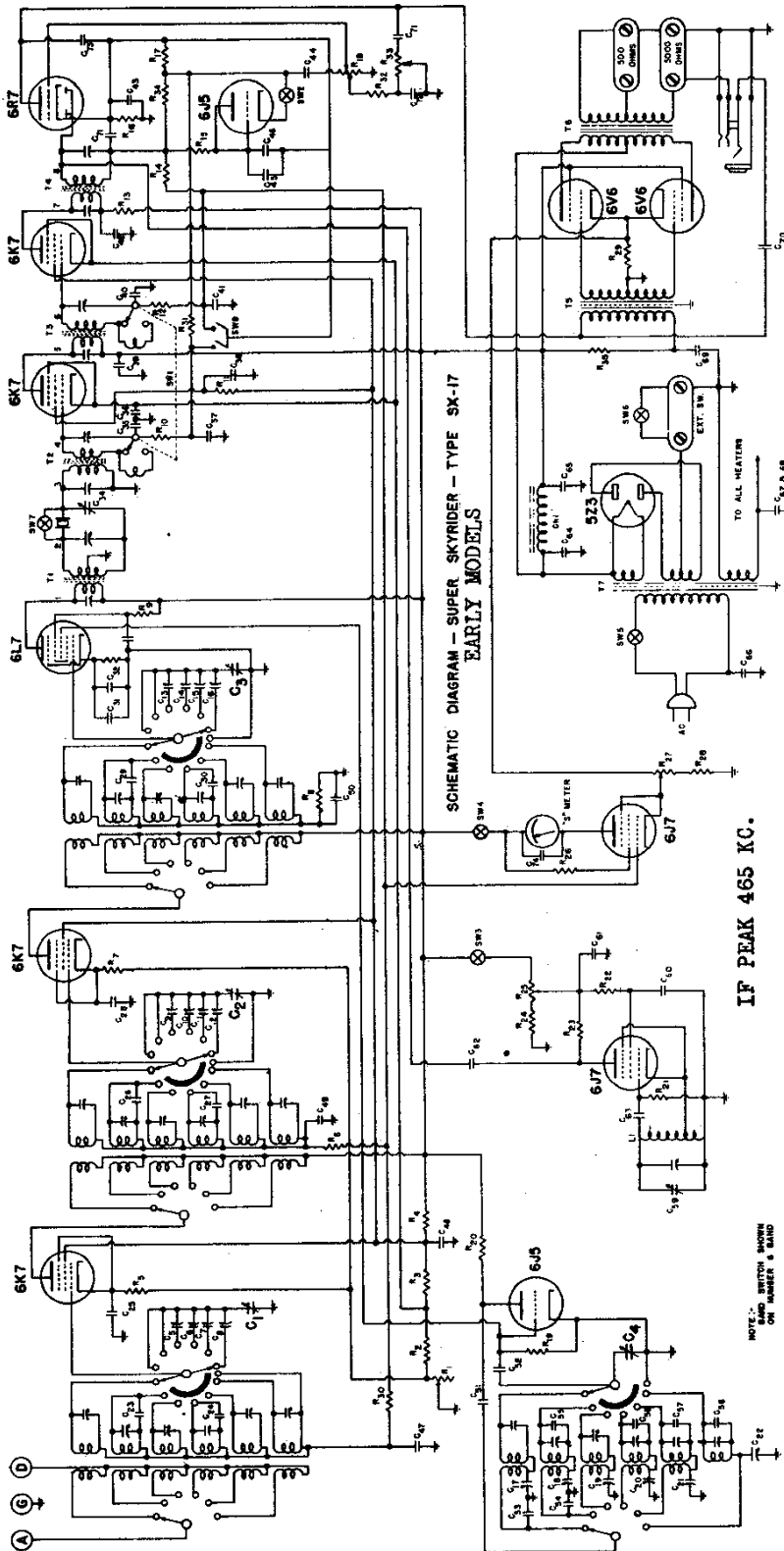

This unit has been constructed on special order. In outward appearance it is identical to the SX-16 Model. The differences in the two receivers consists of a second R.F. stage and a noise silencer. These additions make the total number of tubes in the receiver 15.

FOR ALIGNMENT SEE S-17, SX-17 LATE MODELS CHANGES FOUND IN SOME EARLY MODELS WHICH PRECEDE THE SX-17 LATE MODELS.

- R14- 1 meg.
- R15- 1meg.
- R16- 950 ohms.
- R17- 250 ohms.
- R34- 100M ohms.
- C44-.05 mfd. 200v.
- C45-.1 mfd. 200v.
- C46-.002 mfd. mica.

NOTE: -
- AND SWITCH SHOWN
ON "MUSIC" & "TUNE"

HALLICRAFTERS, INC.

MODELS S-17, SX-17
Super Skyrider
Alignment, Voltage

F. Alignment Procedure

LAST, USE A .0002 MFD CONDENSER IN SERIES WITH THE
ERATOR TO RECEIVER. ON THE OTHER BANDS USE A 400
RE JUMPER FROM DOUBLET POST TO GND. REMAINS CONNECTED
:EIVER.
: LOCATED ON THE TOP OF THE CHASSIS) ARE FOR THE LOW
: BANDS.
ITS (LOCATED ON THE BOTTOM OF THE CHASSIS) ARE FOR
: OS OF THE BANDS.
: CONTROL BELOW THE POINT OF BLOCKING OR OVERLOADING;
: CRYSTAL SWITCH IS IN THE "OUT" POSITION AS WELL
: IN THE "OFF" POSITION.
: ES - IMAGES WILL FALL A LITTLE LESS THAN 1,000 KC
: AN THE FUNDAMENTAL OR HARMONIC OF THE SIGNAL FROM
: BE OF THE TWO RF STAGES IMAGES WILL BE GREATLY
: ISON TO A UNIT WITH ONE STAGE OF RF.
: BE ROCKED WHEN MAKING THESE ADJUSTMENTS.

SUITABLE FREQUENCIES MAY BE USED IF THE FOLLOWING
: QUENCIES ARE NOT AVAILABLE.

TRY TO REPEAT EACH PAIR OF OPERATIONS SEVERAL TIMES
: GE IS NOTED.

OULD BE EXERCISED IN ALIGNING AND ACCURATELY
: CH CIRCUIT IN THE SPECIAL SUPER SKYRIDER; OTHERWISE
: WILL BE CUMULATIVE AND THE SET WILL FUNCTION POORLY.

CRYSTAL OPERATION

JUST THE CRYSTAL CIRCUIT FOR BEST PERFORMANCE THE
: SHOULD BE CAREFULLY FOLLOWED:

ITCH IN THE "OFF" POSITION. TUNE IN SOME STATION
: BLY. BE VERY CAREFUL TO GET THE SIGNAL RIGHT ON
: ARE SURE THAT YOU HAVE THE SIGNAL RESONATED
: HE "BFO INJECTOR" CONTROL AND LEAVE THE POINTER
: TICAL POSITION. YOU SHOULD HEAR A WHISTLE, OR
: E BFO IS ON ROTATION OF THE "PITCH CONTROL" WILL
: HE BEAT NOTE. PROPER OPERATION OF THIS CONTROL
: HEARING THE SIGNAL TWICE IN ONE COMPLETE ROTATION
: ING TWO POSITIONS AT WHICH NO SIGNAL, OR WHISTLE,
: E TWO POSITIONS ARE KNOWN AS THE "ZERO BEAT"

RYSTAL" SWITCH TO THE "ON" POSITION. YOU WILL
: A NOISE. CAREFULLY RETUNE THE SIGNAL USING THE
: DICE NOW SHARPLY THE SIGNAL PEAKS. NOW TUNE
: ND FIND WHICH SIDE OF THE SIGNAL IS THE WEAKER.
: ODE AND THEN CAREFULLY ADJUST THE "CRYSTAL PHASING"
: SHAL IS INAUDIBLE. GOING BACK TO THE OTHER SIDE
: FING NO CHANGE IN ITS ORIGINAL VOLUME, AND KNIFE-
: ALTING NO USE WHICHEVER SIDE OF ZERO-BEAT ADJUSTMENT
: LT. IN CONJUNCTION WITH CRITICAL ADJUSTMENT OF THE
: ES THE GREATER REJECTION OF THE INTERFERING SIGNAL.
: ASING CONTROL AFFECTS THE SENSITIVITY AND SELECTIVITY
: HER THE CRYSTAL IS IN THE CIRCUIT OR NOT.

HALLICRAFTERS, INC.

MODELS S-17, SX-17
 Super Skyrider
 Socket, Trimmers
 Alignment, Parts

OPR.	BAND	RECEIVER DIAL SETTING	SIGNAL GENERATOR FREQUENCY WITH	ADJUST OSC. WITH	TRIMMERS ADJ. FOR MAX GAIN	ADJUST OSC. FOR MAX GAIN	PADDERS
1	1	600KC	600KC	CA	CB CC CD	C22	
2	1	1400KC	1400KC	CE	CF CG CH	C21	
3	2	1800KC	1800KC	C1	CJ CK CL	C19	C5 C9 C13
4	2	4000KC	4000KC	CM	CN CO CP	C20	C6 C10 C14
5	3	5000KC	5000KC	CQ	CR CS CT	C18	C7 C11 C15
6	3	9000KC	9000KC	CU		C17	C16
7	4	10,000KC	10,000KC				
8	4	18,000KC	18,000KC				
9	5	20,000KC	10,000KC				
10	5	30,000KC	10,000KC				
11	6	40,000KC	20,000KC				
12	6	60,000KC	20,000KC				

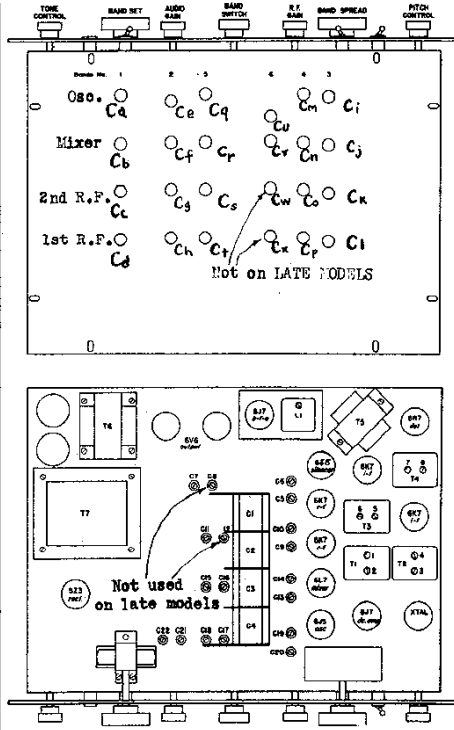

- SWITCHES
- 1 SELECTIVITY DPDT
 - 2 NOISE SILENCER SPST
 - 3 BFO (MOUNTED ON CONTROL)
 - 4 1/2" METER (MOUNTED ON R.F. GAIN CONTROL)
 - 5 A.C. OFF AND ON (MOUNTED ON TONE CONTROL)
 - 6 SEND RECEIVE SPST
 - 7 CRYSTAL SPST
 - 8 AVC DPST

SKYRIDER CAPACITY	MODELS S-17, SX-17	TYPE	VOLTAGE	NO.	CAPACITY	TYPE	VOLTAGE	PARTS No.
420 MMFD	48-018	"	600	60	.01 MFD	"	600	45-002
"	"	"	600	61	"	"	600	45-002
100	44-019	"	400	62	.01 MFD	"	400	40-021
100	"	"	400	63	.00025 MFD	"	400	40-024
310	44-020	"	600	64	.01	"	600	42-019
880	"	"	600	65	.002	"	600	45-002
400	44-018	"	400	66	.002	"	400	40-013
590	"	"	400	67	.002	"	400	40-013
000	44-017	"	600	68	.01	"	600	41-013
350	"	"	600	69	.0001	"	600	45-002
400	44-018	"	600	70	.0005	"	600	40-003
590	"	"	600	71	.0005	"	600	45-009
350	44-017	"	600	72	.0005	"	600	43-008
000	"	"	600	73	.0005	"	600	40-019
180	44-017	"	600	74	.002	"	600	40-021
350	"	"	600	75	10 MMFD	"	600	40-021
120	44-016	"	600	76	50	"	600	40-002
000	"	"	600	77	.02 MFD	"	600	45-010
350	44-017	"	600	78	.05	"	600	41-005
180	"	"	600	79	.002	"	600	41-007
120	44-016	"	600	80	.002	"	600	40-013
10	"	"	600	81	10 MMFD	"	600	40-021
10	40-021	"	600	82	10 MMFD	"	600	40-021
10	40-021	"	600	83	10 MMFD	"	600	40-021
002 MFD	40-013	"	600	84	.05 MFD	"	600	45-007
10 MMFD	40-021	"	600	85	10 MMFD	"	600	40-021
002 MFD	40-021	"	600		10 MMFD	"	600	40-021
10 MMFD	40-013	"	600		10 MMFD	"	600	40-021
10	40-021	"	600		10 MMFD	"	600	40-021
10	40-013	"	600		10 MMFD	"	600	40-021
002 MFD	40-021	"	600		10 MMFD	"	600	40-021
10	40-013	"	600		10 MMFD	"	600	40-021
002 MFD	40-021	"	600		10 MMFD	"	600	40-021
10	40-013	"	600		10 MMFD	"	600	40-021
002 MFD	40-021	"	600		10 MMFD	"	600	40-021
10	40-013	"	600		10 MMFD	"	600	40-021
002 MFD	40-021	"	600		10 MMFD	"	600	40-021
10	40-013	"	600		10 MMFD	"	600	40-021
002 MFD	40-021	"	600		10 MMFD	"	600	40-021
10	40-013	"	600		10 MMFD	"	600	40-021
002 MFD	40-021	"	600		10 MMFD	"	600	40-021
10	40-013	"	600		10 MMFD	"	600	40-021
002 MFD	40-021	"	600		10 MMFD	"	600	40-021
10	40-013	"	600		10 MMFD	"	600	40-021
002 MFD	40-021	"	600		10 MMFD	"	600	40-021
10	40-013	"	600		10 MMFD	"	600	40-021
002 MFD	40-021	"	600		10 MMFD	"	600	40-021
10	40-013	"	600		10 MMFD	"	600	40-021
002 MFD	40-021	"	600		10 MMFD	"	600	40-021
10	40-013	"	600		10 MMFD	"	600	40-021
002 MFD	40-021	"	600		10 MMFD	"	600	40-021
10	40-013	"	600		10 MMFD	"	600	40-021
002 MFD	40-021	"	600		10 MMFD	"	600	40-021
10	40-013	"	600		10 MMFD	"	600	40-021
002 MFD	40-021	"	600		10 MMFD	"	600	40-021
10	40-013	"	600		10 MMFD	"	600	40-021
002 MFD	40-021	"	600		10 MMFD	"	600	40-021
10	40-013	"	600		10 MMFD	"	600	40-021
002 MFD	40-021	"	600		10 MMFD	"	600	40-021
10	40-013	"	600		10 MMFD	"	600	40-021
002 MFD	40-021	"	600		10 MMFD	"	600	40-021
10	40-013	"	600		10 MMFD	"	600	40-021
002 MFD	40-021	"	600		10 MMFD	"	600	40-021
10	40-013	"	600		10 MMFD	"	600	40-021
002 MFD	40-021	"	600		10 MMFD	"	600	40-021
10	40-013	"	600		10 MMFD	"	600	40-021
002 MFD	40-021	"	600		10 MMFD	"	600	40-021
10	40-013	"	600		10 MMFD	"	600	40-021
002 MFD	40-021	"	600		10 MMFD	"	600	40-021
10	40-013	"	600		10 MMFD	"	600	40-021
002 MFD	40-021	"	600		10 MMFD	"	600	40-021
10	40-013	"	600		10 MMFD	"	600	40-021
002 MFD	40-021	"	600		10 MMFD	"	600	40-021
10	40-013	"	600		10 MMFD	"	600	40-021
002 MFD	40-021	"	600		10 MMFD	"	600	40-021
10	40-013	"	600		10 MMFD	"	600	40-021
002 MFD	40-021	"	600		10 MMFD	"	600	40-021
10	40-013	"	600		10 MMFD	"	600	40-021
002 MFD	40-021	"	600		10 MMFD	"	600	40-021
10	40-013	"	600		10 MMFD	"	600	40-021
002 MFD	40-021	"	600		10 MMFD	"	600	40-021
10	40-013	"	600		10 MMFD	"	600	40-021
002 MFD	40-021	"	600		10 MMFD	"	600	40-021
10	40-013	"	600		10 MMFD	"	600	40-021
002 MFD	40-021	"	600		10 MMFD	"	600	40-021
10	40-013	"	600		10 MMFD	"	600	40-021
002 MFD	40-021	"	600		10 MMFD	"	600	40-021
10	40-013	"	600		10 MMFD	"	600	40-021
002 MFD	40-021	"	600		10 MMFD	"	600	40-021
10	40-013	"	600		10 MMFD	"	600	40-021
002 MFD	40-021	"	600		10 MMFD	"	600	40-021
10	40-013	"	600		10 MMFD	"	600	40-021
002 MFD	40-021	"	600		10 MMFD	"	600	40-021
10	40-013	"	600		10 MMFD	"	600	40-021
002 MFD	40-021	"	600		10 MMFD	"	600	40-021
10	40-013	"	600		10 MMFD	"	600	40-021
002 MFD	40-021	"	600		10 MMFD	"	600	40-021
10	40-013	"	600		10 MMFD	"	600	40-021
002 MFD	40-021	"	600		10 MMFD	"	600	40-021
10	40-013	"	600		10 MMFD	"	600	40-021
002 MFD	40-021	"	600		10 MMFD	"	600	40-021
10	40-013	"	600		10 MMFD	"	600	40-021
002 MFD	40-021	"	600		10 MMFD	"	600	40-021
10	40-013	"	600		10 MMFD	"	600	40-021
002 MFD	40-021	"	600		10 MMFD	"	600	40-021
10	40-013	"	600		10 MMFD	"	600	40-021
002 MFD	40-021	"	600		10 MMFD	"	600	40-021
10	40-013	"	600		10 MMFD	"	600	40-021
002 MFD	40-021	"	600		10 MMFD	"	600	40-021
10	40-013	"	600		10 MMFD	"	600	40-021
002 MFD	40-021	"	600		10 MMFD	"	600	40-021
10	40-013	"	600		10 MMFD	"	600	40-021
002 MFD	40-021	"	600		10 MMFD	"	600	40-021
10	40-013	"	600		10 MMFD	"	600	40-021
002 MFD	40-021	"	600		10 MMFD	"	600	40-021
10	40-013	"	600		10 MMFD	"	600	40-021
002 MFD	40-021	"	600		10 MMFD	"	600	40-021
10	40-013	"	600		10 MMFD	"	600	40-021
002 MFD	40-021	"	600		10 MMFD	"	600	40-021
10	40-013	"	600		10 MMFD	"	600	40-021
002 MFD	40-021	"	600		10 MMFD	"	600	40-021
10	40-013	"	600		10 MMFD	"	600	40-021
002 MFD	40-021	"	600		10 MMFD	"	600	40-021
10	40-013	"	600		10 MMFD	"	600	40-021
002 MFD	40-021	"	600		10 MMFD	"	600	40-021
10	40-013	"	600		10 MMFD	"	600	40-021
002 MFD	40-021	"	6					