

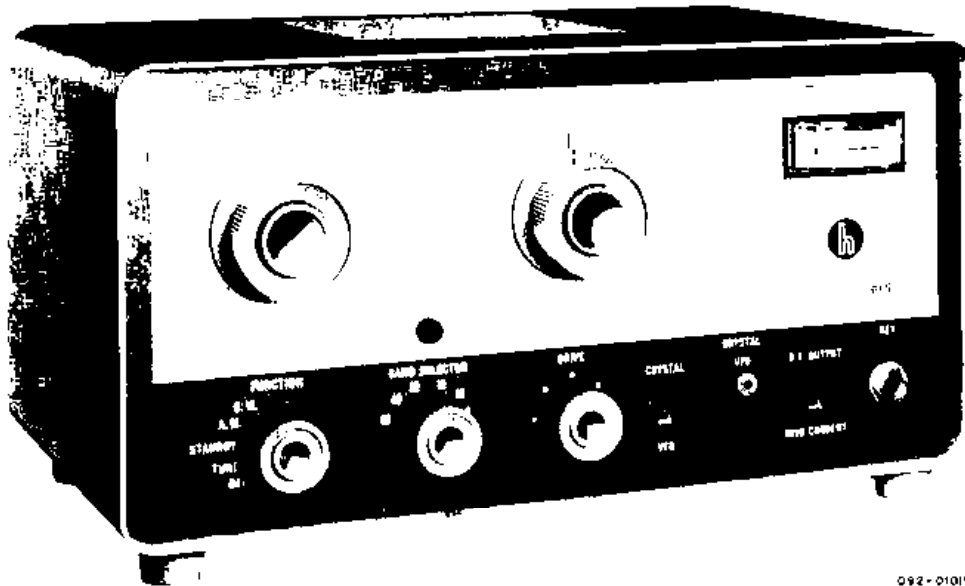

the hallicrafters co.

MANUFACTURERS OF ELECTRONIC EQUIPMENT, CHICAGO 24, U. S. A.



092-010196

Figure 1. Hallicrafters Model HT-40 Transmitter

SECTION I GENERAL DESCRIPTION

1-1. INTRODUCTION

The Hallicrafters Model HT-40 is a four-tube self contained Transmitter capable of AM (amplitude modulated) and CW (continuous wave) transmission on the 80, 40, 20, 15, 10, and 6 meter bands. The only requirements for immediate "on the air" operation are a 50 to 75 ohm terminated antenna, a crystal or external VFO, a key or microphone and a 117 volt, 60 CPS, AC power source.

1-2. T.V.I. SUPPRESSION

The HT-40 has been designed and con-

final amplifier. The tuned output circuit is a pi network that has excellent inherent harmonic suppression capability. The pi network is connected to a coaxial connector and permits the use of any antenna system having an impedance of 50 to 75 ohms.

The Model HT-40 Transmitter, as received from the factory, has every advantage of Hallicrafters advanced engineering to minimize television interference. There are, however, some types of T.V.I. that cannot be prevented within the transmitter itself. For example, when a television receiver is located in the immediate vicinity of the Transmitter it is entirely possible that a funda-

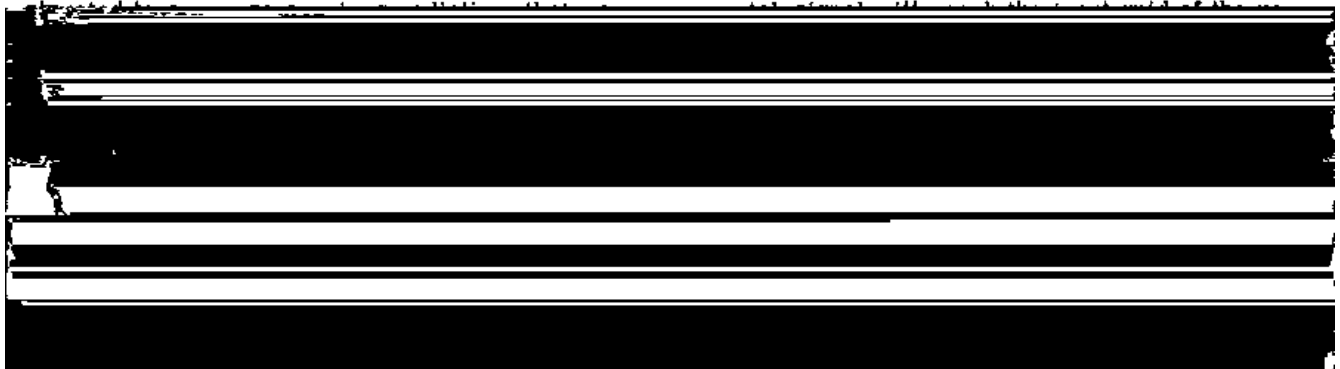

SECTION II TECHNICAL DATA

TYPES OF EMISSION

	75 watts maximum
AUDIO INPUT004 V minimum at input to microphone jack
DISTORTION8% at 75% modulation
HUM AND NOISE OUTPUT.40 db or more below maximum output
TUBES	Four, plus two silicon rectifiers
POWER SOURCE.	105-125 volts, 60 CPS, AC
OUTPUT COUPLING.	Pi network
POWER CONSUMPTION	175 watts
RF OUTPUT IMPEDANCE	50 to 75 ohm coaxial, connector accepts Amphenol 83-ISP connector
CW KEYING	Panel mounted key jack accepts standard 2-connector 1/4" plug
MICROPHONE INPUT	Rear chassis mounted microphone receptacle Amphenol 75-MCIF connector
DIMENSIONS	7-3/16" high, 13-3/8" wide, 8-1/4" deep
NET WEIGHT	17 pounds
SHIPPING WEIGHT.	19 pounds

FREQUENCY COVERAGE

Band	Transmitter Frequency Range	Crystal or VFO Frequency Range
80	3.5 MC to 4 MC	3500 KC to 4000 KC
40	7 MC to 7.3 MC	3500 KC to 3650 KC 7000 KC to 7300 KC
20	14 MC to 14.35 MC	7000 KC to 7175 KC
15	21 MC to 21.45 MC	7000 KC to 7150 KC
10	28 MC to 29.7 MC	7000 KC to 7425 KC
6	50 MC to 54 MC	8333 KC to 9000 KC

Note: 1000 KC = 1 MC

SECTION III INSTALLATION

3-1. UNPACKING

After unpacking the HT-40 Transmitter, examine it closely for any possible damage which may have occurred during transit. Should any sign of damage be apparent, file a claim immediately with the carrier stating the extent of damage. Carefully check all shipping labels and tags for special instructions before removing or destroying them.

3-2. LOCATION

The unit should be placed in a location that provides adequate space around it, to permit free circulation of air through the cabinet openings. Avoid excessively warm locations such as those on or near radiators and heating vents.

3-3. POWER SOURCE

The HT-40 Transmitter is designed to operate on 105 to 125 volt, 60 cycle AC current. Power consumption is 175 watts.

IMPORTANT: If in doubt about the power source, contact your local power company prior to inserting the power plug into an AC power outlet. Plugging the power cord into the wrong power source can cause extensive damage to the unit, requiring costly repairs.

3-4. CRYSTAL - VFO RECEPTACLE

The CRYSTAL-VFO receptacle consists of two pin jacks, mounted on the front panel, to accommodate .093" diameter pins with 1/2" center separation (similar to type FT-243 crystal holder).

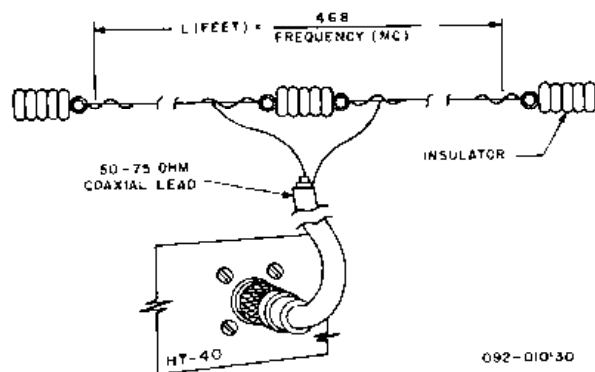

Figure 2. Coaxial Fed Half-Wave
Dipole Antenna

When an external VFO is used connect the high or "hot" side of the VFO output to the red pin jack and the ground side to the black pin jack.

3-5. KEY RECEPTACLE

The KEY jack, a standard two conductor closed circuit type jack located on the front panel, provides for the connection of a hand keyer, a "bug" or an automatic keyer (T.O. Keyer). In addition to the KEY jack the keying instrument may be connected to terminals 3 and 4 of the four terminal strip located on the rear of the chassis. These contacts are connected in parallel with the KEY jack when the plug is removed from the jack (see para. 3-8).

3-6. MICROPHONE CONNECTOR

The microphone connector, located on the rear of the chassis, is an Amphenol type 75-PC1M bulkhead receptacle and will accept an Amphenol type 75-MC1F microphone plug.

3-7. ANTENNAS

It is suggested that a half-wave dipole antenna fed with a 50-ohm coaxial cable be used to radiate maximum power from the HT-40 (see fig. 2). Refer to the ARRL ANTENNA HANDBOOK or similar publications for detailed information concerning transmitting antennas.

3-8. ACCESSORY TERMINAL STRIP

A four-terminal strip on the rear of the chassis permits connecting the HT-40 to auxiliary equipments.

The FUNCTION switch in the AM or CW position electrically connects terminals 1 and 2. When the FUNCTION switch is in either the OFF, TUNE or STANDBY position these terminals are not electrically connected. When terminals 1 and 2 are connected to auxiliary equipment such as an antenna change-over relay the FUNCTION switch controls the operation of the relay (see fig. 3).

Terminals 3 and 4 connected across (in parallel with) the key jack terminals, when the plug is removed from the KEY jack, permits the HT-40 to be connected to a remote control switching device such as the SX-140 Receiver, a remote control switch or separate leads from the push-to-talk switch on the microphone (see fig. 4). The HT-40 may be keyed by connecting a key to terminals 3 and 4. For remote control operation or keying from these terminals the key plug must be removed from the KEY jack and the shorting wire removed from terminals 3 and 4.

SECTION IV OPERATING CONTROLS

4-1. FUNCTION CONTROL

The FUNCTION control, a five-position rotary switch is used to select the Transmitter mode of operation as indicated.

1. OFF position; AC power is disconnected from the power transformer primary.
2. TUNE position; power is applied to the oscillator and buffer stages but not to the modulator and final amplifier stages. Grid current is adjusted with the DRIVE control for maximum indication on the RF OUTPUT - GRID CURRENT meter.

3. STANDBY position; the negative side of the DC power supply is disconnected from the internal circuitry. Provision is made for remote control switching, refer to paragraph 3-8.

NOTE

A unique feature of the power supply allows current to be constantly fed through the bleeder when in the STANDBY position, thus providing better voltage regulation when switching from STANDBY to AM or CW.

4. AM position; power is applied to the oscillator, buffer, speech amplifier, final amplifier and modulator stages.

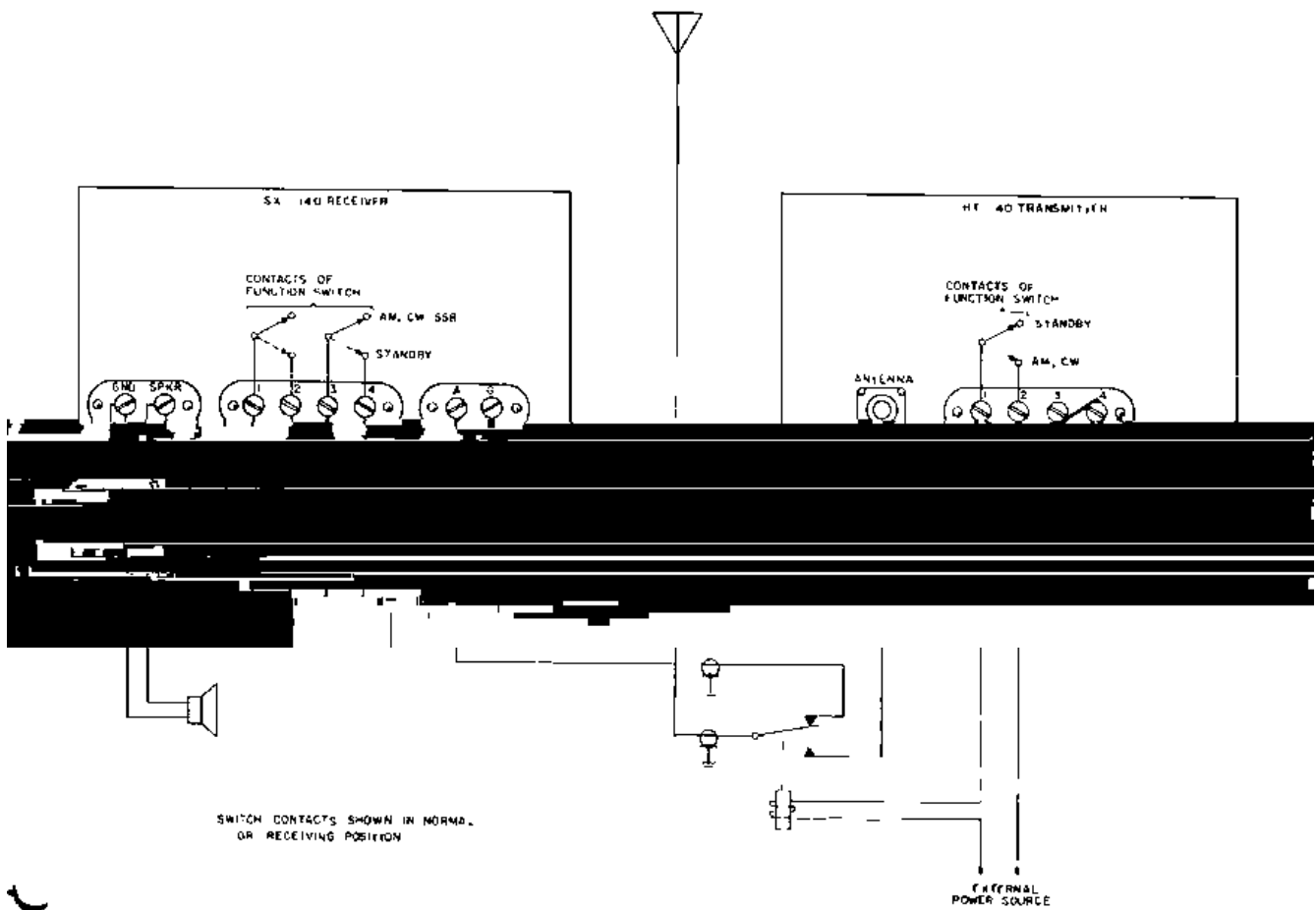

Figure 3. Model HT-40 Controlling Antenna Relay

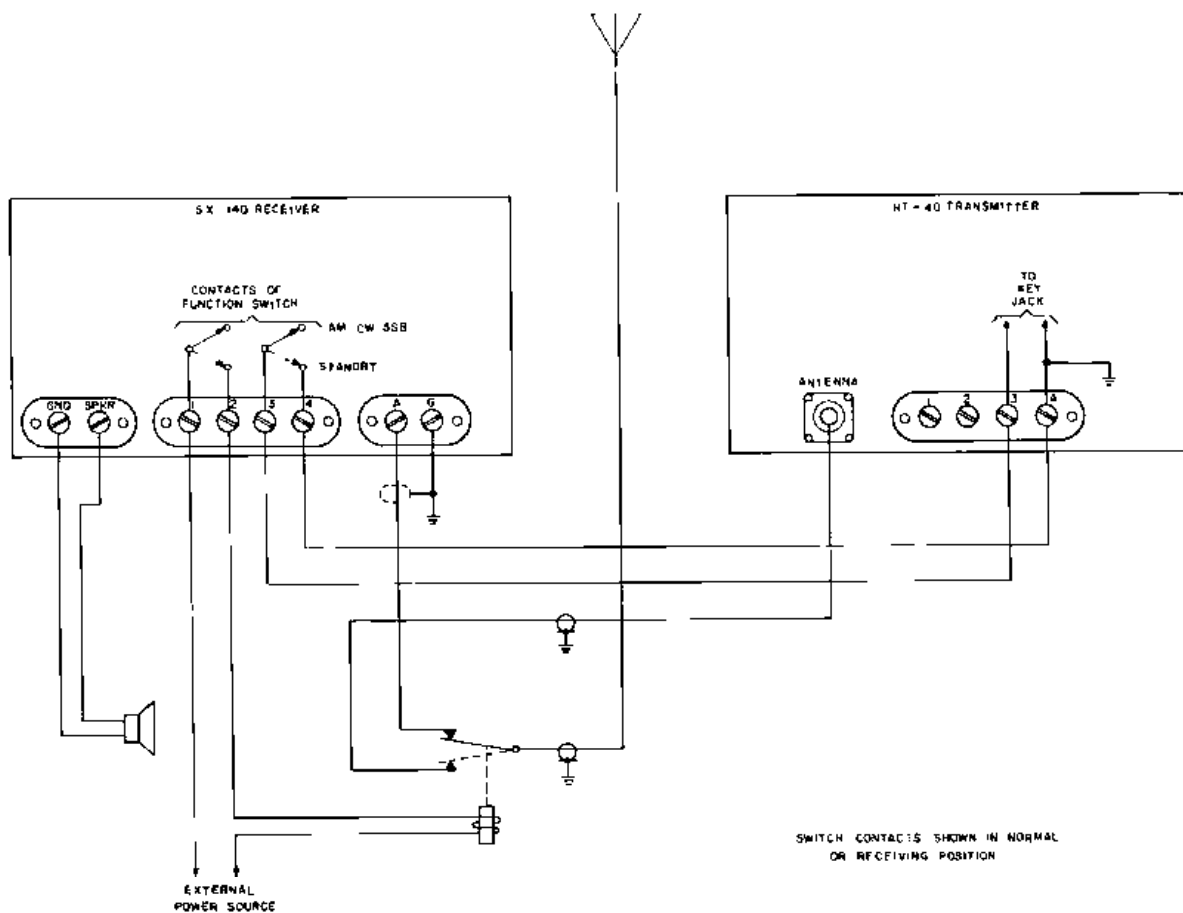

Figure 4. Model HT-40 Controlled By Station Receiver

5. CW position; power is applied to the oscillator, buffer and final amplifier stages but is removed from the modulator stage. Screen voltage for the 6DQ5 is obtained from the tap on the bleeder connected across the power supply.

4-2 BAND SELECTOR CONTROL

The BAND SELECTOR is a six-position multi-section rotary switch used to select the proper inductance in the driver and final amplifier pi network for each band.

4-3. DRIVE CONTROL

The DRIVE control is a variable capacitor used to tune the plate circuit of the buffer stage. This control also functions as the input tuning capacitor of the pi network between the output of the buffer stage and the input to the final amplifier stage. Operation of this control is such that it is impossible to tune to a harmonic of the desired

output frequency.

4-4. CRYSTAL-VFO SWITCH

The CRYSTAL-VFO switch is a SPDT slide switch which permits the HT-40 to operate either crystal controlled or to operate from an external VFO.

4-5. RF OUTPUT-GRID CURRENT SWITCH

The RF OUTPUT-GRID CURRENT switch is a DPDT slide switch which permits the operator to switch the meter either into the grid circuit of the final amplifier (6DQ5) or across the RF output load.

4-6. PLATE LOADING CONTROL

The PLATE LOADING control is a variable capacitor in the output of the pi network section which adjusts the plate load impedance thus matching the Transmitter to the antenna.

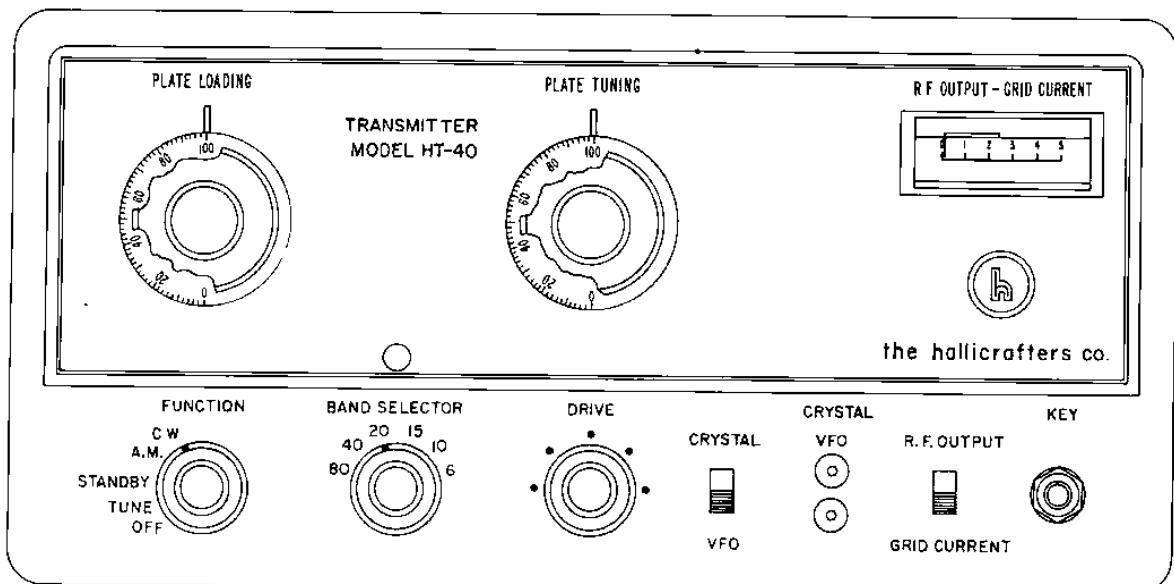

092-01041

Figure 5. Model HT-40 Front Panel Controls

4-7. PLATE TUNING CONTROL

The PLATE TUNING control is a variable capacitor which tunes the plate circuit of the final amplifier (6DQ5) to the desired operating frequency.

4-8. MIKE GAIN CONTROL

The MIKE GAIN control, a 1 megohm potentiometer located on the rear of the chassis controls the audio signal applied to the grid of the audio amplifier tube V3B.

SECTION V OPERATION

5-1. GENERAL

that the transmitter may be operated successfully when only rough tuning adjustments are made. A clean signal from any transmitter requires good operating technique.

5-2. TUNING PROCEDURE FOR CW OPERATION

The following tuning procedure must be performed prior to operating the transmitter in the CW mode.

EQUIPMENT REQUIRED:

1. 50 ohm non-inductive dummy load or a 40 watt light bulb (see fig. 6).
2. Crystal with its fundamental or harmonic frequency corresponding to the desired transmitting frequency or an external VFO.

PROCEDURE

1. Set the controls as indicated:

MIKE GAIN	Maximum counter-clockwise
FUNCTION	OFF
BAND SELECTOR	Desired band
DRIVE	Center of range
CRYSTAL-VFO	CRYSTAL
RF OUTPUT-GRID CURRENT	GRID CURRENT
PLATE LOADING	
80 to 10 meter bands	Near 100
6 meter band	Near 0
PLATE TUNING	
80 to 10 meter bands	Near 100
6 meter band	Near 0

2. Insert crystal of desired frequency into the CRYSTAL-VFO socket.

at this time to allow the operator to tune the transmitter, however, this is not necessary since the jank is a normally closed circuit type when the key plug is removed.

4. Connect the dummy load to the antenna connector on the rear chassis panel and plug the line cord into a 117 volt AC utility outlet.
5. Set FUNCTION control to STANDBY, allow approximately 5 minutes to warm up, then set FUNCTION control to TUNE.
6. Adjust DRIVE control for maximum deflection on the RF OUTPUT-GRID CURRENT meter.
7. Set RF OUTPUT-GRID CURRENT switch to the RF OUTPUT position.
8. Rotate FUNCTION control to CW.

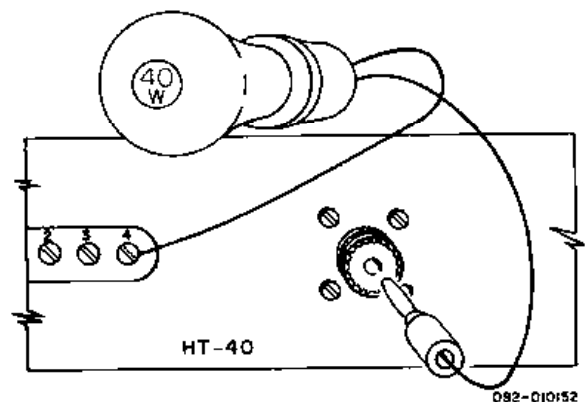

Figure 6. Light Bulb Used as Dummy Load

NOTE

In steps 9, 10 and 11 the final setting of the PLATE LOADING and PLATE TUNING controls will be near 100 on the 80 meter band and progressively lower on the 40 to 6 meter bands. On the 6 meter band two maximum output indications can be obtained. The correct setting will be between 0 and 20.

9. Adjust PLATE TUNING control for maximum output indication on the meter.
10. Adjust PLATE LOADING control for maximum output indication on the meter.
11. Repeat steps 9 and 10 until maximum output is obtained; note the approximate meter reading.
12. Turn Transmitter off with the FUNCTION control, disconnect the dummy load and connect the transmitting antenna.
13. Rotate the FUNCTION control to CW and note output indication. If the antenna impedance is approximately the same as that of the dummy load the meter

proximately zero indication will be noted.

14. If the proper indication is obtained on the meter the HT-40 is ready for CW operation.

5-3. TUNING PROCEDURE FOR AM OPERATION

The procedure for tuning the Transmitter for AM operation is identical to the tuning procedure for CW operation in Paragraph 5-2, step 1 through step 12 except that the CW key need not be plugged in. The following procedure will complete the tuning of the transmitter for AM operation:

1. Connect the microphone to the MIKE connector on the rear of the chassis.
2. Rotate the FUNCTION control to AM; note the meter indication, it should be approximately one fourth the indication noted in step 11 of paragraph 5-2.
3. While talking in a normal voice level two to three inches from the microphone and observing the meter, advance the MIKE control clockwise until a peak indication is observed during "talk" periods.

noted: if antenna line is shorted ap-

patterns if it is desired to use a scope.

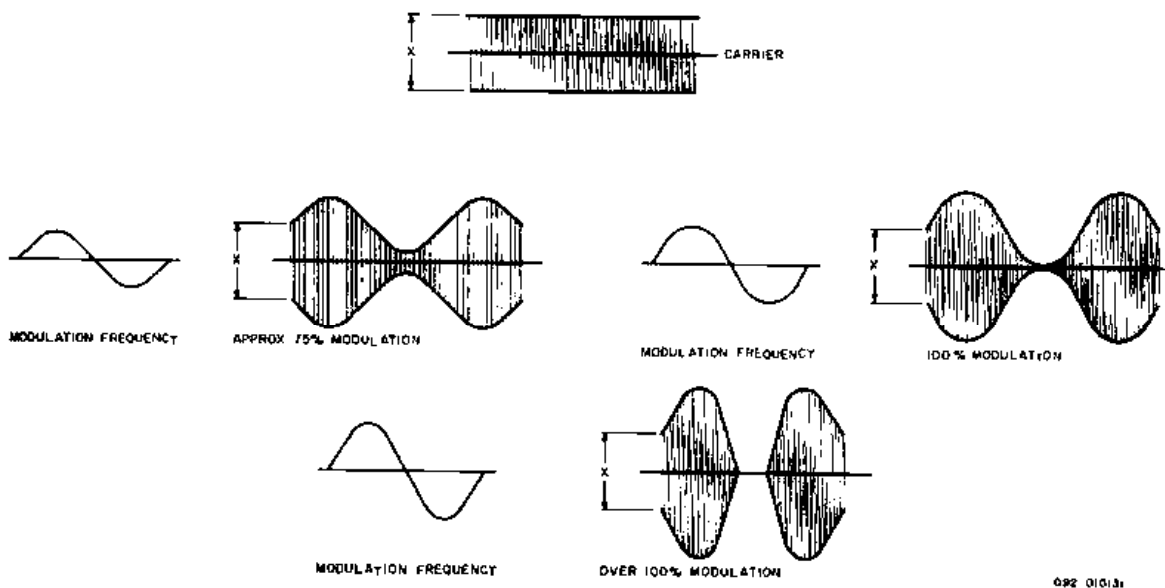

Figure 7. Carrier Modulation Patterns

5-4. SERVICE OR OPERATING QUESTIONS

For any further information regarding operation of the Model HT-40 Transmitter, contact the Hallicrafters dealer. The Hallicrafters Company maintains an extensive system of authorized service centers where any required service will be performed promptly and efficiently at a nominal charge. All Hallicrafters Authorized Service Centers display the sign shown at the right. For the location of the one nearest you, consult your dealer or telephone directory.

Do not make any service shipments to the factory unless instructed to do so by letter. The Hallicrafter Company will not accept the responsibility for unauthorized shipments.

The Hallicrafters Company reserves the privilege of making revisions in current production of equipment and assumes no obligation to incorporate these revisions in earlier models.



92X1401-C

SECTION VI THEORY OF OPERATION

6-1. GENERAL

The HT-40 Transmitter utilizes a built-in oscillator circuit or external VFO for generating the desired fundamental signal that is to be amplified straight through, or operated on a harmonic generator to produce the desired output frequency on each band. Circuits are employed in the Transmitter to permit operation at any desired frequency in the 80, 40, 20, 15, 10, and 6 meter bands on CW (continuous wave) or AM (amplitude modulation). Screen injection or carrier control modulation is employed for phone transmission.

6-2. CRYSTAL OSCILLATOR

The triode section of V1 (6CX8) is used in a modified Pierce Type of crystal oscillator circuit. In this circuit, feedback energy is fed from the plate to the grid by means of a 4700 mmf capacitor in series with the crystal. The grid circuit elements consist of a 47K ohm grid return resistor shunted by a 22 mmf capacitor loading capacity. The plate circuit utilizes a 2.5 MH choke as a common fixed plate load for all frequencies of operation. Coupling from the oscillator plate to buffer grid is accomplished with a 1000 mmf capacitor.

When operating the Transmitter with external VFO, the crystal is removed from the pin jacks and the VFO output terminals are connected to the pin jacks. The high side of the VFO output is connected through the red jack to the grid of V1 (6CX8) and the ground side of the VFO output is connected through the black jack and switch S1 in the VFO position, to ground. When S1 is in the VFO position the 4700 mmf feedback capacitor is disconnected from the circuit.

During CW operation the cathode of this tube is switched to and from ground with the operation of the key.

6-3. BUFFER-MULTIPLIER

The pentode section of V1 (6CX8) is operated as a buffer multiplier. The signals are fed from the oscillator circuit to the grid of the buffer and amplified or multiplied by this stage operating in class C. The buffer plate load consists of a shunt fed 1 MH choke coupled to the grid of the final amplifier tube V2 (6DQ5) by means of a pi network with separate inductances for each band. The network input is tuned with the DRIVE capacitor and the network output is terminated with a 33 mmf capacitor connected to the 6DQ5 grid circuit. Because of the proper selection of coils in each band, it is impossible to tune to a harmonic of the output frequency with the DRIVE capacitor. This reduces the possibility of undesirable signals being fed to the antenna and keeping television interference to a minimum.

6-4. FINAL AMPLIFIER STAGE

The final amplifier stage utilizing a 6DQ5 beam powered pentode tube operates as a "straight through" amplifier on the 80 through 10 meter bands and as a frequency doubler on the 6 meter band. The final amplifier plate load consists of a shunt fed RF choke capacitively coupled to the pi section network. The input of the network is tuned with the PLATE TUNING capacitor, and is terminated with the PLATE LOADING capacitor for matching the plate impedance to the impedance of the antenna. A tapped coil (L10) is used for the 80 through 10 meter bands, the 6 meter band uses a separate coil (L9) connected at right angles to L10

so that a minimum of mutual inductance exists between them. A sensitive meter (M1) is used in this circuit to measure grid current and output power.

6-5. RF OUTPUT-GRID CURRENT METER

The RF OUTPUT-GRID CURRENT meter is a basic 5 mil movement graduated in 5 units (0-5). The meter and its circuitry perform two important functions:

1. With the switch S4 in the GRID CURRENT position the final amplifier grid current can be measured, each division indicates approximately 1 milliampere.
2. With switch S4 in the RF OUTPUT position the output power delivered to the antenna can be measured. Each division on the meter represents approximately 10 watts, therefore if a deflection of three and a half divisions is indicated, 35 watts are being delivered to the antenna ($3.5 \times 10 = 35$).

6-6. SPEECH AMPLIFIER AND MODULATOR

The speech amplifier section of the audio system consists of the two triode sections of V3 (12AX7) and one triode section of V4 (6DE7) RC coupled and operated in cascade to develop an adequate signal input to the modulator (second

adequate signal input to the modulator (second triode section of V4). The modulator has a low plate resistance and acts as a high level cathode follower. The screen impedance of the 8DQ5 (the modulated element) becomes an appreciable portion of the cathode follower impedance. The audio frequency component of the cathode follower is applied in full to the screen of the final amplifier (8DQ5) tube through a .5 mfd capacitor to permit modulation of the screen. An RF filter between the microphone jack and the grid of the MIKE pre-amplifier (V1A) eliminates distortion in the system which could be caused by RF across the microphone jack.

6-7. POWER SUPPLY

The DC voltage to operate the Transmitter is obtained by rectifying the AC voltage across the secondary of the power transformer T1 with a full wave voltage doubler circuit using two silicon diode rectifiers. Adequate filtering of the power supply is accomplished by the voltage doubler circuit, together with the choke and output filter capacitors.

Another secondary winding of the power transformer furnishes filament voltage for all of the tubes in the transmitter.

To prevent television interference from being conducted back through the power cord to the power line an LC filter is connected across the power transformer primary.

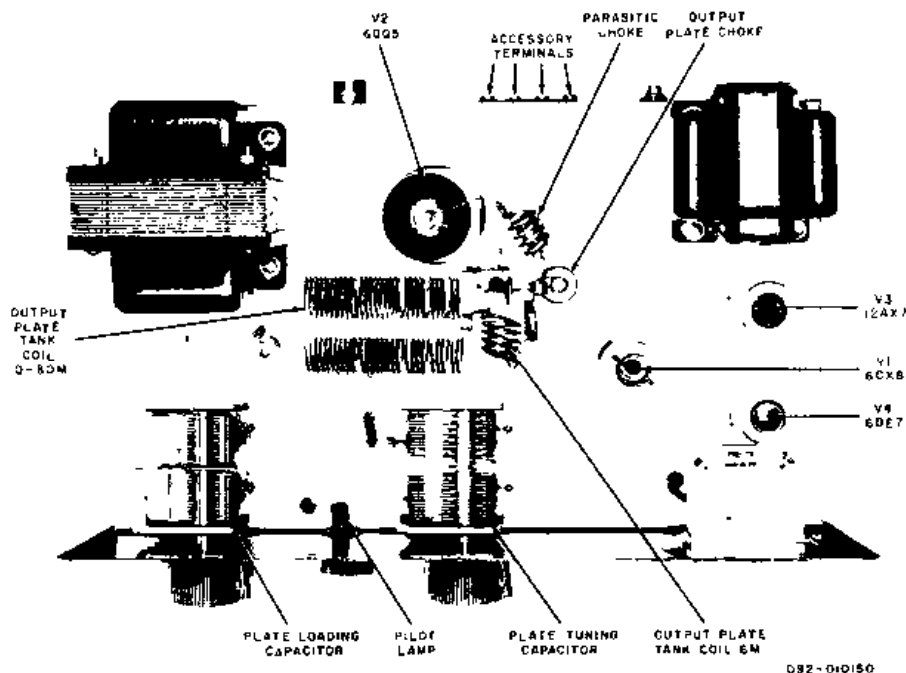

Figure 8. Chassis, Top View

SECTION VII SERVICE DATA

7-1. CHASSIS REMOVAL

Remove the 10 No. 6 threadforming screws from the rear of the cabinet. Slide the chassis, including the front panel, out the front of the cabinet.

7-2. TUBE AND PILOT LIGHT REPLACEMENT

Access to the tubes and pilot light may be obtained by removing the chassis from the cabinet (see para. 7-1). For tube and pilot light location refer to figure 8.

7-3. TROUBLE SHOOTING

In the HT-40 as in all well-designed com-

munications equipment, maintenance and repair problems are generally confined to checking and replacing defective tubes. Malfunctions of this nature are easily isolated and corrected by tube substitution. Should malfunctions other than faulty tubes occur refer to the schematic diagram for proper voltage, resistance, and capacity values.

Table 1 provides suggestions for servicing the HT-40. It is possible that this table is incomplete as there are numerous causes for improper operation of any piece of equipment which can only be determined with elaborate instruments and a complete knowledge of the entire circuit. However, each component of the HT-40 is pretested before it is placed in the unit, thus the table will provide adequate servicing information in most instances.

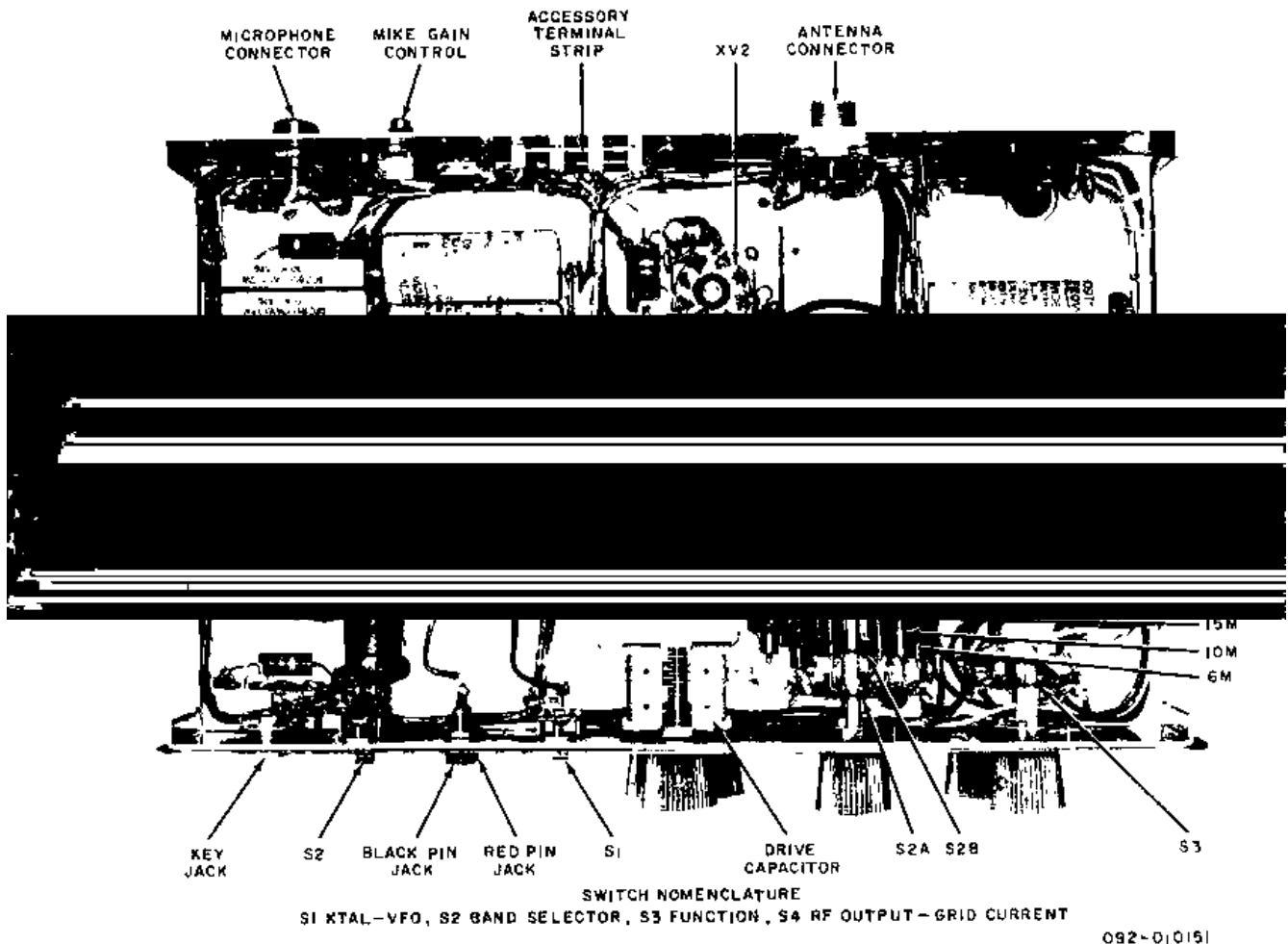

Figure 9. Chassis, Bottom View

Table 1. Trouble Shooting Information

Symptom	Possible Cause
No output on any band (AM or CW)	1. V1 or V2 defective. 2. T1, L16 and/or associated power supply components defective. 3. Shorted antenna.
No AM modulation on any band; CW operation function properly	1. V3 or V4 defective. 2. Microphone and/or associated components in the audio system defective.
No output on any one band.	1. Defective interstage coil for particular band. 2. BAND SELECTOR defective. 3. Oscillator Crystal defective.

SERVICE PARTS LIST

Schematic Symbol	Description	Hallcrafters Part Number	Schematic Symbol	Description	Hallcrafters Part Number	Schematic Symbol	Description	Hallcrafters Part Number
CAPACITORS								
C1	4700 mfd., 500V, 5% Duramica	482-362472	R15, 17, 19	470K ohm	451-252474	J1	Jack, Pin; Black	036-000295
C2	22 mfd., 300V, 5% Duramica	481-152220	R16	1 megohm, Variable, MDKE GAIN	025-001949	J2	Jack, Pin; Red	036-000294
C3, 8, 10, 11, 12, 13, 20, 23, 24, 32	.003 mfd., 500V; Cer. Disc	847-100442	R18	10 megohm	451-252106	J3	Jack, Phase, KEY	036-100602
C4, 5, 6, 30, 31	.001 mfd., 1008V Cer. Disc	047-101101	R20	18K ohm, 2W	451-652183	J4	Connector, Microphone	028-100666
C7	.81 mfd., 500V; Cer. Disc	047-100324	R21	100K ohm, 1W	451-352104	J5	Connector, Coaxial	010-100056
C9	1000 mfd., 500V, 5% Duramica	482-282102	R22	2.2K ohm	451-252222		Socket, Tube, 9 Pin Min (V1, 3, 4)	005-000047
C14, 27, 28, 33, 38, 40, 41, 42, 43	.001 mfd., 500V; Cer. Disc	047-200236	R23	3.3K ohm, 1W	451-352332		Socket, Tube, Octal (V2)	005-000048
C15	6-37 mfd., Variable DRIVE control	048-000499	R24	1K ohm	451-252102		Terminal Board, Accessory (4 contacts)	011-001077
C16, 21	.002 mfd., 300V; Cer. Disc	047-100396	R25	56K ohm	451-252563	TUBES, LAMPS AND RECTIFIERS		
C17	14-140 mfd., Variable, PLATE TUNING Control	048-000495	R26	20 ohm, 7W Wirewound	024-001356	CR1, 2	Diode, Silicon (Voltage Doubler Circuit)	019-002634
C18	.001 mfd., 3KV, Cer. Disc	047-100397	R27, 28	15K ohm, 10W	024-001379	CR3	Diode, Germanium (Meter Circuit)	819-301980
C19	23 mfd., 500V, 5% Duramica	482-152330	R29	1K ohm, 2W	451-652102	V1	6CX8; Oscillator and Haller	090-901418
C22	100 mfd., 15V, Electrolytic	045-000688	R30	100 ohm	451-252101	V2	6DQ5; RF Output	090-901500
C25	22-000 mfd., Variable, PLATE LOADING Control	048-000496	*RESISTORS (cont.)			V3	12AX7; Microphone Pre-Amplifier and 1st Audio Amplifier	090-000038
C26	47 mfd., 2KV, 10% Cer. Disc	047-100459	COILS AND TRANSFORMERS			V4	6DE7; 2nd Audio Amplifier and Modulator	090-901419
C29	100 mfd., 500V; Cer. Disc	047-001182	L1	2.5 MH, 120 MA, RF Choke	053-000587	LMI	Pilot Lamp, Neon	039-000813
C32	.1 mfd., 500V, 10% Molded Paper	496-031104	L2	1 MH, 100 MA, RF Choke	053-000588	MISCELLANEOUS		
C34	.01 mfd., 1500V, Cer. Disc	047-200752	L3	Coil, Interstage P1 Network (80 M)	051-003006		Bass, Tube Shield (V1, 3, 4)	069-001417
C35	100 mfd., 1KV; Cer. Disc	047-001397	L4	Coil, Interstage P1 Network (40 M)	051-003007		Bracket, Tube Mtg (V2) Cabinet	087-000681
C36	.47 mfd., 400V, 10% Molded Paper	499-821474	L5	Coil, Interstage P1 Network (20 M)	051-003008		Cable, Coaxial; 8 inches	150-000398
C37	.003 mfd., 1KV, 20% Cer. Disc	047-100523	L6	Coil, Interstage P1 Network (15 M)	051-003009		Cable, Coaxial; RG-58/U; 8 inches	087-105313
C44, 45, 46, 47	.90 mfd., 350V Electrolytic	046-000723	L7	Coil, Interstage P1 Network (10 M)	051-003010		Fork, Plastic	087-100000
*RESISTORS								
R1, 2	47K ohm	451-252473	L8	Coil, Interstage P1 Network (6 M)	051-003011		Insulator, Stand Off (L9 and L10 mtg.)	008-000149
R3, 5, 11	22K thru 2W	451-652223	L9	Coil, Output Tank (5 M)	051-003052		Knob, FUNCTION and BAND SELECTOR	015-201258
R4	100K thru	451-252104	L10	Coil, Output Tank (80 thru 18 M)	051-003022		Knob, DRIVE	815-301258
R5	470 ohm	451-252471	L11	Parasitic Choke Assembly	053-000605		Knob, PLATE LOADING and PLATE TUNING	815-001566
R6, 13	2.5K ohm, 7W	824-001337	L12	33 MH, 200 MA; RP Choke	053-000599		Line Cord	087-100076
R7	1 megohm	451-252105	L13	.425 MH; Plate Output Choke	053-000908		Lock, Line Cord	076-200397
R8	38K ohm, 1W	451-352393	L14, 15	3.8 OH; Line Choke	053-000807		Meter, RF OUTPUT - GRID CURRENT	082-000493
R10, 12	4.7K ohm	451-252472	L16	5 H; Filter Choke	026-000448		Panel, Front	048-001120
R14	2.2 megohm	451-252225	T1	Transformer, Power	052-000852		Shield, Electrical	089-001402
SWITCHES								
S1	Switch, SPDT; XTAL-VFO	060-202607	JACKS, SOCKETS AND CONNECTORS				Spacer (C17 and C25 mtg.)	062-100430
S2A, B, C	Switch, Rohmy; BAND SELECTOR	090-002265					Washer, Flat Fiber (Stand Off Insulator Mtg.)	073-003891
S3	Switch, Rohmy; FUNCTION	090-002268						004-200522
S4	Switch, DPDT; RF OUTPUT - GRID CURRENT	060-002266						

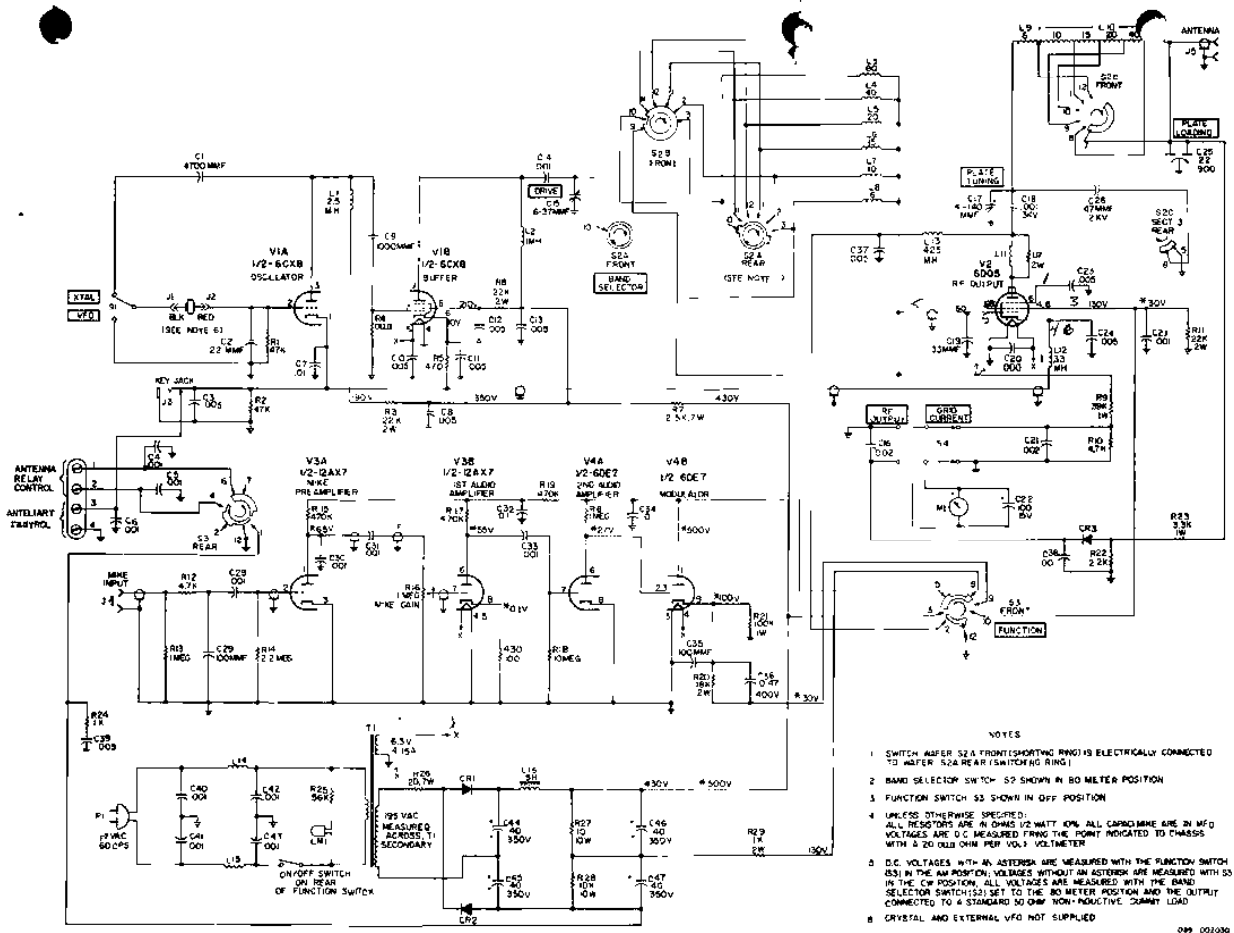

- NOTES
1. SWITCH WAFER S2A FRONT (SHORTING RING) IS ELECTRICALLY CONNECTED TO WAFER S2A REAR (SWITCHING RING)
 2. BAND SELECTOR SWITCH - S2 SHOWN IN 80 METER POSITION
 3. FUNCTION SWITCH S3 SHOWN IN OFF POSITION
 4. UNLESS OTHERWISE SPECIFIED: ALL RESISTORS ARE 1/2 WATT 10% ALL CAPACITORS ARE IN MFD VOLTAGES ARE D.C. MEASURED FROM THE POINT INDICATED TO CHASSIS WITH A 20 OHM OHM PER VOLTS VOLTMETER
 5. D.C. VOLTAGES WITH AN ASTERISK ARE MEASURED WITH THE FUNCTION SWITCH (S3) IN THE AM POSITION; VOLTAGES WITHOUT AN ASTERISK ARE MEASURED WITH S3 IN THE CW POSITION; ALL VOLTAGES ARE MEASURED WITH THE BAND SELECTOR SWITCH (S2) SET TO THE 80 METER POSITION AND THE OUTPUT CONNECTED TO A STANDARD 50 OHM NON-INDUCTIVE LOAD
 6. CRYSTAL AND EXTERNAL VFO NOT SUPPLIED

Figure 10. Model HT-40 Schematic Diagram