



OPERATING and SERVICE
INSTRUCTIONS



the hallicrafters co.

MANUFACTURERS OF ELECTRONIC EQUIPMENT, CHICAGO 24, U. S. A.

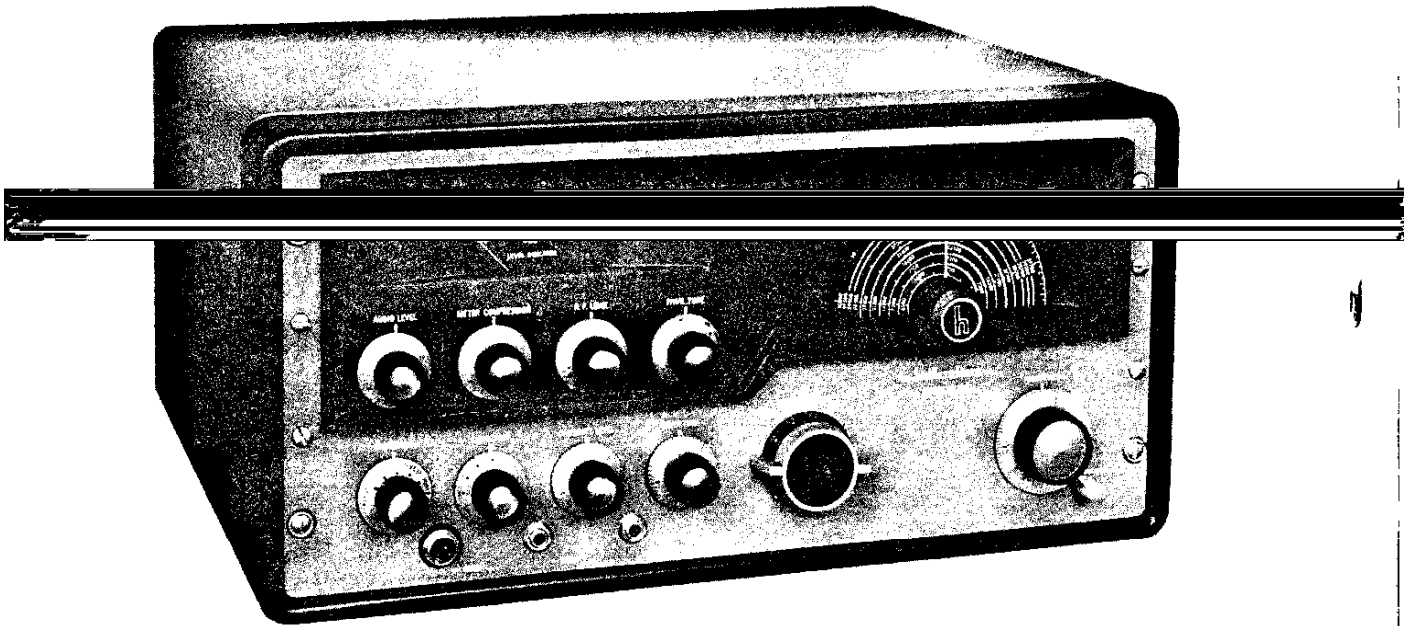

092-103923

Figure 1. Hallicrafters Model HT-32A Transmitter/Exciter

SECTION I GENERAL

1-1. DESCRIPTION.

The Hallicrafters Model HT-32A Transmitter/Exciter is the ultimate in design of self-contained transmitting equipment. This twenty-tube precision built

with suppressed carrier), DSB, and CW transmission in the 80, 40, 20, 15, and 10 meter bands. This unit can represent the complete transmitting complement of any amateur station. The only requirements for immediate "on the air" operation are a 50-ohm terminated antenna system, key or microphone, and AC power source.

1-2. SCOPE OF OPERATION.

This unit may be utilized as a complete self-contained transmitter, or as an exciter for a linear power amplifier such as the Hallicrafter Model HT-33A. If other linear amplifiers are employed, they should be capable of supplying a 50-ohm termination to the driver output to utilize the full capabilities of the HT-32A Transmitter/Exciter. Maximum power output ratings of the HT-32A Transmitter/Exciter are:

SSB, 70-100 watts P. E. P. (peak envelope power); CW 70-100 watts; and DSB 17-25 watts (carrier power).

Prominent features of the HT-32A Transmitter/Exciter are:

- New high frequency crystal sideband filter - rejection 50 db. or more.
- Bridged-tee sideband modulator.

- C. T. O. direct reading in kilocycles to less than 300 cycles from reference point.
- 144 watts plate input (P. E. P. two-tone).
- Fiveband output (80, 40, 20, 15, 10 meters).
- Unwanted sideband down 50 db. or more.
- Carrier suppression down 50 db. or more.

1-3. T.V.I. (Television Interference) SUPPRESSION.

The HT-32A Transmitter/Exciter has been designed and constructed to suppress spurious radiations that may cause television interference. The TVI problem was given full consideration in the design of every circuit as well as in the selection and layout of parts. Adequate filtering has been provided for control circuits and AC power lines. Components were specifically selected to avoid undesired resonances and arranged to prevent parasitic oscillation.

Another important T. V. I. proofing feature is employed in the output coupling circuit of the final amplifier. The tuned output circuit is a pi network that has inherently excellent harmonic suppression ability. The unique design of this network is such that the conventional loading control is unnecessary and only the final tank tuning need be adjusted. The pi network is connected to a coaxial connector and permits the use of any antenna system having a transmission line impedance of 50 ohms. In addition to these factory installed precautions, a commercial 50-ohm low pass TVI filter, which connects between the antenna and the transmitter/exciter output, can be used.

The Model HT-32A Transmitter/Exciter, as received from the factory, has had every advantage of Hallicrafters advanced engineering to minimize television interference. There are, however, some types of TVI that cannot be prevented within the transmitter itself. For example, when a television receiver is located in the immediate vicinity of the transmitter/exciter it is entirely possible that a fundamental signal will reach the input grid of the receiver in sufficient strength to cause a slight amount of interference. In

such cases, it will be necessary to install a filter or trap at the television receiver to attenuate the transmitter's fundamental signal. If the interfering signal does not enter the television receiver through the antenna, special shielding or filters on the TV receiver may be necessary. For a more complete discussion of measures that may be used to handle these special television interference problems, refer to the ARRL HANDBOOK.

SECTION II INSTALLATION

2-1. UNPACKING.

After unpacking the HT-32A Transmitter/Exciter, examine it closely for any possible damage which may have occurred during transit. Should any sign of dam-

age be observed, contact the manufacturer immediately. Connections for keying are also provided on the Control Outlet receptacle on the rear panel. See paragraph 2-5-2-2. Wire the plug so that the key base is connected to the sleeve of the plug which is also at chassis ground.

shipping labels and tags for any special instructions before removing or destroying them.

2-2. LOCATION.

Although the Model HT-32A Transmitter/Exciter is provided with a built-in power driven fan for cooling purposes, avoid excessively warm locations such as those near radiators and heating vents. The unit should be placed in a location that provides adequate space around it, permitting free circulation of air through the cabinet openings.

2-3. POWER SOURCE.

The HT-32A Transmitter/Exciter is designed to operate on 105 to 125 volt, 50-60 cycle AC current; power consumption is 375 watts.

IMPORTANT: If in doubt about your power source, contact your local power company prior to inserting the power cord into an AC power outlet. Plugging the power cord into the wrong power source can cause

This standard two-conductor phone jack permits voice controlled headphone reception in the VOX mode of operation. The MONITOR jack accepts a general purpose two-conductor phone plug. Inserting the plug of a headset into this jack will automatically cut off the receiver speaker when it is connected as instructed in paragraph 2-5-2-4.

2-5. REAR CHASSIS CONNECTIONS (See Fig. 2).

Sockets are provided on the rear of the HT-32A Transmitter/Exciter for the following purposes:

2-5-1. RF OUTPUT.

This is a coaxial connector which connects the HT-32A Transmitter/Exciter to the antenna system or a linear amplifier. The connecting cable (52 ohm coax.) should be fitted with an Amphenol type 83-1SP connector or its equivalent. The selection of the type of antenna and coupling will depend upon the frequencies used and the purpose of operation. Refer to the ARRL ANTENNA HANDBOOK for detailed information concerning trans-

costly repairs.

2-4. FRONT PANEL CONNECTIONS (See Fig. 1).

Receptacles are provided on the front panel of the HT-32A Transmitter/Exciter for the following purposes:

2-4-1. MIKE RECEPTACLE.

The Model HT-32A Transmitter/Exciter is designed to operate with a high impedance communications type microphone. The microphone cable should be fitted with an Amphenol type 80-MC2M connector and should be wired as shown in the schematic diagram, Figure 14. If the microphone used does not have a push-to-talk switch, the switch circuitry may be disregarded and the microphone connected between pin 1 and the shield (connector body).

2-4-2. KEY JACK.

This standard two-conductor phone jack is provided on the front panel for hand key or "bug" operation. The KEY jack accepts a general purpose standard two-con-

2-5-2. CONTROL OUTLET.

An eleven pin socket is provided at the rear of the chassis to connect the HT-32A Transmitter/Exciter into your control system. The mating connector for this socket is an Amphenol 86-PM11. The instructions which follow may be modified to suit your particular needs.

2-5-2-1. ACCESSORY RELAY CONTACTS (Pins 6 and 7).

Two extra relay contacts working against chassis ground (Relay arm grounded, contacts connected to pins 6 and 7) are available for applications where a closed circuit to chassis is required in either the transmit or receive condition. When transmitting pin 6 is at chassis ground and pin 7 is open circuit. During standby or receive periods, pin 6 is open circuit and pin 7 is at chassis ground. See Figure 3 for a typical application.

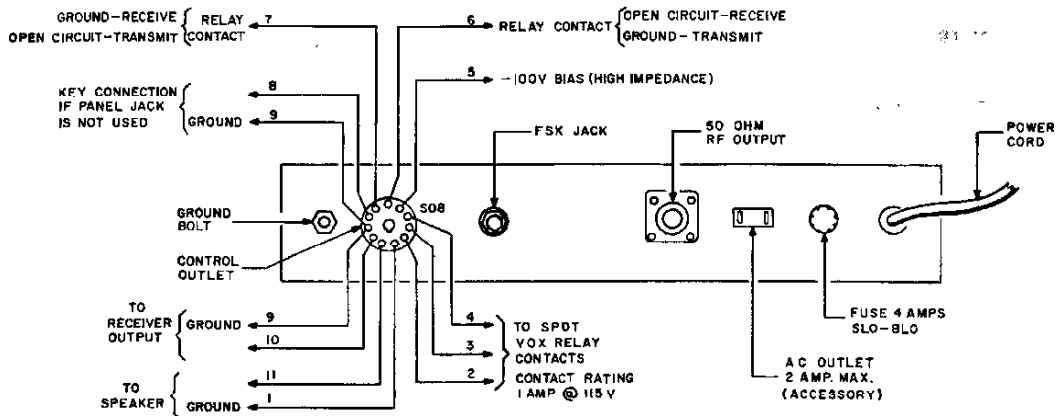

Figure 2. Rear Chassis Connections

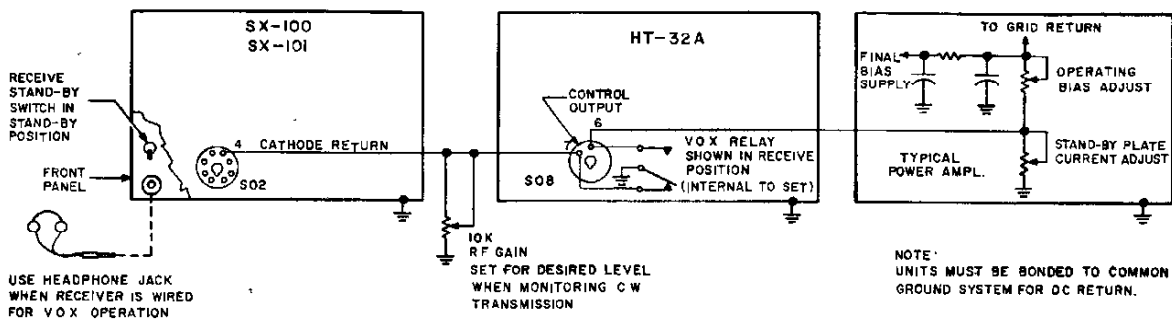

Figure 3. Application For Accessory Relay Contacts

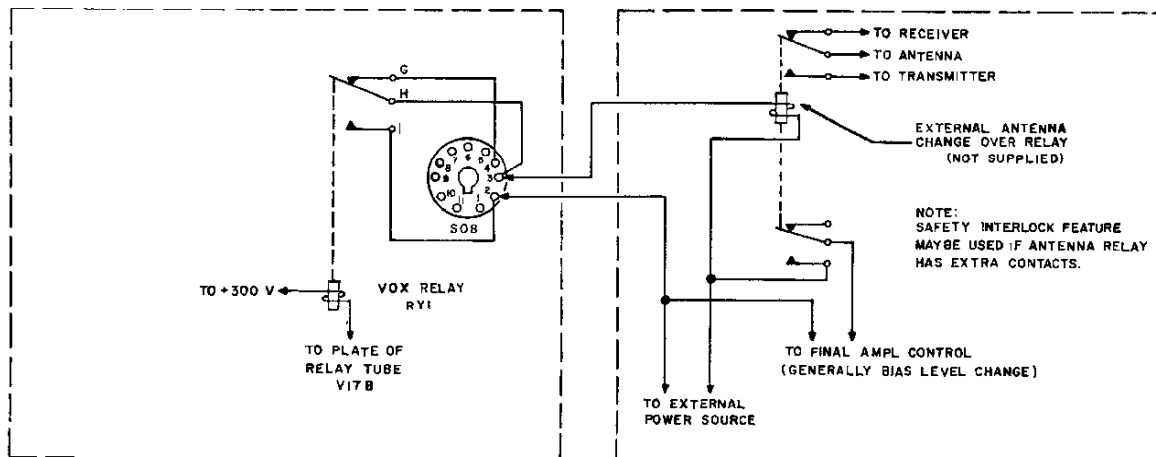

Figure 4. Control Outlet Relay Connections

095-305793

2-5-2-2. KEY (Pins 8 and 9).

For CW operation, the hand key or "bug" is connected to pins 8 and 9 of the control outlet. Pin 9 is internally grounded in the unit. When the key is up, cutoff bias is maintained at the second and third mixer stage. Closing the key removes the cutoff bias providing signal excitation to the succeeding RF amplifier stages. A key jack is also provided at the front panel for those who prefer a panel connection for the key.

2-5-2-3. ANTENNA RELAY (Pins 2, 3 and 4).

An external antenna change-over relay may be employed by utilizing pins 2, 3, and 4 on the control outlet. These pins are connected internally to insulated contacts on the VOX RELAY of the HT-32A Transmitter/Exciter. Figure 4 illustrates typical connections of an external change-over relay to the control outlet. During periods of transmission the VOX relay connects pins 2 and 3 enabling the external power source to activate the external antenna change-over relay. For external applications where an open circuit is required when transmitting, pins 3 and 4 may be used. The voltage required of the external power source is dependent upon the type change-over relay used. A coaxial type relay for 50-ohm transmission line impedance is recommended. Where pins 2, 3, and 4 are used to switch external equipment loads, the load current should be limited to one ampere.

2-5-2-4. RECEIVER AUDIO (Pins 9 and 10) AND SPEAKER (Pins 1 and 11).

Connect the audio output of the station's receiver directly to pins 9 and 10 of the control outlet. (Pin 9 is ground or chassis side.) Connect a 2 watt resistor across the receiver audio output to maintain a load at all times. The receiver speaker is connected directly to pins 1 and 11. (Pin 1 is ground side.) Connecting the receiver and speaker in this manner prevents the actuating of the HT-32A transmitter/exciter VOX circuit by incoming audio signals from the receiver and also disconnects the receiver output to the speaker when the HT-32A Transmitter/Exciter is on the air. Use an 18-ohm 2 watt resistor for 3 to 8 ohm voice coil impedances or 1500 ohm 2 watt resistor for 500-600 ohm outputs.

2-5-2-5. BIAS (Pins 5 and 9).

A high impedance bias source is available at pin 5 with pin 9 used as the return or ground connection. The bias is fixed at approximately -100V regardless of the mode of operation of the transmitter. An external relay may be used with the fixed bias provided at pin 5 to obtain the desired application. Note that the bias source is high impedance and not intended as a "hard"

bias source for fixed bias applications in power amplifiers.

2-5-3. FSK JACK.

This is a standard 3-circuit jack that brings out the keying circuit required for frequency shift keying used in teletype transmission. For a more detailed explanation refer to NOTES on page 23. The FSK jack accepts the standard size general purpose three-conductor phone plug.

2-5-4. ACCESSORY POWER OUTLET.

A standard AC receptacle is provided at the rear apron as a convenient source of 117V AC power for the antenna relay or similar light duty loads. Do not use this outlet for heavy loads such as a power amplifier.

2-6. PHONE PATCH INPUT.

While this connector is not located on the rear apron, its connecting cable will be fed through one of the rear cabinet vents. The receptacle is located on the side-band generator unit in the upper right hand corner of the deck near the microphone input connector. The receptacle is a standard "phono" type of jack used on record players for shielded audio cables. The input impedance is 500-600 ohms, and the signal level required for maximum SSB power or 100% AM modulation is a function of the AUDIO LEVEL control setting, and runs approximately 4 millivolts at the full clockwise position. At reduced sensitivity settings of the AUDIO LEVEL control, demanded by the output of the operator's microphone, the phone patch input level for maximum transmitter output will be proportionately higher.

2-7. ADDITIONAL COUPLING FOR CALIBRATING SIGNAL.

Most installations will not require additional measures to couple the receiver to the transmitter for an adequate calibrating signal level. However, there are situations where more coupling may be desired. A phone tip jack has been provided at the top of the shield over the final amplifier tubes to cope with such situations. With this configuration the signal level is adequate so that the capacity coupling between the jack, final tank capacitor, and tube caps will provide more than enough coupling if a wire lead with a phone tip soldered to it is used to couple the receiver to the transmitter. The phone tip is merely a convenient way of anchoring the coupling lead securely to prevent its accidentally coming into contact with the amplifier components inside the shield compartment. The receiver end of the coupling lead may be connected to the receiver antenna terminal or may be brought into close proximity of the antenna terminal as determined by trial.

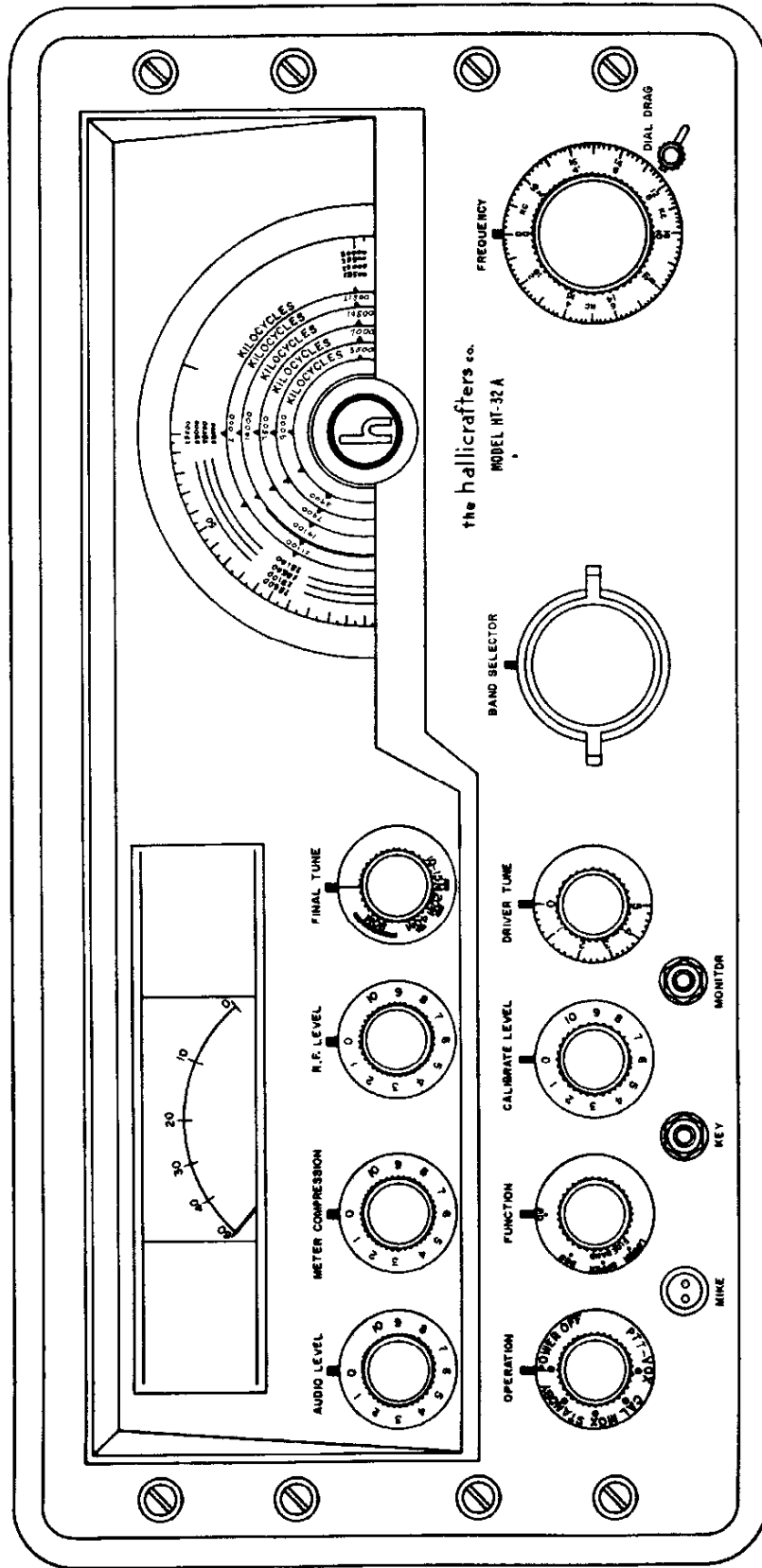

092-303654

Figure 5. Front Panel

SECTION III

FUNCTION OF OPERATING CONTROLS

3-1. FUNCTION.

The FUNCTION control is a four position rotary switch which selects CW, DSB, UPPER or LOWER SIDEBAND type of transmission as desired by the operator. An analysis of the FUNCTION switch operation is given in paragraphs 4-4, 4-5, and 4-6.

3-2. OPERATION.

This control is a five position rotary switch which turns the power to the transmitter on or off, places the transmitter in calibrate operation or selects the mode of operation (VOX or MOX). The "CALIBRATE" position is used in conjunction with the CALIBRATE LEVEL control. (See paragraph 3-11).

The "MOX" position energizes the transmitter control relay to the transmit position. This position of the OPERATION switch is used when manual control of transmission is desired. Return the switch to the "STANDBY" position during receiving periods.

In the "CALIBRATE" position, the HT-32A Transmitter/Exciter control relay (VOX RELAY) is de-energized, permitting normal receiving operation with an antenna change-over relay (if used) in the receiver position. With the receiver in operation the transmitter signal can now be monitored and the signal level in the receiver controlled with the CALIBRATE LEVEL control. See paragraph 3-11.

In the "PTT-VOX" position, the transmitter control relay may be operated by voice energy from the microphone. The relay tube is biased to cut-off and will not energize the VOX RELAY until signal excitation is received from the audio amplifier and vox amplifier stages. When push-to-talk operation is desired, turn the VOX sensitivity control fully counterclockwise and then control the transmission with the microphone switch.

3-3. DRIVER TUNING.

This control is a variable capacitor in the VFO mixer plate, and driver plate circuits, and will resonate the circuits to any frequency in the 30, 40, 20, 15 and 10 meter bands.

3-4. BAND SELECTOR.

The BAND SELECTOR control is a five position rotary switch which selects the proper combination of tuned circuits and stages for the desired frequency

3-5. FINAL TUNING.

This control is a variable capacitor in the final am-

plifier tank circuit and will resonate the circuit to the operating frequency of the selected band. The dial calibrations permit presetting the control roughly during tune up.

3-6. FREQUENCY.

The FREQUENCY control is a variable capacitor which sets the VFO frequency. The VFO covers the frequency range 5,000 kilocycles to 5,500 kilocycles. With mixing circuits, the VFO will set the HT-32A Transmitter/Exciter to the desired operation frequency as indicated on the dial in any of the five bands. Each minor marker on the skirt of the FREQUENCY control is equivalent to approximately 200 cycles on all bands.

3-7. DIAL DRAG.

This is a mechanical brake which can be adjusted either to lock or apply drag to the FREQUENCY control to avoid accidental rotation of the control during operation.

3-8. AUDIO LEVEL.

This control is a potentiometer connected in the grid circuit of the third audio amplifier stage and adjusts the amount of audio drive to the "bridged-T" balanced modulator. It has sufficient range to permit adjustment for any high level crystal microphone or low level dynamic microphone normally used for voice communications.

3-9. RF LEVEL.

The RF LEVEL control is a potentiometer in the grid bias circuit of the 9 MC amplifier tube to adjust the gain of the 9 MC amplifier. On DSB and CW, the amount of carrier in the output signal is determined by the setting of the RF LEVEL control.

3-10. METER COMPRESSION.

This is a meter sensitivity control which permits the operator to set the meter at maximum deflection (0dB) for desired output level (between approximately 1/4 power and full power) when establishing proper drive levels in the HT-32A Transmitter/Exciter. (See LEVEL INDICATOR METER, paragraph 3-12).

3-11. CALIBRATE LEVEL.

The CALIBRATE LEVEL control provides a low level adjustment of the transmitter output for SSB, DSB, or CW operation when the OPERATION control is set at CALIBRATE. The CALIBRATE LEVEL control is

beat" frequency setting. On SSB a sideband signal is obtained when talking into microphone to "talk onto frequency". If the zero beat method is preferred by the sideband operator, the FUNCTION control is switched

to DSB to obtain a carrier for calibration purposes then switched back to the desired sideband before going on the air. Note that on DSB or CW the preset RF LEVEL setting is not to be disturbed when calibrating.

3-12. LEVEL INDICATOR METER.

The LEVEL INDICATOR METER indicates the output of the HT-32A Transmitter/Exciter in DB below "0" DB reference, enabling the adjustment of the HT-32A Transmitter/Exciter for correct output (drive level required for a linear amplifier or approximate rated output for "barefoot" operation). Tuning of the transmitter has been simplified by the design of the front panel meter circuit. The meter scale is compressed to enable low-level signals to produce a usable indication, yet strong signals do not drive the meter pointer off scale. This feature gives the meter a wide usable dynamic range which is not possible to obtain with a linear scale. The desired amount of compression may be obtained by adjusting the METER COM-

PRESSION control on the front panel. The output reading on the LEVEL INDICATOR METER can be shifted to read full scale ("0" DB) down to approximately 1/4 of full power and any level below this reference can easily be read on the meter. A log of METER COMPRESSION control settings, for normal output into loads of controlled and reproducible characteristics, will aid in re-establishing proper drive levels and determining the proper operation of the unit. The log should be recorded at various frequencies and modes of operation.

To monitor carrier suppression for SSB operation, set the METER COMPRESSION control to read zero-DB reference on the meter at the maximum sideband output (single tone), and read carrier level directly when the audio excitation is removed. Note that the MOX mode of operation must be used for this test, since on VOX operation the transmitter is disabled between voice controlled transmissions by the operation of the VOX relay.

SECTION IV TUNING PROCEDURE

4-1. GENERAL.

The tuning procedure for the Model HT-32A Transmitter/Exciter has been simplified by design as much as possible to permit rapid adjustment by the operator. This does not mean, however, that a transmitter, commercial or home-built, may be operated successfully when only roughly adjusted. A clean signal from any transmitter requires good operator technique.

ly adjusted linear amplifier. A 50-ohm non-reactive load of at least 100 watts dissipation capabilities is required to handle the full power output.

4-3. INITIAL CONTROL SETTINGS.

Set the front panel controls to their starting positions as outlined below.

60DB or more below fundamental output when the transmitter is correctly tuned up.

1. On the 15-meter band the undesired signal will appear when the DRIVER TUNE control is set outside its normal tuning range, approximately 0 to 1 division on the dial. Note that its level cannot be increased on AM or CW with the RF LEVEL control or driven by speech input on SSB, hence may be identified in this manner.
2. On the 10-meter band the undesired signal will appear when the DRIVER TUNE control is set outside its normal tuning range. For example, when tuning the 29 MC to 29.5 MC segment of the 10-meter band, the DRIVER TUNE control will normally tune up around 4 on the dial while the unwanted signal tunes up at around 2 divisions on the dial. Here again it is identified by the fact that its level cannot be increased on AM or CW with the RF LEVEL control or driven

DRIVER TUNING CENTER OF ROTATION
FINAL TUNING DESIRED BAND SEGMENT
BAND SELECTOR DESIRED BAND
FREQUENCY DESIRED FREQUENCY

4-4. CW TUNING.

The tuning procedure for CW operation will be presented first since AM (DSB) and SSB tuning procedures are modifications of that required for CW operation.

The tuning procedure for CW operation is as follows:

1. Set the OPERATION switch at MOX; FUNCTION switch at DSB.
2. Tune the driver and final amplifier stages with the DRIVER TUNE and FINAL TUNE controls for maximum meter deflection. Advance the RF

Connect a 50-ohm non-reactive load to the R. F. OUTPUT connector on the HT-32A Transmitter/Exciter. This impedance may be an antenna or a proper-

TUNE FOR MAXIMUM OUTPUT.

3. Set FUNCTION switch at CW and close key.

4. Advance the RF LEVEL control slowly while observing the output meter. When feeding a dummy or an antenna load, set the control at a point where further rotation does not cause an appreciable increase in the meter reading. This is saturation output; operate slightly below this level for CW. When driving a final amplifier stage with the HT-32A Transmitter/Exciter, advance the RF LEVEL control until required excitation is obtained for the amplifier. In either case, do not operate beyond the saturation level.
5. A convenient reference for this operating level may be obtained by setting the METER COMPRESSION control so that the output meter reads zero DB.
6. Recheck the driver and final tuning by reducing the carrier level by about 5 or 10 DB on the output meter with the RF LEVEL control and touching up the DRIVER TUNE and FINAL TUNE controls for maximum output. Reset the RF LEVEL control for maximum output just below the saturation point, as outlined above.
7. Open the key. The output should drop to zero.
8. When the transmitter and receiver share the same antenna (via an antenna relay), manual CW operation is accomplished by switching between "MOX" (to transmit) and "STANDBY" (to receive). Note that manual operation will not be possible unless the CW DELAY control (knurled sleeve shaft of R49) is turned fully clockwise. See Figure 9.

shaft) counterclockwise until the VOX relay de-energizes (as in "receive" operation). With this accomplished, any time the key is closed, the VOX relay will energize, and immediate transmission will begin, starting from the first dot. Note that this setting of the CW DELAY control (sleeve shaft) affords the longest delay between the time transmission ends and the receiver is reactivated. For shorter delays, turn the CW DELAY control (sleeve shaft) further counterclockwise. To restore normal CW operation on "MOX", return the CW DELAY control (sleeve shaft) to its maximum clockwise position.

Note that the CW DELAY (sleeve shaft) control adjustment need not be changed when switching to other manually operated modes of operation, such as DSB or SSB; but, if normal manual CW operation is desired, the CW DELAY control (sleeve shaft) must be set at its maximum clockwise position.

Refer to the use of the "CAL" position of the OPERATION switch and the CALIBRATE LEV-

frequency. See paragraph 3-11.

4-5. SSB TUNING.

The tuning procedure for SSB operation is as follows:

1. Set the OPERATION switch at MOX; FUNCTION switch at DSB (Audio level zero).
2. Tune the driver and final amplifier stages as described for CW tune up.
3. Set the FUNCTION switch to UPPER or LOWER sideband as desired. If the output meter was referenced at zero DB for maximum output with the COMPRESSION control, the meter will now indicate the carrier suppression directly in DB below maximum output.
4. Set the OPERATION switch at MOX (manual operation).
5. While monitoring the transmitter output, proceed with SSB transmission, setting the AUDIO LEVEL control for the required audio gain which does not produce peak flattening or overload distortion of the output signal. Note that the output meter damping factor prevents the meter from indicating 0DB reference on voice peaks. The meter will swing roughly 2/3 scale with voice excitation.
6. If manual operation is desired on SSB, switch the OPERATION control between MOX and STANDBY. For voice control operation, with the receiver and transmitter interconnected, set the OPERATION control at PTT-VOX. To "zero-in" on frequency, see paragraph 3-11 regarding the calibration procedure. For infor-

4-6. AM (DSB) TUNING.

The tuning procedure for AM operation is as follows:

1. Set the OPERATION switch at MOX; FUNCTION switch at DSB (Audio level zero).
2. Tune the driver and final amplifier stages as described for CW tune up.
3. When feeding a dummy or antenna load, advance the RF LEVEL control to the saturated output level and reference 0 DB on the output meter with the METER COMPRESSION control, as described for CW tune up. When driving a linear power amplifier with the HT-32A Transmitter/Exciter, advance the RF LEVEL control until maximum linear power output is obtained from the final amplifier stage before setting the reference level on the output meter.
4. With the RF LEVEL control, reduce the carrier level 6 DB, as read on the output meter. This sets the maximum carrier level that the linear amplifiers in the HT-32A Transmitter/Exciter, or following linear power amplifier, can handle

carrier reference level can be established more precisely if an oscilloscope and audio oscillator are used to set up and monitor the output signal. Note that if the carrier level is set too high, peak amplitudes are flattened before 100% modulation occurs. If the carrier level is set too low, the maximum power output capabilities are not attained at 100% modulation.

5. While monitoring the transmitter output, proceed with AM transmission, setting the AUDIO LEVEL control for the required audio gain which does not produce peak flattening, or over modulation distortion of the output signal. Note that the output meter damping factor permits a rough operational check on over-modulation. The output meter will drop about 1 to 2 DB in level when the percentage of modulation with voice excitation runs close to 100%.

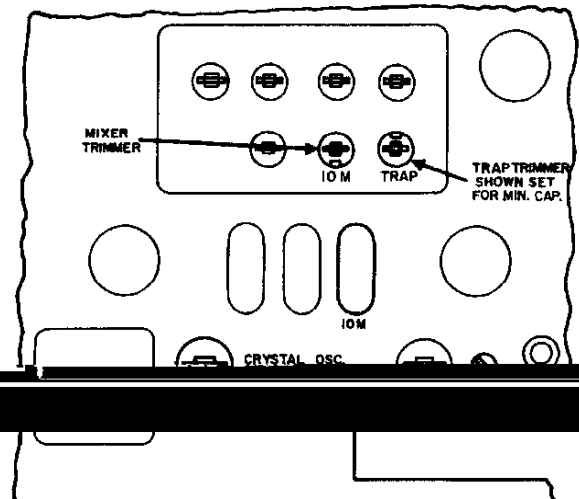

STANDBY. For voice control operation with the receiver and transmitter interconnected, set the OPERATION control at PTT-VOX.

4-7. SEGMENT ALIGNMENT FOR 10M BAND.

The HT-32A Transmitter/Exciter is set up at the factory to provide transmission in the 28.5 to 29.0 MC segment of the 10M band.

The other 0.5 MC segments of the 10M band are set up as follows: (Refer to Figure 6 for locations of the various adjustments referred to in the following procedure.)

1. Tune up on CW and determine the saturation level settings of the RF LEVEL control. Record this setting for future reference in step 5.
2. Remove the 32.5 MC crystal and insert desired crystal.*

BAND	NOMINAL FREQ.	OUTPUT FREQ.	PART NUMBER
10M	*32.0 MC	28.0-28.5 MC	019-201963
10M	32.5 MC	28.5-29.0 MC	019-201964
10M	*33.0 MC	29.0-29.5 MC	019-201965
10M	*33.5 MC	29.5-30.0 MC	019-201966

supplied with the transmitter.

3. Connect electronic voltmeter or similar high impedance DC voltmeter (0-10V) to crystal oscillator test point, and adjust crystal oscillator trimmer for approximately half of the volts obtained at the maximum voltage setting of the trimmer. Set the trimmer on the gentle slope side of resonance.
4. Set TRAP TRIMMER for minimum capacity and adjust 10M mixer trimmer for maximum output. Increase RF LEVEL control setting, if necessary, to pick up an output meter reading as the mixer is tuned to resonance. Back off the RF LEVEL as resonance is obtained with mixer trimmer and DRIVER TUNE control.

Figure 6. 10 Meter Band Adjustments

5. Touch up FINAL TUNE control, then adjust crystal oscillator trimmer and RF LEVEL control until the saturation output again occurs at the RF LEVEL setting, originally obtained for the previous crystal used. See step 1.
6. Trap adjustment - This adjustment is optional as far as spurious output in the 10M band is concerned, since its level is less than 60 DB below fundamental only when the transmitter is mistuned. To locate the spurious signal, turn the RF LEVEL control to zero or switch to the upper or lower sideband position of the operation switch, and tune the DRIVER TUNE and FINAL TUNE for maximum output. Adjust the 10M trap trimmer for minimum output meter reading.

Returning for the desired frequency and peaking the trimmer, since the trap adjustment will affect the original mixer setting slightly.

4-8. USE OF VOX AND DELAY CONTROLS.

The VOX and DELAY controls are located on the top of the HT-32A Transmitter/Exciter chassis, as illustrated in Figure 7. Both controls are utilized in conjunction with VOX operation and are adjusted to provide control of the transmitter and station receiver.

1. The VOX control is an audio sensitivity control which determines the audio level that will trip (energize) the VOX RELAY, and place the HT-32A Transmitter/Exciter "on the air". This control should be adjusted with the micro-

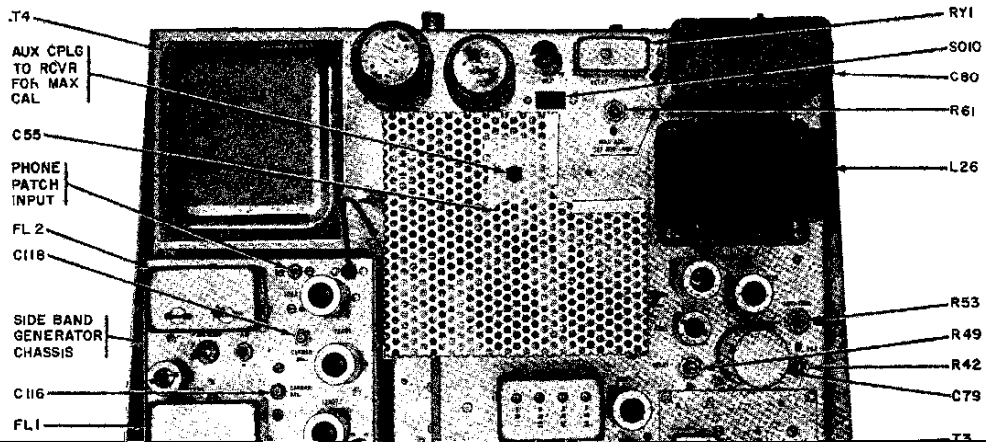

092-103821B

Figure 7. Top Chassis View

phone at the normal speaking distance from the microphone above that which will trip the VOX RELAY. Excessive sensitivity will have the undesirable result of background noise "tripping" the VOX RELAY and placing the HT-32A Transmitter/Exciter on the air. Note that the

mitter/Exciter chassis (Figure 7) and is used in conjunction with the speaker for VOX operation (paragraph 2-5-2-4), the speaker ANTI-TRIP control is advanced to a setting where the audio signal picked up by the microphone from the receiver's speaker will not energize the VOX RELAY. This feature prevents the

adjustments; hence for example, backing off the AUDIO LEVEL control will not reduce the

gain setting is capable of disabling the VOX relay completely, hence the minimum required gain should be

time lag in de-energizing the VOX RELAY when audio excitation is removed from the audio amplifier and VOX amplifier stages. This control should be advanced while speaking into the microphone and set at a position in which the time lapse between words will not de-energize the VOX RELAY. This adjustment will eliminate the constant keying of the HT-32A Transmitter/Exciter at the beginning of each word when speaking. There is a slight interaction between the VOX and DELAY circuits, consequently it may be necessary to obtain desired results. The VOX DELAY adjustment (R49A) is the center shaft with the screwdriver slot. See Figure 9. For adjustment instructions concerning the sleeve shaft (CW DELAY), see paragraph 4-4, step 9.

4-9. USE OF ANTI-TRIP CONTROL.

This control is located on top of the HT-32A Trans-

This control has been factory set for -49V as measured at the adjacent TEST terminal with the transmitter operating from a 117V line.

The control is located to the rear of the chassis and slightly to the right of center. (See Figure 7).

An occasional check with an accurate, high resistance voltmeter will insure maximum tube life since the 6146 final amplifier tubes are operated close to rated plate dissipation for optimum performance. Do not adjust the bias for maximum sensitivity.

To adjust the bias, set the OPERATION switch at MOX, FUNCTION switch at either sideband (zero signal) and adjust for $-49V \pm 1V$ with the voltmeter connected between the test point terminal (-) and chassis (+). Note polarity since this is a bias voltage.

Note that the bias voltage specified is for operation from a 117V line and that it will rise and fall with the

source voltage. In cases where the power source voltage cannot be set at 117V to make the bias adjustment, make allowances for it when setting the bias. For example, if the line voltage measures 112V, set the bias at -47V; if at 115V, set at -48V; if at 120V, set at -50V; and if at 122V, set at -51V.

Setting the bias abnormally high or low because of meter errors etc., will not only affect the final tubes but the over-all transmitter performance as well, since the bias level also controls the over-all transmitter sensitivity.

4-11. MODEL HT-32A TRANSMITTER/EXCITER WITH LINEAR POWER AMPLIFIER.

When the Model HT-32A Transmitter/Exciter is used to drive a linear amplifier, swamping or padding between the units may be required for optimum performance.

The degree of swamping or padding will depend upon the driving power required by the linear amplifier. High powered grounded grid or triode amplifiers generally will require little or no swamping since the driving power will be essentially equal to the power output capabilities of the HT-32A Transmitter/Exciter. Linear power amplifiers using tetrodes or pentodes on the other hand generally require considerably less than the peak power output available from the HT-32A Transmitter/Exciter.

In general the swamping between units should "soak" up the unused driving power so that the driver unit (HT-32A) is running reasonably close to its peak power output and terminated in a 50-ohm load. This condition will retain the carrier suppression of the HT-32A Transmitter/Exciter for the overall system as well as hum and noise ratio which are all related to the peak envelope power output.

For example - Should the linear power amplifier require 40 to 50 watts of drive, then a 3DB T pad designed for 50-ohm terminations would fully load the HT-32A Transmitter/Exciter while still transferring the required driving power to the final amplifier grids.

4-12. SERVICE OR OPERATING QUESTIONS.

For further information regarding operation or servicing of your Model HT-32A Transmitter/Exciter, write to:

General Service Manager
The Hallicrafters Co.
4401 West Fifth Avenue
Chicago 24, Illinois

Be sure to include the model, serial, mark number, and date purchased.

Make no service shipments to the factory unless instructed to do so by letter. The Hallicrafters Company will not accept the responsibility for unauthorized shipments.

The Hallicrafters Company reserves the privilege of making revisions in current production of equipment and assumes no obligation to incorporate these revisions in earlier models.

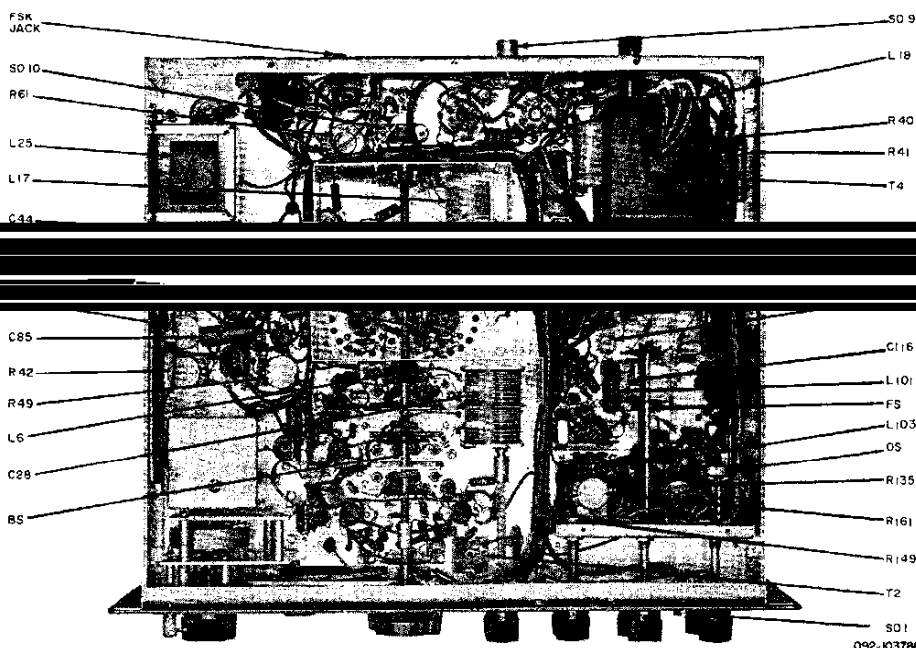

Figure 8-2-1 Transmitter Chassis

SECTION V

BASIC OPERATING THEORY

5-1. BASIC OPERATING PRINCIPLES.

The basic operating principles of the Model HT-32A Transmitter/Exciter is explained in the following subparagraphs. Figure 11 is a block diagram of the HT-32A Transmitter/Exciter and figure 14 is the schematic diagram. The complete system is first discussed for SSB operation and a brief description of CW and AM operation follows.

5-2. GENERAL DESCRIPTION.

Tube V1A is a 4.95 MC crystal controlled oscillator; its output frequency is ultimately converted to the desired operating frequency by heterodyne action in the succeeding stages. The output of V1A is a 4.95 MC signal which is fed directly to the tank circuit of the bridged-T modulator network. The audio input is impressed across diode modulator V14 which is part of the grounding leg of the bridged-T modulator network. The proper phase relation has been obtained by the CARRIER BALANCE controls.

In SSB operation, (FUNCTION switch in UPPER SB or LOWER SB position), the bridged-T modulator network is placed in a balanced condition and carrier output is at least 50 db below peak envelope power. Under balanced conditions, the output of the bridged-T modulator network consists of the upper and lower sideband of 4.95 mc. A filter system, in the input and output circuits of the sideband filter amplifier stage, V2, suppresses the lower sideband of the modulated 4.95 mc signal. The upper sideband is fed to the 1st mixer, V3, where it is combined with 4.05 mc or 13.95 mc, as selected, from V4. The oscillator frequency used determines whether the upper or lower sideband is transmitted. For example:

1. Upper sideband - the upper sideband of 4.95 mc is mixed (sum) with 4.05 mc to obtain the upper sideband at 9 mc. The inter-stage coupling between 1st mixer, V3, 9 mc ampli-

2. Lower sideband - the upper sideband of 4.95 is mixed with 13.95 mc to obtain the lower sideband at 9 mc. As in the upper sideband condition, the inter-stage coupling of V3, V5, and V7 pass only the frequencies near 9 mc.

Up to the input stage of 2nd mixer, V7, the operation of the HT-32A Transmitter/Exciter is identical on all bands. The remaining stages "beat" (sum or difference) the selected 9 mc sideband to the desired operating frequency. Frequency multiplication cannot be used since doubling the frequency would double the spacing of the sidebands. This would change the relative frequency of the modulating frequencies when the signal is detected.

5-3. 80 METER OPERATION.

The selected sideband (upper or lower) at 9 mc is amplified by 9 mc amplifier, V5, and fed to the 2nd mixer V7. On 80 meters, heterodyne oscillator, V6, has no output and the 2nd mixer, V7, functions as an additional amplifier. At the 3rd mixer, V8, the sideband is mixed (difference) with the output frequency of the VFO, V9. Since the VFO output frequency is tunable from 5.0 to 5.5 mc, the difference output of V8 is the sideband of a frequency between 3.500 to 4.000 mc.

5-4. 40 METER OPERATION.

The selected sideband at 9 mc is mixed (difference) with a 21.5 mc output of heterodyne oscillator V6 in 2nd mixer, V7. The output of V7 is a sideband at 12.5 mc which is applied to the 3rd mixer, V8. In this stage, the signal is mixed (difference) with the VFO output (5.0 to 5.5 mc); the resulting signal is the sideband of a frequency between 7.000 to 7.500 mc.

5-5. 20 METER OPERATION.

Operation on 20 meters is essentially the same as 80 meters except that "sum" mixing is employed in place of "difference" mixing at 3rd mixer, V8. When the VFO output (5.0 to 5.5 mc) is mixed with the upper or lower sideband at 9 mc, the resulting signal is the sideband of a frequency between 14.000 mc to 14.5 mc.

5-6. 15 METER OPERATION.

The selected sideband (upper or lower) at 9 mc is mixed (difference) at 2nd mixer, V7, with a 25 mc signal from heterodyne oscillator V6; the output of V7 is a sideband of a 16 mc signal. This signal is applied to 3rd mixer, V8, where it is mixed (sum) with the 5.0 mc to 5.5 mc output of the VFO, V9. The result of the mixing action is a sideband of a frequency from 21.0 mc to 21.5 mc.

5-7. 10 METER OPERATION.

1. 28 mc to 28.5 mc. - The selected sideband at 9 mc is mixed (difference) at 2nd mixer, V7, with a 32.0 mc signal from heterodyne oscillator V6. The resulting signal, a sideband at 23.0 mc is applied to 3rd mixer, V8. In this stage, the sideband at 23.0 mc is mixed (sum) with the VFO output (5.0 mc to 5.5 mc). The resulting signal is a sideband at a frequency between 28.0 mc to 28.5 mc.
2. 28.5 mc to 29 mc. - For this range, the 9 mc sideband is mixed (difference) with the 32.5 mc signal from heterodyne oscillator V6, in 2nd mixer V7. The resulting signal, a sideband at 23.5 mc, is mixed (sum) in the 3rd mixer, V8,

with the 5.0 mc to 5.5 mc output of the VFO. The output of V8 is a sideband at a frequency between 28.5 mc to 29 mc.

3. 29 mc to 29.5 mc - As in the above two ranges, the selected sideband of the 9 mc signal from V5 is applied to 2nd mixer, V7. Here it is mixed (difference) with the 33 mc output of V6. The output of V7 is a sideband at 24 mc. This signal is mixed (sum) in 3rd mixer, V8, with the VFO output. The resulting signal is a selected sideband at a frequency between 29 mc to 29.5 mc.
4. 29.5 mc to 30 mc. - For operation in this range, the heterodyne oscillator, V6, injects a 33.5 mc signal in V7 and is mixed (difference) with the selected sideband at 9 mc. The resulting frequency, a sideband at 24.5 mc is mixed (sum)

VFO. The output of V8 is a sideband at a frequency between 29.5 mc to 30 mc.

5-8. CW OPERATION.

When the FUNCTION control is set to CW or DSB position it unbalances the "bridged-T" modulator network, allowing a carrier to be amplified and heterodyned to the desired output frequency. Two sections of the FUNCTION switch bypasses the 4.95 mc filter (V2 and associated circuitry) in the "CW" or "DSB" position. With these exceptions, CW operation is the same as SSB operation.

5-9. DSB (AM) OPERATION.

As in CW operation, the carrier frequency is present in the signal and the 4.95 mc filter is bypassed. Amplitude modulation of the carrier occurs across diode modulator V14. The resulting signal is amplified and heterodyned to the CW or DSB position.

SECTION VI

SERVICE DATA

6-1. TECHNICAL SPECIFICATIONS.

TUBES..... 17 plus 1 voltage regulator and
2 voltage rectifiers
POWER SOURCE... 105-125 volts, 50/60 cycles AC
POWER OUTPUT:
SSB (PEP)..... 70-100 watts
CW..... 70-100 watts
AM (CARRIER)..... 17- 25 watts
AUDIO INPUT..... 0.004V rms minimum
STABILITY..... 0.009% maximum
HUM AND NOISE OUTPUT..... At least 40 db below
carrier
UNWANTED BEAT OUTPUT.... At least 55 db below
carrier
FREQUENCY COVERAGE..... 80, 40, 20, 15, and
10 meter bands
FREQUENCY SELECTION..... Self contained VFO
DIMENSIONS..... 10-3/8" Height,
18" Deep, 20" Wide
SHIPPING WEIGHT..... 85-1/4 lbs.

6-2. CHASSIS REMOVAL.

The chassis and front panel assembly are removable as a unit from the cabinet by removing 2 screws at each side of the front panel and the 3 screws on the underside of the cabinet.

6-3. TUBE AND DIAL LAMP REPLACEMENT.

Access to the dial lamps and all tubes may be obtained by raising the top cover of the cabinet.

6-4. SERVICING THE HT-32A TRANSMITTER/EXCITER

Throughout the design of the Model HT-32A Trans-

mitter/Exciter, full consideration was given to keep maintenance problems at an absolute minimum. In all well designed communications equipments, maintenance and repair problems are generally confined to the checking and replacement of tubes which may become defective. Malfunctions of this nature are easily isolated and corrected. However, it is entirely possible that a more obscure malfunction may arise. In this event, only thoroughly trained technical personnel should attempt servicing the unit.

A recommended aid for troubleshooting the HT-32A Transmitter/Exciter is a general coverage receiver. This receiver can be used to provide a quick check on various oscillator circuits in the HT-32A. A lead connected to the antenna of this general coverage receiver when placed in the proximity of the oscillator tube in the circuit to be checked can determine the presence or absence of signal from the stage in question.

NOTE

The frequencies of the various crystals can vary somewhat from the frequencies marked thereon. The frequencies of all the mixer stages can also vary to some degree.

If a malfunction occurs when operating on one particular band and mode of operation, the unit should be checked on all other bands and in all other modes of operation to isolate the difficulty. A careful study of the block diagram (See Figure 11) should give a quick clue as to which tubes should be checked. The schematic diagram (Figure 14) voltage chart (Figure 12) and resistance chart (Figure 13) and the following table will prove to be a valuable aid in isolating and correcting a malfunction.

TROUBLE SHOOTING CHART	
Symptom	Possible Cause
No output any band any mode	Check V1, V14, V2, V3, V5, V7, V8, V9, V10, V11 and V12.
No output any band SSB only	Check V2
No output 80 Mtrs. USB LSB AM-CW	Check V4 4.05 MC Check V4 13.95 MC Check V4 13.95 MC
No output 40 Mtrs. All Modes USB LSB AM-CW	Check V6 21.5 MC Check V4 13.95 MC Check V4 4.05 MC Check V4 4.05 MC
No output 20 Mtrs. USB LSB AM-CW	Check V4 4.05 MC Check V4 13.95 MC Check V4 13.95 MC
No output 15 Mtrs. All Modes USB LSB AM-CW	Check V6 25 MC Check V4 13.95 MC Check V4 4.05 MC Check V4 4.05 MC
No output 10 Mtrs. All Modes USB LSB AM-CW	Check V6 Check Xtal frequency of portion in use. Check V4 13.95 MC Check V4 4.05 MC Check V4 4.05 MC
No Vox Operation Vox will not drop out	Check V15, V16, V17 Check for Hum V13, V15, V17 Check V15, V16, V17

SECTION VII

HT-32A ALIGNMENT PROCEDURES

(Figures 9 and 10 Cover These Procedures)

7-1. EQUIPMENT REQUIRED.

1. RF Signal Generator - Measurements Corp. Model 65B or equivalent having a 1V RMS output at an impedance of 70 OHMS or less. (A 100 mmf DC blocking capacitor must be placed in series with the RF lead.)
2. Vacuum tube voltmeter (VTVM) - Hewlett Packard 410A or equivalent having an RF probe good to 35 MC.
3. Dummy load - 50 ohms non-inductive, rated at 100 watts. The dummy load may be made up of carbon resistors, Bird Wattmeter, or equivalent.
4. DC Milliammeter 0 - 300 MA DC.
5. DC Voltmeter with 20,000 ohm per volt sensitivity.
6. Receiver (3-30 MC range) with 50 KC calibrator. (Essential adjustments can be done with 100 KC calibrator.)

7. Audio Frequency Signal Generator covering range of 100 CPS to 5000 CPS.
8. Ballantine voltmeter or equal capable of reading 2 to 4 millivolt level.

7-2. INITIAL CONTROL SETTINGS.

OPERATION	STANDBY (Power on)
FUNCTION	DBS
CALIBRATE LEVEL	0
DRIVER TUNING	Fully counterclockwise (Closed gang)
FINAL TUNING	ON INDEX (Closed gang)
FREQUENCY	Fully counterclockwise (Closed)
BAND SELECTOR	As instructed
AUDIO LEVEL	0
METER COMPRESSION	10
RF LEVEL	0

7-3. BIAS ADJUSTMENT.

Check the bias voltage before running any extensive checks with the plate and screen voltage applied to the 6146 final amplifier tubes. Set BIAS ADJ. for -49V

DC $\pm 1V$ with the OPERATION switch at MOX, FUNCTION switch at either upper or lower sideband (zero signal). Line voltage 117V. See paragraph 4-10 for additional comments on bias adjustments.

7-4. RF ALIGNMENT 2ND AND 3RD MIXER AND DRIVER STAGES.

IMPORTANT: The RF alignment should only be attempted when an HT-32A Transmitter/Exciter malfunction has been analyzed and definitely traced to RF misalignment.

Remove 21.5, 25, and 32.5 MC Xtals; Osc. Tube V9;

HV Rect V18; and 9 MC RF cable from SB generator.

7-4-1. 3RD MIXER AND DRIVER STAGES.

Disconnect screen lead of V11 (6146, Final Amp) from lug at terminal board on underside of chassis. Set neutralization capacitor C44 and VFO coupling capacitor C15 at mid-capacity, if these components are new and have never been adjusted before.

To place the transmitter in operation for alignment, set OPERATION control at MOX. This places operating bias on the 2nd and 3rd mixer stages.

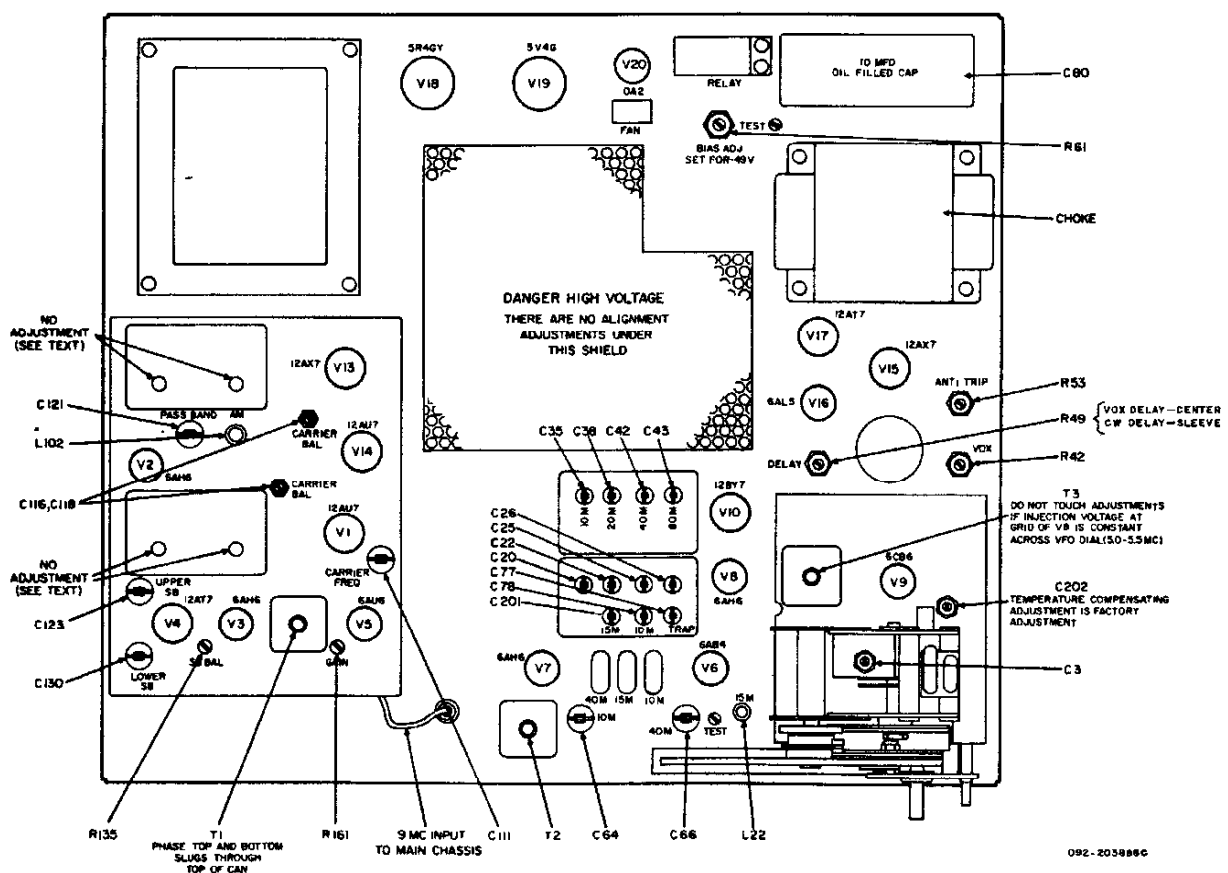

Figure 9. Top Chassis Alignment Points

7-4-1. 3RD MIXER AND DRIVER STAGES (CONT.).

ALIGNMENT CHART									
Step	Band	Signal Generator Connection	VTVM Connection	Trimmer Adjust for Maximum	Coil Adjust for Maximum	Signal Generator Freq. MC		Approx. Driver Tuning Setting	
						f ₁	f ₂	D ₁	D ₂
1	80M	High Side to Pin #1 grid of V8 (6AH6, 3rd Mixer) Common side to chassis. (Generator leads must be kept to absolute minimum to prevent re-generation.)	VTVM to Pin #5 grid of V11 (6146 Final Amp.) Common to chassis.	C26 C43	L7 L11	3.5	4.0	1.3	3.7
2	40M	Same as step 1.	Same as step 1.	C25 C42	L6 L10	7.0	7.3	0.9	4.1
3	20M	Same as step 1.	Same as step 1.	C22 C38	L5 L9	14.0	14.35	1.1	3.7
4	15M	Same as step 1.	Same as step 1.		L5 L9	21.0		1.8	
5	10M	Same as step 1.	Same as step 1.	C20 C35	L4 L8	28.0	29.7	1.2	4

7-4-2. ALIGNMENT PROCEDURE.

- The 3rd mixer and driver stages alignment procedure for 80, 40, 20 and 10 meter bands, is essentially the same, differences being only in frequency used and adjustment location which can be obtained from the chart above. The following is the alignment procedure for 80 meters. Preset the Initial Control Settings with the BAND SELECTOR set on the band being

flection on VTVM. Driver tuning setting should be approximately D₂ (3.7 on the Knob).

- Adjust trimmers (C26 and C43) for maximum deflection on VTVM.
- Repeat steps (c) thru (h) until the adjustments result in no appreciable increase in

- Set trimmers (C26 and C43) to mid-capacity.
- Preset slugs (L7 and L11) to their maximum inductance if they have never been previously aligned.
- Set the DRIVER TUNING to D₁ (1.3 on Knob).
- Set the R. F. Generator to f₁ (3.5 MC) using sufficient generator output to obtain a readable indication on the VTVM. If 1V out of the signal generator does not provide a VTVM reading proceed with slug adjustment below.
- Carefully adjust each slug (L7 and L11) for maximum deflection on VTVM. Use reference voltage on VTVM of approximately 20V RMS.
- Adjust the output frequency of the R. F. generator to f₂ (4.0 MC) using sufficient generator output to obtain about 20V RMS at the grid.
- Tune DRIVER TUNING for maximum de-

- The 3rd Mixer and Driver Alignment procedure for 15M is slightly different, since the 20M and 15M bands share the same coil. The following is the alignment procedure for 15 meters.

- Align 20 meter band as outlined above.
- Set BAND SELECTOR at 15M.
- Set the R. F. generator at f₁ (21.0 MC) using sufficient generator output to obtain about 20V RMS at the grid of the final amplifier
- Tune DRIVER TUNING for maximum deflection of VTVM. Driver tuning setting should be approximately D₁ (1.8 on the knob).
- Adjust slugs (L5 and L9) for maximum deflection of VTVM. If additional gain is obtained with this adjustment, repeat 20 meter trimmer alignment at 14.35 MC and check 14.0 MC for uniform gain on 20M band.
- Repeat above procedure until no further gain can be obtained on both bands.

7-4-3. 2ND MIXER STAGE.

ALIGNMENT CHART								
Step	Band	Signal Generator Connection	VTVM Connection	Trimmer Adjust for Maximum	Slug Adjust for Maximum	Signal Generator Freq. (MC)		VFO Freq. (MC)
						f_1	f_2	
1	40M	High side to pin #1 grid of V7 (6AH6, 2nd Mixer). Common side to chassis.	VTVM to pin #5 grid of V11 (6146, Final Amp.). Common to chassis.		L23	7.2	12.5	7.2
2	15M	Same as step 1.	Same as step 1.	C201		21.0	16.0	21.0
3	10M	Same as step 1.	Same as step 1.	C78		29.0	23.5	29.0

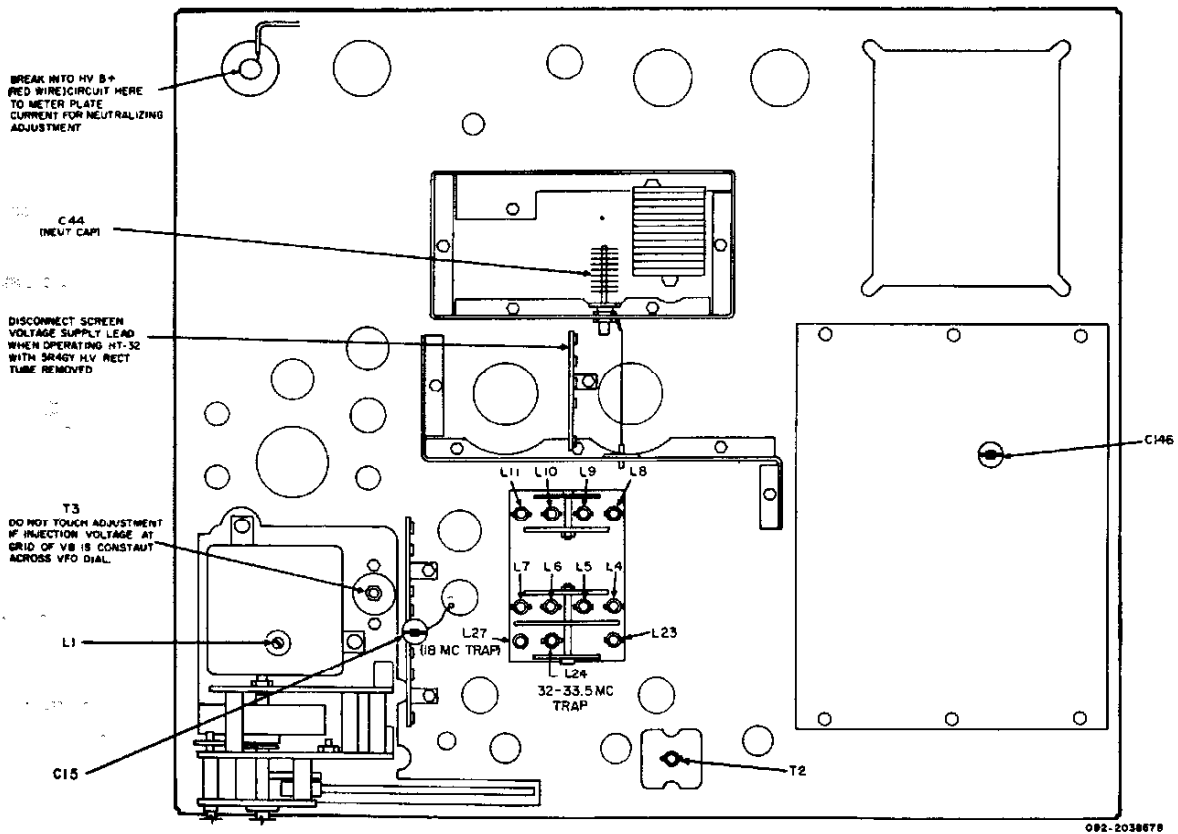

Figure 10. Bottom Chassis Alignment Points

7-4-4. ALIGNMENT PROCEDURE.

The 2nd mixer alignment procedure must follow the sequences shown in the chart, since the setting of the coil inductance on 40M must precede the trimmer adjustments on 15M and 10M bands. The following is the alignment procedure for 40 meters.

1. Set BAND SELECTOR at 40M.
2. Set trimmers C201 and C78 at mid-capacity.
3. Set slug (L23) at it's maximum counterclockwise position (minimum inductance).
4. Set Signal generator at f_1 (7.2 MC) with sufficient output to permit setting the driver tuning to resonance.
5. Adjust DRIVER TUNING for maximum deflection on VTVM.
6. Set VFO dial to 7.2 MC.
7. Set R. F. generator at f_2 (12.5 MC). Set generator output for approximately 20V RMS at the final grid while making alignment adjustments.

8. Adjust mixer coil slug L23 for maximum deflection on VTVM.
9. Proceed with the alignment of the 2nd mixer stage on 15M and 10M using the chart and the above procedures used on 40M.

NOTE

The above alignment data for 10M 2nd mixer adjustment covers the 28.5-29.0 MC 10M segment (32.5 MC Xtal) supplied with the HT-32A Transmitter/Exciter. For alignment instructions covering the use of other 10M 0.5 MC segments, refer to SEGMENT ALIGNMENT for 10M BAND in paragraph 4-7.

The 2nd mixer plate frequency (f_2) for the various crystals used on the 10M band are as follows:

Trans. Freq. range	Xtal freq.	2nd Mixer freq. (f_2)
28.0 - 28.5 MC	32.0 MC	23.0 MC
28.5 - 29.0 MC	32.5 MC	23.5 MC
29.0 - 29.5 MC	33.0 MC	24.0 MC
29.5 - 30.0 MC	33.5 MC	24.5 MC

7-5. HETERODYNE XTAL OSCILLATOR ALIGNMENT.

ALIGNMENT CHART					
Step	Band Selector	VTVM Connection	Trimmer Adjustment	Coil Adjustment	Injection Level
1	15M	VTVM to pin #1 of V7 (6AH6, 2nd Mixer). Common side to chassis.		L22	0.25V RMS
2	40M	VTVM to pin #1 of V7 (6AH6, 2nd Mixer). Common side to chassis.	C66		0.5 V RMS
3	10M	VTVM to pin #1 of V7 (6AH6, 2nd Mixer). Common side to chassis.	C64		0.5 V RMS

7-5-1. ALIGNMENT PROCEDURE.

The heterodyne crystal oscillator alignment procedure must follow the sequence shown in the chart, since the setting of the coil inductance on 15M must precede the trimmer adjustments on 40M and 10M bands. Set RF LEVEL at 0, FUNCTION switch at DSB, and OPERATION switch at MOX.

1. Set BAND SELECTOR at 15M.
2. Adjust Xtal Osc coil slug (L22) for 0.25V RMS on the gentle slope side of resonance.
3. Set BAND SELECTOR at 40M.
4. Adjust Xtal Osc trimmer C66 for 0.5V RMS on the gentle slope side of resonance.
5. Set BAND SELECTOR at 10M.

6. Adjust Xtal Osc trimmer C64 for 0.5V RMS on the gentle slope side of resonance.

7-6. VFO CALIBRATION ALIGNMENT.

The VFO unit has been carefully aligned and temperature compensated at the factory. Before touching up trimmer C3 or coil L1, check the dial calibration at the 100KC points. If all points fall to one side of the pointer, reset the pointer position. If the calibration "runs out" across the dial, proceed as follows:

1. Set OPERATION control at STANDBY.
2. Place the antenna lead of the receiver near the VFO unit and set the receiver at 5.0 MC with the 50 KC calibrator. Receiver BFO turned off.
3. Tune the VFO unit to 4000 KC on 80M.

4. Adjust slug L1 for zero-beat.
5. Set the receiver to 5.5 MC with the 50 KC calibrator at zero beat.
6. Tune the VFO unit to 3500 KC on 80M.
7. Adjust air trimmer C3 for zero beat.
8. Repeat steps 2, 3, 4, 5, 6, and 7 until calibration is obtained at either end of the dial scale.

7-7. RF ALIGNMENT 9MC AMPLIFIER STAGES.

Signal Generator Connection	Signal Generator Frequency	VTVM Connection	Control Setting	Remarks
High Side to Pin #1 Grid of V3 (6AH6, 1st Mixer) Com-	9 MC (Unmod.)	VTVM RF probe to pin #5 Plate of V7 (6AH6, 2nd Mixer.) Common side to	BAND SELECTOR, 20M. OPERATION, Standby. RF LEVEL, 10. (All	Remove OSC. tubes V1, V4. Peak upper and lower core ad-

7-8. CARRIER OSC. AND SIDEBAND SWITCHING OSC. ALIGNMENT.

The carrier oscillator and sideband switching oscillators are provided with minor frequency correction trimmers which permit setting each oscillator to exact frequency. The object of the oscillator frequency adjustment in the sideband generator unit is to provide a carrier signal frequency of exactly 9000 KC. This is accomplished by heterodyning the carrier oscillator frequency (4950 KC) with either the 4050 KC or 13,950 KC sideband switching oscillator to produce a 9000 KC signal at the output of the sideband unit.

7-8-1. CARRIER OSCILLATOR.

Ordinarily the carrier oscillator will not require adjustment in the field. If the 9 MC signal is not on frequency, adjust the sideband switching oscillators only. In cases where the carrier oscillator frequency must be set, proceed as follows:

1. Set the OPERATION switch at the MOX position.
2. Set the FUNCTION switch at DSB.
3. Tune up the transmitter on 80M into a dummy load.
4. Reset the FUNCTION switch for either USB or LSB.
5. Set the two CARRIER BAL. trimmers on the sideband unit for maximum carrier level and if necessary detune with the DRIVER TUNE control to prevent over-driving the final.
6. Adjust the CARRIER FREQ. trimmer (C-111) for maximum carrier level, again detuning with the DRIVER TUNE control to prevent driving the final stage into a saturation output.

uration level. Set the output meter sensitivity for zero DB

8. Decrease the carrier oscillator frequency by turning the CARRIER FREQ. trimmer until the carrier level drops 20DB to 30 DB

NOTE. The carrier oscillator frequency may not fall exactly on 4950 KC which is stated in the manual as the nominal frequency.

9. Rebalance for maximum carrier suppression with the carrier balance trimmers. Retune the driver stage and check the low frequency audio response. Use a 50V RMS RF output level at 1000 CPS audio reference frequency. The low frequency response for -3DB will fall between 500 CPS and 650 CPS.

NOTE. The low frequency audio response is directly governed by the CARRIER OSCILLATOR frequency. The carrier frequency is set in this manner to insure carrier suppression of 40 DB or more after a 30 minute warm-up.

10. Check the audio frequency response at the high end of the range. The output level should fall -3 DB at 3000 to 4000 CPS. If adjustment is required, adjust the AM coil (L-102) for the correct response.

NOTE. A change in the AM coil adjustment will generally require an adjustment of trimmer C-146, in order to repeak the carrier level output for DSB or CW operation.

11. After the carrier frequency has been set, it is now necessary to adjust the sideband switching oscillators for exactly 9000 KC from the sideband unit as described in par. 7-8-2.

7-8-2. SIDEBAND SWITCHING OSCILLATORS.

7. Set the carrier level with the DRIVER TUNE

1. Set band switch at 80M

3. Place antenna lead of receiver near the center terminal of the shielded plug and set the receiver at 9000KC, with the crystal calibrator. Receiver BFO turned off.
4. Set the FUNCTION switch at LSB.
5. Adjust LOWERSB osc. trimmer (C130) for zero beat.
6. Set the FUNCTION switch at USB.
7. Adjust UPBERSB osc. trimmer (C123) for zero beat.
3. Remove heterodyne oscillator tube (V6) and 9 MC output cable from sideband generator unit.
4. Connect 0-300 MA milliammeter in H. V. plate lead between the filter capacitor (C80) and shunt feed choke (L16).
5. Insert HV rectifier and reconnect screen supply lead.
6. Set neutralizing capacitor at mid-capacity.
7. Set OPERATION switch at MOX. and frequency dial at mid position.

NOTE: It may be desirable to unbalance the carrier balance adjustments slightly to obtain a higher signal level for the receiver.

7-9. SIDEBAND BALANCE ADJUSTMENT.

The SB BAL control is a potentiometer (R-135) in the cathode circuits of the 4.05 MC oscillator and 13.95 MC oscillator (V4) stages. This control is utilized to maintain sideband amplitude symmetry and may not require adjustment throughout the use of the HT-32A Transmitter-Exciter. However, if adjustment is necessary, proceed as follows:

1. Tune the HT-32A Transmitter-Exciter for SSB operation, using a 1000 CPS audio tone.
2. Set the FUNCTION switch at "UPPER SIDEBAND" and note the reading of the front panel meter. Set AUDIO LEVEL control for approximately mid-scale reading.
3. Set the FUNCTION switch at "Lower Sideband". The meter indication for both "UPPER" and "LOWER SIDEBAND" should be essentially the same. Any difference in output between the 4.05 MC oscillator and 13.95 MC oscillator can be compensated by adjusting the SB BAL control. Rotating the SB BAL control will increase the output of one sideband and decrease the other simultaneously. Consequently, it is necessary to alternate between the "UPPER" and "LOWER SIDEBAND" positions of the FUNCTION switch, checking for equal output, while adjusting the SB BAL control.
4. There is a slight interaction between the SB BAL adjustment and SB frequency adjustment, hence a relatively large change in one will affect the performance of the other. If a large correction in sideband balance is required, check the sideband switching oscillator frequency adjustment again.
8. Set BANDSWITCH at 10M, signal generator at 23 MC and adjust DRIVER and FINAL TUNING for maximum output. Set signal generator output for 150-175 ma plate current.
9. Tune FINAL TUNE control for plate current dip and observe output meter. Adjust neutralization capacitor until the output meter passes through maximum at the same time the plate current passes through the resonant dip.
10. Set BANDSWITCH at 15M, signal generator at 16 MC and repeat the above procedure.
11. If the neutralization capacitor setting does not change, the adjustment is complete. If a small change in setting occurs, set the capacitor half way between the two settings and recheck with this compromise setting.

7-11. CARRIER BALANCE ALIGNMENT.

The CARRIER BAL C116 and C118 are air trimmers located at the top side of the sideband generator unit. The adjustment of trimmer C116 tunes the Bridged T coil to resonance and the adjustment of trimmer C118 adjusts the phase of the Bridged T network so that the carrier frequency is balanced out, when operating in either side band position of the FUNCTION switch. The best working carrier balance adjustment will be obtained if adjustment is made after the transmitter has reached a normal operating temperature, which is usually in about 2 to 3 hours.

1. Tune the HT-32A Transmitter/Exciter for DSB operation.
2. Set FUNCTION switch to one sideband position.
3. Adjust C116 and C118 systematically for maximum carrier suppression. (Minimum output meter reading.)
4. Set FUNCTION switch to the other sideband position.
5. Re-adjust C116 and C118 until the maximum carrier suppression is equalized in both side-

7-10. NEUTRALIZATION OF FINAL AMPLIFIER.

Although a signal generator is used here for this adjustment, the carrier on DSB or CW generated by the transmitter may be used or the 1000 CPS audio tone.

1. Connect dummy load to transmitter output. (The dummy load is connected to the 3rd mixer) through 100 mmf capacitor. Common side to chassis.
2. Connect dummy load to transmitter output.

This adjustment is a coupling trimmer in the output of the VFO unit which governs the amount of VFO injection voltage applied to the 3rd mixer stage.

1. Set BAND SELECTOR at 15M.
2. Set VFO dial to 21, 33 MC.
3. Tune the HT-32A Transmitter/Exciter for DSB operation into 50 ohm load.
4. Disconnect 9 MC cable input from SB generator.
5. Adjust VFO coupling trimmer (C15) for 0.1 RMS RF output across 50 ohms.
6. Connect VTVM probe to pin #1 grid of V8 (6AH6, 3rd Mixer). The injection voltage will be approximately 0.3 to 0.4V RMS. If below 0.3V check screen and bias voltages on tubes V8 and V10 and check tubes V8 and V10 for malfunction.
7. Replace 9 MC cable input from SB generator and tune for maximum saturated power output, which should be at least 60V RMS across 50 ohm load.

7-13. 10 METER TRAP COIL ADJUSTMENT.

This adjustment should be made with a 33.5 MC crystal in the 10 meter heterodyne osc. xtal socket. If the 33.5 MC xtal is not available to the operator, the 32.5 MC xtal supplied with the HT-32A Transmitter/Exciter may be used to adjust the trap coil. However, when higher frequency xtals are installed, the trap coil must then be reset as outlined below.

1. Preset the trap trimmer (C-77) to minimum capacity (slot toward center of RF deck). See Figure 6.
2. Preset the trap coil slug (L-24) for minimum inductance (maximum counterclockwise).
3. Tune the transmitter for CW operation on the 10M band.
4. Set the FUNCTION switch at LSB.
5. Adjust DRIVER TUNING and FINAL TUNING for the spurious output. (33.5 MC Xtal - VFO frequency = 28.0 to 28.5 MC.)
6. Adjust trap coil slug L-24 for minimum output.
7. Increase trap trimmer capacity slightly, and reset the trap coil slug for minimum output. Use just enough capacity in the trap trimmer to observe two resonant dips in the spurious output when the trimmer is rotated through minimum capacity.
8. Set FUNCTION switch at DSB.
9. Tune DRIVER TUNING and FINAL TUNING to desired frequency between 29.5 - 29.7 MC.
10. Readjust 10M 2nd mixer trimmer (C-78) for maximum output with RF LEVEL slightly advanced.
11. Set FUNCTION switch at LSB.
12. Retune DRIVER TUNING and FINAL TUNING for spurious output.
13. Adjust trap coil slug for minimum spurious out-

put and repeat step 10 to be sure the mixer stage is resonant.

14. When crystals other than the 33.5 MC crystals are now used on the 10M band, it is only necessary to adjust the trap trimmer. The trap coil adjustment is left as adjusted for the highest frequency crystal.

7-14. 18 MC TRAP.

The 18 MC trap provides additional suppression of a 28,000 KC, 29,000 KC, 30,000 KC and 31,000 KC spurious signal, generated by the 2nd harmonic of the 9 MC sideband-generator signal beating with the 2nd harmonic of the 23 to 24.5 MC 2nd mixer output. This spurious signal level becomes objectionable when the transmitter is over-driven on CW or SSB. The trap will help to maintain the 50 DB spurious rejection level, but over-driving the equipment is still to be avoided.

7-14-1. 18 MC TRAP COIL ADJUSTMENT.

To check or adjust the 18 MC trap, tune up the transmitter on either 28,000 KC or 29,000 KC in the CW position of the FUNCTION switch (key closed). Leave the RF LEVEL control set for saturated output, zero the output meter with the METER COMPRESSION control, and open the key. Remove the VFO tube V9 (6CB6) and then close the key. If the output meter indicates a spurious signal above the 30 DB point, adjust the trap core (L27) for minimum meter reading. At reasonable drive levels, the spurious level will remain 50 DB or more below the maximum fundamental signal power output when the trap is properly adjusted.

7-15. 9MC GAIN ADJ. ON SIDEBAND UNIT.

This control (R-161) is located on the sideband generator unit and is accessible at the top of its chassis. The control sets the gain of the 9 MC amplifier and is considered a factory adjustment which will generally not require adjustment unless extensive service work has been done on the equipment.

Before changing the adjustment, check the performance of the transmitter as follows:

1. Tune up the transmitter on single sideband using a dummy load. With a 1000 CPS audio oscillator, measure the audio signal level at the microphone connector for peak or saturation power output on each of the bands. AUDIO LEVEL control should be set at 9.
2. The audio signal level at the microphone input should run between 2 to 4 millivolts RMS for saturation or peak power output. Should any one band require substantially more audio signal level than the rest, re-check the alignment on that band.
3. If the audio level required is uniformly higher on all bands, advance the 9 MC amplifier gain adjustment to bring it into agreement with the level specified in step 2. If the audio level required runs less than 2 millivolts, the gain is excessively high and will not permit the carrier suppression and unwanted sideband to reach 50 DB below maximum output. In this case reduce

the gain setting accordingly.

7-16. CRYSTAL FILTER ALIGNMENT.

Due to the specialized techniques and test equipment required it is recommended that realignment of

transmitter output for zero DB reference on the output meter with the METER COMPRESSION set for maximum meter sensitivity. This will permit operating the transmitter well below the saturation output level.

1. Tune up the transmitter for single sideband operation into a 50-ohm load.
2. With a 1000 CPS audio generator, adjust the

drop below approximately 3 DB at these extremes of the audio passband. If the transmitter output vs frequency is tilted, the correction may be made by adjusting the PASS-BAND trimmer (C-121) located on the top deck of the sideband unit.

NOTES ON RTTY OPERATION OF THE HT-32A TRANSMITTER/EXCITER

GENERAL.

The Model HT-32A Transmitter/Exciter has the required keying circuit brought out at the rear chassis apron on a three-circuit jack marked FSK. The transmitter may be set-up for teletype operation by connecting a polar relay or polar key board to the three-circuit jack and shifting the frequency of the 13.95 MC side-band switching oscillator in the side-band generator unit. The signal may be directly shifted 850 CPS by resetting the frequency adjustment trimmer marked LOWER SB. If the transmitter is to be used for RTTY and the other normal modes of transmission, it will be better to build-up a simple adapter unit with a separate trimmer set for the required shift in frequency and leave the LOWER SB trimmer adjustment in the transmitter unaltered.

THEORY OF OPERATION.

The sideband switching oscillators (tube V4) operate at either 4.05 MC or 13.95 MC depending upon which side-band is to be transmitted. When either of these two frequencies are mixed with the 4.95 MC signal, the resultant is a 9.0 MC signal at the output of the side-band generator unit.

If the frequency of one of the oscillators is shifted 850 CPS lower in frequency, then as both oscillators are keyed alternately by a RTTY keyer, the required

drop below approximately 3 DB at these extremes of the audio passband. If the transmitter output vs frequency is tilted, the correction may be made by adjusting the PASS-BAND trimmer (C-121) located on the top deck of the sideband unit.

It is not important theoretically which of the two oscillators is changed in frequency from the factory setting, however, the higher frequency oscillator (13.95 MC marked Lower SB) can be more readily shifted with negligible loss of output. Trimmer C130 is used to accomplish this shift. When the trimmer is moved for RTTY, it must be returned to its original factory setting for normal operating modes. See paragraph 7-8-2. It is suggested that a plug-in trimmer be employed to obtain the shift.

PROCEDURE.

1. The adapter unit may consist of a 9-pin test socket adapter (Peco Model TE S9) and ceramic trimmer capacitor (1.5-7 mmf NPO - Erie Resistor Co. Style 555-07). Solder the trimmer between terminals 5 and 7 on the Peco test socket adapter.
2. Remove side-band switching oscillator tube V4 (12AT7) (See Figure 9 for tube location) and plug adapter into the socket. Insert tube in adapter socket.
3. Wire the three-circuit plug to polar relay or polar keyboard. The sleeve of the plug is wired to the movable contact, the ring to one fixed contact, and the tip to the remaining fixed contact. Insert plug in FSK jack.

shift reverses, hence, on 40, 15, and 10 meters the shift is higher.

To disable either of the two oscillator sections of tube V4, blocking bias is applied to the grids via the bandswitch and function switch for normal operation. When changing over to RTTY, the keying plug is inserted at the FSK jack and the keying circuit takes over the switching function of the side-band switching oscillators. Note that the keying plug must be removed to return the transmitter to normal operating modes.

MC oscillator and adjust the adapter trimmer for the 850 CPS shift. To determine which oscillator is working for this adjustment, listen to the beat note in a receiver and touch the adapter trimmer. If the 13.95 MC oscillator is operating, the pitch will change when the finger increases the circuit capacity.

5. To return the transmitter to normal modes of operation, remove both the FSK plug and the adapter unit and replace the tube and shield.

SERVICE PARTS LIST (Cont.)

Schematic Symbol	Description	Hallicrafters Part Number
TRANSFORMERS AND COILS (CONT)		
L25	Choke, Filter (9HY @ 135 MA)	056-300259
L26	Choke, Filter (8HY @ 175 MA)	056-300260
L27	Coil, Trap (18 MC)	051-202656
L101	Coil, Modulator	051-202247

Schematic Symbol	Description	Hallicrafters Part Number
TUBES AND RECTIFIERS (cont)		
V19	5R4GY; H. V. Rectifier	090-900705
V19	5V4G; L. V. Rectifier	090-900721
V20	QA2; Voltage Regulator	090-900001
5Z1	Rectifier, Selenium	090-900004

SWITCHES AND WAFERS

BS1, 2	Wafer, Switch; Sideband Switching Osc. and Heterodyne Osc.	060-200784
BS3	Wafer, Switch; 2nd Mixer	062-200102

KNOB ASSEMBLIES

Knob Assem. ; FINAL TUNE	015-101426
Knob Assem. ; OPERATION	015-101428
Knob Assem. ; FUNCTION	015-101427

FS	Switch, FUNCTION	060-300822
OS	Switch, OPERATION	060-200821

Knob Assem. ; AUDIO LEVEL	015-101425
Knob Assem. ; CALIBRATE LEVEL	015-101425
Knob Assem. ; DIAL DRAG	015-100899
Knob Assem. ; FREQUENCY	015-201429
Knob Assem. ; BAND SELECTION	015-201047
Knob Assem. ; DRIVER TUNE	015-101424

PLUGS, SOCKETS, AND CONNECTORS

P2, 5	Plug, Phono	010-100231
P3	Plug, 10 Pin	006-100715
P4	Plug, 6 Pin	006-100714

SO4	Socket, 6 Pin	006-100713
SO6	Jack, Non-Shorting; KEY	036-100064
SO7	Jack, Shorting; MONITOR	036-100002
SO8	Socket, Control Outlet; 11 Prong Plug, SO8 Mating Connector; 11 Prong	035-100043
SO9	Connector, Coax; RF Output	010-100056
SO10	Socket, AC; Fan	010-200015
SO11	Socket, AC; Accessory Outlet	010-200015
SO12	Connector, MIKE	010-101569
SO13	Jack, Shorting; FSK	036-200194
	Socket Assem., Pilot Light	086-200297
	Socket, Xtal (CR5, CR6, CR7)	006-100320
	Socket, Tube; Octal (Mica) (V11, V12, V18, V19)	006-200760
	Socket, Tube; 7 Pin Min. (Cer.) (V9)	006-100354
	Socket, Tube; 7 Pin Min. (Mica) (V2, V3, V5, V6, V7, V8, V16)	006-200759
	Socket, Tube; 7 Pin Min (V20)	006-100645
	Socket, Tube; 9 Pin W/Base (V1, V4, V10, V13, V14, V15, V17)	006-200672

TUBES AND RECTIFIERS

V1, 14	6680/12AU7; Carrier Osc. and 3rd Audio and Diode Modulator	090-901116
V2, 3, 7, 8	6AH6; Filter Amplifier, 1st Mixer, 2nd Mixer, and 3rd Mixer	090-900793
V4, 17	12AT7; Sideband Switching Osc. and 2nd Anti-Trip Amplifier and Relay Tube	090-900034
V5	6AV6; 9 MC Ampifier	090-900808
V8	6AB4; Heterodyne Osc.	090-900784
V9	6CB6; VFO	090-901115
V10	12BY7; Driver	090-900041
V11, 12	6148; Final Amplifiers	090-900756
V13, 15	ECC83/12AX7; 1st and 2nd Audio, and 1st Anti-Trip and VOX Amplifier	090-901230
V16	6AL5; VOX and Anti-Trip Diode	090-901183

CR5	Osc.; 13950 KC Crystal, Heterodyne Osc.; 21.5 MC	019-201960
CR6	Crystal, Heterodyne Osc.; 25 MC	019-201961
CR7	Crystal, Heterodyne Osc.; 32.5 MC (28.5-29.0 MC) Crystal, 32.0 MC (28.0-28.5 MC)	019-201964
	Crystal, 33.0 MC (29.0-29.5 MC)	019-101965
	Crystal, 33.5 MC (29.5-29.7 MC)	019-201966
CR8	Diode, Rectifier	019-101916

MISCELLANEOUS PARTS

	Cabinet, Foot	016-100029
	Cabinet, Bottom	066-401494
	Channel, Rubber	016-200929
	Connector	010-100961
	Coupler, Solid	029-100264
	Cover, Cabinet Top	066-101451
	Dial Scale, Main Tuning	083-500680
	Escutcheon, Front Panel	007-500659
	Fan Blade	080-300305
	Flywheel	071-100205
	Glass, Dial (Main Tuning)	022-200540
	Grommet, Motor Mounting	016-100034
	Holder, Fuse	006-200845
	Line Cord and Plug (Fan Motor)	087-204833
	Line Cord Lock, Male	076-200756-01
	Line Cord Lock, Female	076-200756-02
M1	Meter, -DB LEVEL INDICATOR	082-400326
	Motor, Fan	020-200218
	Panel, Front	068-400882
	Piute, Foot Reinforcement	063-100334
	Pointer, Dial Scale	082-200320
RY1	Relay, VOX (Voice Control)	021-200442
	Jack, Test (Red)	036-200062

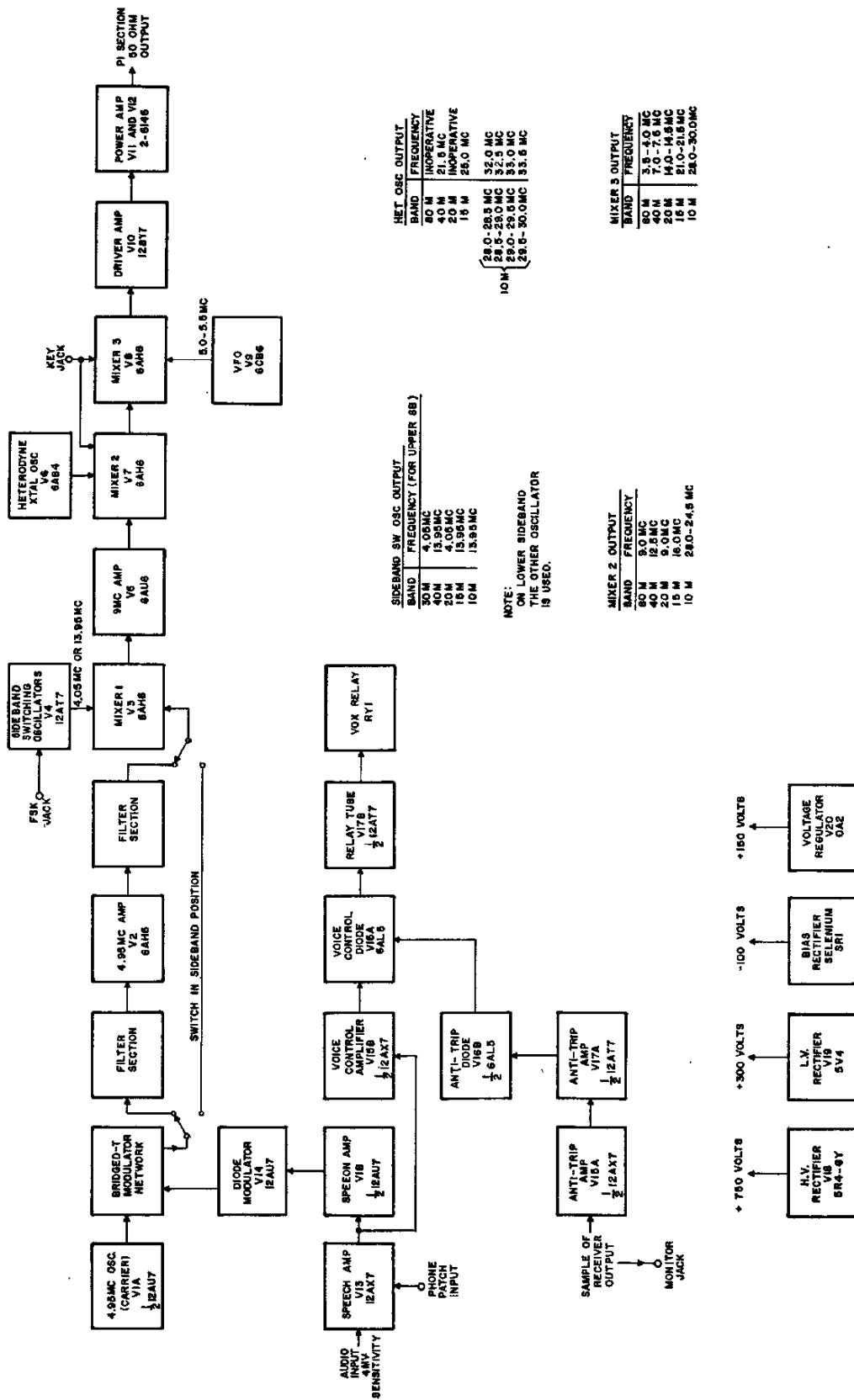

092-303665E

Figure 11. Block Diagram

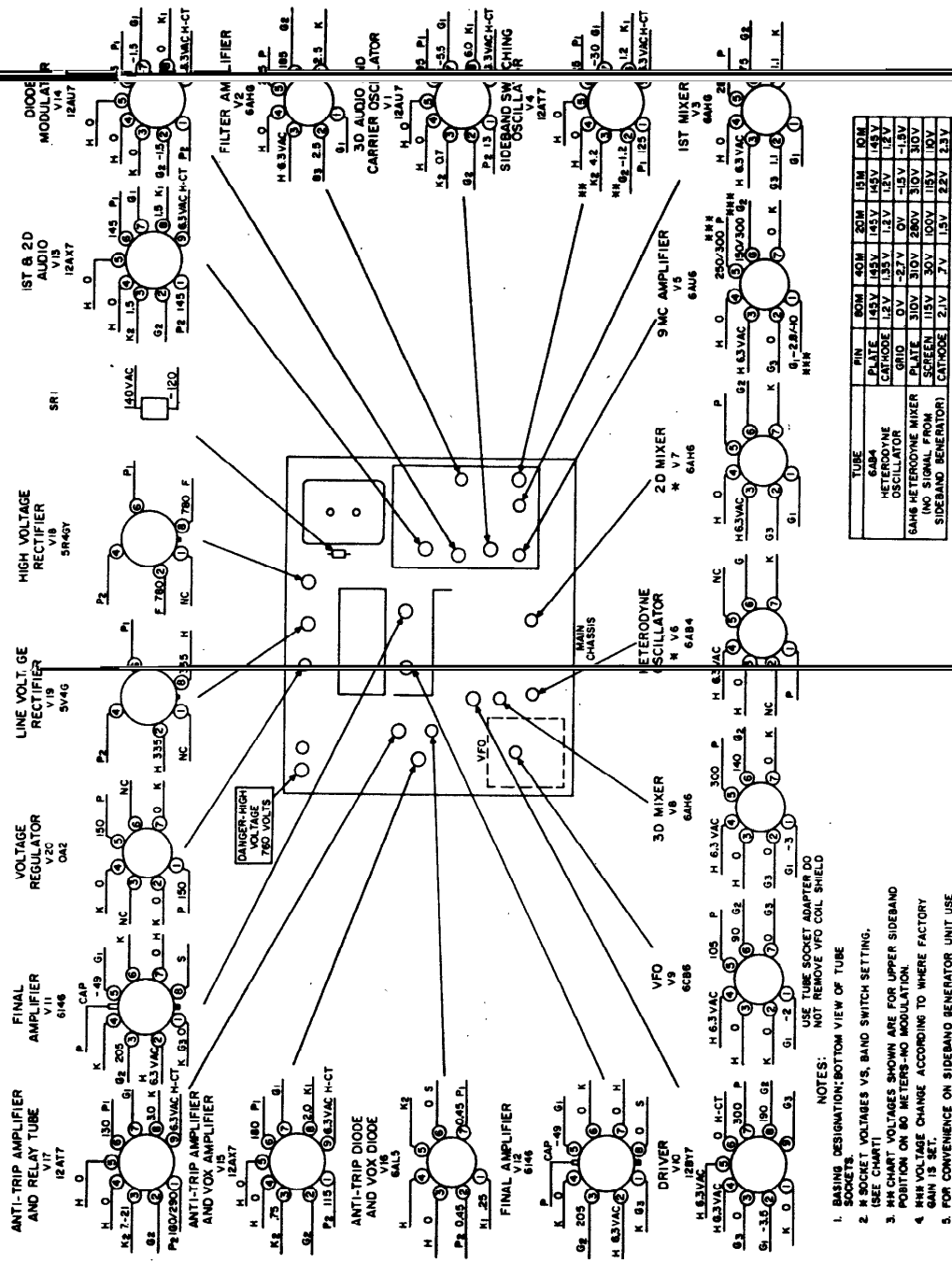

Figure 12. Voltage Chart

