

the hallicrafters Canada, Limited
TORONTO ONTARIO

GENERAL DESCRIPTION

Your Hallicrafters Continental provides reception of both the standard broadcast band and the 6 to 16 megacycle shortwave range. It is a 5 tube superheterodyne radio and is designed to operate from 105 to 125 volt direct current (DC) or 50/60 cycle alternating current (AC).

Fine performance of both standard and shortwave broadcasts can be obtained with the 15 foot antenna wire included with your receiver. It is merely necessary to uncoil this wire, connect one end of it to terminal A1 on the back of the set and then run it about the room in any convenient manner. To complete the antenna installation, the jumper should be connected between terminals A2 and G on the back of the set.

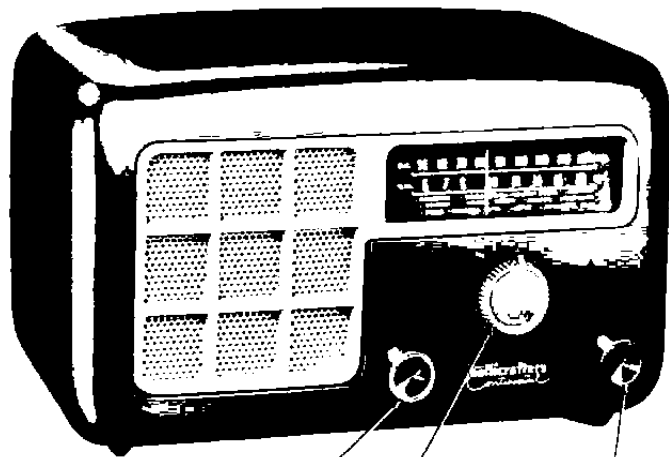

TUNING OFF - ON & VOLUME BAND SWITCH SW - BC
HALLICRAFTERS CONTINENTAL
 92X1589-A

Models 5R30A, 5R31A, 5R32A, 5R33A and 5R34A

For your convenience, the principal shortwave stations of the world have been clearly marked on the dial. Since shortwave reception conditions vary with the season of the year and even with the time of day, shortwave programs may not be heard with the same regularity as standard broadcasts. It is important, therefore, that you refer to the table below as it provides an easy means of selecting the shortwave band most suitable to the time of day.

To get the maximum enjoyment from your Hallicrafters radio, carefully follow the instructions contained in this book.

BEST SHORTWAVE RECEPTION TABLE

BAND	MOST FAVORABLE TIME	MOST FAVORABLE DISTANCE
6-7 MC	Night - Winter	Day-400 Miles Night - Over 1500 Miles
9-10 MC	Day - Late Afternoon and Night - Winter	Over 500 Miles
11-12 MC	Evenings or Late Summer Afternoons	Day - Under 1500 Miles Night - Over 1500 Miles
15-16 MC	Early Mornings and Summer Evenings	Over 1500 Miles

INSTALLATION INSTRUCTIONS

UNPACKING - Check all shipping labels and tags for instructions before removing or destroying them.

LOCATION - Do not locate the receiver close to sources of heat such as radiators and heating vents. Allow for proper ventilation of the receiver by placing it at least two or three inches away from the wall.

ANTENNA - The terminals marked A1, A2 and G on the back of the receiver are for antenna and ground connections. Satisfactory results can be obtained in most localities with the 15 foot antenna wire included with your receiver. This wire should be uncoiled for maximum signal pickup. An outside antenna 30 to 60 feet long may be necessary if the receiver is to be operated in a steel constructed building or in an area surrounded by numerous steel structures. The antenna used should be connected to terminal A1 on the antenna terminal strip. The jumper provided on this strip should be connected between terminals A2 and G. In some locations, reception may be improved by connecting a lead from terminal G to a cold water pipe or other good ground.

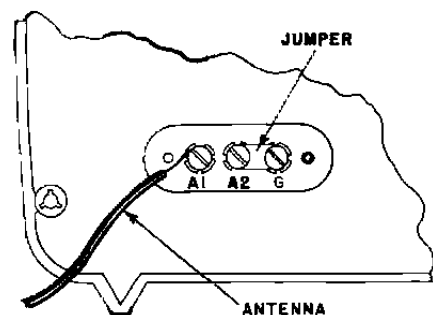

9281567

Fig. 1. Rear View of Receiver Showing Antenna and Ground Connections

OPERATING INSTRUCTIONS

TUNING DIAL

1. The standard broadcast band is calibrated in kilocycles with a zero deleted for convenience. To convert the dial reading to the station frequency in kilocycles, add one zero.
2. The shortwave band is calibrated directly in megacycles.

STANDARD BROADCAST AND SHORTWAVE RECEPTION

1. Plug the power cord into a convenient electrical outlet which provides 105 to 125 volts DC or 50/50 cycles AC. If in doubt about your power supply, call your power company before plugging in the receiver. The wrong power source may cause damage in the receiver.
2. Turn the right hand knob clockwise for standard broadcast reception or counterclockwise for shortwave reception.
3. The large center knob turns the receiver on and off and also controls volume. Turn this knob clockwise to turn the receiver on. Allow about a minute for the receiver to warm up.

NOTE: Allow a minute for the receiver to warm up after the one minute warm up when connected to a DC

5. After the station has been accurately tuned in, adjust the center knob for the desired volume.
6. To turn the receiver off, turn the center knob counterclockwise until a click is heard.

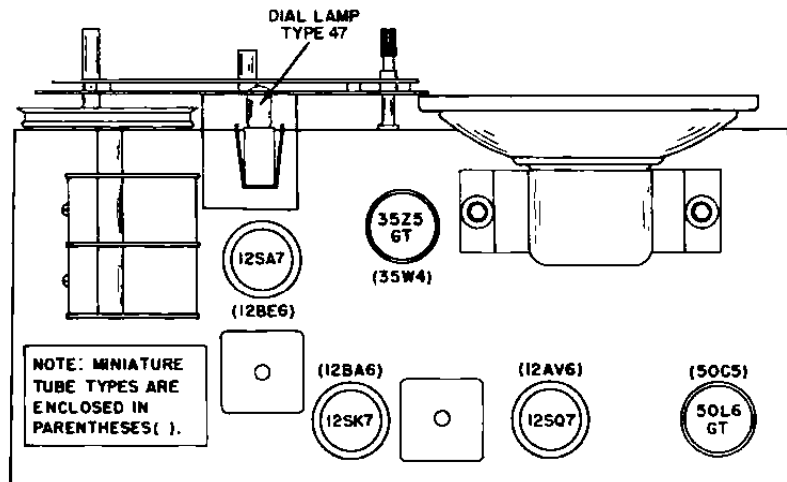

95C1890-A

Fig. 2. Top View of Chassis Showing Location of Tubes and Dial Lamp

SERVICE OR OPERATING QUESTIONS - For further information regarding operation or servicing of your receiver, contact your dealer. Make no service shipments to the factory as the Hallicrafters Co. will not accept the responsibility for unauthorized shipments. Factory type service is available, however, at any HALLCRAFTERS AUTHORIZED SERVICE CENTER which displays the sign shown at the right. For the location of the one nearest you, see your dealer.



SERVICE INSTRUCTIONS

SPECIFICATIONS

Tubes 5 including 1 rectifier
 Speaker 5 inch PM
 Voice Coil Impedance 3.2 ohms
 Intermediate Frequency 455 KC
 Antenna Single wire or doublet

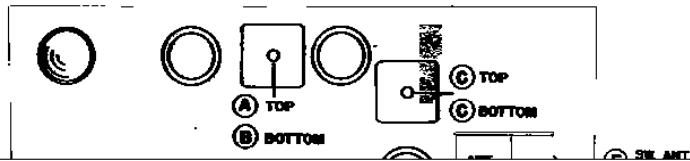

Fig. 4. Top View of Chassis Showing Location of Alignment Adjustments

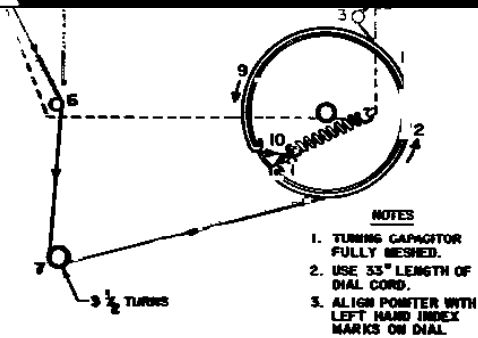

Fig. 3. Dial Cord Stringing Diagram 92C1569-A

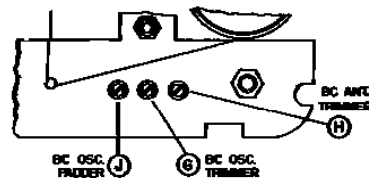

Fig. 5. Front View of Chassis Showing Location of Alignment Adjustments

TUBE AND DIAL LAMP REPLACEMENT - Refer to Fig. 2. for the location of the tubes and dial lamp used in the receiver. It will be necessary to remove the back cover from the cabinet to gain access to the tubes and dial lamp. To prevent damage to the tuning capacitor, set the TUNING control fully counterclockwise before making any replacement. When replacing tubes, check the tube type carefully and replace it with the correct type. The dial lamp and socket can be removed by compressing the side springs on the socket. Replacement of the dial lamp should be made with a 6-6 volt, Mazda #47 (brown bead) pilot lamp or equivalent.

ALIGNMENT PROCEDURE

- Connect output meter across speaker voice coil.
- Set volume control at maximum.
- Use a non-metallic alignment tool.
- Signal generator must have a modulated output and cover 455 KC, 600 KC, 1300 KC and 14 MC.
- Keep the generator output as low as possible to avoid AVC action.
- Refer to Figs. 4 and 5 for location of alignment adjustments.

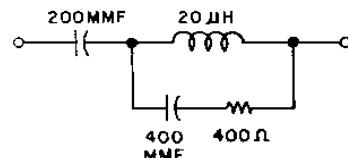

Fig. 6. RTMA Dummy Antenna 92A1544

STEP	SIGNAL GENERATOR CONNECTIONS	SIGNAL GENERATOR FREQUENCY	BAND SWITCH SETTING	RECEIVER DIAL SETTING	ADJUST FOR MAXIMUM OUTPUT
1	High side to stator plates of rear section of tuning capacitor through a .01 mfd. capacitor. Low side to chassis.	455 KC	BROADCAST	1000 KC	A,B, C,D
2	High side to A1 on antenna terminal strip on rear of chassis through a standard RTMA dummy antenna (Fig.6). Low side to chassis. Connect the jumper between A2 and G.	14 MC	SHORTWAVE	14 MC	E,F
3	Same as STEP 2.	1300 KC	BROADCAST	1300 KC	G,H
4	Same as STEP 2.	600 KC	BROADCAST	600 KC	J

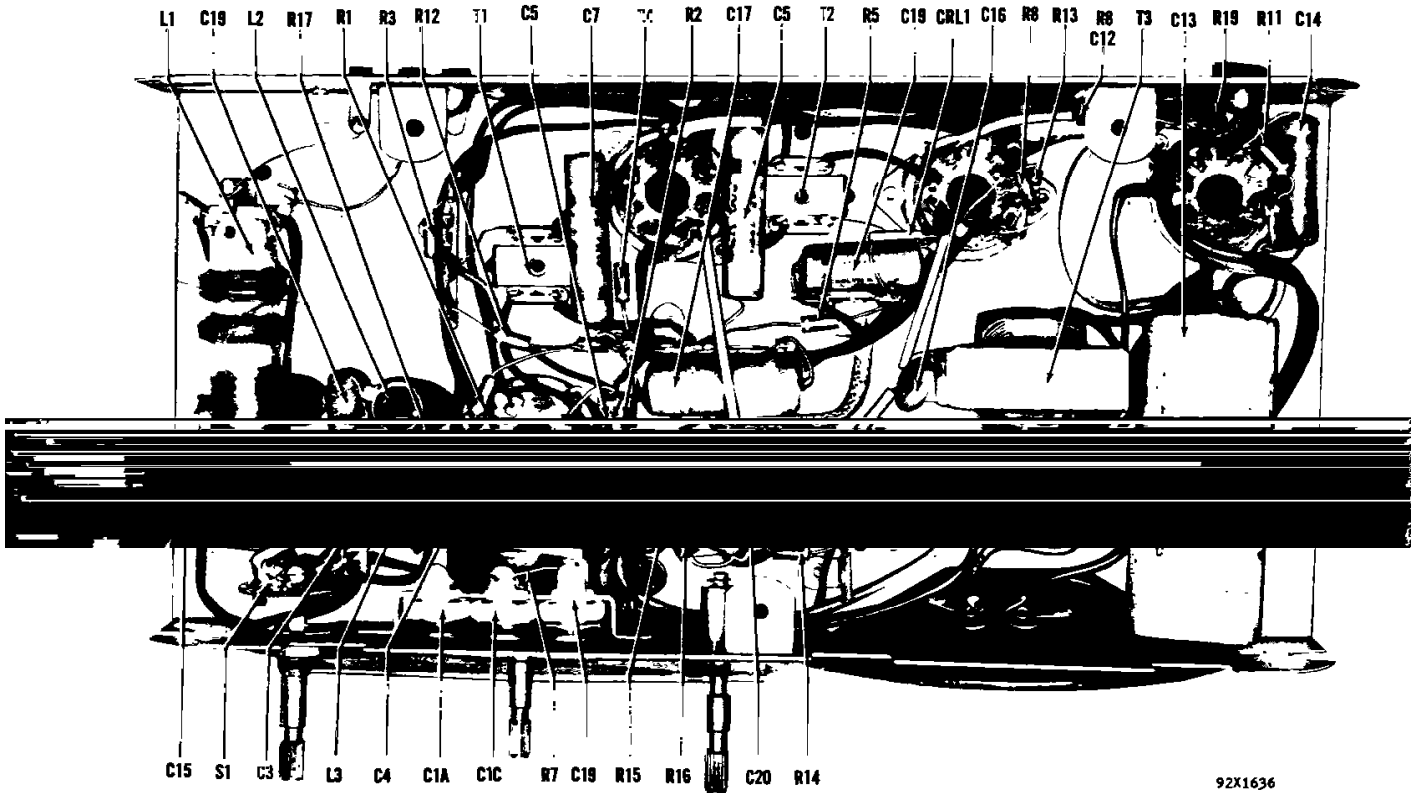

Fig. 7. Bottom View of Chassis Showing Component Location
(Chassis Using Octal Tubes)

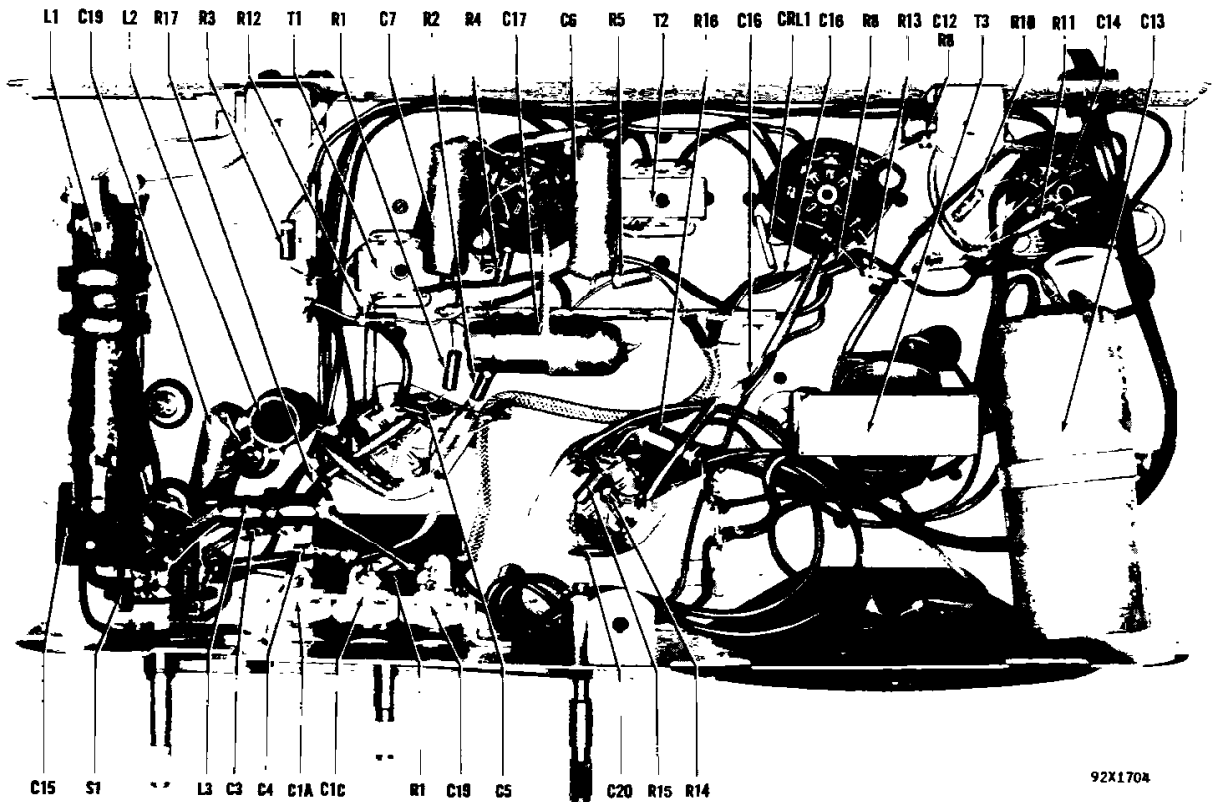
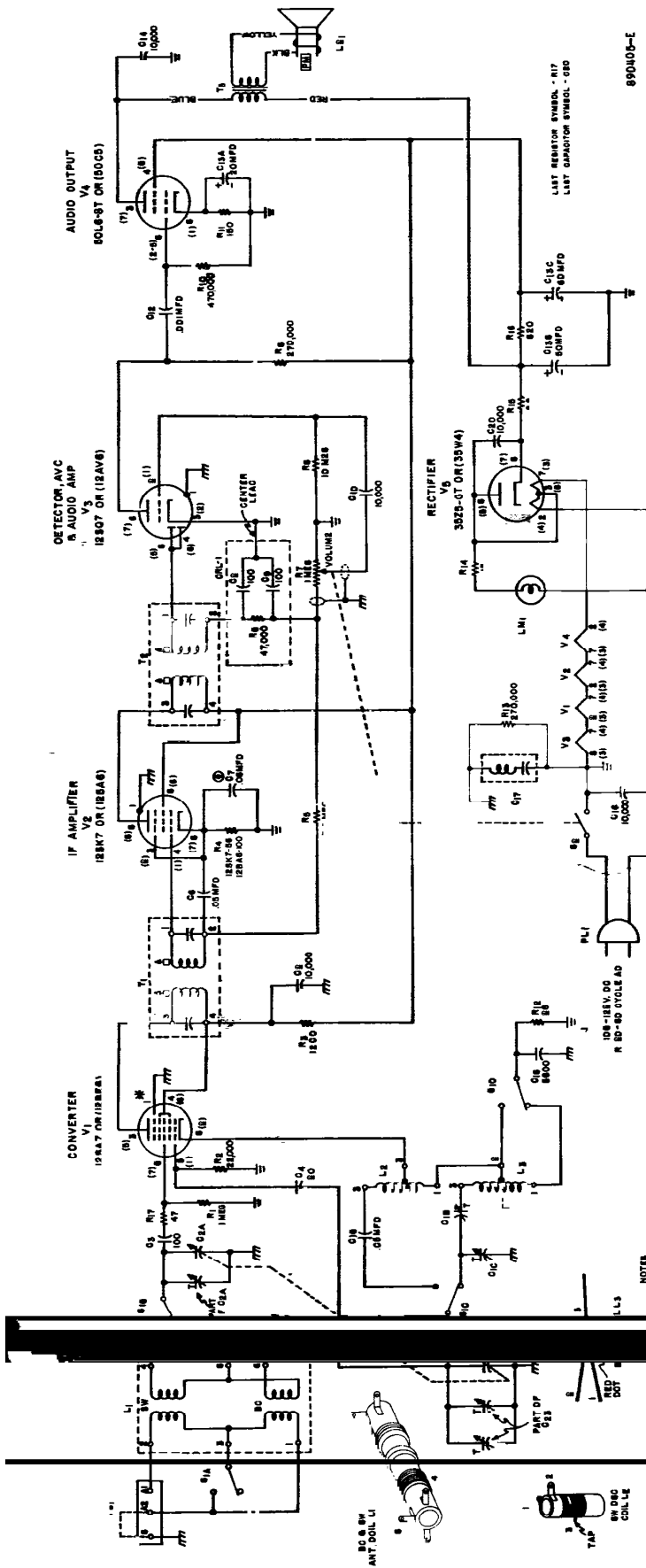

Fig. 8. Bottom View of Chassis Showing Component Location
(Chassis Using Miniature Tubes)

SERVICE PARTS LIST

Schematic Symbol	Description	Hallicrafters Part Number	Schematic Symbol	Description	Hallicrafters Part Number
CAPACITORS					
C-1A,B & C	Trimmer assembly, 3 section	44C408	V-1	12BE6: converter	90X12BE6
C-2A & B	Tuning capacitor, 2 section	48C282	V-2	12BA6: IF amplifier	90X12BA6
C-3	100 mmf. 500 V., ceramic	47X20UJ101K	V-3	12AV6: detector and audio amplifier	90X12AV6
C-4	50 mmf. 500 V., ceramic	47X20UJ500K	V-4	50C5: audio output	90X50C5
C-5,10,14,16,20	10,000 mmf. 450 V., ceramic disc	47A217	V-5	35W4: rectifier	90X35W4
C-6,7,19	.05 mfd. 200 V., tubular paper	46AU503J	MISCELLANEOUS		
C-8,9	100 mmf. (part of diode filter network CRL-1)	-----	Cabinet:		
C-12	.001 mfd. 600 V., tubular paper	46AZ102J	Model 5R30A		116E003
C-13A,B & C	20 mfd. 25 V., 90-60 mfd. 150 V.; electrolytic	45B197	Model 5R31A		116E004
C-15	5600 mmf. 500 V., mica	47X30A562	Model 5R32A		116E005
C-17	Resonant capacitor	46A150	Model 5R33A		116E006
RESISTORS					
R-1	1 megohm 1/2 watt, carbon	23X20X105M	Model 5R34A		116E007
R-2	22,000 ohms 1/2 watt, carbon	23X20X223M	Cabinet back		8C1657
R-3	1200 ohms 1/2 watt, carbon	23X20X122M	Clip, mtg.; for antenna coil L-1		76A879
R-4	56 ohms 1/2 watt, carbon (used with 12SK7)	23X20X560K	Clip, mtg.; for IF transformers T-1 and T-2		76A385
	100 ohms 1/2 watt, carbon (used with 12BA6)	23X20X101K	Clip, mtg.; for oscillator coil L-2		76A868
R-5	2.2 megohms 1/2 watt, carbon	23X20X225M	Dial cord (specify length)		38A001
R-6	47,000 ohms (part of diode filter network CRL-1)		Dial glass		22C349
	VOLUME control, 1 megohm; includes OFF-ON switch S-2	25B965	Dini light assembly; does not include dial lamp		86A011
R-8	10 megohms 1/2 watt, carbon	23X20X106M	Diode filter network (includes R-6, C-8 and C-9)		49A016
R-9,13	270,000 ohms 1/2 watt, carbon	23X20X274M	Escutcheon, Model 5R30A		7D349
R-10	470,000 ohms 1/2 watt, carbon	23X20X474M	Escutcheon, Models 5R31A, 5R32A, 5R33A and 5R34A		7A352
R-11	150 ohms 1/2 watt, carbon	23X20X151K	Grommet, rubber		16A125
R-12	56 ohms 1/2 watt, carbon	23X20X560K	Knob, VOLUME; Model 5R30A		15B477
R-14	15 ohms 1/2 watt, carbon	23X20X150M	Knob, VOLUME; Models		
R-15	22 ohms 1/2 watt, carbon	23X20X220M			
TUBE COMPLEMENT (MINIATURE)					
MISCELLANEOUS					
CAPACITORS					
L-3	Coil, oscillator; BC	51B1495	Model 5R30A		116E003
T-1	Transformer, IF; input	50B524	Model 5R31A		116E004
T-2	Transformer, IF; output	50B525	Model 5R32A		116E005
T-3	Transformer, audio output	55C187	Model 5R33A		116E006
SWITCHES					
S-1A,B,C & D	Switch, rotary; SW-BC	60B472	Model 5R34A		116E007
S-2	Switch, OFF-ON; part of VOLUME control R-7	-----	Line cord and plug		87A078
TUBE COMPLEMENT (OCTAL)					
V-1	12SA7: converter	90X12SA7	LM-1	Lamp, dial; Mazda #47	39A004
V-2	12SK7: IF amplifier	90X12SK7		Lock, line cord; male	76A397-1
V-3	12SQ7: detector and audio amplifier	90X12SQ7		Lock, line cord; female	76A397-2
V-4	50L6GT: audio output	90X50L6GT		Pointer, dial	82A211
V-5	35Z5GT: rectifier	90X35Z5GT	LS-1	Shaft, tuning	74B511
				Socket, tube; miniature (with center shield)	6B402
				Socket, tube; miniature (without center shield)	6B314
				Socket, tube; octal	6A250
				Spring, dial cord	75A012
			TS-1	Speaker, 5 inch PM (refer to part number stamped on speaker)	85C127 or 85C103
				Terminal strip, antenna	88A032



MODELS 5R30A, 5R31A, 5R32A, 5R33A and 5R34A

Property of NIPS RUN 3

VALUES AND TOLERANCE SHOWN ARE NOMINAL AND VARIATIONS MAY BE FOUND. IT IS RECOMMENDED THAT THE VALUE OF ANY REPLACEMENT COMPONENT CORRESPOND TO THE NOMINAL VALUE OF THE PART BEING REPLACED.

NOTES:
 1. SOCKET VIEWS ARE BOTTOM VIEWS.
 2. ALL VOLTAGES ARE MEASURED BETWEEN TUBE SOCKET TERMINALS AND B- (PIN 3 OF TUBE V-3 WITH ZERO TUNING CAPACITOR FULLY WASHED).
 3. LINE VOLTAGE - 117 VOLTS AC.
 4. ALL VOLTAGES ARE DC AND POSITIVE UNLESS OTHERWISE SPECIFIED. ALL VOLTAGES SHOWN AS AC WILL BE DC.
 5. DC VOLTAGES WERE MEASURED WITH A VACUUM TUBE VOLTMETER (VTVM).

Fig. 9. Schematic Diagram

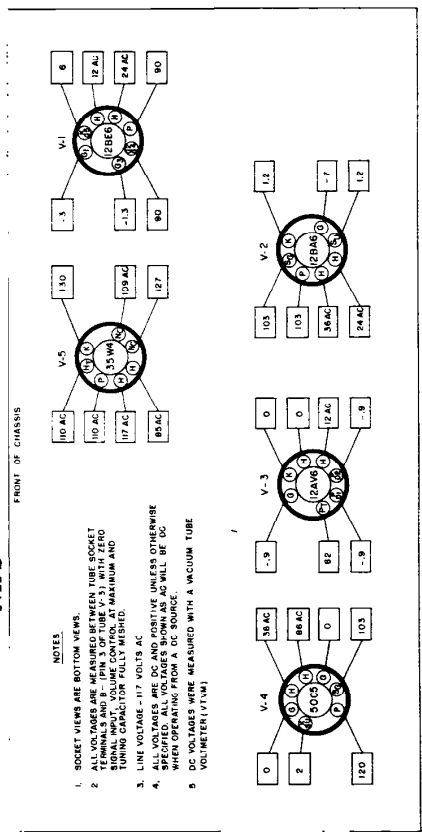

Fig. 11. Tube Socket Voltage Chart for Chassis Using Miniature Tubes

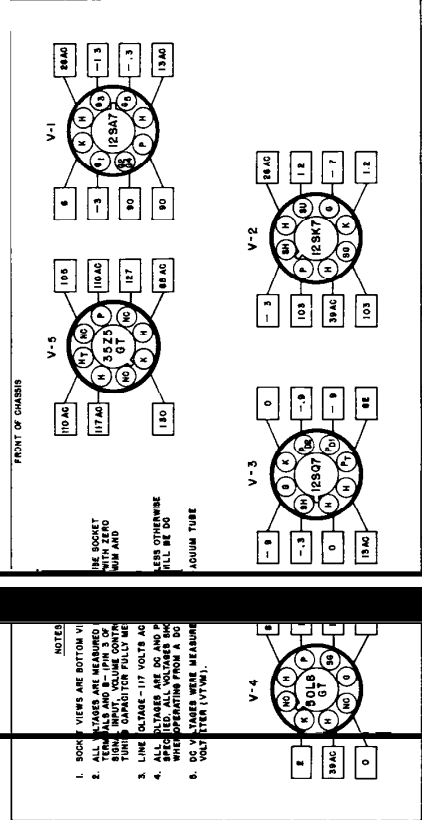

Fig. 10. Tube Socket Voltage Chart for Chassis Using Octal Tubes