

MODEL 1-A SINGLE SIDEBAND RECEIVER -- REFERENCE DATA

OPERATING RANGE: Seven 600 kc tuning ranges cover five "ham" bands:
80M (3.5 - 4.1 mc), 40M (7.0 - 7.6 mc), 20M (14.0 - 14.6 mc),
15M (21.0 - 21.6 mc), 10M (28.0 - 28.6 mc), 10M (28.5 - 29.1 mc),
10M (29.1 - 29.7 mc) - also WWV-10 mc.

DETECTION: Product Detector for SSB, CW, and AM by exalted carrier method.

MAIN DIAL: Dial is marked in 10 kc divisions; frequency can be estimated to 1 or 2 kc. Pointer is movable to make accurate calibrations. Effective scale length is 8.3 inches.

MAIN TUNING: Concentric tuning knobs provide two tuning rates: 4-1/2 turns for 600 kc and 30 turns for 600 kc. Tuning rate is the same for all bands.

STABILITY: High stability VFO unit operates without switching or ganging through same frequency range for all bands. Warm up drift is less than 300 cps after 15 minutes operation. Crystal-controlled, high frequency conversion establishes this same stability for all bands.

SENSITIVITY: Less than 1 uv for 20 db s/n.

ANTENNA ATTENUATOR: 30 db. Switch provided to switch pad in or out.

SELECTIVITY: Multi-section sideband filter provides selectivity as follows:
2.5 kc at 6 db - 8.1 kc at 60 db. Sideband tuning control moves filter response up to 3 kc above or below the fixed carrier.

S METER: Meter calibrated in "S" units to S9 and 20, 40, 60 db over S9. S9 represents approximately 100 uv at the antenna input, "S" units are at approximately 6 db intervals. Properly damped meter movement for steady readings.

AVC: Amplified-delayed AVC. Integrating dual-action time constant circuit gives fast charge, slow discharge for modulation, but fast charge, fast discharge on short pulses. This provides some noise limiter action.

AF RESPONSE: Down approximately 20 db at 65 and 6200 cps
Down approximately 6 db at 200 and 3500 cps

CRYSTAL CALIBRATOR: Provides markers at 100 kc intervals across all bands. Off-on switch is part of ANTENNA TRIMMER control.

POWER CONSUMPTION: 50 watts at 115v - 60 cps

DIMENSIONS: 6-3/4" wide x 11" high x 15" deep

WEIGHT: 18 pounds

NUMBER OF TUBES: Thirteen: 6BZ6 1st RF -- 6BE6 1st mixer --
6BE6 2nd mixer -- 6BY6 3rd converter -- 6BZ6 IF --
12AU7 product detector -- 6BJ8 AVC amplifier and rectifier --
6AB4 crystal oscillator -- 6BQ7A V.F. oscillator --
12BA6 calibrator oscillator -- 12AU7 L.F. oscillator and 1st AF
12AQ5 AF output -- 12X4 rectifier.

FRONT PANEL CONTROLS: Band switch - Main Tuning - Sideband Tuning -
Antenna Trimmer/ 100 kc calibrator - RF Gain/ Standby Switch -
AF Gain/ Power Switch

BACK PANEL CONTROLS AND TERMINALS: S-meter zero adjust - Antenna
Attenuator Switch - SO 239 Antenna connector - Muting connector
External speaker/ phone jack - 4 ohm AF Output/Internal speaker
input.

II. INSTALLATION

- A. POWER - The I-A is designed for operation from 105 - 125 volts, 60 cycles, A-C ONLY and consumes 50 watts. OPERATION FROM LOWER POWER LINE FREQUENCIES OR HIGHER POWER LINE VOLTAGES WILL DAMAGE THE POWER TRANSFORMER AND VOID THE GUARANTEE.

Note: It is not advised that the I-A be used for a mobile receiver. The moisture condensation due to extreme temperature changes will eventually affect the stability of the VFO.

However, if the I-A is used in mobile service, power can be obtained from a 50 watt inverter.

- B. LOUDSPEAKER - A good external speaker is recommended for fixed station use. A specially designed communications speaker has been built into the I-A for portable use. This speaker is connected to the AUDIO IN and GND screw terminals on the back of the receiver. When it is desired to use the built-in speaker, a jumper is placed from the AUDIO IN screw terminal to the AUDIO OUT screw terminal. If it is desired to use an external speaker, this jumper is removed and the external speaker wires connected to the AUDIO OUT and GND screw terminals. The output impedance of the I-A is 4 ohms.
- C. MUTING - NOTE: THE EXTERNAL MUTING SHOULD BE USED IN ALL CASES WHEN THE I-A IS USED WITH A TRANSMITTER.

An RCA phono jack is provided on the back of the receiver for this external muting. This biases the r-f tubes in the I-A to cut off when transmitting and prevents the AVC condenser from charging up which would cause a slow return to receive after transmitting. The switch on the RF GAIN/STANDBY control is in parallel with the MUTE jack and should be pushed in to open the switch and allow the external switch or relay contact to perform this function.

A shielded wire should be soldered into the phono plug in the MUTE jack. The hot wire should go to an exciter auxiliary relay contact which is open when transmitting and grounded when receiving. A set of auxiliary contacts on the antenna relay may be used for this purpose by connecting the shield to one contact and the hot wire to the other.

If the I-A is used with a voice controlled exciter, wires should be run from the AUDIO OUT and GND screw terminals to the exciter terminals to which the exciter manufacturer recommends the receiver be connected. This connection is for operation of the antitrip only and there is generally no need for the exciter to break the speaker leads.

When using a phone patch such as the R. L. Drake Model 584, it is not necessary to mute the speaker lead. When the bias muting is connected properly there is no audio at the output terminals. It is only necessary to connect the phone patch in the speaker leads and run a wire to the exciter anti-trip.

D. ANTENNA - The antenna input impedance of the 1-A is 50-75 ohms. It is recommended that the receiver be fed with a coax line which is matched to a resonant antenna either directly or through balun coils or antenna tuner. Feeding the receiver from high impedance line or a non-resonant antenna will result in an apparent loss in sensitivity.

Antenna relay is recommended for use with your receiver and transmitter. This will permit you to use your best antenna on your receiver as well as the transmitter. The use of a separate receiving antenna, a TR switch of usual design, or an unshielded line between the receiver and the antenna relay, will permit a large signal to enter the receiver when you transmit. This will probably not harm the receiver, but it may interfere with the instantaneous restoration of reception after transmitting.

III. OPERATION

A. CONTROLS

1. **BAND SWITCH** - Used to select desired frequency band. Bands covered are: 80M (3.5 - 4.1 mc), 40M (7.0 - 7.6 mc), 20M (14.0 - 14.6 mc), 15M (21.0 - 21.6 mc), 10M (28.0 - 28.6 mc), 10M (28.5 - 29.1 mc), 10M (29.1 - 29.7 mc) - also 9.9 - 10.5 mc for WWV.

2. **MAIN TUNING** - Used to select desired frequency.

(a) The large knob is the fast tuning knob and covers approximately 120 kc per revolution. This knob is normally used only when moving from one part of the band to another.

(b) The small knob is the slow tuning knob and covers approximately 20 kc per revolution. This knob is normally used when tuning a small portion of the band.

(c) The tuning dial is marked in 10 kc divisions and the frequency can be estimated to 1 or 2 kc. NOTE: The dial pointer is movable from the front panel to make accurate calibrations.

3. **SIDEBAND TUNING** - Used to select desired sideband. The white band painted on the knob represents the passband of the receiver. The center line on the front panel represents the fixed reinserted carrier - other divisions are approximately 1 kc each.

(a) For **LOWER SIDEBAND** reception, the right edge of the white band should be set to the center line on the front panel.

(b) For **UPPER SIDEBAND** reception, the left edge of the white band

should be set to the center line on the front panel.

When these settings are made, the receiver should be tuned to "drop an interfering heterodyne off the edge of the passband".

It is not necessary to retune the **MAIN TUNING** when moving the **SIDEBAND TUNING** knob since this is NOT a bfo pitch control. When you adjust this knob, you are actually moving the 50 kc passband about the fixed reinserted carrier frequency.

4. ANTENNA TRIMMER/ 100 KC CALIBRATOR SWITCH -

- (a) Antenna Trimmer - Used to peak antenna circuits in receiver. This control should be adjusted for maximum signal strength of the incoming signals or adjusted for maximum noise when no signal is present. NOTE: The antenna trimmer on the 1-A tunes much sharper than on most receivers. It must be set very carefully to obtain best reception and least interference.
- (b) 100 KC Calibrator Switch - With the pointer on the ANTENNA TRIMMER knob set anywhere in the top half of the rotation, the calibrator is OFF. With the pointer set anywhere in the bottom half of the rotation, the calibrator is ON.

5. RF GAIN/STANDBY SWITCH -

- (a) RF GAIN - Limits the sensitivity of the receiver at no signal. This control is normally set fully clockwise. However, background noise between transmissions can be reduced by backing off this control slightly. The position of the RF GAIN control does not affect the audio volume, AVC action, or S-meter reading so long as the control setting is such that the incoming signal still moves the S-meter. Backing off this control beyond the point where the incoming signal will move the S-meter serves NO useful purpose and may cause a blast of noise when recovering from the muted condition. This is due to charging the AVC through the high impedance RF GAIN control rather than the low impedance AVC circuit.

THE RF GAIN IS NOT A VOLUME CONTROL. USE THE AF GAIN WHEN IT IS NECESSARY TO CONTROL THE VOLUME.

- (b) STANDBY SWITCH - Mutes the receiver. Pull knob outward for receive and push inward for standby.

When using external muting terminal on the back of the receiver, the knob should be pushed inward.

The muting can be disabled at any time by pulling the knob outward. This allows you to monitor your own signal.

6. AF GAIN/POWER SWITCH -

- (a) AF GAIN - Adjusts the audio gain. (Volume control).
- (b) POWER SWITCH - Turns receiver A-C power on and off. Pull outward to turn receiver on and push inward to turn off.

7. ANTENNA TRIMMER - (On back of receiver) - Used to adjust S-meter to
wise and the antenna disconnected.

8. ANT. SW. (ANTENNA SWITCH)- (On back of receiver) - Controls an L pad of approximately 30 db in the antenna circuit. The pad will prevent strong signals not in the passband from cross-modulating with the signal being received. This switch should be kept in the down position (marked NORM) except for conditions of extremely strong signals found on the lower frequencies on large antennas or when another amateur station close by is operating on the same band.

B. SINGLE SIDEBAND RECEPTION -

1. Pull AF GAIN/POWER knob outward.
2. Pull RF GAIN/STANDBY knob outward.
3. Turn RF GAIN knob fully clockwise.
4. Turn AF GAIN knob about 1/4 turn clockwise (9 o'clock).
5. Set the BAND SWITCH to the desired frequency range.
6. Rotate the MAIN TUNING knob until the desired signal is located.
7. Set SIDEBAND TUNING for sideband being transmitted.
8. Adjust ANTENNA TRIMMER for maximum signal strength.
9. Set the AF GAIN control to produce the desired listening level.

C. AM RECEPTION - Same as SSB reception above. Select sideband more free of interference. It is sometimes desirable to set the SIDEBAND TUNING more off center to reduce the carrier to an inaudible level. Since the sideband filter can be set to attenuate the carrier and one sideband of the AM signal, the incoming AM signal is converted into a SSB signal. There is no longer the necessity of tuning the AM signal right "on the nose" to have it sound right as had to be done in the past with regular communications receivers when receiving AM with the bfo turned on.

Since the AM signal is now a SSB signal as far as the receiver is concerned, its sideband signal strength (instead of the carrier strength) controls the AVC the same way as a SSB signal would.

D. DOUBLE SIDEBAND-SUPPRESSED CARRIER RECEPTION - Same as SSB reception above. Select sideband more free of interference.

E. CW RECEPTION - Same as SSB reception. Rotate sideband tuning for minimum interference.

IV. CIRCUIT THEORY

A. GENERAL - Explanation of Block Diagram

The signal enters at the left from the antenna and is sharply peaked by high Q antenna coils and trimmer capacitor which is a front panel control.

A 6BZ6 is used as a low noise RF amplifier.

The RF amplifier plate circuit coils are fixed tuned to the center of each band.

The first mixer, a 6BE6, is separately excited from the crystal controlled oscillator (6AB4).

The 2.9-3.5 mc I.F. coupler is a double-tuned, overcoupled transformer with a bandwidth of 600 kc.

The valley or dip in the middle of this overcoupled response is filled in by the response of the RF coils tuned to the middle of the band.

The second mixer, also a 6BE6, is excited with the stable VFO unit (6BQ7-A).

The VFO tunes the range of frequencies between 4.0 and 4.6 mc.

By subtracting the 1st I.F. range from the VFO range, you come out with a fixed frequency of 1100 kc, the frequency of the 2nd I.F.

The third mixer, a 6BY6, is self-excited from its oscillator section which is running at 1050 kc. The 1050 kc oscillator is mixed with the 1100 kc I.F. and the resultant output, 50 kc, passes through the SIDEBAND FILTER.

The passband of this filter can be moved up to 3 kc above or below the fixed 50 kc BFO frequency.



I.F. amplifier.

The 12AU7 product detector is followed by a 3 kc low pass filter which removes the 50 kc BFO voltage from the audio and adds to the selectivity by restricting the high audio frequencies.

The AF amplifier (1/2 12AU7) and output (12AQ5) stages provide the necessary audio gain and output power. Inverse feedback and coupling circuits have been selected to give flat, distortion-free response and to restrict the high and low frequency response.

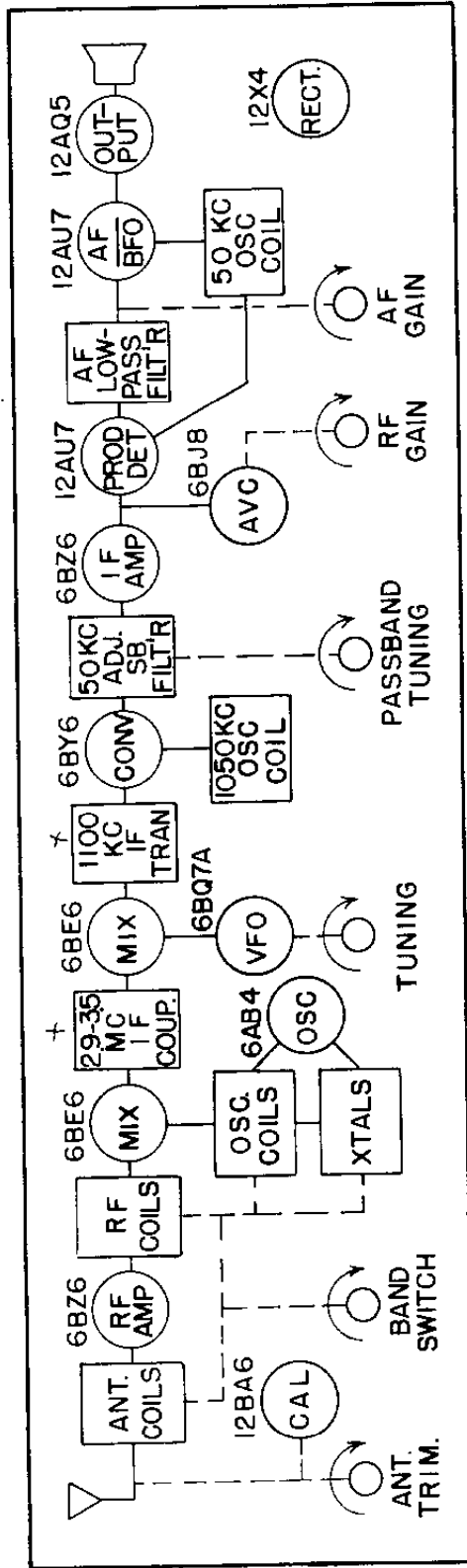

BLOCK DIAGRAM—MODEL I-A SIDEBAND RECEIVER

B. ELECTRICAL DESCRIPTION

- I. RF AMPLIFIER - (V-1) This stage is in the circuit on all bands. It is a conventional circuit utilizing a 6BZ6 tube, a semi-remote cutoff pentode.

The 6BZ6 was chosen because of its low noise, high gain, and low cross-modulation. The plate current of this tube is used to drive the S-meter.

The signal grid is connected to the antenna coils which were designed for 50-75 ohm unbalanced input. The ANTENNA TRIMMER is connected across the antenna coil secondary and tunes it to resonance.

The signal grid is returned to the AVC line through a 2.2 megohm resistor to prevent possible damage to the tube through grid current.

The gain of the RF amplifier is sufficient to amplify the front end noise to a level which will blanket the noise from mixers further along in the circuit. This means that full advantage is taken of the low noise RF stage.

The plate circuit is tuned to resonance with the RF coils. They are tuned to the center of each band. Since the 2.9 - 3.5 mc coupler has a peak on each end of the band and a dip or valley in the middle, peaking the RF coils in the middle of the band fills the "valley" and produces a flat response curve across the whole band.

-
-
2. 1st MIXER - (V-2) - This stage utilizes a 6BE6 tube. The signal

is returned through a 68,000 ohm resistor to the AVC line.

This stage used some cathode bias in the form of a cathode resistor to increase the bias and reduce the gain to prevent cross-modulation from strong signals.

The injection grid is separately excited from V-3, the crystal-controlled oscillator.

The plate circuit is coupled to the 2nd mixer through the 2.9 - 3.5 mc band-passed coupler.

3. CRYSTAL OSCILLATOR - (V-3) - This stage utilizes a 6AB4 tube operating as a grounded grid oscillator with the plate circuit parallel resonant at the crystal overtone frequency that is desired.

The crystal is connected between a low impedance capacity tap of the resonant circuit and the cathode of the tube.

The crystals all operate on overtones except X1 which is on the fundamental. The output from X1 is quite high so extra tuning capacity and resistance load is used to keep the drive down.

X2 is a 3500 kc fundamental crystal but it is operated on its

one crystal.

The output is fed to the mixer from the low impedance point in the circuit so that there is no oscillator pulling.

4. 2nd Mixer - (V-4) - This stage, a 6BE6, is excited from the stable VFO unit. The signal grid is connected to the 2.9-3.5 MC coupler which is returned to the AVC line. Its plate is coupled to the converter tube signal grid through two double tuned I.F. transformers at 1100 mc.
5. VFO - (V-5) - This stage utilizes a 6BQ7A, which was selected for its high "Figure of Merit". That is a large gm to internal capacity ratio. The large gm allows very loose coupling of the tube to the tuned circuit and thereby minimizes its effect on the frequency.

Some cathode degeneration was also added to further isolate the

One half of the tube is used as a buffer amplifier to isolate the VFO from the mixer and to provide low impedance output.

6. 3rd MIXER - (V-6) - A 6BY6 was selected for this stage because of the unusually high conversion gain that it provides.

The signal grid is connected to one of the 1100 kc I.F. transformers which is returned to a fixed bias of - 1.5 volts.

In this converter with its oscillator section running at 1050 kc, the signal is beat down to 50 kc.

The plate is connected to the sideband tuner/filter.

7. **SIDEBAND TUNER/FILTER** - This unit is made up of four resonators. These resonators are identical and are all tuned to the same frequency.

The coupling capacitors are critical in size since they determine the band width and the flatness of the response.

This filter is the electrical equivalent of a mechanical filter. It is designed the same way, using the same formulas.

The resonators are slug tuned and ganged to the sideband tuning control so that the response can be moved up or down in frequency without changing the shape of the passband.

8. **I. F. AMPLIFIER - (V-7)** - This stage utilizes a 6BZ6 and is used to amplify the 50 kc signals to the level required by the product detector. Its signal grid is connected to the Sideband Tuner/Filter and its plate is broadly tuned to resonance by a 50 kc I.F. coil.

9. **AVC, RF GAIN, AND MUTING CIRCUIT** - The 6BJ8 (V-9) triode section is used as an AVC amplifier and low impedance charging tube for the AVC condenser.

There are two separate AVC voltages produced by this circuit. One is applied to the RF and mixer tubes. The second is applied to the I.F. tube only.

The difference in these two AVC supplies is in their attack and release time constants.

AVC-1 charges C-66 through R-45 plus the tube plate resistance in about 20 milliseconds. It discharges through R-46 in one second.

AVC-2 charges C-64 through the tube plate resistance only, and discharges through R-45 in less

On a short pulse, only AVC-2 has time to charge. Its fast action tends to reduce the sound of the noise and its fast release leaves no dead space after the pulse.

So, the AVC system as a whole provides an attack time of about 160 microseconds and a release time of one second.

At the same time, it is unobstructed by noise pulses and actually provides some limiter action.

The RF GAIN control applies a negative voltage in series with AVC to limit the maximum sensitivity of the receiver and provides an equal voltage to delay the start of AVC action. Thus the overall gain of the receiver is not reduced until the RF GAIN is retarded to a point where the S-meter stops kicking upward with signal voltage.

Muting is accomplished by inserting a cutoff voltage at this point. This cutoff voltage is in series with the AVC condenser so that it is not necessary to charge it when muting or to discharge it when the receiver recovers. This makes muting and recovery almost instantaneous.

10. **PRODUCT DETECTOR - (V-8)** - A 12AU7 twin triode is used as a conventional 2-triode product detector. Its signal grid is capacitively coupled to the plate of the I.F. amplifier and its BFO injection grid is connected directly to a low impedance tap on the 50 kc BFO coil to obtain the proper injection voltage.

The output plate is connected to the 3 kc low-pass AF filter.

11. **3 KC LOW-PASS FILTER** - This filter serves three purposes:

- (a) It removes the 50 kc BFO voltage from the audio.
- (b) It adds to the selectivity by restricting the high audio frequencies.
- (c) It reduces harmonic distortion in the audio which is fed to the first audio stage.

12. **BFO - (1/2 of V-10)** - One triode section of a 12AU7 is used as a beat frequency oscillator. It is fixed tuned to 50 kc. A high Q coil and small coupling between the tube and the coil give it high stability.

13. **AF AMPLIFIER - (1/2 of V-10)** - This stage utilizes one-half of a 12AU7 to provide the necessary amplification between the low-pass filter and the output stage.

There are two resistors in series to provide cathode bias and a tap for the negative feedback from the output transformer.

The grid is connected to the arm of the AUDIO GAIN control which is across the low-pass filter output.

The plate is bypassed to ground with a .001 capacitor to limit the high frequency response. It is also capacitively coupled to the grid of the output stage. The size of the coupling capacitor was chosen for correct low frequency cutoff characteristics.

14. **AF OUTPUT AND OUTPUT CONNECTIONS** - This stage utilizes a 12AQ5 tube and is transformer coupled to the speaker. Its grid resistor is returned to a fixed bias supply and the cathode is grounded.

The plate is connected to one side of the primary winding of the output transformer and is also bypassed to the screen B \neq lead to limit the high frequency response. One side of the secondary of the output transformer is grounded and the other side is connected to the tapped cathode resistors in the AF amplifier stage to provide negative feedback to smooth out the response and lower the distortion.

The "hot" side of the secondary is connected to the phones/speaker jack on the rear of the receiver. This is a closed circuit jack which opens the circuit to the AUDIO OUT screw terminal when a plug is inserted. This will shut off the internal speaker if it is being used.

15. **POWER SUPPLY** - A 12X4 tube is utilized as a rectifier tube. The positive output to the filter is 175 volts. One choke, two resistors and 3 electrolytic capacitors are used in the filter network to provide the necessary filtering.

The center tap of the power transformer is connected to ground through a choke. This provides choke input filtering and the voltage across it is filtered with a resistor and condenser network to provide the necessary negative voltages for bias and muting.

C. MECHANICAL CONSIDERATIONS

1. **BAND CHANGE** - This function is controlled by a multi-wafer rotary switch. Band-switching is accomplished by selecting the proper crystal, crystal oscillator plate coil, antenna coil and RF coil.
2. **TUNING** -
 - (a) The main tuning dial is rim driven by the two-speed reduction drive assembly consisting of a train of friction discs.

The amount of driving friction between the dial and the drive assembly is adjustable to prevent slippage due to wear. Loosen the nut at the top mounting screw. Pivot the whole drive assembly toward or away from the dial to adjust the "bite" and then tighten the nut.

(b) Pointer - The dial pointer is adjustable and can be set by sliding the tab under the top front edge of the cabinet.

3. Meter and Dial Lighting - The dial scale is indirectly illuminated from light reflected from the meter face.

The meter is illuminated by two dial bulbs located in either side of the meter mounting frame.

The S-meter scale and the main dial scale are in close proximity so that they may be read at the same time.

4. Internal Speaker - A specially designed communications speaker has been built into the 1-A and it will be found to be superior to an ordinary speaker for speech frequencies.

5. Chassis Construction and Case - The chassis is engineered for ruggedness and yet it is light in weight. Frequency sensitive units which may cause mechanical instability are self-contained sub-assemblies which are rugged themselves and do not depend on the chassis for rigidity.

The uniquely shaped cabinet was designed to occupy a minimum of desk space. It is the same height and depth as the usual receiver, but is less than half as wide. It fits nicely beside the older general purpose receiver which can be kept for AM or short wave listening. The over-all dimensions are 6-3/4" wide, 11" high and 15" deep.

V. MAINTENANCE

We will check and factory align your 1-A for a nominal fee of \$5.00 plus transportation charges if the set has not been tampered with. If repairs are necessary, we will advise you of cost before proceeding with the work. Sets that have been tampered with or misaligned will be repaired on a time and material basis.

A. REMOVING SET FROM CABINET

1. Remove two screws on each side near the rear of cabinet.
2. Pull receiver chassis out back of cabinet.

Note: (a) The knobs do not have to be removed.

- ### B. TUBE REPLACEMENT - In general, most trouble encountered in radio equipment is due to tube failure rather than component failure. The 1-A has been designed so that its tubes may be changed without need for realignment. It is best to not rely too heavily upon tube checkers. The best check is direct substitution of the tube or tubes in question.

C. ALIGNMENT PROCEDURE

WARNING: DUE TO THE BANDPASSED CIRCUITS EMPLOYED IN THIS RECEIVER, ALIGNMENT SHOULD ONLY BE DONE BY A COMPETENT SERVICEMAN WHO HAS THE PROPER TEST EQUIPMENT. UNDER NO CIRCUMSTANCES SHOULD THE ADJUSTMENT SCREWS BE SIMPLY "PEAKED UP" ON NOISE; THIS WILL RESULT IN COMPLETE MISALIGNMENT OF THE OVERCOUPLED CIRCUITS.

1. ALIGNMENT OF CONVERSION OSCILLATORS - A general coverage receiver equipped with a 100 kc crystal calibrator may be used to align the conversion oscillators as follows:
 - (a) Tune general coverage receiver to 600 kc and turn on calibrator. Couple the antenna post of the general coverage receiver to the grid lead of V-8 (pin 7) by bringing the wire into close proximity of the grid lead. Adjust slug on bottom of T-6 for zero beat of the 12th harmonic of the 50 kc oscillator with calibrator. Check at 700 kc to make sure you were hearing the right harmonic.

- (b) Tune general coverage receiver to 2100 kc and turn on calibrator. Couple antenna post of general coverage receiver to grid lead of V-6 (pin 1) by bringing the wire into close proximity of the grid lead. Adjust slug on bottom of T-4 for zero beat of 2nd harmonic of the 1050 kc oscillator with calibrator.

2. ALIGNMENT OF CRYSTAL OSCILLATOR

The S-meter may be used to indicate proper adjustment of the crystal oscillator. The tuning of the crystal oscillator affects the B \neq voltages which in turn upsets the balance of the S-meter circuit at zero. This peculiarity allows the crystal oscillator to be adjusted using the minimum reading of the S-meter as an indicator.

- (a) With no antenna on the receiver, turn the band switch to the band which is to be aligned.
- (b) Adjust slug in L-3 coil for that band (check switch contacts), for minimum S-meter reading (lowest point of a sharp dip). This will be only a very small change but it is enough for proper adjustment of the crystal oscillator. Do not use a signal for this adjustment. The null is in the S-meter reading with no signal. Adjust the 10 meter coil on the lowest 10 meter range.

3. ALIGNMENT OF 1100 KC I.F. TRANSFORMERS

- (a) Set the SIDEBAND TUNING knob to the center of its range.
- (b) Tune a steady signal such as a 100 kc calibrator or signal generator to zero beat.
- (c) Adjust top and bottom slugs of T-2 and T-3 for maximum S-meter reading.

4. CHECKING THE 2.9 - 3.5 MC COUPLER ALIGNMENT

- (a) Remove antenna. Turn RF GAIN and AF GAIN controls fully clockwise.
- (b) Turn band switch to 1st 10 meter band and set dial to 28.3.
- (c) Adjust antenna trimmer for maximum noise.
- (d) Rotate dial toward each end of the band. Notice the position of the noise peaks at each end of the band.

If the two peaks are 400 to 450 kc apart but not located equally from each end of the band, a minor adjustment of the top screw only of T-1 will bring the coupler into proper alignment. If, in making the adjustment, the peaks become more than 450 kc apart, complete alignment of the coupler will be necessary as described below.

5. ALIGNMENT OF 2.9 - 3.5 MC COUPLER

- (a) Connect a 3200 kc generator from ground to pin 7 of V-4 through a 0.5 mmf capacitor.
- (b) Set SIDERAND TUNING to center.

- (c) Adjust top screw of T-1 for maximum S-meter reading.
- (g) Remove jumper from transformer.
- (h) Adjust bottom screw of T-1 for minimum S-meter reading.
- (i) Repeat steps (d) through (h).
- (j) Remove signal generator and 0.5 mmf capacitor.
- (k) Repeat checks in section 4 above.

6. RF ALIGNMENT

- (a) Set dial to 3800 kc. Do not move dial for the rest of this adjustment procedure.
- (b) At each position of band switch, peak the proper L-2 coil for that band for maximum noise (no adjustment on WWV position).

7. VFO CALIBRATION

In normal use, the VFO calibration should not change with time.

- (b) Couple 100 kc calibrator into antenna connector.
- (c) Turn BAND SWITCH to 80 meters.
- (d) Zero beat the calibrator signal at a 100 kc point.
- (e) Loosen set screws in dial hub and turn the dial (not shaft) with MAIN TUNING knob to bring 100 kc point to the line printed on the S-meter to S-9.
- (f) Repeat at other 100 kc points and adjust for best compromise at all points.

8. SIDEBAND TUNING CONTROL ADJUSTMENTS

WARNING: THE SIDEBAND TUNER IS FACTORY ALIGNED AND NO ATTEMPT SHOULD BE MADE TO ADJUST THE SLUGS. THEY ARE ALIGNED IN PRODUCTION AND SOLDERED IN PLACE USING SPECIAL TEST EQUIPMENT NOT AVAILABLE COMMERCIALY.

- (a) Before checking the sideband tuner adjustment, be sure the 50 kc oscillator is exactly on frequency. See paragraph 1 - (a) of this section.
- (b) Turn SIDEBAND TUNING knob each direction from center while listening to noise. The highest pitch of the noise reached in each direction should be the same. If not, adjust the screw on the back of the SIDEBAND TUNER so that the noise sounds the same pitch at each extreme.
- (c) Loosen the set screw on the SIDEBAND TUNING knob and adjust its position so the noise is the same pitch on each sideband at the normal setting.

9. S-METER SENSITIVITY

- (a) Connect 50 ohm output of microvolt calibrated signal generator to antenna connector on the 1-A and tune generator to center of any band.
- (b) Peak MAIN TUNING on generator signal and peak ANTENNA TRIMMER.
- (c) Set output of signal generator for 100 microvolts and adjust METER SENS. pot inside receiver for S-9 indication on the S-meter.

An approximate setting of the S-meter sensitivity adjustment may be accomplished without a signal generator by setting it for an S-meter reading of 60 db over S-9 with the RF GAIN control fully counter-clockwise.

10. CRYSTAL CALIBRATOR

To set crystal calibrator exactly on frequency:

- (a) Set BAND SWITCH to WWV position.
- (b) Tune in WWV at mark on MAIN TUNING DIAL. Carefully zero beat the WWV carrier.
- (c) Rotate ANTENNA TRIMMER knob into lower half of rotation to turn on calibrator.
- (d) Adjust screw on calibrator trimmer capacitor to zero beat also. (Screw is accessible with a small screw driver through perforations in case. It is not necessary to remove receiver from the case.)

D. TROUBLE SHOOTING

The resistance and voltage tables are an invaluable aid in trouble shooting. When making these measurements, bear in mind that they may vary somewhat due to tolerance differences in the components.

TUBE	TYPE	PIN NUMBER								
		1	2	3	4	5	6	7	8	9
V-1	6BZ6	-1.20*	0	0	6.3 ac	140	114	0	--	--
V-2	6BE6	0	1.05	12.6ac	6.3 ac	140	44	-1.25*	--	--
V-3	6AB4	97	--	6.3 ac	0	--	-2.1* approx.	1.30* approx.	--	--
V-4	6BE6	-4.8* approx.	0	6.3 ac	12.6 ac	140	45.5	-1.25*	--	--
V-5	6BQ7A	112	-.82*	3.6*	0	6.3 ac	112	-1.25*	4.8*	0
V-6	6BY6	-3.8* approx.	.78*	6.3*ac	0	140	48 67	-1.50*	--	--
V-7	6BZ6	-1.25*	0	6.3 ac	0	155	111	0	--	--
V-8	12AU7	140	0	4.65	6.3 ac	6.3 ac	73.5	0	4.65	12.6 ac
V-9	6BJ8	-15	-1.25*	0	12.6ac	6.3 ac	-1.25*	108	-4.5	0
V-10	12AU7	68	-8.5* approx.	3.5	0	12.6 ac	41	0	1.4	6.3 ac
V-11	12AQ5	-11*	0	12.6 ac	0	170	155	-11*	0	--
V-12	12X4	250 ac	--	0	12.6 ac	0	250 ac	173	--	--
V-13	12BA6	-30* approx.	0	0	12.6 ac	21	50	0	--	--

NOTE: D-C measurements taken with 20,000 ohm per volt meter unless otherwise noted.

A-C Measurements taken with 1,000 ohm per volt meter unless otherwise noted.

Measurements taken with band switch on 15 meters, STANDBY switch on receive, RF GAIN fully clockwise, AF GAIN fully counterclockwise, and antenna disconnected. Set MAIN TUNING dial to 21.3 mc. Line voltage should be 115v 60 cps.

* This measurement taken with a vacuum tube voltmeter. (11 megohms input impedance.)

VOLTAGE TABLE

TUBE TYPE	PIN NUMBER		
	1	2	3
V-1	4.4-M	0	0
V-2	18-K	330	.1
V-3	inf.	--	4
V-4	18-K	0	1
V-5	inf.	150-K	8
V-6	22-K	150	1
V-7	2.2-M	0	1
V-8	inf.	150-K	8
V-9	33-K	2.2-M	0
V-10	inf.	150-K	1
V-11	240-K	0	.
V-12	470	--	0
V-13	680-K	0	0

TUBE TYPE	PIN NUMBER									
	4	5	6	7	8	9	8	7	6	5
V-1	1.8	inf.	inf.	0	--	--	--	--	--	--
V-2	1.8	inf.	inf.	2.2-M	--	--	--	--	--	--
V-3	0	--	150-K	330	--	--	--	--	--	--
V-4	.16	inf.	inf.	2.2-M	--	--	--	--	--	--
V-5	0	1.2	inf.	150-K	1.4-K	0				
V-6	0	inf.	inf.	33-K	--	--	--	--	--	--
V-7	0	inf.	inf.	0	--	--	--	--	--	--
V-8	1.2	4	inf.	.6	820	.16				
V-9	.16	1	2.2-M	inf.	2.3-M	0				
V-10	0	.16	inf.	.4	1.6-K	3				
V-11	0	inf.	inf.	240-K	--	--	--	--	--	--
V-12	.16	--	470	inf.	--	--	--	--	--	--
V-13	.16	inf.	inf.	0	--	--	--	--	--	--

NOTE: Measurements taken with band switch on 15 meters, STANDBY switch on receive, RF GAIN fully clockwise, AF GAIN fully clockwise, antenna disconnected, A-C line disconnected.

M - Megohms K - Kilohms

Most of the readings that are marked inf. may show a few hundred megohms. This is the leakage resistance of the filter capacitor, C-83 (a, b, and c).

SISTANCE TABLE

TROUBLE	CAUSE	CURE
Tubes and dial lights do not light.	Blown fuse	Replace
S-meter fails to read with signal, but reads with RF GAIN control.	V-1, V-2, V-4 or V-9 defective L-4 open	Replace Resolder coil to leads or replace
S-meter reads low	V-1, V-2, V-4 or V-9 defective Antenna attenuator switch in up position Antenna not resonant on band or does not match receiver input impedance.	Replace Throw switch down to remove attenuator Repair, retune or revise antenna system.
Audio weak and/or distorted, but S-meter reads normally.	Normally closed contacts on phone jack not making good connection. V-11 or V-10 defective	Clean contacts Replace
Hum in audio	Filament-cathode short in V-8, V-10 or V-11 C-81 open	Replace Replace
S-meter cannot be zeroed	V-1 defective	Replace
No audio but S-meter reads normally	V-8, V-10 or V-11 defective C-82 shorted C-78 shorted T-7 open or shorted Jumper not connected between AUDIO IN and AUDIO OUT screw term.	Replace Replace Replace Reconnect

<u>TROUBLE</u>	<u>CAUSE</u>	<u>CURE</u>
No S-meter reading and RF GAIN has no effect .	C-81 shorted	Replace
S-meter against pin on right side and no signals can be heard .	Muting switch open	Replace
No signals can be heard but receiver noise still heard .	V-1 , V-2 , V-3 , V-4 , V-5 or V-6 defective .	Replace
Set dead but tubes and pilot bulbs lighted .	V-12 defective C-83 shorted	Replace Replace
Tuning dial reads off frequency .	Dial pointer not set correctly	Reset dial pointer

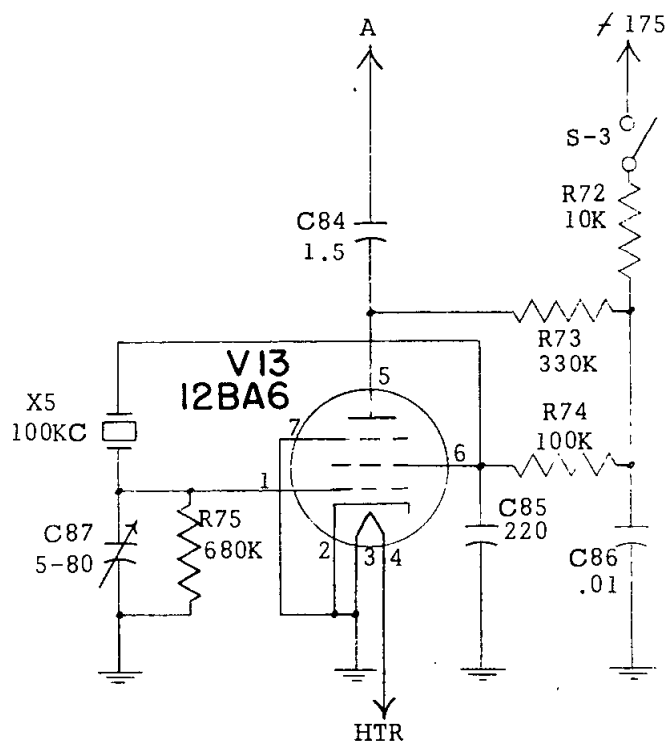

CRYSTAL CALIBRATOR
SCHEMATIC DIAGRAM

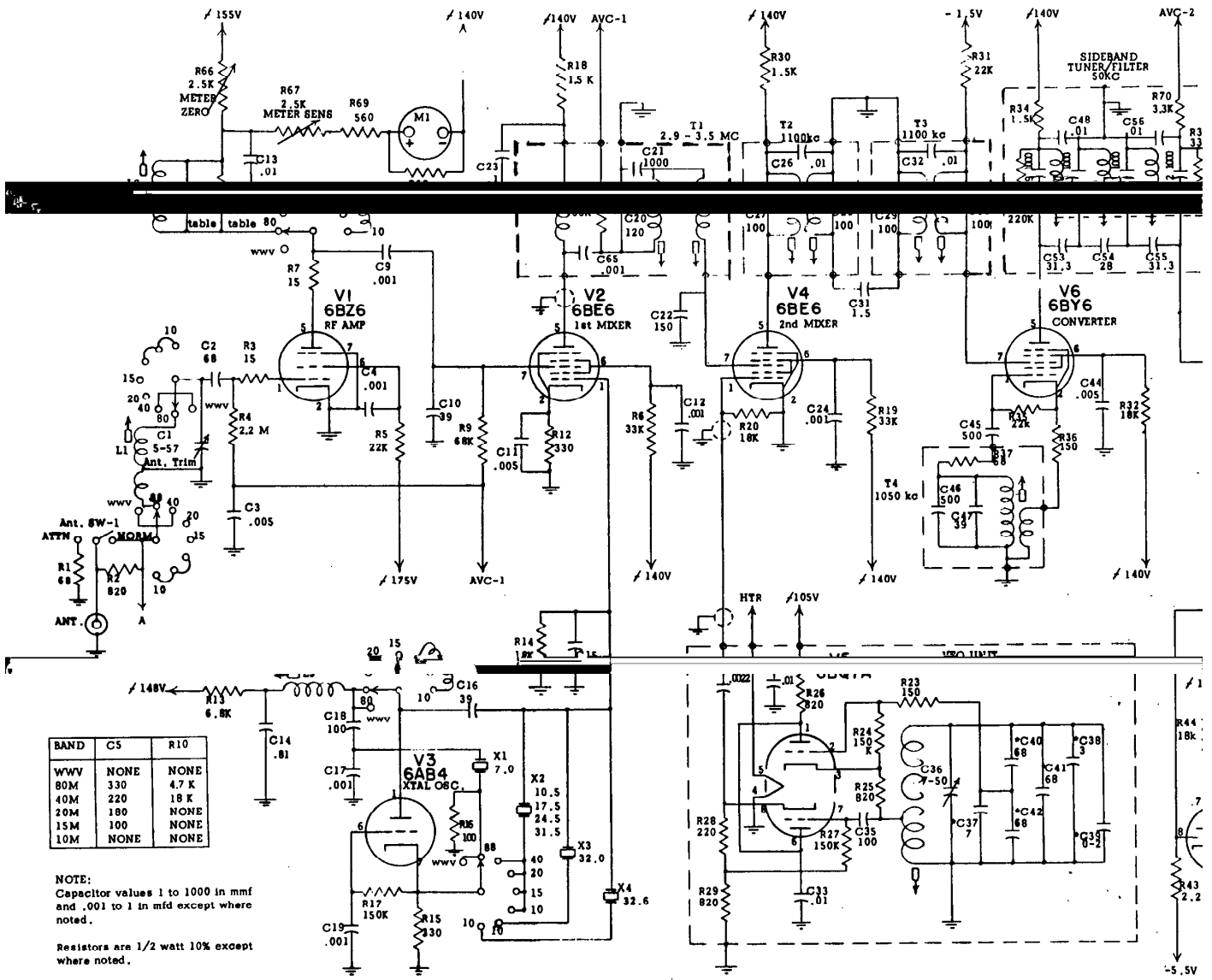

BAND	C5	R10
WWV	NONE	NONE
80M	330	4.7 K
40M	220	18 K
20M	180	NONE
15M	100	NONE
10M	NONE	NONE

NOTE:
Capacitor values 1 to 1000 in mmf and .001 to 1 in mfd except where noted.

Resistors are 1/2 watt 10% except where noted.

*Value selected in production.

SC
CIF

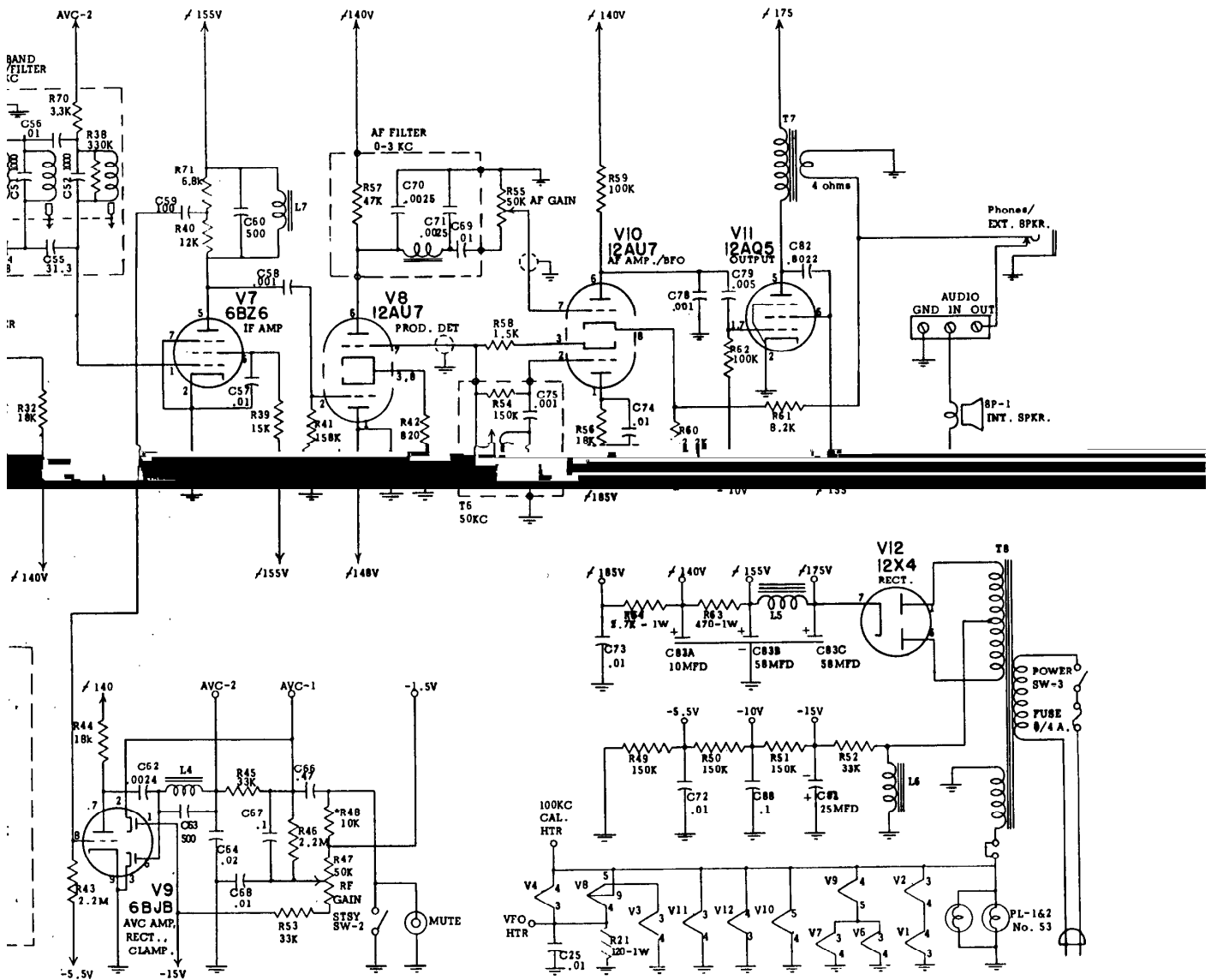

SCHEMATIC DIAGRAM—MODEL I-A SIDEBAND RECEIVER
 CIRCUIT REVISION NO. 2 (STARTING SERIAL NUMBER 453)