

SECTION IV

THEORY OF OPERATION

should
 tional theory
 maintenance
 erational
 th through
 ond, by
 in the
 to single
 sion. Refer-
 m in figure

4-1, the overall schematic diagram in figure 7-1, to the photographs in section VI, and to illustrations supplementing the text.

Throughout the text, reference will be made to various jack, tube, plug and switch terminals. In many instances, this reference is made by following the component symbol by a dash and the terminal number. For instance, J102-7 refers to jack J102, terminal seven, and S101C-3 refers to switch S101C, terminal three.

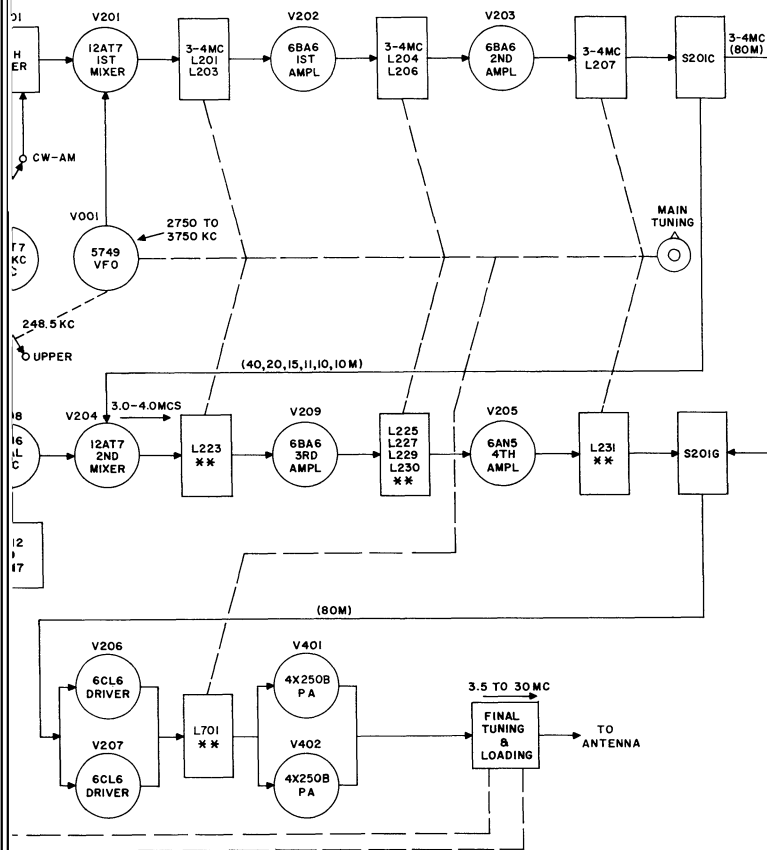

Exciter/Power Amplifier, Block Diagram

Section IV
- 4.2.1.1.

also in-
a
ed in the

NALS.

250-kc
of the
with
ent of the
le to
and
he sideband

NALS.

ing the
e
nd by
e driver
s exciter
ave
sients in

NALS.

it is
atch circuit,
io FSK
carrier shift
h in the
cies of the
in the
unt for

CIRCUITS.

. The
nitter are
r consisting
onventional
upled
d of audio

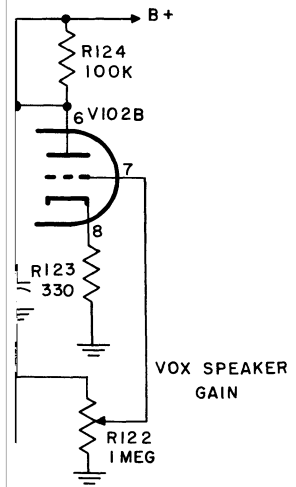

-7
IN

the load components is constant for "fast attack" characteristics. Thus, the capacitor discharges slowly. The VOX audio signal voltage, but, due to the d-c charge tapers off from shutting off the microphone. The cathode of V107A is control grid of relay current of V103B operates the diode load voltage and stores R118 and R119 point where the relay, when audio is spoken on of the signal passes in control R113, is amplified to a plus d-c voltage in V103B grid to overdrive, causing the tube to operate relay K101. When the operating level of R118 and R119, which would be in operation long enough to word of the

B grid to switch S101C-3 calibration procedures, to operating relay K101

103B cathode to the PTT 2, permits use of an b-talk control, instead of its built into the exciter

DED MODULATOR AND FILTER CIRCUITS. Develop- er frequency in the KWS-1 accomplished by a crystal ge, V104. Figure 4-3 is a gram to show only oscillator ulator, FL101 Mechanical out cathode follower stage. ed to study the KWS-1 lopment, modulation and le sideband transmission.

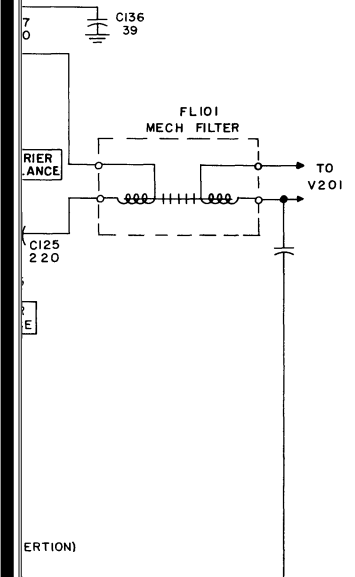

Filter,

C112 pro-
circuits to
riations.
hed sets at
will be
nance and

sofar as the
lio input
causing un-
ate, relative
of the audio
for example,
ng its
2 cathode
to be
the
us, the
debands,
balancing
the modu-
e sideband
e 250 kc
t112 is
s in R150

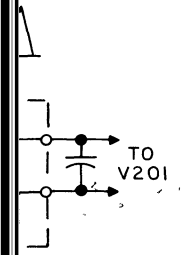

ction IV
2.1.2.

ty or
ired
ers, the
ns a
omposed
C107 and
series
cept the
tor. Low
to attain
he low

he input
ansmits
alloy
disc is
kel-wire
er end
revent
as
phone
for
anical
neto-
one

al
e is
he discs
ding
roduce a
flat top
asses
the flat
FL101
is
kcs.
FL101
the
e, the

CAL SIGNAL
(R OUTPUT)

A.M.
modulator
different

250-kc
circuits.
The carrier
condensers
fed
Antimeter
as desired
is then fed
at side of
per output
control grid.

Output stage
total eight,
with cw
are not
essentially

audio
or are
carrier
and the
carrier

Output of
condenser
per coil,
impedance.
and resistor
V201,
exciter.

The
oscillator
unit, tunable
calibration
consists of
L002. The
connected to
oscillator over-
with L002

Controlled by
voltage and
the circuit
oscillator tubes
used. A
7106 plate

C229 adjust for gain
VFO 225

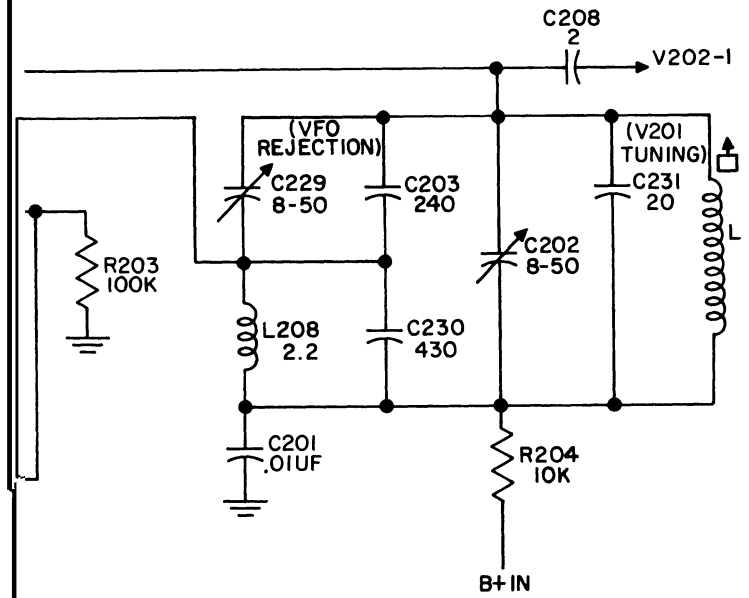

V201, Simplified Schematic Diagram

the
izes
out-
to
t
pli-
in
ter
ach
ne
04,

The ratio of voltage input on pin seven of V201A to that of pin two on V201B is approximately 0.1 volt to 1.5 volts. Thus, the vfo input is considerably stronger than the signal input. This is the reason for the rather complex tuned plate circuit consisting of L201, C231, C202, C203, C229 and C230. L208 is a choke in the V201B plate B plus supply circuit. The purpose of the tuned plate circuit is to reject a strong, undesired frequency component in the V201 output, which is a result of the strong vfo input signal at the V201B grid. The theoretical principle involved is selective feedback rejection. The actual tuned plate circuit consists of C202, C231 and L201, with C202 and L201 adjusted to resonate the circuit at the desired 3 to 4-mc output frequency. C203, C229 and C230 form a capacitive voltage divider. The selected values of C203 and C230 determine the amount of feedback for the undesired vfo frequency component. C229 is adjusted for null of the particular frequency to be rejected. Adjustment procedures will be discussed under Maintenance and Alignment.

and

Thus, by virtue of the heterodyne action in V201, and the selective feedback rejection in the

into
into
50-
on-
ges.
quire
the
enser

OND

08
on
20, 15,

s
nd
is
off

mber

.

n

two
)
for
oint
as-
or
-
nd

acycle
le
quen-
er
cies
s'

is
: 40-

.218,

variable
C256
; he

~~second mixer. Each coil is inductively trimmed at~~

~~The output of V205 is switched through~~

the low frequency end by an iron slug.

S201-G into the driver stages V206 and V207.

(4) THIRD AND FOURTH AMPLIFIERS
 V209 and V205 amplifier stages provide the final amplification and selectivity in the r-f section of the KWS-1 Transmitter.

4.2.1.4. DRIVERS AND POWER AMPLIFIER CIRCUITS.

a. SIGNAL CIRCUITS. Single sideband and ~~AM r-f input signals to the two parallel connected~~

The tuned output circuit of V209, which could also be considered the tuned input circuits of V205, consists of inductances L225, L227, L229, L230 and trimmers C257, C301, C302, C304, C306 and C308. Switch S201E governs the selection of these components for operation on the 40, 20, 15, 11 or 10-meter bands. (See table 4-1.)

6CL6 driver stages passes directly through the E201 and E202 parasitic suppression components to the tube control grids.

Cw keying voltage to the driver stages is fed through R229, E201 and E202 to the 6CL6 control grids.

The tuned plate circuit of V205, also considered the tuned grid input circuits for the 6CL6 drivers, consist of inductances L231, L234, L236 and L237, with capacitors C264, C265, C266, C267, C269 and C272 providing the high frequency trimming. Switching of the tuned circuits is accomplished by S201-F-2, while S201-F-1 opens the V205 cathode circuit when the KWS-1 Transmitter is operating on 80-meters. This prevents undesired signals from leaking into the 80-meter output. R237 thru R243 are loading resistors for all bands except 10 meters high.

The 6CL6 plate circuits are shunt fed through L238 and the parasitic suppression components E203 and E204.

Two test points are provided for the 6CL6 driver stages. One, for the control grids, is taken off the R229-E202 Junction to jack J207. (See figures 5-1 and 7-1.) The other, for the cathode circuit, is taken directly off the 6CL6 cathode and fed into J208.

Driver stage output signals are coupled through C305 and switched over the amateur bands by S201-I to include the correct power amplifier tuned

~~output of the 6CL6 driver input to~~

V205 is in a capacitance neutralization circuit which will be discussed in relation to the driver and power amplifier stages.

grid input circuits for the respective bands. The tuned circuit component combinations for each band are shown in table 4-1.

TABLE 4-1. TUNED CIRCUIT COMPONENTS

METER BAND	2ND MIXER OUTPUT (SWITCH S201D)			3RD AMPL. OUTPUT (SWITCH S201E)			4TH AMPL. OUTPUT (SWITCH S201F-2)			6CL6 DRIVER OUT. (SWITCH S201I)		
	IND.	TRIM.	PAD.	IND.	TRIM.	PAD.	IND.	TRIM.	PAD.	IND.	TRIM.	PAD.

3

of
e
y.
e
s.
-
is
ck
l-

IV
4.

to
e
d
L

the
e
ross
id
ms,
rce
dge

are

ALI-
-to-

se
on
d
is

f the
om
e
to
CL6

by
eries

nk
e

283
5-25

the
ne
r-
).
Utilization
and on
ands,
73 in
ments
These
of
4-14.
anner
re.

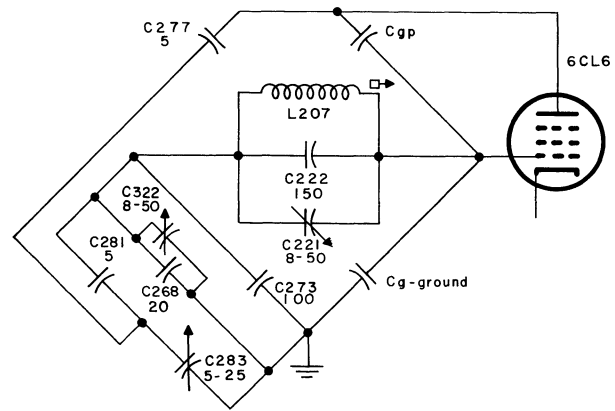
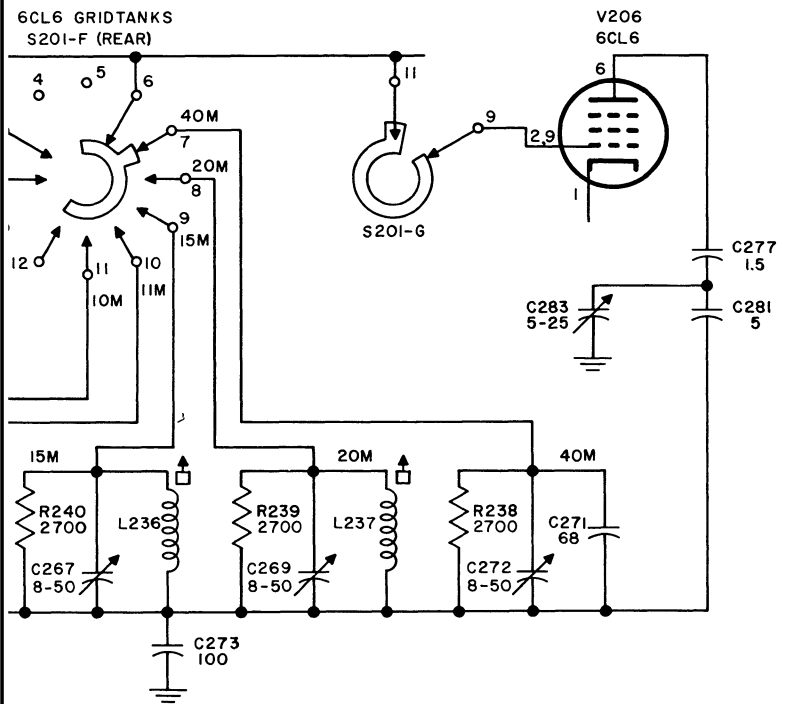

Figure 4-12. 6CL6 Driver Grid-to-Plate Neutralization Bridge Diagram (80 Meters)

EU-
In
rom
, which
. The
osed
d C298
f the

chs
(see
unted
50B.

c. RECEIVER INJECTION. (See figure 7-1).
J201 is connected to the 6CL6 plate circuit to provide receiver injection during calibration procedures. The receiver can be connected to J201 through a "T" fitting in the coaxial line going to the receiving antenna. During calibration, all sections of the KWS-1 Transmitter are turned ON, except the power amplifier. Thus the calibration signal may be heard by the operator to assist in making the proper adjustments. During power amplifier neutralization adjustments, the receiver is connected to J201, and



Neutralization Circuits, (40, 20, 15, 11 and 10 Meters), Schematic Diagram

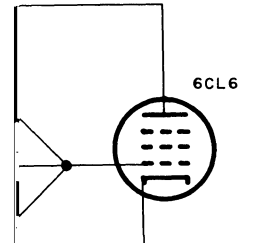

gr

er Grid-to-Plate
ge Diagram
(10 Meters)

and C324, R247. The
y very narrow pulses
however, they are so
fects are caused.
the power amplifier

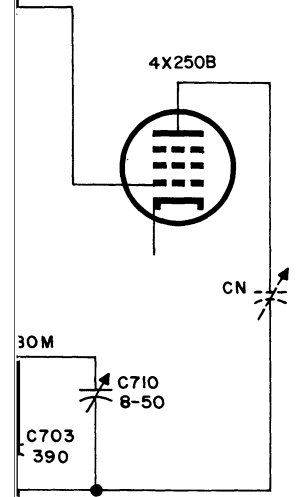

uits,

ON. The power ampli-
measured when the switch
inals 3 and 9. This
ce R705 across meter
terminal 3 is connected
n grid circuit through
and choke L405. Switch
ck J103-8 through the
and nine. J103-8 is con-
ver Supply. This meter
NE-OPERATE switch
ow in paragraph 4. 2. 1. 7.

le ALC d-c control
V202 and V203 through
(See figure 4-17.) The
ough MULTIMETER
cathode to the screen
nose of the meter
to measure the
Control voltage in

meter can register
following points should

meter connection pro-
m the R210-R209 divider.

ion to R206 provides a
age in V202 cathode
control voltage applied

aracteristics of V202
voltage equivalent to

if a curve was plotted
age due to the ALC
duplicate a curve
in gain for V202 due
control grid. There-
position is calibrated

circuit are equivalent to
Collins 75A amateur

Measurement of the
current is accomplished
bs are on switch termi-
shunts the five-ohm
h meter terminals 1

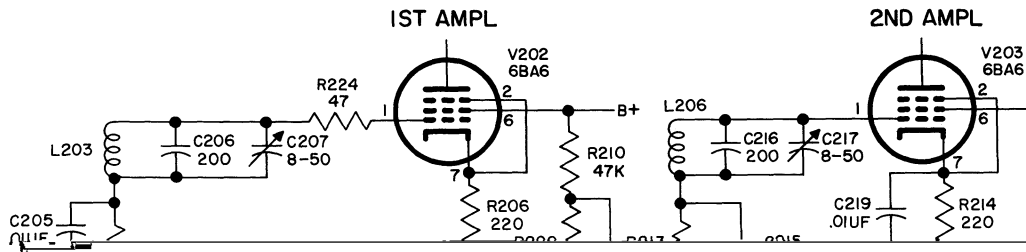

low
-11 on the
poly goes

the
01C-12,
s
ove the

through a
138 and
on of R138
stages is
39 and
al wave
ing voltage
C299 and
:01 and E202,

action is
and R136.
through
filter output
. C127
circuit.

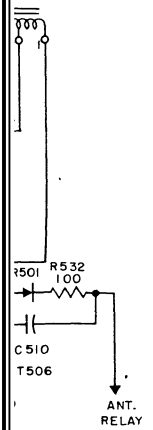

tion IV
2.2.3.

7509,
mary
e a-c

er
recti-
510 to
an
on

' are
ding,
fed
508.
d fed

volts
urnish
gh the
e

an a-c
Connected
ilable
etwork
; cable
ng and
02-19
nto a
,
tenti-
is fed
er
e of

6
02-15
l
utput

off the
4 are

n the
T
oltage
and

3, the voltage and apply at ds. The e across de- above.

screen the bias bias and v through screen ut off the . occur tubes, en fuse.

TO GRID OF V202
FROM ALC RECT. V403
TO PA SCREENS
TO KEYING NETWORK

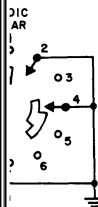

SCREEN SOURCE

High voltage transformer circuit of T503 includes the rectifiers V501 and V502. This output is filtered and fed into a separate coaxial cable off an E501 standoff, directly to the Power Amplifier. Resistor R516 is in the power amplifier plate current meter circuit, and is connected from TB501-4 to J103-14. The PA plate current is measured in the negative side of the power supply 2000-volt output, to keep high voltages off the exciter terminals.

contacts 1 and 3; S101B rear, output of CARRIER LEVEL control is fed through contacts 9 and 7 to provide r-f signal unhindered by balanced modulator; S101C front, contacts 1 and 4 unground VOX circuit so that it may be used to control carrier; S101C rear, contacts 11 and 12 route keying circuit through K101.1 and 2 so that the VOX circuits control turning the carrier on and off.

4.2.3.5. CAL. This position is treated the same as the first CAL position - refer to paragraph 4.2.3.3.

4.2.3.1 GENERAL The carrier control circuits

10

11

12

13

14

15

met front door
making the
the adjustment
turned to position,
the voltmeter.
until a 350-volt
d on the

grid voltage is
BIAS ADJUST
panel until the
front panel reads

l amplifier (V401
coverage from

amount of loading
coverage from 80

is the toggle switch
corner. It lowers
) screen-grid
UNE (down) position.
initial tuning.

the transmitter
res.

rol applies a
vernier tuning
the SIDEBAND
rpose of the DIAL
vernier control
ight adjustment.

he slide-rule
r scale during
as been set,
sary over long

the gain of the

ts the gain of
rcuit. This
inside the exciter
g the top cover,
edge of the front
figures 3-1 and

ADINGS

SCALE INDICATING	TYPICAL READING
ac	6 Volts
dc	<p>Starts at approximately full scale, and decreases as PA is loaded, reaching about 17 ma when proper loading level is obtained.</p> <p>Typical reading depends upon final stage drive.</p>
dc	<p>Typical reading depends upon amount of final stage drive. In AM. and SSB grid current is zero. In CW grid current can be as high as 7 ma.</p>
dc	Approximately 2000 volts, dc.

4.19. INTERNAL SCREWDRIVER ADJUSTMENTS.

a. PA SCREEN VOLTAGE. Adjusts amount of voltage applied to the power amplifier stage screen to 350 volts. This adjusting facility (R511) is located in the power supply cabinet. (See figure and paragraph 4.2.4.6.f.(2) above.)

b. ALC ZERO. This adjustment is inside exciter cabinet top side, to the left of center. Purpose is to adjust the multimeter ALC needle to zero, and is made only when the FILTER switch is ON and final amplifier supply is ON. The EMISSION switch should be in the OFF position.

5. EXTERNAL CONNECTIONS.

5.1. EXCITER/POWER AMPLIFIER CABINET.

Section IV
4.2.5.2.

ection
to the

LTAGE

)
to be made

)
horizontal
e up from
inal
boards,
ing into
) TB503
ich either
nade).
hon
ts are
r of the
elow.

ter V103B
carrier
connects

ugh to
the grid-
ne connects

e normally
Relay K101.
fed through
TB502-14.
mperes
relay coil
tter. The
02-9.

onnect
and 7 of the
the leads

audio
KER gain

(7) J102-13. Provides a ground connection in the Exciter, and a ground for the externally connected cw key, push-to-talk VOX circuits and ant. interlock circuits.

(8) J102-11. This lead (along with the ground lead above) connects to a set of normally open contacts on the antenna relay. This prevents the carrier from coming on before the antenna is connected to the transmitter output.