

Section 3

of operation

ed to the crystal
the plate circuit
. The secondary
ltage to the first
hes a dc return
Dummy load R41
transmitter when

associated cir-
for the product
provide the proper
mechanical filter
response from the
3.650 kc) is used
l Y16 (456.35 kc)
is due to sideband
citor C95 and coil
at 455 kc. Oscil-
49 and coupled by
duct detector tube.
ides marker sig-
ole capacitor C61
t with WWV. The
l to the receiver
s in the generation

The vfo uses fixed
e to produce the
p 2.70135 mc for
865 mc for USB,
r C303, in the
s paralleled by
with diode CR301.
of the circuit de-
voltage impressed
DE switch in the
verse biased and
the frequency-
on will result in
c signal desired.
SB, AM, or CW
ased and switches
network lowering
49865- to 2.69865-
C308 is properly
cy by an amount
crystals Y15 and
e selected without
. The vfo output
of second mixer
cathode follower

ch

s-
ti-
es
rk
rs
he
nd
88
te
r-
nd
a
gc
de
er
d-
er
is

ed
n-
ol
as
es
er
ol
es
er
on
on
11
r.
p-
gc

e-
ed
k,
lio
a
s.
ng
lio
nd
n.
m
ed
he
ad
is
so
in
12
ed

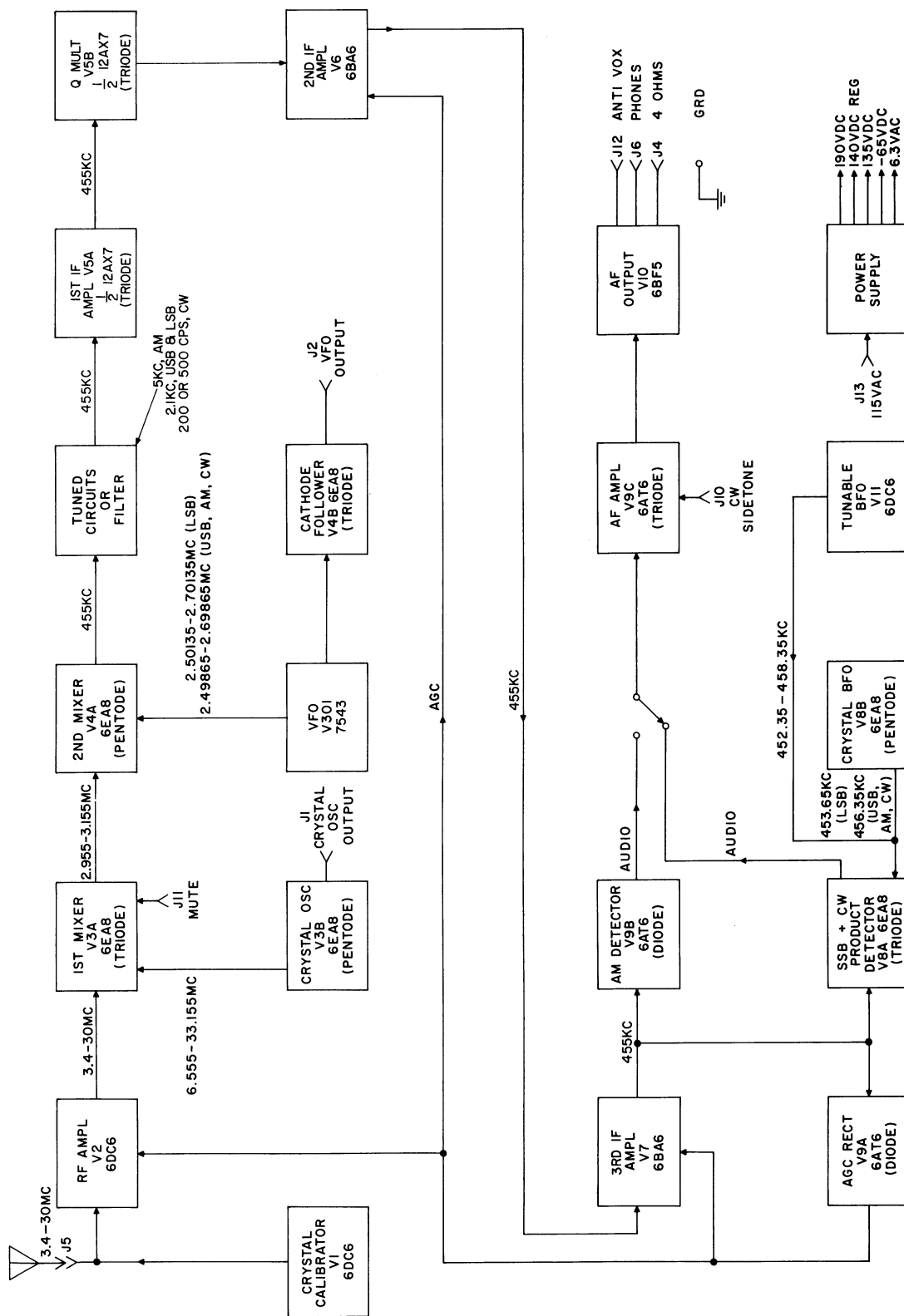

Figure 3-1. Block Diagram

SECTION 3

Principles of Operation

3.8 Power Supply Circuits.

The internal power supply furnishes filament, plate, and bias voltages for the receiver. Three high voltage values are developed consisting of a 190-volt dc unregulated voltage at the positive side of C59B, a 140-volt dc regulated voltage at the cathode of zener diode CR6, and a 135-volt dc unregulated voltage at the positive side of C59A. The high voltage winding of transformer T8; diode CR1, CR2, and CR6; resistor R86; and the filter network consisting of capacitors

C59A, C59B, and C59C, resistor R51, and choke L6 make up the full-wave rectifier system which generates the three high voltage values mentioned above. Bias voltage is obtained by rectifying ac voltage from a voltage divider connected between one leg of the high voltage secondary and ground. The tube heaters and pilot lamps are connected to allow operation from a 6-, 12-, or 24-volt source. Heater, plate, and bias voltages may be furnished by an external source such as a mobile power supply. Figure 7-1 illustrates the proper connections to the power plug for this type of operation.

4

ons

e pins
roded
uation
drops
tube,
imes.
stray
s not
orted
esis-
color.
1 will
icular

n with
k dia-
ouble.
rly in
SB or
should
or AM
uency
to the
ibility
ailed.

ory or
ort of
de to
cy in
ense.
ittent

adings
he vfo
air or
lators
basis
ional,
ake all

GAIN
switch
sition,
AGC
power

VTVM

9
0
220K
3.8
100K
6.3
0
-2.5
5.6K

provide

for peak
necessary
T9, T10,

and output

filter in-
reading.
signal is

of T4 and
reached
with Wal-
st T9 with

alignment,
pin 2 of
passband.
ator, and

C122

V9

V8

FL1
FL2
FL3

T6

T4

V7

T5

T10

R13

V6

C123

R57

V5

M1

L8

77

-017

TION 4
actions
-meter
ECTOR
r peak
FOR to
gnal at
rs for
first,
atten-
ed for
to the
o fre-
ers as
vm to
hassis
nmers
on the
ar 6.6
eading

SHIFT

to beat
urther
t C308

o WWV
trans-

et 100
of the

e cali-
. kc on
is no
artical
stment
lwing
, make

switch
beat at

end of
etween

dial to
to the
.5 kc).

point which
ve the no-
make this
has been

ating band,
put.
ANT jack
eter reads

NT.

ed, a final
rs may be
cts caused
ng signals
aph 4.5.3.

accessory
4.0-, 3.1-,
table 5-2).
ers are in-
bandwidth
ignals; and
sed in CW
s best for
narrower
nterfering
W filters.

covering the
can easily
ceiver) is
ion; filters
e CW1 and
To install
screw the
n, remove
er position;

filter
5-2 is
s this
and 4
ver (as
will be
hed in

ny filters,
FF-STBY-
nd tune to

SECTION 4
Service Instructions

maximum S-meter indication
(power loss). See figure 4-2 for
transformers T4 and T5.

at switch S7, pin 5. Connect a length
of this switch pin. Connect the other
end of the wire with one lead of 135-uuf
capacitor to pin 1 on the SPARE filter socket
(nearest to transformer T4). Connect
the other lead to a ground pin adjacent to the
connections.

one wire at transformer T5, pin 1, and
the other on the SPARE filter socket (one of
transformer T5). To the same filter
socket, connect one lead of a 130-uuf capacitor (see note).
Solder the other capacitor lead to a ground pin adja-
cent to the connections. Solder all connections.

Insert the required AM mechanical filter into the



T4



T5

um

SECTION 4

Service Instructions

7 Replacement of Dial Lamps.

To replace the dial lamp, refer to figure 6-2 (index 4) for location of dial lamp DS1.

4.7.1 DIAL LAMP INSTALLATION.

Refer to figure 4-3 for lamp installation. Remove light bracket from lamp shield to allow access to the lamp bulb. After replacing lamp (use no 47), position the reflector to direct the light in the direction that illuminates the tuning dial.

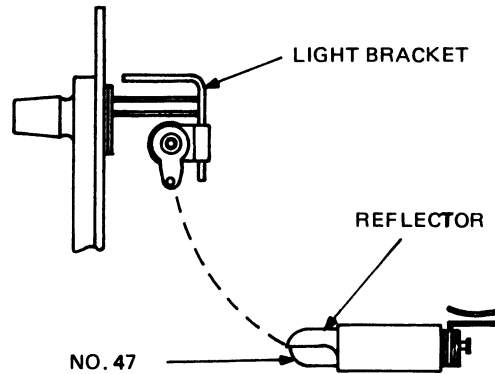

TP4-6626-011

Figure 4-3. Dial Lamp Replacement

5

ions

1. With provide meters, 8.7-mc crystal cover those uencies

n is ap- d by an 125 ma may be peres, volts at

ystals , 3.6 to ic, 14.0 21.0 to nd 28.5

al-plus-

purious nput.

signal.

). 3.0

l. deep.

ACCESSORIES (Sheet 2 of 2)

DESCRIPTION	COLLINS PART NUMBER
Type 312B-4	522-2666-00
d coverage	(See parts list.)
ss filter	526-9496-00
ss filter	526-9497-00
ss filter	526-9498-00
pass filter	526-9495-00
pass filter	526-9446-00
pass filter	526-9494-00
al lattice filter	526-7677-00

