

523-0148000-004311
4th Edition, 1 July 1963



**Rockwell
International**

Collins instruction book

**75S-3 and 75S-3A
Receivers**

**Collins Government
Telecommunications Group
Rockwell International
Cedar Rapids, Iowa 52406**

Printed in the United States of America

We welcome your comments concerning this instruction book. Although every effort has been made to keep it free of errors, some may occur. When reporting a specific problem, please describe it briefly and include the instruction book part number, the paragraph or figure number, and the page number.

Send your comments to: Publications Department
Collins Government
Telecommunications Group
Rockwell International
Cedar Rapids, Iowa 52406

table of contents

		Page
	INSTALLATION	1-1
1	Unpacking	1-1
2	Cabling	1-1
2.1	External Connections	1-1
2.2	Cabling with 32S-3 Transmitter	1-2
2.3	Cabling with KWM-2/2A Transceiver	1-4
2.4	Cabling with Other Transmitters	1-4
3	Initial Checks	1-4
	OPERATION	2-1
1	Calibration	2-1
2	Single-Sideband Tuning	2-1
3	CW Tuning	2-2
4	AM Tuning	2-2
5	RTTY Tuning	2-2
6	Rejection Tuning	2-2
7	Use of S-Meter	2-2
8	Transceiver Operation with 32S-3 Transmitter	2-2
9	Operation Outside Amateur Bands	2-3
	PRINCIPLES OF OPERATION	3-1
1	Block Diagram	3-1
2	R-F and Mixer Circuits	3-1
3	Oscillator Circuits	3-1
3.1	Crystal Oscillators	3-1
3.2	Variable Oscillators	3-1
4	I-F and Detector Circuits	3-2
5	Q-Multiplier and Notch Filter	3-2
6	AGC and Control Circuits	3-2
7	Audio Circuits	3-2
8	Power Supply Circuits	3-2
	SERVICE INSTRUCTIONS	4-1
1	General	4-1
2	Trouble Analysis	4-1
3	Voltage and Resistance Measurements	4-1
4	Signal Tracing	4-3
5	Alignment Procedure	4-3
5.1	455-Kilocycle I-F Alignment	4-4
5.2	Band-Pass I-F Alignment	4-4
5.3	R-F Circuit Alignment	4-5
5.4	VFO Sideband Frequency Shift Adjustment	4-5
5.5	Crystal Calibrator Adjustment	4-5
5.6	VFO Dial Calibration	4-5
5.7	Tunable BFO Alignment	4-6
5.8	Notch Filter Alignment	4-6
5.9	I-F Gain Adjustment	4-6
5.10	S-Meter Zero Adjustment	4-6
6	Installation of Optional Filters	4-7

	Page
.....	5-1
.....	5-1
S.	5-1
Semiconductor C Supplement	5-2
.....	5-2
.....	6-1
.....	7-1
.....	A-1

	Page
.....	1-2
5)	1-3
.....	2-1
-P)	2-4
290-04-2X)	2-4
.....	3-3
P)	4-4
(C785-05-4)	4-6
nts (C785-08-3)	6-6
(C785-12-P)	6-6
5-14-P)	6-7
am (C785-04-6)	7-1

	Page
A	1-1
Bands.	2-3
nts	4-2
.....	4-3
nductors	5-2
.....	5-2

section 1

installation

CAUTION

Connect the a-c power cord to the line until power plug P6 has been inserted into J13. To avoid damage to the receiver, make sure the key on P6 is engaged with the keyway on J13.

For receiver for mute operation, a means of muting and while receiving must be applied. Opening this circuit mutes the normally closed contacts on a relay with the transmitter may be used for use this circuit, the receiver must be in STBY position.

The jack is a high-impedance, low-voltage (0.2 volt rms, typical) to the receiver. A tone oscillator may be applied to this

-3/3A

	PART NUMBER
Options	361-0062-00
	264-4070-00
	544-3121-00
	368-0138-00
Options	523-0148-00
	523-0755-820
Options	280-2946-00
	024-2900-00
	024-9730-00
	024-0019-00
	024-9710-00

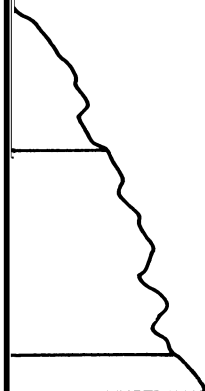

SEE NOTE 2

PLIED. IF
NECT GREEN
OUND.

G-58C/U cables indi-
meter and two inches
ontrol cables. If the
4-ohm speaker, such
D jack on receiver.
ver directly to ANTI-
PHONE PATCH and

3A and the 32S-3 for
atch cables furnished
t as follows:

5S-3/3A as shown in

AL OSC jack J7(under
o 32S-3 RCVR XTAL
ohm dummy load plug
UT jack, and plug it
k J7.

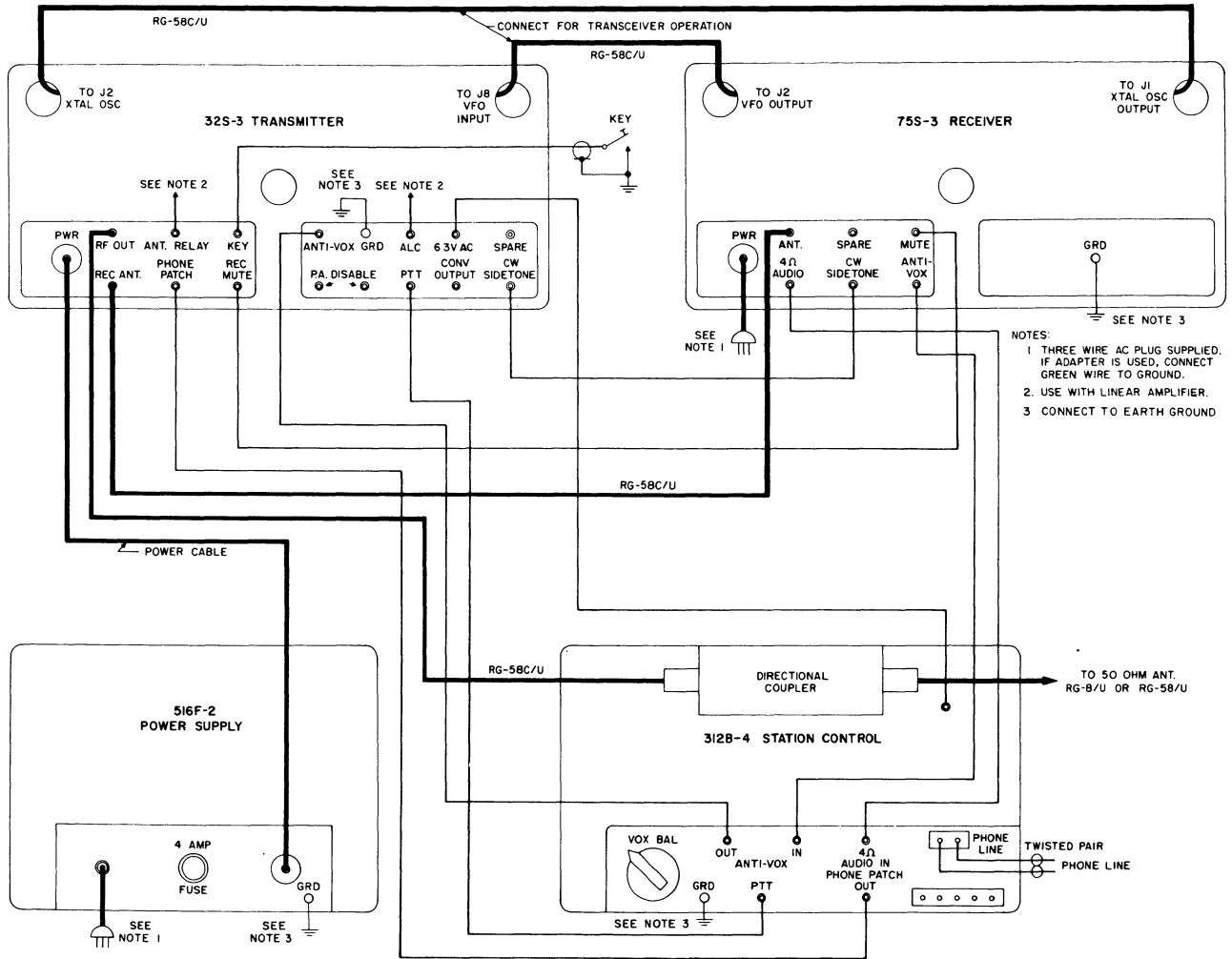

Figure 1-2. Station Interconnections

TERS.

g 75S-3/3A
6 on J102
TE jack on
ver ANTI-
dio) in the

, connect a
o receiver

s of trans-
d anti-vox
he require-
aph 1.2.1.

ummy load
C OUTPUT
ransceiver
make sure
iate jacks.
n the audio
or all r-f
Mu-Metal
l coil L10.

2 ion

pt set
fully

band.
signal

sired

back-
ay be

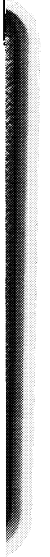

lined in
position.
nob (13)

t the dot
reading

then will
e signals
he mark
ob to the

reduced
ECTION
ontrol is
on. The
p rather
lockwise
oves the
nd. It is
himself
he notch
.
ration, it
t of R77.

relative
al meter
l of 100
is set at
Its. Due
e thresh-
; corres-
er of db
alibrated
, an S-9
increase
gc is not
bitrarily
l meter
o slightly
taken as

s outlined

REC VFO

-3/3A to

ired band
position

n normal
s operate
s not used

SECTION 2
Operation

licate the
ible with-

er service
the same

ation, remove
r signals, re-
ck (under top
plug in the

coverage out-
ed by plugging
ounting board.
ounting board
.0-megacycle
ve segments,
ency range of
otal coverage
of the crystal
ndicate which
over a 200-kc
segment. For
eter coverage

pecific 200-kc

nd is 11.8 mc
is equal to the

COVERAGE

· 5.0 mc

· 9.5 mc

· 15.0 mc

- 22.0 mc

- 30.0 mc

l in section 6,

ELECTION are
f coverage from
ropriate crys-
e BAND switch
TOR to approxi-
Peak the PRE-
tion. The ANT,
se marked C in
ked if optimum
ies outside the
ossible to peak
e frequency or at
rom the crystal
correct setting
nd.

to the 75S-3A
ds are provided
board is located
, refer to para-
elector (10) is
ion, the above-
cuit. The crys-
or both boards.
ent to the BAND
A pencil may be
made.

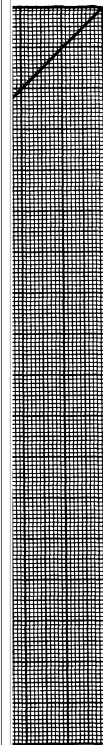

41
s-
on.
r-
ct
er
he
er
e-
ly
is
the

ls
ro-
the
ver

ked
the
tor
al-
ode
the
age
lt-
is
tch
ad-
ual
16.
out
put
ker
ver
the
in

an-
ter
age
c-
is
81
fo.
ru-
tor
of
pfo

so
al
ed
el
on
se

ed
n-
ol
as
es
er
ol
e-
he
n-
8.
he
er
is
er
ng

e-
is
E-
it.
olt
ge
ge
ee
m
n-
m
o-
d-
k,
r-
re
ts

e,
is
ge
n-
ps
om
nd
ce
s-
or

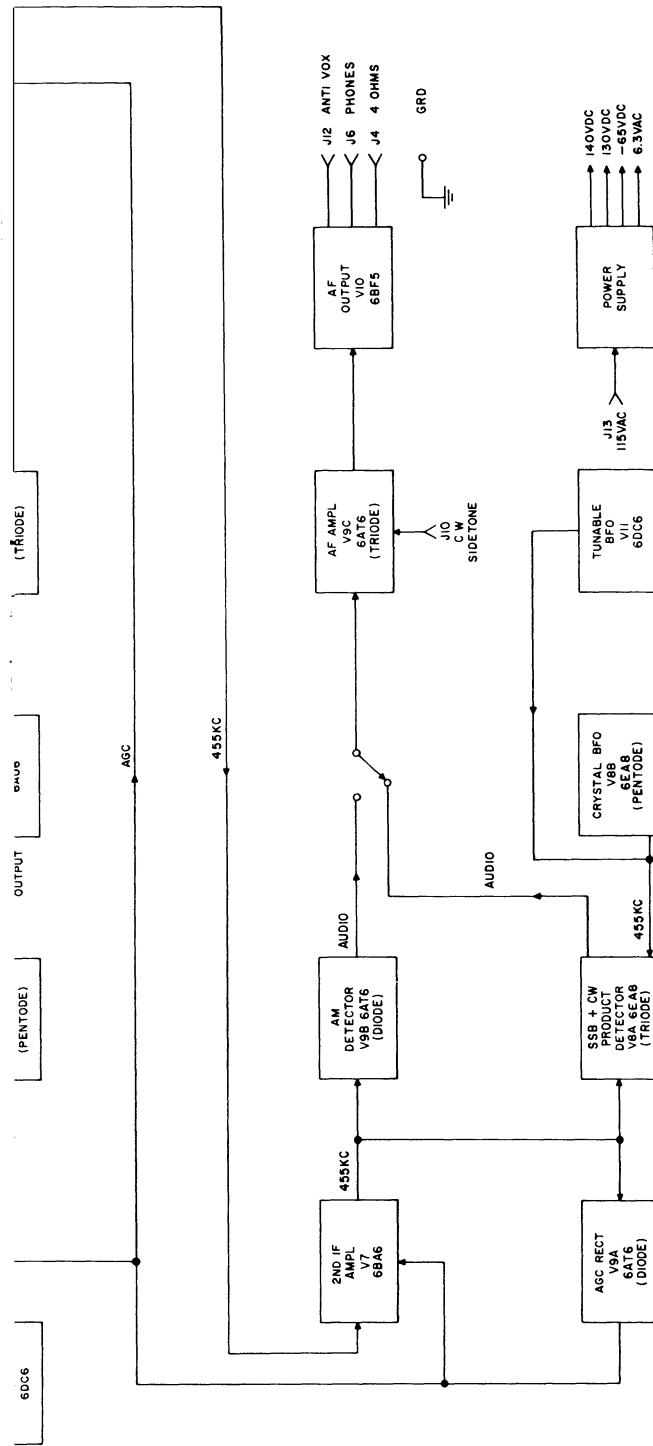

Figure 3-1. Block Diagram

on 4

uctions

on. When this
and apply a
pe pins. Re-
in the socket
ors will often
t and crack,
ements listed
pe of trouble

junction with
n, block dia-
ating trouble.
s properly in
n the SSB or
ector should
used for AM
eat-frequency
ched into the
rd possibility
have failed.

he factory or
led report of
vicing agency
of time and
t when inter-

ts.

ance readings
ose of the vfo
lake all mea-
s:

set RF GAIN
MISSION switch
OPR position,
OFF, and AGC

e with power

made with all
disconnected.
isted as zero.
licated socket

sed for these
t has an input
ms per volt.
om will yield
uits such as
easurements.

SECTION 4
Service Instructions

TABLE 4-1. VOLTAGE AND RESISTANCE MEASUREMENTS

TUBE	TUBE SOCKET TERMINAL								
	1	2	3	4	5	6	7	8	9
V1 CAL ON DCV CAL OFF DCV ACV OHMS	-52 0 1 MEG	+0.7 52 1000*	0 0	6.3 0	105 142 230K**	51 142 220K**	0 0 0		
V2 DCV ACV OHMS	-0.8 6 MEG	0 0	0 0	6.3 0	138 18K** ①	72 60K**	0 0		
V3 DCV ACV OHMS	112 18K** ①	-11 100K	130 17K** ①	0 0	6.3 0	130 17K** ①	0 0	3.6 1000	0 230K
V4 DCV ACV OHMS	120 18K** ①	0 82	120 18K** ①	6.3 0	0 0	120 19K** ①	4.4 1000	5.4 680	2.7 100K
V5 DCV ACV OHMS	138 18K** ①	-0 100K	1.1 680	0 0	0 0	143 18K** ①	0 340K	1.1 680	6.3 0
V6 DCV ACV OHMS	-0.8 3.7 MEG	0 0	0 0	6.3 0	138 0	74 19K** ①	2.2 22K ①		
V7 DCV ACV OHMS	-0.8 3.6 MEG	0 0	0 0	6.3 0	138 19K** ①	72 23K** ①	0.62 85		
V8 DCV ACV OHMS	46 120K**	-3.2 1 MEG	48 240K**	6.3 0	0 0	112 20K** ①	0 0 ②	0 5	-2.7 5600
V9 DCV ACV OHMS	1.1 680K	2.7 12K	6.3 0	0 0	-0.9 3.5 MEG	0 CW, SB 23 AM ∞ CW, SB 220K AM	100 120K**		
V10 DCV ACV OHMS	-11 250K	0 0	6.3 0	0 0	127 18K** ①	122 18K** ①	-11 250K		
V11 ON DCV OFF DCV ACV OHMS	-2 0 47K	0 25 0 ③	6.3 0	0 0	128 128 20K** ①	30 128 38K**	0 0 0		

*FUNCTION switch in CAL position

**Resistance may vary depending upon diode and electrolytic condition

① Reverse VOM leads and take highest of the two readings

② Tunable BFO switch OFF

③ Tunable BFO switch ON

TABLE 4-2. SIGNAL LEVELS

SIGNAL INJECTION POINT	GENERATOR OUTPUT FREQUENCY	GENERATOR OUTPUT VOLTAGE	NORMAL INDICATION
V10 - pin 1	1000 cps	5.4 volts	1-watt audio output
V9 - pin 1	1000 cps	0.2 volt	1-watt audio output
V8 - pin 9	455 kc	75 millivolts	1-watt audio output
V8 - pin 6	BFO INJECTION		1.65 volts r-f (each bfo)
V7 - pin 1	455 kc	48 millivolts	Agc threshold
V6 - pin 1	455 kc	175 microvolts	Agc threshold
V4 - pin 6	455 kc	1400 microvolts	Agc threshold
V4 - pin 7	VFO INJECTION		2.0-2.5 r-f volts
V4 - pin 2	3.055 mc	100 microvolts	Agc threshold
V3 - pin 8	HF OSC INJECTION		0.8-2.0 r-f volts
V3 - pin 9	14.1 mc	30 microvolts	Agc threshold
V2 - pin 1	14.1 mc	9 microvolts	Agc threshold
J5 (ANT)	14.1 mc	1.5 microvolts	Agc threshold

4.4 Signal Tracing.

Appropriate test points and normal signal levels are listed in table 4-2. The values listed are nominal. Signal levels in a given receiver may differ from those listed by a factor of plus or minus 20 percent without noticeable degradation in performance. A signal generator with an accurately calibrated output attenuator must be used to provide the r-f signal source voltages indicated. A Hewlett-Packard model 606A or equivalent generator is recommended for this purpose. Be sure to consult the signal generator instruction book for information regarding output termination requirements. Measurements of oscillator injection voltages require the use of an r-f vtm such as the Hewlett-Packard model 410B. Make r-f and audio measurements under the following conditions:

a. For audio measurements, use an audio oscillator as the signal source and an a-c vtm or calibrated oscilloscope to monitor receiver audio output. If desired, an audio wattmeter may be used. Set AF

c. To check r-f signal levels, connect a d-c vtm to the receiver agc line. Set RF GAIN at maximum. Static d-c voltage on the agc line should be approximately -1.0 volt. Connect the r-f signal generator to the point indicated in the table, and rock the generator dial to produce maximum agc voltage. Starting from minimum output, increase signal generator output to the point where a further increase in signal produces a slight increase in agc voltage. This is agc threshold. Note generator output voltage, and compare with the value listed in the table.

4.5 Alignment Procedure.

Complete alignment of the receiver may be accomplished using the crystal calibrator as a signal source and the S-meter as a peak indicator. To provide a variable output attenuator for the calibrator, connect a .001-uf capacitor to one end of a 5000-ohm carbon potentiometer. Temporarily connect the free end of the capacitor to tube socket terminal 5 of V1. the crvstal calibrator. Connect

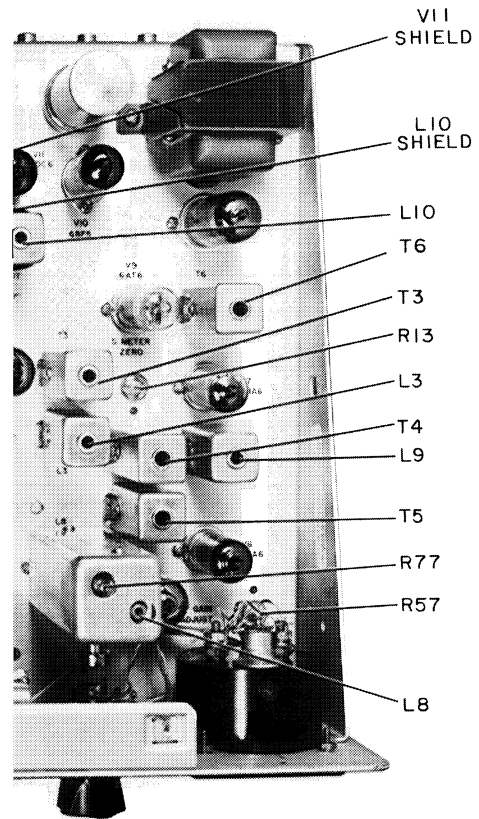

ents

or reading. Rock receiver tuning dial to
 e signal is centered in filter passband.
 to AM position, and adjust top and bottom
 T4 and T5 for peak meter reading. This
 alignment.

ignal generator is used for this alignment,
 o tube V301, connect generator to pin 2
 nd adjust frequency to center of filter
 . Align as outlined above, disconnect gen-
 nd replace V301.

D-PASS I-F ALIGNMENT.

MISSION switch to CW, and tune to the
 signal at 3.7 mc.

two swamping networks by connecting a
 acitor in series with a 1000-ohm resistor
 ctg alligator clips to the two remaining

4
ons

OR
nal

for
st.
at-

for
the
re-
as
to
is,
ers
the
6.6
ing

eat
ner
ust

to
not

100
the

li-
on
no
cal
ent
ing
ake

ch
t at

d of
een

. to
the
(c).
top

the
r at

ter signal in
tone).
scale (pointer

maximum depth
pointer reading.
y to ring or

al generator
is required.
ceiver ANT
tput at 28.6
rator signal,
luces a just-
al reading on
stment until

erating band,
output.
ort ANT jack

-meter reads

S:
IS,

P
ER
OR
TOR

SECTION 4
Service Instructions

y to provide a good fit around the filter. The filter has three terminals, one of which is insulated around it. This is the case with respect to this terminal and either one of the other two terminals to chassis ground. Either terminal on the opposite end of the filter is used for the ground connection indicated. Rewire wiring carefully to prevent shorts. Do not use spaghetti from removed wiring.

When installation and wiring are completed, turn the instrument on and tune to the calibrate signal at 14.0 MHz. Adjust the filter trimmer capacitors for maximum signal reading with the signal centered in the band. Available filters and installation kit are listed in table 5-2.

section 5

Specifications

front panel. With the
meters, 20 meters,
the 28.5- to 28.7-mc
Remaining crystal
nal 10-meter cover-
substituted for those
at other frequencies

Consumption is approxi-
provided by an ex-
50 volts d-c at 125
Filament power may
volts at 5.5 amperes,
or 24 to 28 volts at

crystals furnished,
3 mc, 3.6 to 3.8 mc,
4.2 to 7.4 mc, 14.0 to
18 to 15.0 mc, 21.0 to
to 21.6 mc, and 28.5

or AM.

plus-noise to noise

2 kc at 60 db down.
25 kc at 60 db down.
5 kc at 60 db down.

b. Internal spurious
valent antenna input.

ter midband

antenna input signal.

.8 watts maximum.

e, 12-1/2 in. deep.

	TYPE
c	6AT6
	6BF5
	6DC6
	6AU6
	1N1490
	1N1490
	HC7004
r	1N732
	1N34A
	47
se	2 amp

LLINS NUMBER
.166-00
.167-00
.479-00
.480-00
.481-00
.665-00
.666-00
Parts List.
.9338-00
.9339-00
.9340-00
.095-00

	COLLINS PART NUMBER
	360-0088-00
1-1B p. 13E	360-0088-00 360-0136-00
55-mc	278-1721-00
-1A	
ohms hned ct	240-2564-00
and,	240-0149-00
amp	668-0020-00
s d-c an	240-2540-00
CY:	278-0653-00
CY: l	278-0277-00
urns by and 3-1	278-0655-00
d-c an	240-2533-00
turns part	240-0084-00
s d-c s	240-0084-00 240-0193-00
ha,	458-0044-00
- rall;	544-3143-002
EC- s lg lden	426-1464-00
pe	372-1952-00
hms	745-1499-00
ms	745-1422-00
s	745-1352-00
ohm	745-1450-00
R3	745-1352-00
R3	745-1352-00
ms	745-1429-00
ms	745-1303-00
R3	745-1352-00
R3	745-1352-00
ohm	745-1436-00
R8	745-1303-00

SECTION 6
Parts List

DESCRIPTION	COLLINS PART NUMBER
FIXED, COMPOSITION: 0.33 megohm Allen-Bradley type EB	745-1457-00
FIXED, COMPOSITION: 47 ohms Allen-Bradley type EB	745-1296-00
plier	
plier	
FIXED, COMPOSITION: same as R74	745-1457-00
FIXED, COMPOSITION: same as R2 10)	745-1422-00
VARIABLE: 100,000 ohms $\pm 30\%$, 1/4 S13; Allen-Bradley type CB	376-2530-00
FIXED, COMPOSITION: 27,000 ohms Allen-Bradley type EB	745-1412-00
FIXED, COMPOSITION: 39,000 ohms Allen-Bradley type EB	745-1419-00
FIXED, COMPOSITION: 10,000 ohms Allen-Bradley type EB	745-1394-00
FIXED, COMPOSITION: same as R84	745-1394-00
FIXED, COMPOSITION: same as R3	745-1352-00
FIXED, COMPOSITION: same as R75	745-1296-00
RTARY: 1 circuit, 14 position, 1 oving, 16 fixed contacts; Oak Mfg. Co. 73-OK1	259-0981-00
CTION, ROTARY: 1 circuit (1 pole) 14 oving, 16 fixed contacts (p/o 75S-3A fg. Co. type CK	269-1977-00
CTION, ROTARY: 1 circuit, 14 posi- ng, 10 fixed contacts; Oak Mfg. Co.	269-2027-00
CTION, ROTARY: same as S2	269-2027-00
CTION, ROTARY: same as S2	269-2027-00
CTION, ROTARY: 1 section, 4 position. fixed, 3 moving contacts; Oak Mfg.	259-0949-00
CTION, ROTARY: 2 circuit (2 pole) 2 moving, 11 fixed contacts; Oak Mfg.	269-2309-00
CTION, ROTARY: 2 circuit (2 pole) 12 oving, 10 fixed contacts; Oak Mfg. Co. 456-F	269-2310-00
CTION, ROTARY: 2 circuit (2 pole) 12 oving, 9 fixed contacts; Oak Mfg. Co.	269-2311-00
plier	
RTARY: 3 circuit (3 pole) 4 position, 4 fixed contacts (includes S6); Oak t no. 217828-52	259-1483-00
RTARY: 1 circuit (1 pole) 3 position, fixed contacts; Grigsby Co., Inc. type	259-1491-00
RTARY: 1 circuit (1 pole) 2 position, ntact, 3 fixed contacts (p/o 75S-3A Mfg. Co. part no. 191774-23	259-0980-00
MER, RADIO FREQUENCY: 3.4 to 30 s C24, C26)	543-8120-002
MER, RADIO FREQUENCY: 3.4 to 30 s C44, C81)	543-8122-002
MER AND COIL ASSEMBLY: 3.055 mc in. by 25.32 in. by 2.875 in. overall; ions Coil part no. X-185-1A and	278-1721-00
MER, INTERMEDIATE FREQUENCY: kc frequency range; Communications X-083-1	278-0281-00
MER, INTERMEDIATE FREQUENCY:	278-0281-00
MER, INTERMEDIATE FREQUENCY:	278-0281-00
MER, AUDIO FREQUENCY: pri 2500 500 ohms and 4 ohms (includes C35, r Electronics part no. 27232	667-0302-00
MER, POWER: pri. 115 v, 50 60 cps. overall 220 v CT; sec. no 2. 6.3 v 03, C108); Stancor Electronics part	662-0301-00
TUBE: glass envelope; pentode; of America part no. 6DC6	255-0226-00
TUBE: same as V1	255-0226-00
TUBE: miniature pentode; Radio erica part no. 6EA8	255-0379-00
TUBE: same as V3	255-0379-00

	COLLINS PART NUMBER
50-kc frequency; 05	290-8705-00
50-kc frequency; 06	290-8706-00
500-kc frequency;	290-8454-00
	522-1093-00
20 uuf ±20%, 500 051	913-2879-00
20 uuf ±20%, 500 050	913-2880-00
20 uuf ±20%, 500 049	913-2881-00
20 uuf ±20%, 500 048	913-2882-00
20 uuf ±20%, 500 042	913-2883-00
20 uuf ±20%, 500 038	913-2884-00
100 uuf ±20%, 931-022	913-2897-00
100 uuf ±20%, 931-020	913-2898-00
100 uuf ±20%, 932-008	913-2899-00
100 uuf ±20%, 932-009	913-2900-00
20 uuf ±1%, 500 v 20F102F500WV	912-1749-00
20 uuf ±10%, 500 v 20F302F500WV	912-1748-00
20 uuf ±1%, 300 v 15E201F300WV	912-3468-00
100 uuf ±2%, 932-005	913-0074-00
100 uuf ±2%, 933-017	913-0246-00
0.02 uf +60% c Co. part no.	913-2097-00
same as C306	913-2097-00
MIC: 5.0 uuf min Resistor part no.	917-1073-00
same as C306	913-2097-00
same as C306 rt no. 1N34A	353-0103-00
L301	543-7323-00
single layer wound, Delevan	543-7333-00
10 megohm ±10%,	240-0695-00
100 ohms ±10%,	745-1436-00
same as R301	745-1433-00
INDUCTANCE: pri. 380 uh type; Communication	240-0665-00
General Electric	255-0202-00

SECTION 6
Parts List

CRYSTALS AVAILABLE

OPERATING FREQUENCY (mc)	PART NUMBER	CRYSTAL FREQUENCY (kc)	FOR OPERATING FREQUENCY (mc)	PART NUMBER
-14.2	290-9062-00	12977.500	22.8-23.0	290-9106-00
5-14.35	290-9180-00	13077.500	23.0-23.2	290-9107-00
-14.4	290-9063-00	13177.500	23.2-23.4	290-9108-00
-14.6	290-9064-00	13277.500	23.4-23.6	290-9109-00
-14.8	290-9065-00	13377.500	23.6-23.8	290-9110-00
-15.0	290-9066-00	13477.500	23.8-24.0	290-9111-00
-15.2	290-9067-00	13577.500	24.0-24.2	290-9112-00
-15.4	290-9068-00	13677.500	24.2-24.4	290-9113-00
-15.6	290-9069-00	13777.500	24.4-24.6	290-9114-00
-15.8	290-9070-00	13877.500	24.6-24.8	290-9115-00
-16.0	290-9071-00	13977.500	24.8-25.0	290-9116-00
-16.2	290-9072-00	14077.500	25.0-25.2	290-9117-00
-16.4	290-9073-00	14177.500	25.2-25.4	290-9118-00
-16.6	290-9074-00	14277.500	25.4-25.6	290-9119-00
-16.8	290-9075-00	14377.500	25.6-25.8	290-9120-00
-17.0	290-9076-00	14477.500	25.8-26.0	290-9121-00
-17.2	290-9077-00	14577.500	26.0-26.2	290-9122-00
-17.4	290-9078-00	14677.500	26.2-26.4	290-9123-00
-17.6	290-9079-00	14777.500	26.4-26.6	290-9124-00
-17.8	290-9080-00	14877.500	26.6-26.8	290-9125-00
-18.0	290-9081-00	14977.500	26.8-27.0	290-9126-00
-18.2	290-9082-00	15077.500	27.0-27.2	290-9127-00
-18.4	290-9083-00	15177.500	27.2-27.4	290-9128-00
-18.6	290-9084-00	15277.500	27.4-27.6	290-9129-00
-18.8	290-9085-00	15377.500	27.6-27.8	290-9130-00
-19.0	290-9086-00	15477.500	27.8-28.0	290-9131-00
-19.2	290-9087-00	15527.500	27.9-28.1	290-9142-00
-19.4	290-9088-00	15577.500	28.0-28.2	290-9132-00
-19.6	290-9089-00	15627.500	28.1-28.3	290-9143-00
-19.8	290-9090-00	15677.500	28.2-28.4	290-9133-00
-20.0	290-9091-00	15727.500	28.3-28.5	290-9144-00
-20.2	290-9092-00	15777.500	28.4-28.6	290-9134-00
-20.4	290-9093-00	15827.500	28.5-28.7	290-9201-00
-20.6	290-9094-00	15877.500	28.6-28.8	290-9135-00
-20.8	290-9095-00	15927.500	28.7-28.9	290-9145-00
-21.0	290-9096-00	15977.500	28.8-29.0	290-9136-00
-21.2	290-9097-00	16027.500	28.9-29.1	290-9146-00
-21.4	290-9098-00	16077.500	29.0-29.2	290-9137-00
-21.6	290-9099-00	16127.500	29.1-29.3	290-9147-00
-21.8	290-9100-00	16177.500	29.2-29.4	290-9138-00
-22.0	290-9101-00	16227.500	29.3-29.5	290-9148-00
-22.2	290-9102-00	16277.500	29.4-29.6	290-9139-00
-22.4	290-9103-00	16327.500	29.5-29.7	290-9149-00
-22.6	290-9104-00	16377.500	29.6-29.8	290-9140-00
-22.8	290-9105-00	16477.500	29.8-30.0	290-9141-00

ART AND FRAME

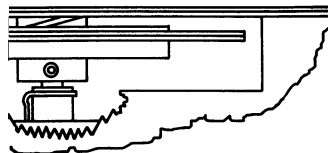

Components

C1, C72, C73, C74
20, S2, T2

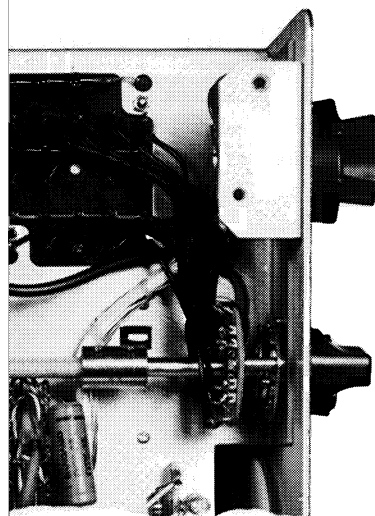

ts Location

SECTION 6
Parts List

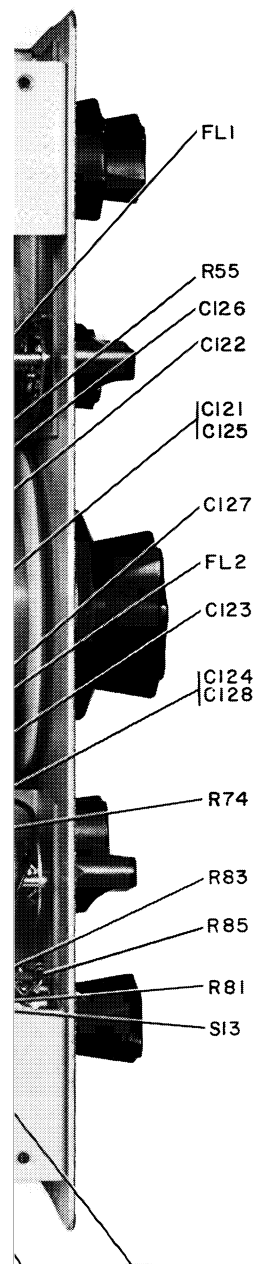

57 R70 THRU R75
C37, C129, C130
L7, C135

section 7

illustrations

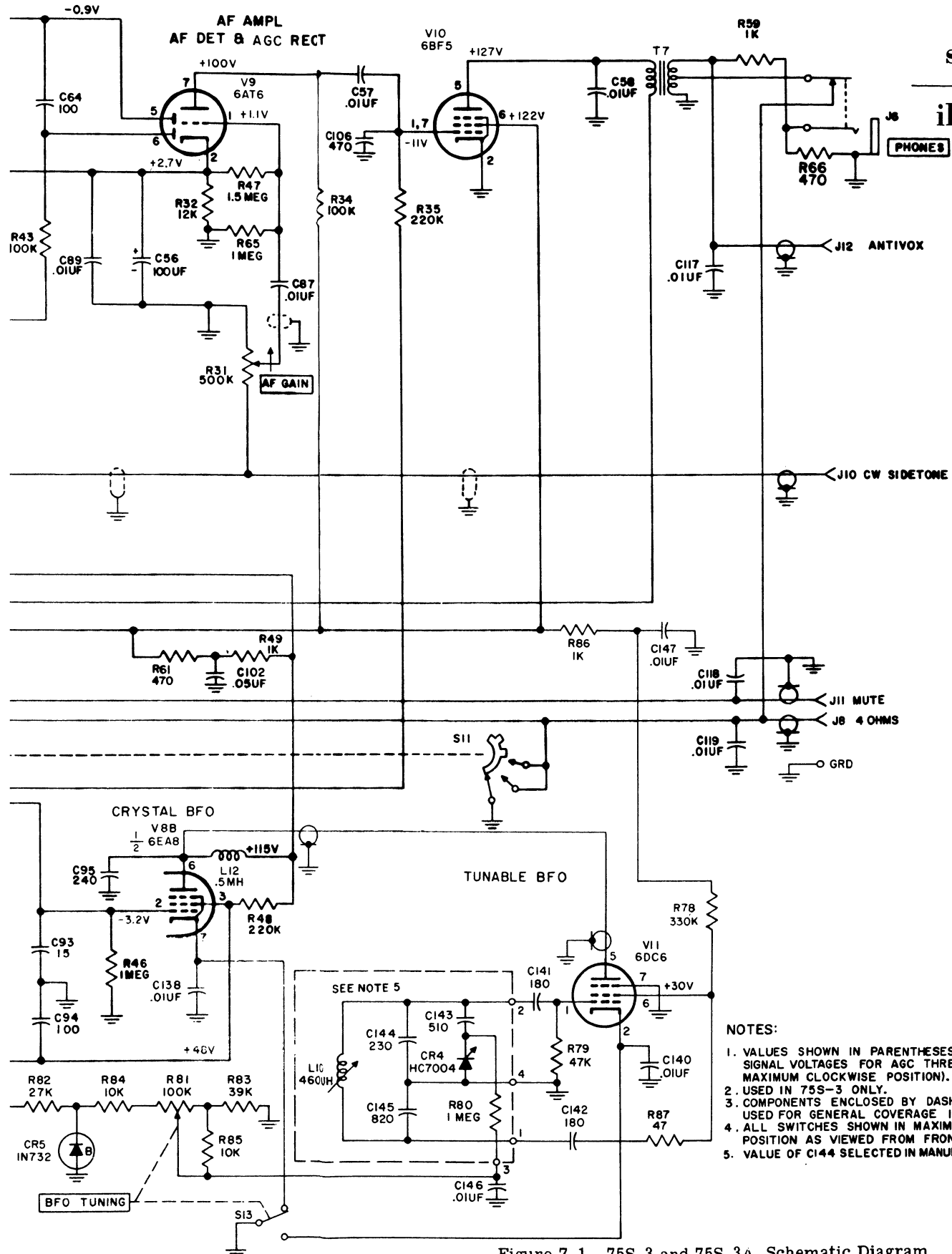

- NOTES:
1. VALUES SHOWN IN PARENTHESES ARE NOMINAL SIGNAL VOLTAGES FOR AGC THRESHOLD (RF GAIN MAXIMUM CLOCKWISE POSITION).
 2. USED IN 75S-3 ONLY.
 3. COMPONENTS ENCLOSED BY DASHED LINE ARE USED FOR GENERAL COVERAGE IN 75S-3A ONLY.
 4. ALL SWITCHES SHOWN IN MAXIMUM COUNTERCLOCKWISE POSITION AS VIEWED FROM FRONT PANEL.
 5. VALUE OF C144 SELECTED IN MANUFACTURE.

Figure 7-1. 75S-3 and 75S-3A, Schematic Diagram

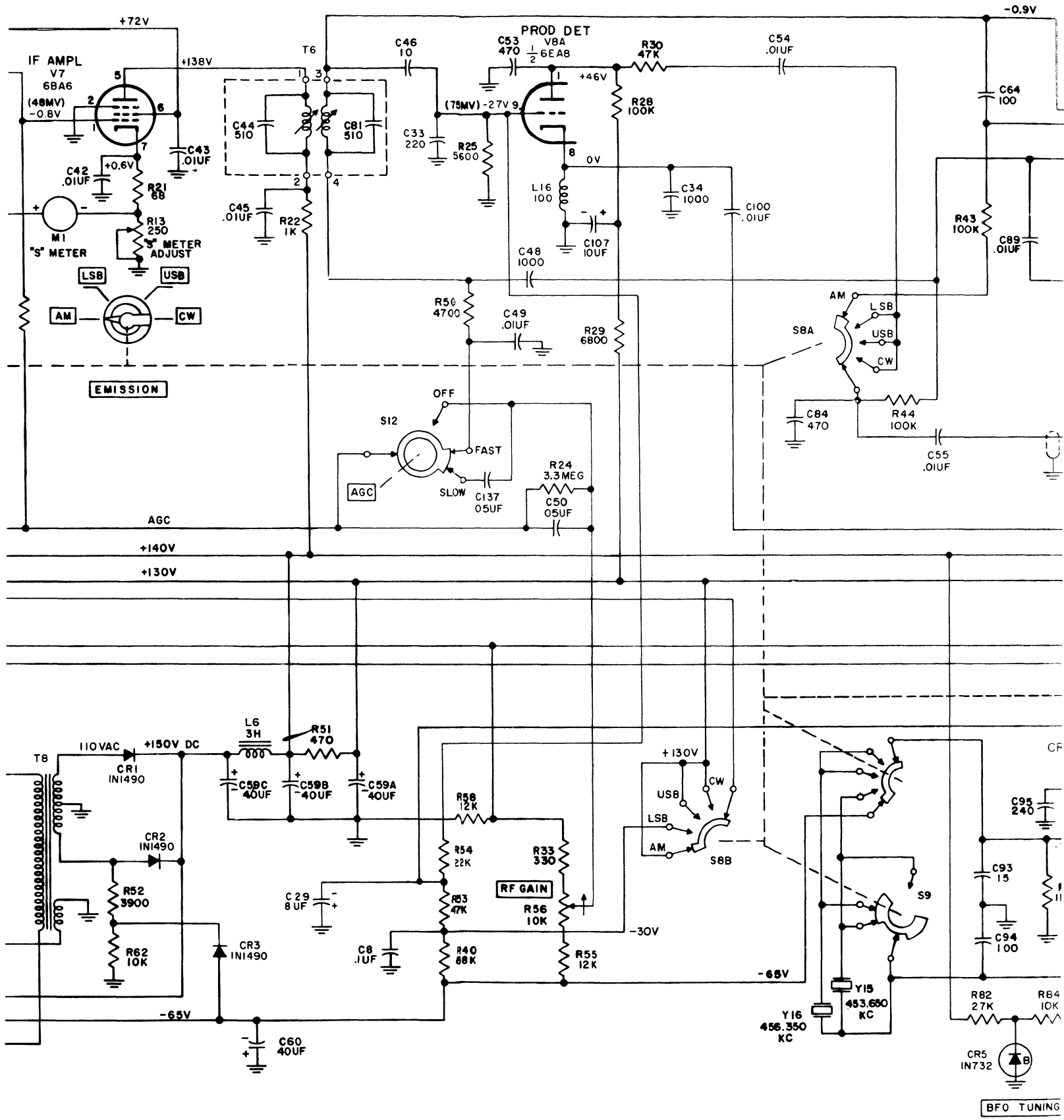

BFO TUNING

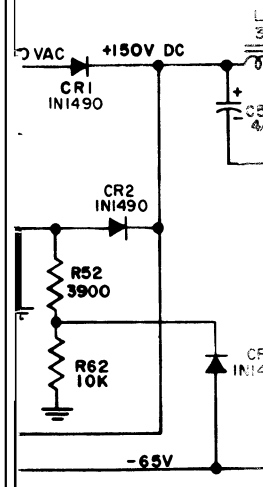
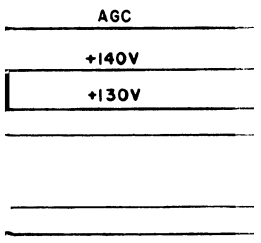
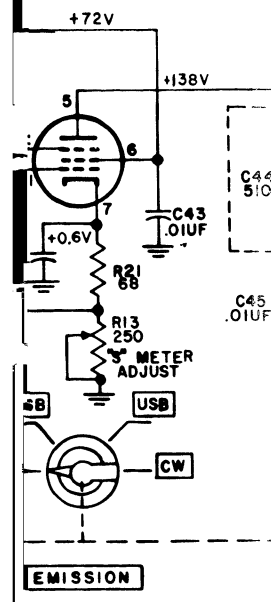

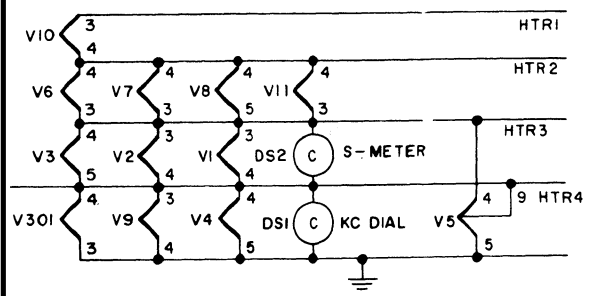
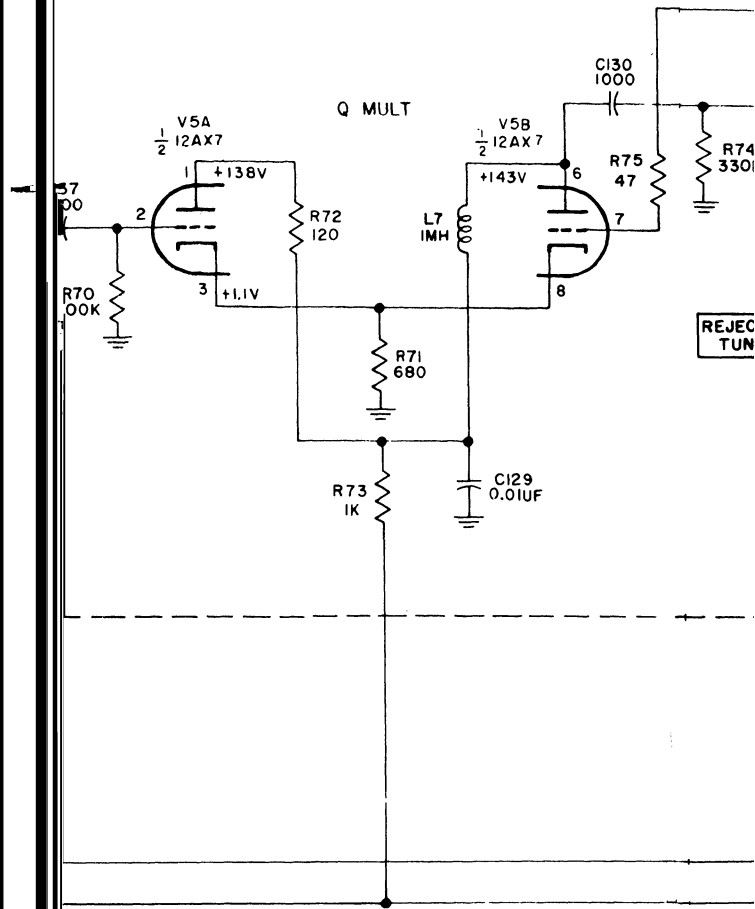

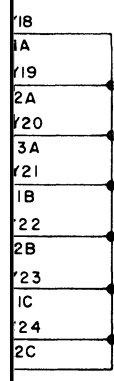
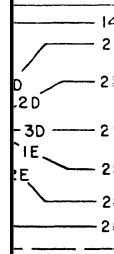
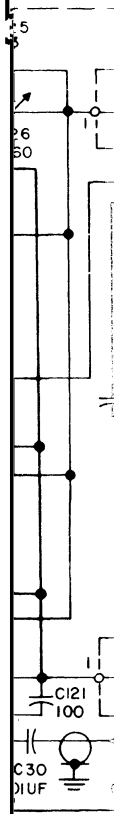

FIRST MIXER

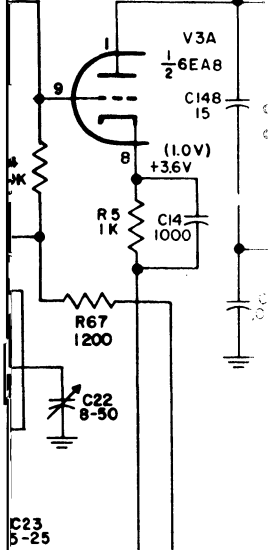

CRYSTAL OSC
V3B
1/2 6EA8

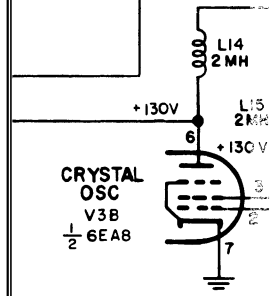

A MATEUR

