

TS-520S SPECIFICATIONS

Downloaded by
Amateur Radio Directory

SECTION 1. INTRODUCTION

1-1 KENWOOD TS-520S

The TS-520S is a highly sophisticated solid state amateur radio transceiver employing only three vacuum tubes.

Operating on all amateur bands between 1.8 and 29.7 MHz, this unit is constructed modularly. All major electronic circuits are wired on easily removed or installed circuit boards. The TS-520S includes many built-in features usually found as extras on other transceivers. Included in the equipment are a VOX circuit, a 25 kHz crystal calibrator, an RIT circuit, a RF attenuator, and an effective noise blanker. The TS-520S also includes automatic gain control

transceiver with little difficulty. If openwire or balanced type transmission line is used with the antenna, a suitable antenna tuner is recommended between the transceiver and the feed line. Methods of construction and operating such tuners are described in detail in the ARRL Antenna Handbook, and similar publications. For operation on the 160, 75 and 40 meter bands, a simple dipole antenna, cut to resonance in the most used portion of the bands, will perform satisfactorily. For operation of the transceiver on the 10, 15, and 20 meter bands, the efficiency of the station will be greatly increased if a good directional rotary antenna is used. Remember that even the most powerful transceiver is

For antenna adjustments, the transceiver may be loaded lightly, using the TUN position instead of operating at full power output. This will limit tube dissipation during adjustments, and will also help to reduce interference on the fre-

■ EXTERNAL SPEAKER AND HEADPHONES

Receiver audio output from the TS-520S is 1 watt at 4 to 16 ohms. The TS-520S has a built-in speaker. However, if an external speaker is desired for fixed station or mobile opera-

SECTION 2. INSTALLATION

2.1 UNPACKING

Remove the TS-520S from its shipping box and packing material and examine it for visible damage. If the equipment has been damaged in shipment, save the boxes and packing material and notify the transportation company immediately. It is a good idea to save the boxes and packing material in any case because they are very useful for shipping or moving the equipment.

The following accessories should be included with the transceiver:

Operating Manual	1	AC Power Cord	1
Microphone Plug	1	Speaker Plug	1
Jumpered 9-pin Plug	1	8P US Plug	1
RCA Phono Plugs	3	Fuse (6A × 2, 4A × 2,	
Alignment Tool	1	2A × 1)	5
Plastic Extension Feet with Screws	2		

2.2 OPERATING LOCATION

As with any solid state electronic equipment the TS-520S should be kept from extremes of heat and humidity. Choose an operating location that is dry and cool, and avoid operating the transceiver in direct sunlight. Also, allow at least 3 inches clearance between the back of the equipment and any object. This space allows an adequate air flow from the ventilating fan to keep the transceiver cool.

2.3 CABLING (See Figure 1)

■ GROUND

To prevent receiving an electric shock, TVI and BCI, select a good, effective ground for installation and then connect an earthing wire to the backside of GND terminal. Use a heavy earth line as big as possible, it is because short-line wiring is regarded as most effective for operation.

■ ANTENNA

Connect a 50 ohms antenna feedline to the coaxial connector on the rear panel.

■ KEY

If CW operation is desired, connect a key to the KEY jack.

■ POWER CONNECTIONS

Make sure the POWER switch on the front panel of the TS-520S is turned off, the stand-by switch is put in the REC position, and that the voltage switch on the back of the TS-520S is switched to the correct line voltage (120 or 220). Connect the POWER cord to an appropriate external power source.

■ SPEAKER

If an external speaker is desired, connect a cord to the SPEAKER jack on the back of the TS-520S and to the SPEAKER jack on the back of the SP-520 (or to an external 8 ohm speaker).

■ MICROPHONE

Attach the microphone connector to a suitable microphone as shown in Fig. 2. Be sure that the PTT switch of the microphone is separate from the microphone circuit, as shown in Fig. 3.

It should be noted that a microphone with a 3P plug having a common earth terminal cannot be used.

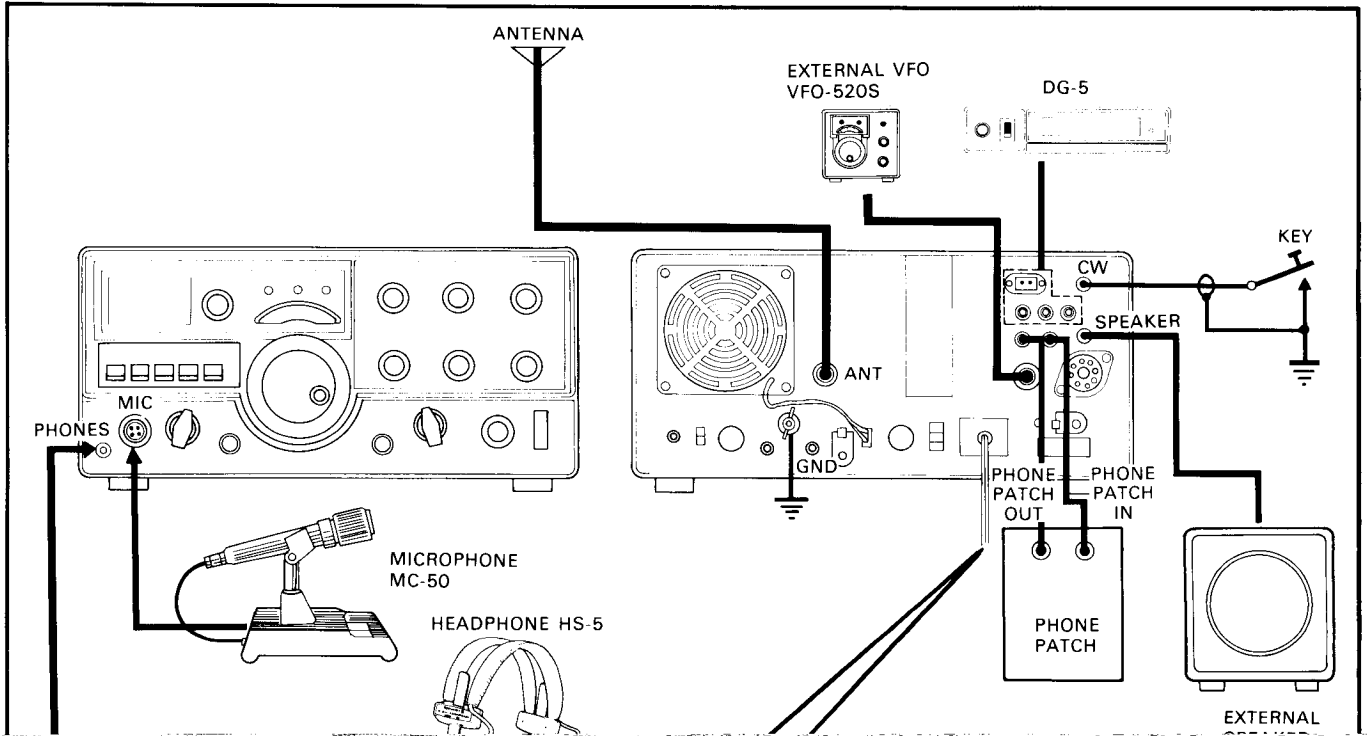

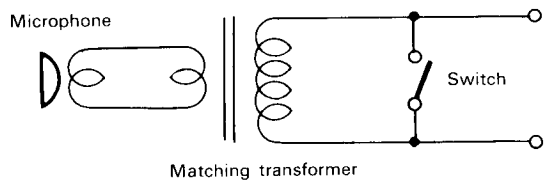

(1) Unsuitable for PTT operation.

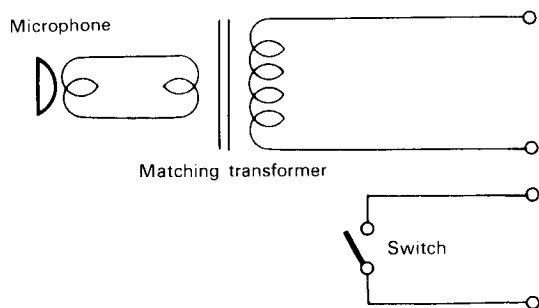

(b) Suitable for PTT operation.

Fig. 3 A Suitable PTT Microphone

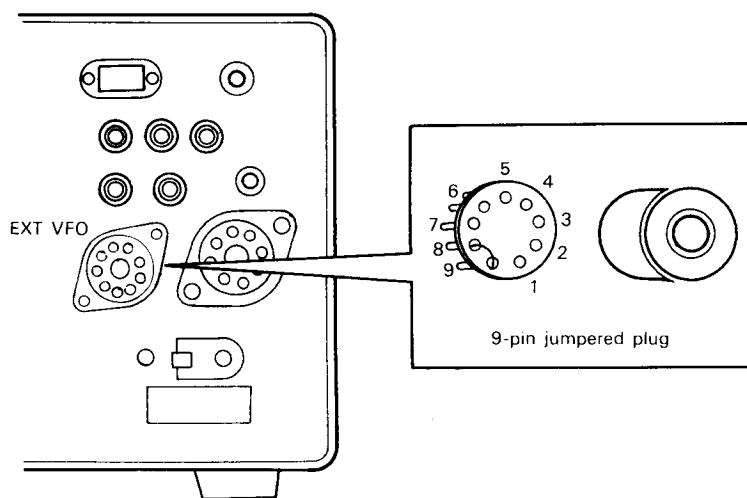
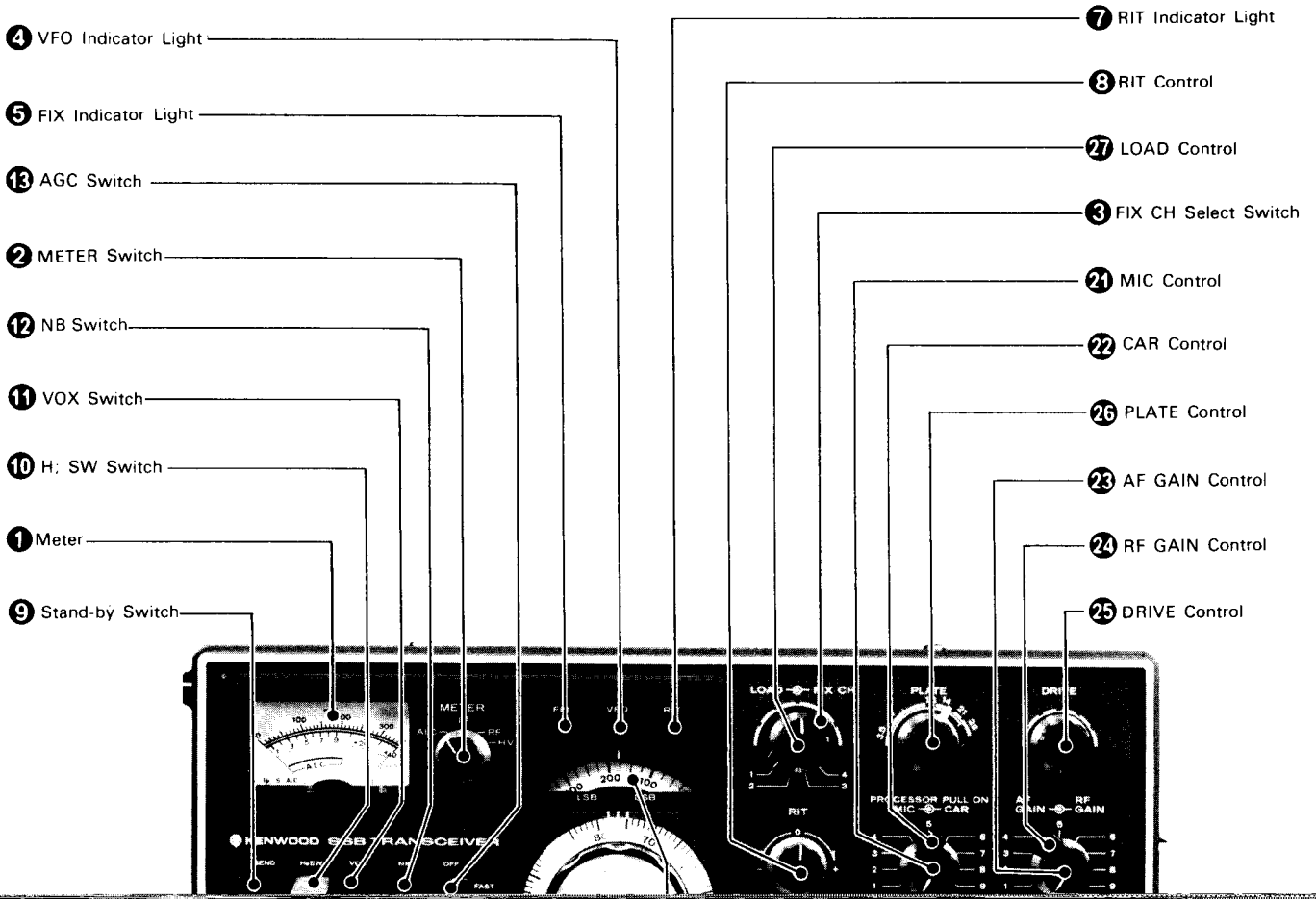

Fig. 4 Back Panel Jumpered EXT VFO Connector

SECTION 3. OPERATING CONTROLS



3.1 FRONT PANEL CONTROLS (See Figure 5)

■ METER (1 on Figure 5)

The meter monitors five different functions, depending on the position of the METER switch. In receive the meter is automatically an S-meter. The S-meter shows received signal strength on a scale of 0 to 40 db over S9. In transmit the meter function depends on the position of the METER switch, as described below.

■ METER SWITCH (2 on Figure 5)

The position of the METER switch determines the function of the meter. The switch selects one of the following functions (see Table 4 for nominal meter readings):

ALC (Automatic Level Control)

In this position the meter monitors the ALC voltage of the internal ALC circuit (or the ALC voltage feedback from a linear amplifier operated in conjunction with the TS-520S). For SSB operation the ALC reading for voice peaks should be within the indicated ALC range of the meter. The ALC voltage adjustment is made with the MIC control for SSB and with the CAR control for CW.

IP (Plate Current)

In this position the meter monitors the plate current of the final tubes. The meter scale is calibrated from 0 to 350 ma.

RF (Output Power)

In this position the meter monitors the relative output power of the transceiver. There is no meter scale for this position. Normally the reading should be adjusted with the RF VOLT control for a 2/3 scale meter reading.

HV (High Voltage)

In this position the meter monitors the high voltage from the power supply. The meter scale is calibrated from 6 to 10, indicating 600 to 1000 volts.

transceiver's operation. The indicator is not lighted during fixed channel, or remote VFO, operation.

■ FIX (FIXED CHANNEL OPERATION) INDICATOR LIGHT (6 on Figure 5)

The FIX indicator is a light emitting diode which illuminates whenever the TS-520S's internal fixed frequency oscillator is controlling the transceiver's operation.

■ RIT SWITCH (6 on Figure 5)

This push-button switch turns the RIT (Receiver Incremental Tuning) circuit on and off. With the switch depressed, the circuit is activated and the RIT indicator is lighted. The RIT control can then adjust the receiver frequency independently of the transmit frequency for VFO operation.

■ RIT INDICATOR (7 on Figure 5)

This light emitting diode is illuminated when the RIT circuit is turned on, showing that the transmit and receive frequencies may be different.

■ RIT CONTROL (8 on Figure 5)

When the RIT switch is pressed on, this potentiometer tunes the TS-520S's receiver. The RIT circuit allows the operator to tune the receive frequency more than ± 2 kHz without changing the transmit frequency.

At the zero (mid-point) position the receive frequency is the same as when the RIT circuit is turned off.

■ STAND-BY SWITCH (9 on Figure 5)

This two-position lever switch selects one of the following functions:

REC The transceiver is receiving unless the microphone PTT switch is switched to transmit, or the VOX circuit is activated.

TX The TS-520S is locked into the transmit

MAN..... With the switch in this position, the transceiver is switched into transmit or receive by the stand-by switch or the PTT switch on the microphone.

VOX..... With the switch in this position, the VOX circuit is turned on for voice operated transmit on SSB semi-automatic break-in operation on CW.

■ **NB SWITCH** (12 on Figure 5)

The NB switch turns the built-in noise blanker circuit on and off. The noise blanker is designed to reduce pulsating ignition type noises. When the lever switch is flipped up, the circuit is turned on.

■ **AGC SWITCH** (13 on Figure 5)

The AGC switch controls the AGC (Automatic Gain Control) circuit giving the operator three choices:

OFF..... It may be desirable to turn the AGC off when receiving a very weak signal.

FAST..... The FAST AGC position is designed for use in CW operation.

SLOW..... Use the SLOW AGC position for SSB operation.

LSB This switch position selects the LSB circuits for operating on lower sideband. International amateur practice dictates the use of LSB on the 1.8, 3.5 and 7 MHz.

■ **BAND SWITCH** (16 on Figure 5)

This 10-position switch selects all the necessary circuits to tune the transceiver to the desired 600 kHz band.

■ **FUNCTION SWITCH** (17 on Figure 5)

This 7-position rotary switch selects one of the following transceiver functions.

CAL-FIX..... This position allows calibration of the TS-520S's internal VFO to one of the transceiver's fixed frequency channels (if an optional fixed channel crystal is installed). With the switch in this position a signal is generated at the selected fixed channel frequency and the main tuning knob can be tuned to zero beat the calibrating signal.

CAL-RMT..... This position allows calibration of the VFO-520S (remote VFO) to the transceiver's operating frequency. With the switch in this position, the transceiver generates a calibrating signal and the VFO-520S can be tuned to zero-beat the calibrating signal.



3.2 SIDE PANEL CONTROLS

The 5 controls located on the left side of the transceiver are covered by a protective panel. The cover is removed by simply pulling the two black fasteners.

■ **RF VOLT CONTROL** (1 on Figure 6)

Use the RF VOLT control to adjust the sensitivity of the RF output function of the meter. Adjust it for a 2/3 scale reading during CW transmission.

■ **BIAS CONTROL** (2 on Figure 6)

The BIAS control adjusts the bias voltage of the two S2001A (6146B) amplifier tubes. Turning the control clockwise increases the idling plate current of the tubes. Section 4 describes adjustment of the bias current.

■ **DELAY CONTROL** (3 on Figure 6)

The DELAY control adjusts the holding time of the VOX circuit for VOX or break-in CW operation. The control will have to be adjusted to the preference of the individual operator.

■ **ANTI VOX CONTROL** (4 on Figure 6)

This control adjusts the level of the anti VOX signal fed in to the VOX circuit. Adjust the control to prevent feedback of the speaker from tripping the VOX circuit.

■ **VOX GAIN CONTROL** (5 on Figure 6)

This control adjusts the sensitivity of the VOX circuit by adjusting the gain of the VOX amplifier, for voice control led operation.

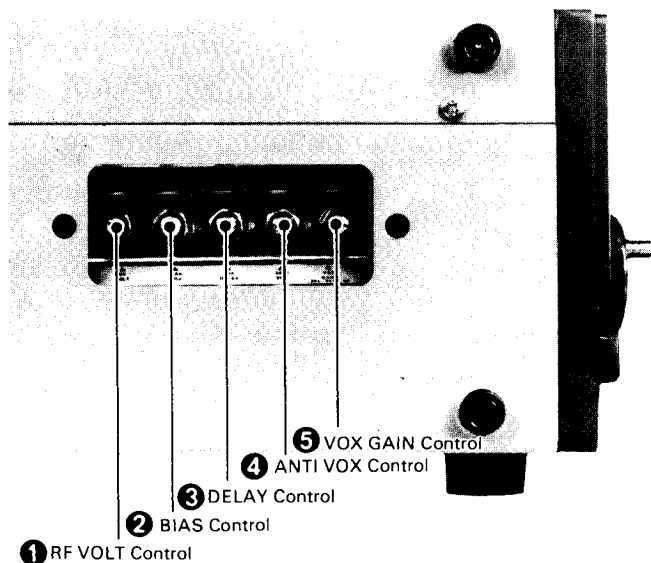

Fig. 6 Side Panel Controls

3.3 REAR PANEL CONTROLS (See Figure 7)

■ **COOLING FAN** (1 on Figure 7)

This fan cools the RF amplifier section of the TS-520S to insure reliable and efficient operation.

■ **TRANSVERTER OUT JACK** (2 on Figure 7)

This is the low level RF output jack for use with a VHF transverter.

■ **TRANSVERTER IN JACK** (3 on Figure 7)

This is the RF input jack for input from a VHF transverter.

■ **TRANSVERTER CONNECTOR** (4 on Figure 7)

This 12-pin connector is used to control an accessory VHF transverter.

PIN	FUNCTION	PIN	FUNCTION
1	ALC	7	Transverter in
2	No connection	8	Normally closed relay contact
3	+210V DC	9	Ground
4	No connection	10	+210V DC
5	-100V DC	11	No connection
6	Transverter in	12	Ground

■ **X VERTER SWITCH** (5 on Figure 7)

When VHF Transverter (TV-502S) is connected to the transceiver, the selection of HF or VHF is automatically accomplished by setting the transverter switch to ON or OFF.

■ **ANTENNA CONNECTOR** (6 on Figure 7)

This SO-239 coax connector should be attached to a suitable antenna for transmitting and receiving. See Section 1.2 for a discussion of an appropriate antenna.

■ **POWER SUPPLY CONNECTOR** (7 on Figure 7)

This 12-pin connector is used to connect an AC or DC power source to the transceiver.

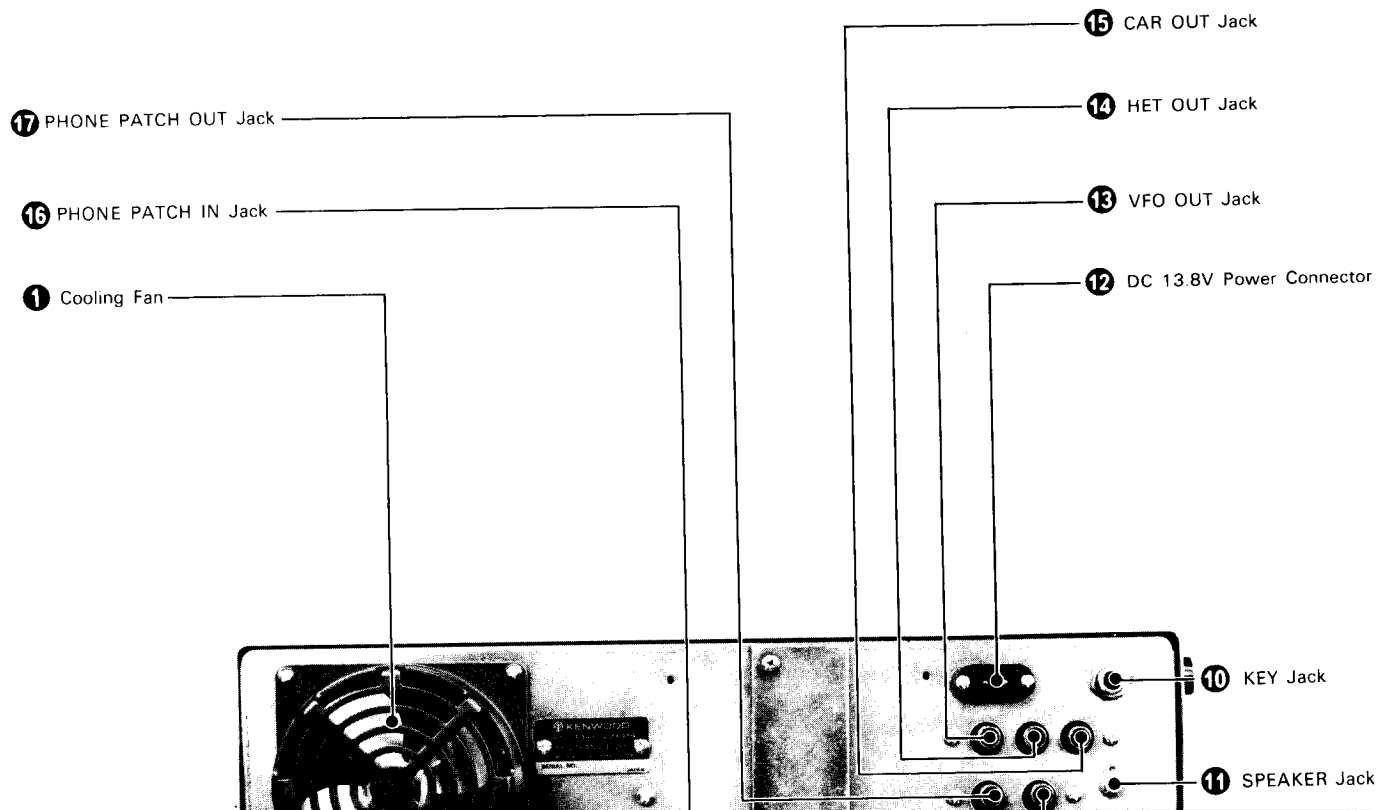

PIN	FUNCTION	CONNECTION FOR AC OPERATION	CONNECTION FOR DC OPERATION
1	Ground	No connection	⊖ 13.8V DC
2	Power direct (Connect to pin 3 for remote AC power switching)	No connection	Jumper to 4, 7, 9, 11 and 12
3	AC power common	120/220V AC	No connection
4	+ 13.8V DC to control DC module	No connection	Jumper to 2, 7, 9, 11 and 12
5	No connection	No connection	No connection
6	Power switching	120/220V AC	⊕ 13.8V DC
7	12.6V AC (or 13.8V DC) to heaters	Jumper to 10	Jumper to 2, 4, 9, 11 and 12
8	13.8V DC to pin 9 in AC operation	Jumper to 9	No connection
9	13.8V DC to operate solid state circuits	Jumper to 8	Jumper to 2, 4, 7, 11 and 12

PIN	FUNCTION	PIN	FUNCTION
1	Ground	5	Normally open relay contact
2	No connection	6	ALC feedback ALC threshold level approx. -6V
3	Normally closed relay contact	7	No connection
4	Ground	8	External speaker Load impedance 4 ~ 16Ω

■ **EXTERNAL VFO CONNECTOR (19)** on Figure 7)

This 9-pin connector provides a means of interconnecting the KENWOOD VFO-520S, another external VFO. The interconnecting cable is provided with the VFO-520S. The 9-pin jumpered VFO plug provided with the TS-520S must be inserted in this socket for normal transceiver operation.

PIN	FUNCTION	PIN	FUNCTION
1	VFO signal	6	Calibrator signal (9V DC)
2	VFO signal shield	7	No connection
3	Ground	8	9V DC to internal VFO (pin 9)
4	12.6V AC	9	9V DC to external VFO
5	Relay voltage (+ on transmit)		

■ **SG SWITCH (20)** on Figure 7)

The SG slide switch controls the screen grid voltage on the final tubes. For tuning or neutralizing the TS-520S you can set the switch to the OFF position. Turn the switch back to the ON position for normal operation. The SG voltage is on when the switch is up and off when the switch is down.

■ **GND (Ground) LUG (21)** on Figure 7)

To prevent accidental shocks from the chassis, as well as interference, connect a good earth ground to this lug.

■ **AC VOLTAGE SELECT SWITCH (22)** on Figure 7)

This slide switch switches the primary of the power transformer to select 120 or 220V AC operation.

■ **EXTERNAL RECEIVER ANTENNA JACK (23)** on Figure 7)

This is an antenna connector to which an external receiver, for example, a sub-receiver, is connected.

■ **RECEIVER ANTENNA SWITCH (24)** on Figure 7)

This switch connects the antenna to the TS-520S at the NORMAL position and to the external receiver at the REC ANT position.

Example: Changing power voltage from 220V to 120V.

Remove screw and stopper plate

Switch stopper to opposite side

Lock lever by attaching stopper plate to opposite side screw

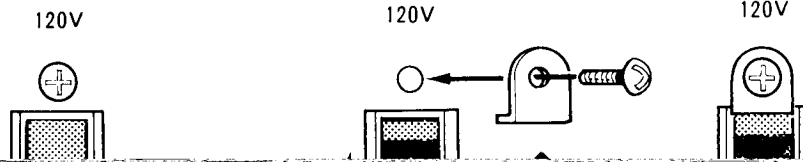

SECTION 4. OPERATING INSTRUCTIONS

4.1 PRELIMINARY PROCEDURE

Set the MIC and CAB controls to zero and the MODE switch

reception with the H. SW switch turned to OFF. Advance the AF GAIN control clockwise until some receiver noise is heard in the speaker. Turn the main tuning dial within the

Example: BAND Switch — 14.0
Sub-dial — between 200 and 300
Dial Scale — 80
Operating Frequency —
14.0 MHz + 200 kHz
+ 80 kHz = 14.280 MHz

When the TS-520S is correctly calibrated, as described below, the center dial pointer shows the operating frequency for CW. The left dial pointer shows the operating frequency for LSB operation and the right dial pointer shows the operating frequency for USB operation.

For modification of the wiring, disconnect the brown lead from the CWR terminal and connect it to the LSB terminal; similarly, disconnect the gray lead from the CWT terminal and connect it to the CWR terminal.

4.4 CALIBRATION

■ NORMAL TRANSCEIVER CALIBRATION

Turn the FUNCTION switch to CAL-25 kHz to activate the crystal calibrator. Be sure the RIT switch is OFF. Turn the main tuning knob to receive one of the marker signals which are generated at 25 kHz intervals. For greatest accuracy

USB Use the procedure described above with the MODE switch turned to USB. Use the USB (right-hand) dial pointer.

CW Set the mode switch to TUNE to zero beat the marker signal. Then, turn the main dial and calibrate the frequency using the center dial pointer.

If the TS-520S has a CW filter installed, tune the VFO for maximum S-meter deflection when receiving the marker signal. Calibrate the dial scale to the center pointer as described above.

■ CALIBRATING THE TS-520S TO A FIXED CHANNEL FREQUENCY

Turn the FUNCTION switch to CAL-FIX to calibrate the TS-520S's VFO to a fixed channel frequency. Tune the VFO to the channel frequency selected and zero beat the generated marker signal. At zero beat the VFO and crystal frequencies coincide.

By calibrating the VFO for normal operation, as described

The DRIVE control does not tune the transceiver for WWV reception.

4.6 RF GAIN

RF GAIN is controlled by changing the voltage of the AGC circuit. Adjust the RF GAIN knob so that the S-meter does not cause excessive deflection. This minimizes the noise during reception and allows the S-meter to indicate the correct signal strength. For normal operation, this knob should be turned fully clockwise for maximum sensitivity.

4.7 NOISE BLANKER

The TS-520S has a sophisticated built-in noise blanker designed to reduce ignition type impulse noise. The noise blanker is particularly important for mobile operation. When necessary, activate the noise blanker circuit by flipping the NB switch up.

4.10 RF ATT

If the transceiver is operated in a short-distance (within several hundred meters) and strong signals of nearby frequencies are received, the wanted signals are blocked. Also, if the wanted signals are very strong, the S-meter is scaled out. In this instance, set the RF ATT switch to ON. The input signals to the RF amplifier are attenuated by about 20 db, providing distortionless reception.

4.11 TRANSMITTER TUNING

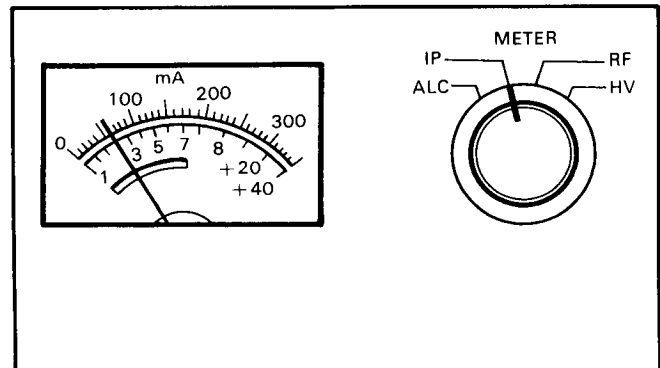

■ **DRIVE TUNING** (See Figure 11)

Shift the METER switch to ALC and the MODE switch to TUN and peak the ALC reading (maximum meter deflection) with the DRIVE control. The stand-by switch is in the SEND position for adjustment.

NOTE: _____

If there is no ALC reading indicated, increase the CAR control until there is an ALC reading.

■ **PLATE AND LOAD TUNING**

CAUTION: _____

When the MODE switch is in the CW position the final tubes draw full plate current in transmit. Final tube life is directly related to the length of tune-up periods. Do not transmit with the tubes out of resonance for more than 10 seconds at a time.

NOTE:

International amateur practice dictates using USB or LSB on the following bands.

1.8 MHz Band	CW
3.5 MHz Band	LSB
7.0 MHz Band	LSB
14.0 MHz Band	USB
21.0 MHz Band	USB
28.0 MHz Band	USB

Key the transmitter and speak into the microphone with the tone of voice used in normal operation. Adjust the MIC control until voice peaks are just within the top limit of the ALC range printed on the meter scale. The METER switch is in the ALC position. If the transmitter section is driven beyond this range, the transmitted signal will be distorted.

■ VOX OPERATION

Adjust the transceiver as described in the previous paragraph. Flip the VOX switch on and close-talk into the microphone, increasing the VOX GAIN control (on the left side of the TS-520S) until the VOX relay just operates. For VOX operation it is desirable to close-talk the microphone to prevent background noises from tripping the TS-520S

CW transmissions are automatically monitored through the speaker of the transceiver. The audio gain of the sidetone can be adjusted with VR2 on the AF board (X50-0009-01).

For semi-break-in operation, turn the VOX switch on. Hold the key down and increase the VOX GAIN control, on the left side of the transceiver, until the VOX relay just operates. It is desired to change the release time constant of the VOX circuit, adjust the DELAY control, also on the left of the transceiver.

The plate current for CW operation should be about 200 ma. Use the CAR control to adjust the carrier level for CW operation. At 200 ma of IP there may be no ALC reading.

TABLE 4. Meter Switch Positions for Different Modes

MODE	METER Switch	Approx. Readings
TUN	* ALC or * IP or * RF or HV	Peaked 75 ma 1/3 scale 800V
CW	ALC or * IP or RF or HV	None or within ALC range 200 ma 2/3 scale 750V

4.15 FIXED FREQUENCY OPERATION

The TS-520S has a built-in crystal controlled oscillator for fixed frequency operation. This feature is most useful for commonly used frequencies, nets, or any situation where

■ CW OPERATION

Crystal Frequency (MHz) = 5.5 MHz + X - Operating Frequency (MHz)

X = 1.8 for the 160 meter band

4.16 INTERNAL CROSS CHANNEL OPERATION

The TS-520S contains a unique design feature which allows cross channel operation without a separate external VFO. The TS-520S's internal VFO is used together with the fixed frequency oscillator to allow reception and transmission on different frequencies. The fixed channel oscillator must have one or more accessory crystals installed for this feature to work.

FUNCTION SWITCH	TRANSMIT CONTROL	RECEIVE CONTROL
VFO	VFO	VFO
VFO.R	Fixed channel oscillator	VFO
FIX.R	VFO	Fixed channel oscillator
FIX	Fixed channel oscillator	Fixed channel oscillator

4.17 MOBILE OPERATION

The compact size and solid-state design of the TS-520S make it ideal for mobile use, by using optional DS-1A. Be sure to use a mobile antenna which meets the requirements described in Section 1.

The normal operating procedures, described previously, apply to mobile operation. The noise blanker should be used to reduce ignition and impulse noises for clear reception. Remember that during transmission the transceiver draws about **15 amps** so be careful not to drain the car's battery.

to the instruction label on the bottom of the TS-520S. This adjustment should be made while speaking into your microphone in normal loudness of voice.

It should be noted that the use of a high output microphone may result in distortion of tone quality.

In that case, insert an attenuator to the microphone circuit or connect a 10 ~ 33k ohm resistor (depends on the type of microphone used) in parallel with C13 (100pF) in the generator unit (X52-1090-00) as shown in page 5.

10 ~ 33k ohm (select according to the type of microphone used)

NOTE:
MC-50: Sensitivity to be $-55 \text{ dB} \pm 3 \text{ dB}$ at about 5 cm from microphone (MIC input: 10 mV, 1 kHz)

4.19 SSTV OPERATION

The TS-520S will adapt very well to slow scan television operation. The only cabling required are connections between the PHONE PATCH IN jack (or MIC connector) of the TS-520S and the output of the television console, and between the PHONE PATCH OUT jack (or SPEAKER jack) of the TS-520S and the input of the television console.

Be careful to keep the input power of the transceiver down to a safe level with the MIC control. If you exceed the plate power dissipation capability of the tubes, they will be damaged.

4.20 OPERATION WITH A PHONE PATCH

The TS-520S has rear panel jacks to facilitate using the

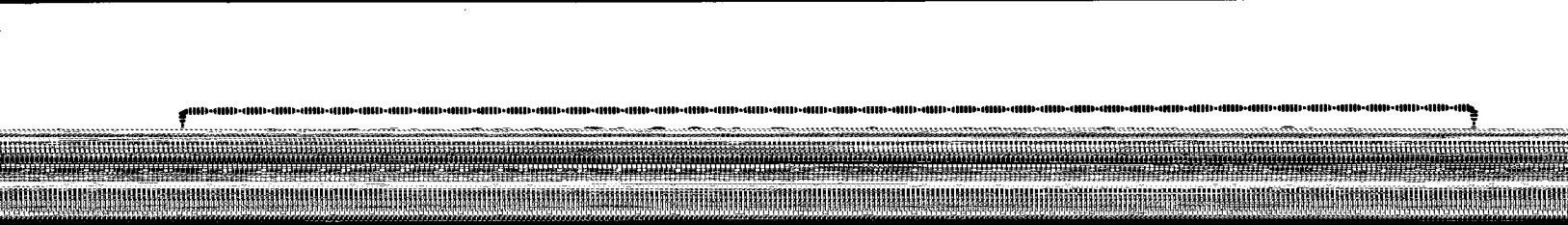

SECTION 5. CIRCUIT DESCRIPTION

5.3 GENERATOR BOARD (X52-1090-00)

The Generator Board, which is a heart of this SSB transceiver, produces a DSB (double side band) signal. The operation is as follows.

The AF signal coming from the microphone is amplified through Q3, Q6, and Q5. The amplified signal is applied to the ring modulator, comprised of four diodes, which produces a carrier-suppressed DSB signal. This DSB signal is amplified through the buffer amplifier Q1 (FET) and is

circuit, which is activated by the PROCESSOR switch located on the front panel. The AF signal output of Q3 is further amplified through Q4, Q8, Q9, and Q10. The amplified signal is delivered to Q6 through the diode switching, which is activated by the PROCESSOR switch. Gain control is made in the manner that the output of Q10 is phase-inverted by Q11, is bridge-rectified by the four diodes, and is DC-amplified through the control amplifier, Q12, to produce a pinch-off voltage which controls the attenuator, Q7 (FET). The desired time constant is obtained at the output of Q12. The actual signal is

5.4 RF BOARD (X44-1200-00)

The RF Board provides the most functions as compared with the other boards of the TS-520S. It consists mainly of a

■ RECEIVE SYSTEM

An amateur band signal coming into the ANT connector enters the ANT Coil Board (X44-1170-00) through the 8

■ WWV RECEIVE CIRCUIT

The TS-520S has a converter circuit for specific use of receiving the WWV wave. The 15 MHz standard wave coming into the antenna passes through the diode switch interlocked with the BAND switch and is applied to T5 where it is stepped up. The signal then is RF amplified

5.5 IF BOARD (X48-1060-01)

The IF Board is important both for the transmit and receive operations. In the transmit mode of operation, the SSB crystal filter, XFI, suppresses the undesirable sideband and carrier of the DSB signal fed from the Generator Board to

Downloaded by

Amateur Radio Directory



5.7 AF BOARD (X49-0008-01)

The AF Board contains a complementary, OTL AF amplifier, a CW semi-break-in circuit, a CW sidetone oscillator for monitoring, and a detector for calibration. Q5 comprises a preamplifier for amplifying audio signal delivered from the ring detector. C15 and C18 in the preamplifier circuit cut out high frequencies. The amplified signal passes through the AF GAIN control, and is amplified through Q1 and Q2, and is further power-amplified through Q3 and Q4.

NOTE: _____

In transmission, Q5 is cut off by the positive voltage appearing at the RL terminal.

The sidetone oscillator, which is of a phase-shift type, oscillates a signal around 750 Hz. The oscillator works only when the MODE switch is set to the CW position and a key is plugged into the KEY jack and is closed.

NOTE: _____

1. If the DC 1A DC 30M...

5.8 VFO BOARD (X40-1070-01)

The VFO Board produces a signal of variable frequency in the range from 5.5 MHz (at division "0" on the Sub-dial) to 4.9 MHz (at division "600"). The oscillator is of a modified Clapp type using a FET. The buffer also uses another FET, which assures very stable oscillation. The buffer follows a harmonic filter and a Darlington output amplifier, Q3 and Q4, which also assures stable operation against load change.

CAUTION: _____

Do not change VFO Board mechanisms and circuits. If repairs are effected by anyone other than an authorized personnel, the performance warranty will become void.

VFO UNIT (X40-1070-01)

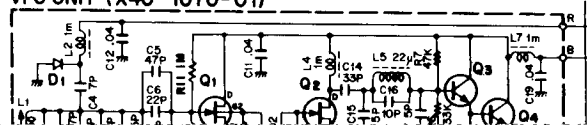

5.10 VOX BOARD (X54-0001-00)

In the SSB mode of operation, the voice signal coming from the microphone amplifier (or the sidetone signal in CW) enters the MV terminal. The signal is amplified through Q3 and is rectified by D6 to a DC voltage in proportion to the input level. When the DC voltage is applied to the base of Q4, this is turned on and lowers the base potential of Q6 down.

If Q4 is cut off with no input signal, the base and emitter of Q5 are at the same potential, thus turning Q5 off. Therefore, C10 is charged through D7 by the voltage preset with the delay control. If Q4 is turned on with the voice signal

5.11 FIXED CHANNEL-AVR BOARD (X43-1100-00)

This board consists of a fixed channel crystal-controlled oscillator, a 9V AVR (automatic voltage regulator), and a -6V DC-DC converter. The crystal-controlled oscillator, comprised of Q1, is of a Pierce C-B type. Q2 and Q3 form a Darlington buffer amplifier, which feeds the oscillation signal out. TC1 through TC4 are trimmers for precisely adjusting the oscillation frequency.

The 9V AVR supplies with 9V DC the main oscillator circuits and control circuits in the TS-520S. The transistor Q4 controls the current of Q5 and Q6.

5.12 RECTIFIER BOARD (X43-1090-02)

This board has all the rectifiers used with the TS-520S. The 800V high voltage is obtained by a voltage doubler rectifier, the 300V, 210V, and C-voltage by a half-wave rectifier, and the 14V voltage by a bridge rectifier.

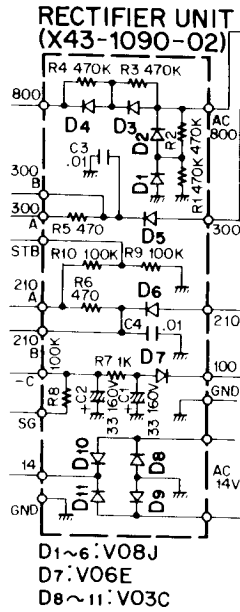

Fig. 24 Rectifier Board

5.13 HV BOARD (X43-1110-00)

The HV (High Voltage) Board has a voltage divider providing a voltage used to indicate the anode voltage of the final

5.14 INDICATOR BOARD (X54-1120-00)

This board has light-emitting diodes "VFO", "FIX", and "RIT" located above the Sub-dial scale. Each diode indicates the turn-on states of the respective functional boards.

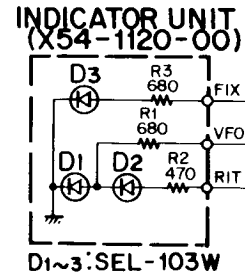

Fig. 26 Indicator Board

5.15 FINAL POWER AMPLIFIER BOARD (X56-1200-00)

This board contains all final power amplifier circuits

SECTION 6. MAINTENANCE AND ALIGNMENT



Rear panel of TS-520S

Downloaded by
Amateur Radio Directory

■ **EXTENSION FEET**

The TS-520S is provided with two extra feet which can be used to raise the front panel of the transceiver. In some

■ **TRANSVERTER (TV-502S)**

To connect the transverter to TS-520S, proceed as follows:

1. Check that the power to the transverter and TS-520S

■ CONNECTION OF VFO-520S

The VFO-520S is developed for further enhancing the capabilities of your TS-520S. Figure 35 shows a connection of the VFO-520S to the TS-520S. Keep the 9-pin MT plug put in the EXT VFO connector on the TS-520S until the VFO-520S is connected to it. The VFO interconnecting cable is supplied as an accessory with the VFO-520S.

Only by controlling the FUNCTION switch on the VFO-520S you can enjoy highly advanced and comprehensive

➤ To calibrate your TS-520S VFO output frequency with the VFO-520S output frequency, proceed as follows:

1. The FUNCTION switch on the TS-520S may be at any position.
2. Set the TS-520S in the receive mode of operation.
3. Set the FUNCTION switch to the CAL-RMT position.
4. Tune the TS-520S VFO output frequency and the VFO-520S output frequency until a zero beat is heard when two frequencies coincide with each other.

For more detailed information of the VFO-520S, read the "OPERATING MANUAL FOR VFO-520S"

■ FIXED CHANNEL CRYSTAL INSTALLATION

Section 4.15 describes fixed frequency operation with the TS-520S. To install the accessory crystals, remove the transceivers top cover and locate the FIXED CHANNEL-AVR board directly behind the VFO.

Insert the crystal in the desired channel position (the positions are labeled on top of the VFO case) and use the appropriate trimmer (TC1 through TC4) to net the crystal. The CAL-FIX feature of the TS-520S can be used to net the crystals as described in Section 4.4.

6.3 RECEIVER RF SECTION ALIGNMENT

The stand-by switch of the transceiver should be in the REC position during all of the receiver adjustments. Connect the transceiver to a 50 ohm dummy load.

Turn the FUNCTION switch to CAL-25 kHz and use the output of the calibrator circuit to adjust the coils. Set the DRIVE control to the 12 o'clock position (the white line pointing towards the top of the transceiver). The coils can be aligned from the bottom of the transceiver without removing the boards.

Set the BAND switch to the correct band and tune the VFO to the frequency shown in the table below to receive the calibrator signal. Use the test rod included in the accessory bag to tune the antenna and mixer coils for a maximum S-meter reading. Figure 37 shows the location of the coils. Adjust the coils for each band as described below. When you finish, turn the calibrator off. Adjust only the antenna

CAUTION:

The Antenna cores are fragile. Be careful not to break them during alignment.

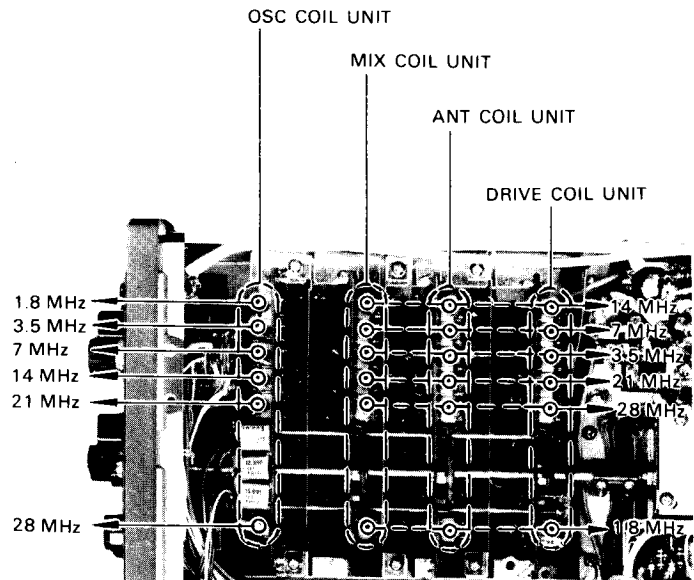

Fig. 37 RF Section Coil Diagram

■ HETERODYNE CRYSTAL OSCILLATOR

Adjust the heterodyne crystal oscillator's coils by switching the BAND switch to each band and tuning the appropriate coil (see Figure 37) as described below.

Turn the core of the coil clockwise until the crystal stops

57 20

■ WWV ALIGNMENT

Turn the BAND switch to WWV and tune the set dial to

6.6 FIXED CHANNEL-AVR BOARD
ALIGNMENT

6.9 TRANSMITTER NEUTRALIZATION

The TS-520S requires neutralization every time either of the final tubes is changed.

Tune up the TS-520S into a 50 ohm dummy load at 28.5 MHz for CW operation as described in Section 4. Set the SG switch to off (down) and place a sensitive RF voltmeter across the dummy load. Flip the stand-by switch to SEND and adjust TC1 (reached through the adjustment hole in the top of the final section) for a minimum reading on the voltmeter. After the final section is neutralized, flip the stand-by switch to REC and slide the SG switch on.

A good receiver tuned to 28.5 MHz, works very well for neutralizing if an RF voltmeter is not available. Instead of tuning for a minimum voltage, tune for a minimum S-meter reading.

CAUTION:

Neutralization of the final section should be carried out with the chassis shield in place. Dangerous high voltages are present in the final section when the transceiver is turned on. Use an insulated tool to make this adjustment.

6.10 VFO CALIBRATION

The VFO should be calibrated with the dial scale. However if for some reason the VFO is too far off calibration for proper adjustment, there is an internal VFO adjustment.

Remove the TS-520S's case and locate TC1 on the VFO section. Turn the FUNCTION switch to CAL-25 kHz and tune the main tuning knob so that the dial pointer points to an even 25 kHz frequency. Adjust TC1 to zero beat the calibrator frequency.

6.11 CRYSTAL CALIBRATOR ALIGNMENT

The crystal calibrator is factory aligned and should need no further adjustment. If it should drift out of calibration, find TC1 on the MARKER board. Tune the receiver to WWV at 15 MHz and turn on the calibrator by switching the FUNCTION switch to CAL-25 kHz. Adjust TC1 until the calibrator signal is zero beat with WWV.

6.12 REPLACING THE FUSE

When the fuse blows, there is some cause. Be sure to find the cause before attempting operation. Use a 6 amp fuse for 120V AC operation, and a 4 amp fuse for 220V AC operation. Under no circumstances use a higher amperage

fuse than those specified. Extensive damage can be caused. Also, the warranty can be voided if an improper fuse is used.

6.13 CLEANING

The knobs, front panel and cabinet of the TS-520S are likely to become soiled after extended use. The knobs should be removed from the transceiver and cleaned with a neutral soap and warm water. Use a neutral soap (not harsh chemicals) and a damp cloth to clean the cabinet and front panel.

Use an air blower or a soft brush to keep the interior clean and dust free.

6.14 REPLACEMENT PARTS

■ TUBES AND TRANSISTORS

Operation of the TS-520S without proper tuning, or operation of the transceiver with a high voltage in excess of 1000 volts, will significantly reduce the life of the final amplifier tubes. A bad tube or tubes should be replaced with S2001A (6146B) tubes. Matched tubes are not required, however neutralization is required with new tubes. The driver is a 12BY7A.

The transistors in the TS-520S can easily be damaged by being shorted or shocked by metallic tools. Be very careful during service operations, and when possible, use insulated tools.

■ SERVICE PARTS

Be sure to use replacement parts of equal or better ratings when servicing the transceiver.

When ordering replacement or spare parts for your equipment, be sure to specify the following information:

Model number and serial number of the equipment
— Schematic number of the part — and the board number on which the part is located.

Should it ever be necessary to return the equipment for repair be sure to pack it very carefully and include a full description of the problems involved.

SECTION 7. TROUBLESHOOTING

7.1 GENERAL INFORMATION

The problems described in this table are failures caused in

general by improper operation or connection of the transceiver, not by defective components. There is a separate service manual for repair of the TS-520S.

7.2 TRANSMITTER AND RECEIVER CIRCUITS

SYMPTOMS	CAUSE	REMEDY
Pilot lights do not light and there is no receiver noise when the POWER switch is turned on.	<ol style="list-style-type: none"> 1. Bad power cable or connections. 2. Blown power supply fuse. 3. Wrong polarity connection for DC operation. 	<ol style="list-style-type: none"> 1. Check cables and connections. 2. Replace the fuse. 3. Check for a negative ground power connection.
Frequency difference between transmit and receive. FMing on sideband operation.	<ol style="list-style-type: none"> 1. 9V DC supply not adjusted. 2. Short circuit in 9 volt power supply or line. 3. Improper battery voltage in mobile or portable operation. 	<ol style="list-style-type: none"> 1. See Section 6.6. (page 39) 2. Check the 9 volt supply. 3. Check battery or alternator voltage.
VFO (or FIX) indicator does not light.	<ol style="list-style-type: none"> 1. Rear panel VFO plug not inserted. 	<ol style="list-style-type: none"> 1. Insert the jumpered plug.
The relays operate with the stand-by switch in the REC position.	<ol style="list-style-type: none"> 1. Improper microphone connection. 	<ol style="list-style-type: none"> 1. Require the microphone connector.
Signal reports of off frequency operation even though the dial scale is calibrated.	<ol style="list-style-type: none"> 1. Calibrator requires alignment. 	<ol style="list-style-type: none"> 1. See Section 6.11. (page 40)

7.3 RECEIVER SECTION

SYMPTOMS	CAUSE	REMEDY
Accessory CW filter is installed but		

7.4 TRANSMITTER SECTION

SYMPTOMS	CAUSE	REMEDY
ALC meter deflects with no output (no plate current).	<ol style="list-style-type: none"><li data-bbox="574 312 927 363">1. No high voltage (+800V) on the final tubes.<li data-bbox="574 363 756 388">2. Bad final tubes.<li data-bbox="574 388 829 413">3. SG switch is turned off.	<ol style="list-style-type: none"><li data-bbox="1027 312 1328 338">1. Check the HV power supply.<li data-bbox="1027 363 1235 388">2. Replace the tubes.<li data-bbox="1027 388 1243 413">3. Slide the switch up.